

THE BRITISH STEAM
LOCOMOTIVE

1825 - 1925

AHRONS



THE LIBRARY OF
YORK
UNIVERSITY

From the
RALPH GREENHILL COLLECTION



Digitized by the Internet Archive
in 2014

<https://archive.org/details/britishsteamrail00ahro>



Photo. by Elliott & Fry

E. W. Alvord.

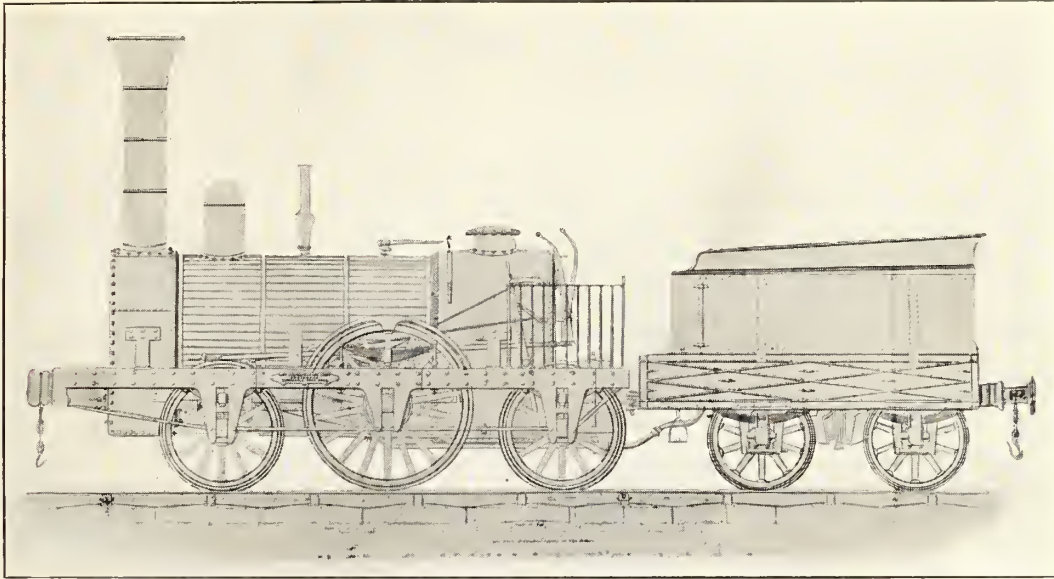

THE "HARVEY COMBE" FROM SIMM'S "PUBLIC WORKS OF GREAT BRITAIN"

"A CENTURY OF LOCOMOTIVE BUILDING BY ROBERT STEPHENSON AND CO.": SOME CORRECTIONS AND NOTES.

SIR,—Presuming on the welcome which you gave my book entitled "A Century of Locomotive Building by Robert Stephenson and Co." on its appearance, may I ask space for correction in regard to a notable locomotive, "Harvey Combe," which has been quoted for many years past as typical of Stephenson's standard patent engine as supplied to home and foreign railways, 1834-1840.

The makers' records state that the engine of this name, their No. 123, was intended for Belgium, but was supplied instead, on December 28th, 1835, to "Cubitt, of London."

Marshall, in his account of Robert Stephenson's patent locomotive, published in 1838, illustrates an engine which he states "was made for Messrs. Cubitt, the contractors for a part of the London and Birmingham Railway near Berkhamstead. . . . When the works were nearly completed . . . it was purchased by the railway company for the purpose of . . . repairing the road . . . in which work it is now employed." Marshall gives no name to the engine.

Whishaw, not long afterwards, in his "Railways of Great Britain," gives the Harvey Combe as on the books of the London and Birmingham Railway, where it was the more remarkable, indeed unique, as a Stephenson six-wheeled engine on a line equipped generally with four-wheeled engines by Bury.

Wood, in a "Report to the Directors of the Great Western Railway," December 10th, 1838, gives results of experiments on the Harvey Combe of the London and Birmingham Railway, to compare with contemporary experiments with the North Star of the Great Western Railway.

In the face of all this evidence the identification of the engine illustrated by Marshall, with the Harvey Combe, listed by Whishaw, seemed absolute, although the various descriptions do not agree in regard to the number of tubes and some minor dimensions. Such discrepancies are, however, so common in early records of locomotives, that they did not seem to outweigh the case for identity, and the drawings from Marshall were therefore reproduced on pages 318, 319, of Robert Stephenson and Co.'s Centenary Book as of the Harvey Combe.

But when engaged last year in collecting information for the reconstruction, at Swindon, of Stephenson's North Star, 1837, I was led to doubt whether the single-lever, four-excentric reversing gear fitted to this engine, and shown by Marshall for the supposed Harvey Combe, had been fitted so early as December, 1835, when that engine was completed. This improved gear does not appear much before 1837-8 on such original Stephenson drawings as still exist. It is then found on drawings for the North Star, La Victorieuse, and engines for the Grand Junction and other railways.

The makers' original drawing of the Harvey Combe does not exist, but I have found in Simm's "Public Works of Great Britain," 1838, Plate LXXVIII., a drawing definitely stated to be of the Harvey Combe, which confirms my doubts. The engine shown has a *four-handle loose-excentric* reversing gear. (See illustration.)

It appears therefore that either:—(a) Marshall did not illustrate the actual Harvey Combe, but a later and improved engine of the makers' standard type, omitting to notice the difference in the reversing gear; or (b) by 1838 the Harvey Combe had been refitted with the improved gear.

Until this point can be cleared up the name "Harvey Combe" applied to the engine shown by Marshall is at least doubtful. I am inclined now to think it is actually incorrect, and that the engines illustrated by Marshall and by Simms were never the same. It is remarkable that Bourne's sketch of a locomotive at work in Berkhamstead Cutting—page 326, "A Century of Locomotive Building"—shows the dome behind the chimney as Simms does. Marshall shows it on the fire-box. Bourne was an accurate draughtsman, and his evidence helps to point to two distinct engines.

May I add in regard to other special engines and types described in "A Century of Locomotive Building," that subsequent discoveries have generally confirmed or amplified the conclusions arrived at. M. Ferdinand Achard has found valuable information on the first locomotives sent to France, and on those of the Stockton and Darlington Railway—to which he has already alluded in a letter to THE ENGINEER—and an early woodcut has been found showing one of the first four engines of that railway as at work in 1829, being the earliest yet known.*

A number of original letters from Robert Stephenson give important information on the activities and interests of himself and his father, and prove that the piston valves shown on page 285 of "A Century of Locomotive Building" were actually fitted to one of the "Atlas" type of the Liverpool and Manchester Railway. It is shown too that Robert Stephenson had at the same time a design for a balanced slide-valve exhausting through the back.

On page 320 a correction is required in reference to Stephenson's locomotives in Belgium—Albert Simons should read Pierre Simons.

On the same page a doubt must be expressed as to the wheel arrangement of L'Eléphant, given, on a Belgian authority, as of the 2-4-0 type. It was more likely of the 0-4-2 type, as on page 315. The 2-4-0 type, page 324, was probably not adopted till after the date given for the construction of L'Eléphant.

Bath, September 22nd.

J. G. H. WARREN.

* This woodcut is reproduced with notes in the current issue of your contemporary, *The Locomotive*.



THE BRITISH STEAM RAILWAY LOCOMOTIVE

1825 - 1925

By

The late E. L. AHRONS, M.I. Mech. E., M.I. Loco. E.

1927:

THE LOCOMOTIVE PUBLISHING COMPANY LIMITED

3, AMEN CORNER, LONDON, E.C.4

SPON & CHAMBERLAIN

123, LIBERTY STREET, NEW YORK, U.S.A.

Printed by
RICHARD TILLING
106, Great Dover Street
London, S.E. 1

Foreword

Of all those who worship at the shrine of the steam locomotive there has never been one more devout and more learned than the late E. L. Ahrons. He not only showed for the history of the locomotive that enthusiasm which characterises your true historian, but he brought to it, also, a degree of technical knowledge higher than is to be found in many of those who have surrendered themselves to the fascination of that subject. He received his early training as an engineer at Swindon, and although his subsequent career was spent mainly in other fields of engineering, his early love for locomotives never left him. He maintained, moreover, to the last a close touch with technical progress, and his book "The Development of British Locomotive Design," issued in several editions by the Locomotive Publishing Company, is still a familiar work of reference amongst locomotive men.

His greatest work was undoubtedly the series of articles which he was commissioned to write for THE ENGINEER in celebration of the Railway Centenary. No one who was not in touch with him, as the present writer was, during the preparation of those articles can have any conception of the work he put into them, and the extraordinary care he took to verify every point. It did not matter how small the hint or how trivial the enquiry; if it could help at all he pursued it to the last, and he wrote a veritable volume of letters as well as the series itself. It must be freely admitted that the exigencies of the Press hampered him a little. To begin with, when he and I together schemed out the series it became evident that unless some limit was put to it, it would extend beyond reasonable bounds. We had, therefore, to decide to omit all the early history—that is, the history prior to 1825—and to condense strictly all history more recent than 1900. Moreover, when the articles came in they were crowded with illustrations, and I found it imperative to make certain omissions. I should like to say here in memory of an old friend that never, in the course of the whole transaction, did we have a difficult word together. He knew, I hope, that I regretted omissions as much as he did, but he invariably cheerfully acquiesced, and always indicated what could be left out with least injury to the history. Never—and I think Mr. Bell, of the Locomotive Publishing Company, will agree with me in this—was there an author who was more ready to see the Editor's point of view.

This republication of the series in book form is a very notable event. The volume not only brings all the articles together in a convenient form, but a considerable number of illustrations which had to be left out of the original have been added, so that the volume is actually more complete than the articles. Moreover, it has been possible to make certain emendations and to take advantage of the correspondence which took place during the publication in THE ENGINEER. Take it for all in all, it may now be said without the slightest fear of contradiction that it is the most complete, the most accurate, the most detailed history of the British steam locomotive between 1825 and 1925 which has ever been written. It possesses, moreover, the advantage that since Ahrons, owing to his early training, could appreciate technical points he was able to convey to the readers a good idea of the reasons which prompted successive changes in the design of engines. The book is, therefore, not a mere record of such changes, but, in many cases, presents the arguments which led to the alterations.

There will be found, throughout the volume, references to articles by the same author which were published in THE ENGINEER under the general title of "Short Histories of Famous Firms." Although some articles in that series came from other pens, most of them were written by Ahrons and dealt with firms which had been wholly or partly engaged in locomotive building. Those articles have not been collected in book form, but it is perhaps fitting to say here that they form a valuable corollary to the present volume.

LOUGHNAN PENDRED.

April, 1927.

Editorial Note

The late Ernest Leopold Ahrons was born on February 12th, 1866, at Bradford, and was educated at the Bradford Grammar School and Yorkshire College, Leeds. As a student at the latter he obtained one out of three advanced scholarships in mathematics and physics, and was awarded first prize in engineering construction and mechanism and machinery. Leaving college in 1885, Ahrons went as a pupil under Mr. W. Dean to Swindon Locomotive Works, Great Western Railway, until 1888, and for two years after was employed in the Drawing Office and as an inspector of materials. In 1890 he became Chief Draughtsman to Messrs. Fleming, Macfarlane & Co., of Middleton, and soon afterwards obtained a position on the drawing office staff of Messrs. Beyer, Peacock & Co., Ltd. He was appointed in 1892 to the position of Engineer and Manager of the Government Workshops attached to the Ecole Khédiviale d'Arts et Métiers, at Boulac, Cairo. Owing to ill health, he resigned this appointment in 1898, and returned to England. In the same year he became engineer-in-charge of the general department of Messrs. Henry Simon, Ltd., of Manchester. Between the years 1902 and 1917 he held various positions in engineering industry, and during the Great War acted as a Trade Officer at the Department of Overseas Trade (Development and Intelligence). He resigned from the Government service in 1919, and until his death devoted himself entirely to literary work. His first contribution to the press appears to have been a note on "North Western Engines," which appeared in THE ENGLISH MECHANIC of May 20th, 1881, over the nom de plume "Meteor," which he used with all his earlier writings. From this time onwards he was a frequent contributor to the engineering and mechanical journals of notes, letters and short articles, and in 1903 commenced in THE LOCOMOTIVE MAGAZINE a series of articles on the Egyptian Government Railways and locomotives. Amongst the books he wrote mention should be made of his "Development of British Locomotive Design," "Repairing of Locomotives," and "Lubrication of Locomotives," as well as primers on the "Steam Locomotive," "Steam Locomotive Construction and Maintenance," and "Steam Engine Valves and Valve Gears." To THE ENGINEER he contributed an admirable series of descriptive "Short Histories of Famous Firms," in which he dealt with the origin of many British companies which built locomotives during the last century. His practical acquaintance with locomotive design and operation gained

by his experience at Swindon gave him an intimate knowledge of the principles of locomotive engineering, which, combined with a complete knowledge of locomotive history, fitted him to undertake the exhaustive series of articles for THE ENGINEER in 1925 on the "British Steam Railway Locomotive from 1825 to 1924," forming the most comprehensive history of the subject which has ever been written.

Mr. Ahrons had intended to republish these articles in book form and to include the latest developments in locomotive engineering to the end of 1925, but his untimely death on March 30th, 1926, prevented this.

The work of arranging for publication in the present form had therefore to be carried out by others, and the responsibility for this rests mainly on his personal friends, Messrs. A. C. W. Lowe, J. G. H. Warren, and W. J. Bell, who have spared no pains to complete the work in a manner which it is believed would have been acceptable to the author.

Contents

CHAPTER		PAGE
I	1825-27 First Stockton and Darlington Rly. locomotives—Wilson's four-cylinder locomotive—Stephenson's "Experiment"—Hackworth's engine "Royal George"—The blast pipe.	I-8
II	1828-31 Engines with inclined cylinders—"The Lancashire Witch"—Stephenson's six-coupled engine "Rocket," S. & D. Rly.—Stephenson's locomotives for France, 1828-29—Hackworth's six-coupled engine "Victory"—Later engines of the Killingworth and Wylam types, 1829 to 1831—Liverpool and Manchester Rly.; Rainhill trials, "The Rocket"—T. Hackworth's "Sanspareil"—Braithwaite's and Ericsson's "Novelty"—A comparison between "The Rocket" and the "Sanspareil"—Later engines of the "Rocket" type—Braithwaite and Ericsson's "William the Fourth"—Canterbury and Whitstable Rly. "Invicta."	9-17
III	1830-37 Three Schools of Locomotive Engineers—Bury's 0-4-0 engine "Liverpool"—Stephenson's 2-2-0 engine "Planet"—Hackworth's "Globe"—Stephenson's 0-4-0 goods engine, 1831—Rothwell and Hicks's 2-2-0 engine, 1832—Stephenson's six-wheeled engines—Goods engines, 0-4-2 and 0-6-0 type—Bogie locomotives—Hackworth's engines with vertical cylinders—Forrester's engines with outside horizontal cylinders—Hawthorn's "Comet" and "Planet" type locomotives—Short stroke locomotives.	18-32
IV	1837-41 Bury's bar-framed locomotives—The 2-2-2 passenger engine—Boilers—Fire-box roof stays—Boiler fittings—Frames—Motion details—Miscellaneous details—Coupled engines with inside cylinders—Outside cylinder engines—Norris American built engines—John Gray's express engines with mixed frames—Tank engines—Broad gauge engines, Great Western Rly., 1837 to 1842—Early engines, 1837-38—Stephenson's "Star" class—D. Gooch's engines—Outside sandwich frames on the G.W.R.	33-47
V	1841-45 Stockton and Darlington Rly. and later Hackworth engines—Bury type engines—Standard engines with inside cylinders—The "Crewe" type of outside cylinder locomotive—Stephenson's long boiler engines—Stockton and Darlington Rly. long boiler passenger engines—Long boiler goods engines—The 0-6-0 engine with outside cylinders—Banking engines—Balanced locomotives—Bodmer's locomotives—Constructional details.	48-64
VI	LOCOMOTIVE PERFORMANCES TO END OF 1845 Fuel consumption—speeds.	65-67
VII	1846-49 Gooch's Great Western Rly. broad gauge engines, 1846-49—Outside cylinder Cramp-ton locomotives—Other express engines of special types—Three-cylinder engine—"Standard" passenger engines, inside cylinders—Outside cylinders—Four wheels coupled passenger engines—Goods locomotives—Goods engines with outside cylinders—Scottish types—Passenger tank engines—Steam motor coaches.	68-85
VIII	1849-55 Intermediate driving shaft locomotives—Uniflow locomotive—Compound locomotives—Passenger tank locomotives with single driving wheels—Express engines—Mixed traffic 0-4-2 engines—Six wheels coupled goods engines—Tank engines with coupled wheels—Engine brakes—Broad gauge tank locomotives—Bristol and Exeter Rly. broad gauge double bogie express tank engines—Miscellaneous details of construction, 1846 to 1855.	86-112
IX	1855-59 2-2-2 express engines, inside cylinders—2-2-2 engines, outside cylinders—Four wheels coupled express engines—Other four wheels coupled engines—Four-coupled mineral engines—Bogies—Tank engines with leading bogies—Other four coupled tank engines—Passenger tank engines with six wheels coupled—0-6-0 goods engines—Neilson's single-cylinder locomotive—Details.	113-127
X	LOCOMOTIVE PERFORMANCES, 1845-59 G.W.R. broad and standard gauge engines—Coal burning—Locomotive fuel, 1825 to 1850—Hall's system of smoke consuming—Dewrance's double fire-box—Air inducing steam jets—McConnell's boiler—Beattie's boiler—Cudworth's fire-box—Other coal burning systems—Coal consumption and evaporation—Welsh coal burning in locomotives.	128-136
XI	BRITISH LOCOMOTIVES FOR ABROAD European Railways—Twin tank engines by R. Stephenson & Co. for the Giovi incline, Italy—2-4-2 passenger tender engine—Bogie locomotives for abroad—Locomotives for Egypt—Locomotives for British Colonies—Locomotives for India.	137-142

CONTENTS—*continued.*

CHAPTER		PAGE
XII	1860-65 2-2-2 express engines, outside cylinders—2-2-2 express engines with inside cylinders— 2-4-0 express engines—Passenger engines with leading bogies—Passenger tank engines—Four wheels coupled goods engines—Six coupled goods engines—Tank engines for steep gradients—Eight wheels coupled tank engines—Sturrock's steam tenders—Frames—Radial and other axle-boxes with lateral movement—Bogies.	143-166
XIII	1866-69 Express engines with "single" driving wheels—Four coupled engines—Four coupled mixed traffic engines—Four coupled passenger tank engines—Six wheels coupled tender engines—six wheels coupled tank engines—Six coupled passenger tank engines —Locomotives for Ireland and overseas, 1860-69—India—Other locomotives for overseas.	167-184
XIV	1870-75 Express engines with "single" driving wheels—Single <i>v.</i> coupled engines—Express engines, 2-4-0 type—4-4-0 express engines—Passenger tank engines with six wheels coupled—Goods engines, 0-6-0 type—Main line goods tank engines—Details—Counter pressure braking	185-209
XV	1876-81 2-2-2 express engines—4-2-2 express engines—2-4-0 express engines—Leading bogies —4-4-0 engines with inside cylinders—4-4-0 engines with outside cylinders—Engines of the 0-4-2 type—Main line tank engines—Four coupled tank engines for local traffic —Six coupled passenger tank engines—Goods engines, 0-6-0 type—Goods engines, 2-6-0 type—Single Fairlie passenger tank engine—Small shunting engine.	210-227
XVI	TRAIN RESISTANCES AND LOCOMOTIVE PERFORMANCES, 1855-79 Great Western Rly.—Great Eastern Rly.—South Eastern Rly.—Great Northern Rly. —Early records—Speeds at the Newark brake trials—London and North Western Rly., 1876-79—South Eastern Rly.—Great Northern Rly., 1875-79—Midland Rly., 1874-79.	228-236
XVII	ENGINES FOR IRELAND AND OVERSEAS, 1870-79 Ireland—Continental European locomotives—Other engines for overseas—Metre gauge locomotives—Indian Railways—Hall's cranks.	237-242
XVIII	COMPOUND LOCOMOTIVES, 1882-89 Webb's first compound locomotives—The genesis of the three-cylinder compound—The "Experiment" of 1882—The "Compound" class of 1883-84—"Dreadnought" class— "Teutonic" class—Advantages of Webb's three-cylinder system—Defects of Webb's three-cylinder compound system—Performances of Webb's three-cylinder compound— Compound tank engines—Two-cylinder compound express engines—Compound goods engines with two cylinders—Four-cylinder tandem compound locomotives.	243-262
XIX	1882-89 NON-COMPOUND LOCOMOTIVES 2-2-2 engines—4-2-2 engines—2-4-0 express engines—4-4-0 engines—Engines of the 0-4-2 type—Eight wheeled tank engines—Ten wheeled tank engines—Goods engines, 0-6-0 type—Eight coupled tender engines—Six coupled tank engines—Details in con- struction—Bogies—Sanding apparatus—Water pick-up apparatus—Cabs.	263-288
XX	1890-1900 Two cylinder compound engines—Compound locomotives, Webb's three-cylinder system—Four cylinder compound engines, Webb's system—Three-cylinder compound engine, Beyer, Peacock & Co.—Three-cylinder compound engine, W. M. Smith's system—Triple expansion locomotive—Two-cylinder high pressure engines—2-2-2 loco- motives—4-2-2 locomotives—2-4-0 engines—4-4-0 engines—Four-cylinder non-com- pound engines—4-4-2 express engines—4-6-0 express engines—Passenger tank engines —Two-cylinder compound passenger tank engines—2-6-0 goods engines—4-6-0 goods engines—0-8-0 mineral engines—2-6-0 tank engines—Eight coupled tank engines— Details—Oil fuel—Locomotives speeds and performances, 1880 to 1900.	289-312
XXI	ARTICULATED, STEEP GRADIENT AND MISCELLANEOUS LOCOMOTIVES Twin locomotives—Fairlie double locomotives—Kitson-Meyer locomotives—Mallet locomotives—The Garratt engine—Fell engines for steep gradients—Rack-rail loco- motives—Other engines built for overseas.	313-321
XXII	1901-14 Compound locomotives with three cylinders—Compound engines with four cylinders— Compound locomotives in India—4-4-0 non-compound engines—4-4-2 locomotives with two cylinders—4-6-0 express engines, two-cylinder type—Locomotives with four cylinders —4-6-2 express engine—Three-cylinder non-compound express engines—Three-cylinder tank engines—Passenger tank engines, two-cylinder type—Goods tender engines, 0-6-0 type—2-6-0 goods engines—Locomotive with multiple single-acting cylinders—4-6-0 express goods engines—eight wheels coupled engines—eight wheels coupled side tank engines—Steam motor coach locomotives—Boilers—Superheaters—Feed-water heating.	322-354
XXIII	1914-25 Express passenger engines—Mixed traffic, goods and mineral engines—Tank engines —Details—Boilers—Bogies and pony trucks—Booster—Motion, valves and valve gear —Lubrication—Locomotive tenders—Conclusion.	355-372
	INDEX	373-391

The British Steam Railway Locomotive

from 1825 to 1925

By the late E. L. AHRONS, M. I. Mech. E.

Chapter I—1825-27

WHEN the Stockton and Darlington—the first public railway to use steam power—was opened, there was but one locomotive, the celebrated “Locomotion No. 1,” which had been delivered in September, 1825, by R. Stephenson and Co., from their Forth-street Works, New-

described as the Stephenson Killingworth type of engine with certain modifications. The wrought iron boiler, 10ft. 4in. long by 4ft. diameter and of $\frac{1}{2}$ in. plates, was of the single through flue type, the flue being 2ft. diameter. At the front the flue was continued upwards as a chimney. There

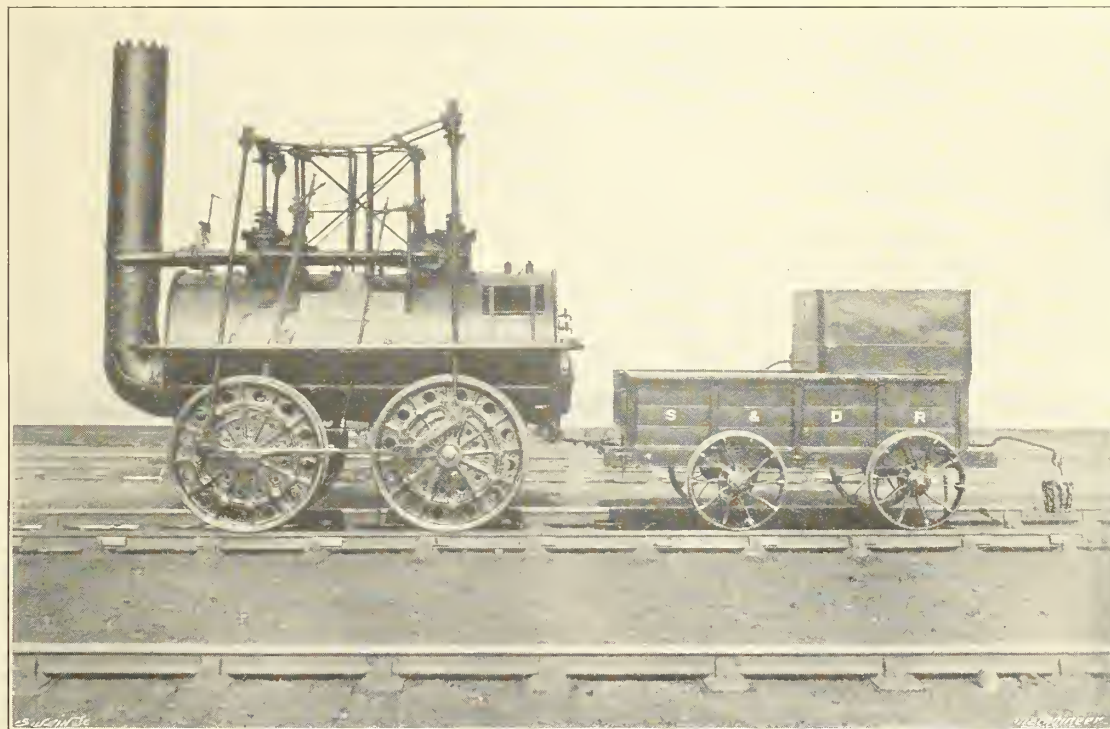

FIG. 1.—“LOCOMOTION NO. 1”—STOCKTON AND DARLINGTON RAILWAY, 1825.

castle. The evening before the public opening of the line on September 27th, it made a trial run from Shildon to Darlington with a party of the “Committee,” as the directors were then termed. They were accompanied by George Stephenson, whose elder brother James drove the engine.

“Locomotion,” as it now exists after sundry alterations, is shown by Fig. 1, and may be

were two vertical cylinders, each $9\frac{1}{2}$ in. by 24in., the lower portions of which were placed inside the boiler. Each cylinder was placed vertically above the centre of the wheel, to which its connecting-rods were attached. The piston-rods issued from the tops of the cylinders, and the two cross-heads, which were guided by half-beam parallel motions, extended across the top of the boiler to form the

connections to four long connecting-rods, two on each side of the engine. The late Joseph Tomlinson¹ stated that "the pistons were packed with a spun yarn gasket, plaited square, which was tightened by a piece of wood and a hammer." Warren² adds that the drive from the cylinders and the half beam parallel motion "appear to be a retrogression from the more simple construction of the Killingworth and Hetton engines." In the engine as now preserved at Darlington there is a single eccentric for both fore and back gear of both slide valves. This eccentric had a notch plate or reversing disc at the side, and was driven

rear cylinder.—Fig. 2³ Connected to the valve spindles were two starting handles, by means of which the driver could disengage the eccentric rods from the valve-rocking levers, and move the latter by hand to start the engine. The disengagement was effected by means of a sliding catch on the end of each eccentric rod, which was released when the engine had to be reversed. When the engine was in motion the catch was engaged.

The original valve gear of some of the first four Stockton and Darlington locomotives was slightly different.⁴

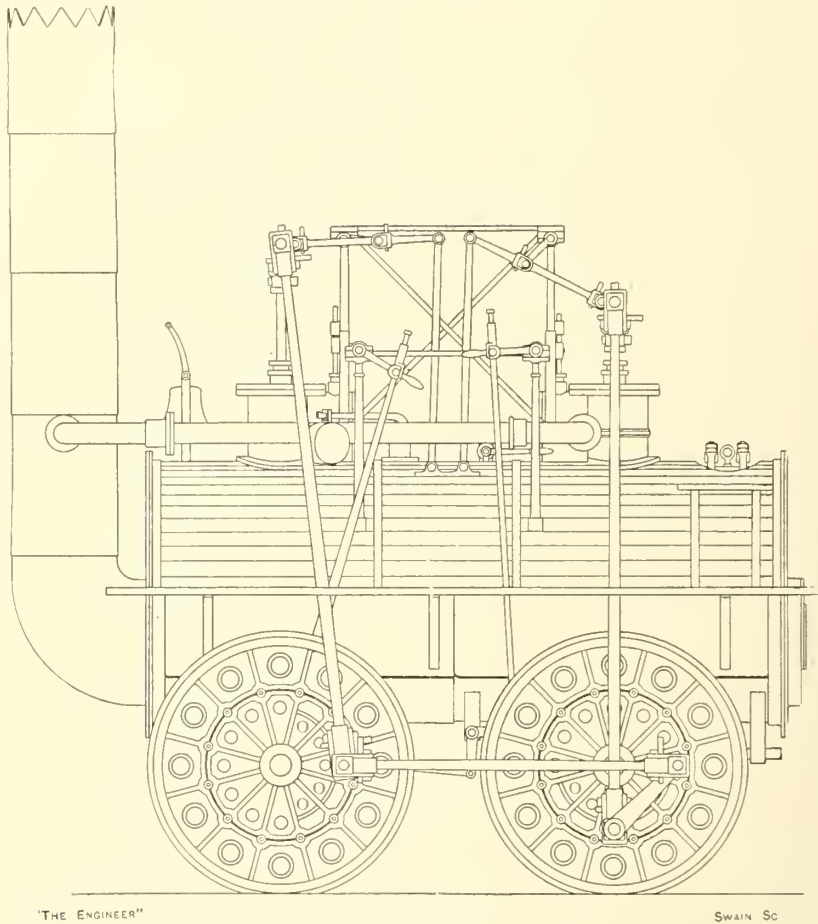

FIG. 2—"LOCOMOTION NO. 1"—STOCKTON AND DARLINGTON RAILWAY, 1825.

by a lug on the wheel. The main eccentric rod was carried upwards in a vertical direction to drive the valve of the front cylinder, and a second rod from the same eccentric passed horizontally to a bell crank lever for driving the valve of the

¹ Presidential address, Inst. Mech. Engrs., 1890. Joseph Tomlinson was born 1823, died 1894.

² "A Century of Locomotive Building by Robert Stephenson and Co., 1823-1923," by J. G. H. Warren. Further references to this book will, to save space, be quoted under the name "Warren."

³ Taken from THE ENGINEER of July 16th, 1920: Dunlop on "The Development of Locomotive Valve Gears." For a more detailed drawing see THE LOCOMOTIVE, p. 14, Feb. 14th, 1925.

The four wheels were 4ft. diameter, and the axles revolved in cast iron plummer blocks, but in the original design one axle worked inside an iron tube, to the middle of which a bracket supporting the boiler was fixed with the probable intention of providing a three-point support for the engine. There were no bearing springs, though Nicholas Wood at about this time applied springs to the Killingworth engines.

⁴ For valve gear, see Warren, drawing, page 114, and description, page 119, from a report of two Prussian engineers on the Stockton and Darlington Railway engines. See also THE LOCOMOTIVE, page 302, Sept. 15th, 1926.

One of the interesting features was the arrangement of cranks and coupling-rods. The cranks of each pair of wheels being worked from one cylinder, were necessarily parallel, but were placed at 90 deg. with those of the other pair of wheels, the front cranks leading. Direct outside coupling rods were used, the pins for the back end being fixed in return cranks. The idea of these outside coupling rods has been credited by his son to Timothy Hackworth, who, during 1824, was temporarily employed by R. Stephenson and Co. at Forth-street Works, but unfortunately there is no documentary proof to show who originated them. D. K. Clark ascribed them to G. Stephenson, and certainly the latter, in conjunction with Ralph Dodds, had used an inside coupling rod at Killingworth in 1815. The coupling rod pins, as shown in the earliest original drawing⁵ in the possession of R. Stephenson and Co., were spherical. Even in these early days the lateral displacement of one coupled axle with respect to the other was foreseen and provided for. Spherical pins, of which we shall meet with several examples, are rarely used now in this country, but they are common on the European Continent, more especially in the front coupled wheels of engines provided with combined bogies of the Krauss-Helmholtz type. The framing was of cast iron.

The boiler carried 50 lb. pressure and had a heating surface of about 60 square feet. The figures in regard to pressure are somewhat contradictory. In Newton's "London Journal," Vol. 10, 1825, it is stated that "the steam pressure was 30 lb., and the safety valve was loaded to 50 lb. per sq. in." The Prussian engineers, who visited the railway in 1827, gave the pressure as 52 lb. Joseph Tomlinson stated that when first put to work it would not steam, and that the fire tube had to be replaced by a return flue. The weight in working order of the existing engine was given as about 6½ tons, on a former description plate on the engine, but this appears to be incorrect. Mr. A. C. Stamer, Chief Assistant Mechanical Engineer, London and North-Eastern Railway, has recently weighed the engine and found the figures to be 8 tons 8 cwt. full and 6 tons 16 cwt. light. The tender ran on four wheels, the frame being of wood with a sheet iron tank. Tomlinson refers to two tenders, which were usual with many of the early Stockton and Darlington engines, but the second tender must have been a subsequent addition when the boiler was altered to the return flue type.

The cast iron wheels shown in the illustration were of Hackworth design, and added at a later date.

Three other engines, 2 "Hope," 3 "Black Diamond," and 4 "Diligence," were supplied by Messrs. Stephenson to the Stockton and Darlington Railway between November, 1825, and May, 1826. "Locomotion" had an adventurous career. The boiler exploded in July, 1828, after which the locomotive was rebuilt by T. Hackworth

at the company's workshops at Shildon. He gave it a new boiler, with a single flue and two return tubes, but subsequently a third boiler with single flue of the original design was supplied, and in this form the engine finished its working career. It continued in service on the railway until 1841, but appears to have been called upon to officiate on festive occasions, such as the opening of the Middlesbrough and Redcar line in 1846, when it headed the procession. For some years afterwards it was used by Messrs. Pease and Partners as a pumping engine, and in 1857 was placed on a pedestal near North-road Station, Darlington. On the occasion of the Jubilee of the Stockton and Darlington Railway in September, 1875, it was again in steam. In 1876 it visited the Philadelphia Exhibition, and in 1881 appeared in the procession of locomotives at the Stephenson Centenary. It was shown at the Liverpool Exhibition, 1886; Newcastle Jubilee Exhibition, 1887; and the Paris Exhibition of 1889, and in 1892 was placed on a pedestal in Bank Top Station, Darlington. It remained there until 1924, when it was shown at the British Empire Exhibition at Wembley. On July 2nd, 1925, it took part in the Centenary celebrations, when it travelled from Stockton to Darlington with a train of wagons. It has now been replaced on its pedestal at Darlington Station.

It may be added here that the plate affixed to the engine gives the boiler pressure as 25 lb. per square inch, which may have been the load on the safety valves in its later days. The records also show that the cylinders had been enlarged to 10in. diameter.

Wilson's Four-cylinder Locomotive, Stockton and Darlington Railway.—A fifth locomotive on the Stockton and Darlington Railway was built by Robert Wilson of Gateshead. Colburn ("Locomotive Engineering," page 21) described it as an engine with four cylinders, two to each pair of wheels, and adds that it appears to have been the first in which each pair of wheels was worked by two pistons acting upon cranks at right angles to each other. But the putting into shape of an excellent idea seems to have been faulty. W. W. Tomlinson, in his "History of the North-Eastern Railway," stated that though the engine "worked unsatisfactorily when on trial, it had been purchased for a small sum for the sake of its boiler and then laid aside." Nothing more seems to be known of this engine, of which the boiler was afterwards utilised for Hackworth's "Royal George" of 1827.⁶

⁶ In a letter to THE ENGINEER dated Feb. 15th, 1925, Mons. F. Achard, of Paris, states that in course of researches made partly in connection with Mr. Augustin Seguin, he has made some discoveries in connection with the "Chittaprat"—four-cylinder locomotive by Wilson for the Stockton and Darlington Railway—and with the Stephenson locomotives sent to the St. Etienne-Lyon Railway about 1828, including sketches and drawings of both. He intends publishing these, and points out that these evidences modify to a certain extent the statements published particularly in respect to the "Chittaprat." But hitherto, Colburn's statement, quoted above, has been accepted, except by Warren, p. 117.

⁵ Warren, page 114.

Stephenson's "Experiment," Stockton and Darlington Railway.—The Stockton and Darlington Railway engine No. 6, "Experiment," was stated to have been delivered by R. Stephenson and Co. in March, 1827. This is the date given by Tomlinson in his "History of the North-Eastern Railway," but Messrs. Stephenson have no record of the delivery, and Hackworth's notebook records the date as January, 1828.⁷ But it was certainly built early in 1827, as it was then seen and fully described by two Prussian engineers who visited Stephenson's works.⁸ It originally ran on four wheels, but in 1828 was altered to a six wheels coupled engine.

The main features of this remarkable locomotive were as follows:—It was the first to have two horizontal cylinders; they were placed within the boiler with back covers almost flush with the fire end. The piston-rods were attached to swinging lever arms, which caused a transverse rocking shaft above them to oscillate. Other levers on this shaft were coupled to the connecting-rods, which drove the crank pins on the leading wheels.

The boiler had a single flue and the fire-grate consisted of water tubes, which could be cleaned through a cast iron box at the back. At the front or chimney end they opened into a drum placed inside the flue, which extended forward to the chimney. The drum was in communication with the boiler by means of a rectangular opening through the upper part of the combustion chamber. The boiler was also connected with the cast iron box by two pipes. It resulted that the portion of the flue through which the hot gases passed formed an annular ring round the drum, and water circulated through the boiler, drum, and grate. The exhaust steam passed through the boiler towards the chimney, but before being discharged into the atmosphere, part of it passed through a feed-water heating tank. This is the earliest known example of a locomotive with such an appliance, though it is within the bounds of possibility that Trevithick's Pen-y-darran locomotive may have had one on the principle shown in Farcy's drawing⁹ of his stationary engines, which appear to have been generally provided with a cylindrical heating vessel through which the exhaust pipe passed on its way to the chimney.

In 1830 the "Experiment" was entirely remodelled by Timothy Hackworth, with return flue, and the engine was then fashioned after the construction of the "Royal George."¹⁰

The burden of the locomotive working of the Stockton and Darlington Railway between 1825 and 1827 had to be borne by the four engines of

the "Locomotion" class, and disquieting reports with regard to the success of this new form of motive power began to circulate. The directors were stated to have seriously considered the question of abandoning locomotives altogether. Had this occurred, the success of railway transport would have been seriously jeopardised, and the clock of progress put back many years. The true circumstances, whatever their nature, have formed the subject of acrimonious controversy in the past. To form a sound judgment those interested should consult "The North-Eastern Railway," by W. W. Tomlinson (pp. 140-142), and "A Century of Locomotive Building by Robert Stephenson and Co.," by J. G. H. Warren, on the one side, and "Timothy Hackworth and the Locomotive," by R. Young, on the other. In all of these many original documents are quoted.

There are, however, certain points which occur to the unprejudiced reader of locomotive history. The four early Stockton and Darlington Railway engines by Stephenson were necessarily constructed without previous experience of the arduous requirements of a public railway much longer than the short colliery lines hitherto in use, and it was to be expected that defects would be found in complicated locomotives working under new and extremely defective traffic conditions. Moreover, the engine drivers were rough and not specially trained men, such as those with whom we are now familiar, and they could not be expected to handle their engines with the necessary care. The locomotive builders would be informed of defects one by one as they were discovered, and then only after the engines had left their hands, too late to make the necessary alterations and improvements. The responsibility—no light one—of carrying on the traffic lay with Timothy Hackworth, who had been appointed locomotive superintendent of the railway before it was opened for traffic. It has been said that the modern locomotive superintendent "has to sleep with his boilers." Hackworth alone, and without the skilled assistance given to his modern successor, had to "sleep" with the whole of his engines, and his task was no sinecure. He was the man, a part of whose duties consisted in investigating reports and causes of failures, and he, and not Robert Stephenson and Co., had the first opportunity of finding the remedies. It was the keen observation which he brought to bear upon the working of the details of the locomotives and engines under his charge which made Hackworth the excellent practical locomotive superintendent which he undoubtedly was. Whilst giving Hackworth all the credit justly due to him, there is not the least justification for belittling the work of Robert Stephenson and Co. because they did not at once turn out a perfect locomotive. That improvements were soon found to be necessary is obvious, but there is no evidence for the statement which has been made that but for unfair influences locomotives "would have been aban-

⁷ "Timothy Hackworth and the Locomotive," by Robert Young, in which some particulars of the engine may be found. The general description of the engine given above has been abridged from Warren, pages 120-125, in which a full account and sketches by J. U. Rastrick are given.

⁸ Warren, page 120.

⁹ Rees' "Cyclopaedia," 1819. Also Hebert's "Engineer's and Mechanic's Encyclopaedia," 1849.

¹⁰ "Timothy Hackworth and the Locomotive," page 165.

done long before an experimental period of eighteen months had been allowed."

The heating surface, about 60 square feet only, of the single-flue boilers was too small, though the whole of it was furnace and "combustion chamber" surface, which gave a high evaporation per square foot. The boiler had the advantage of cheapness in first cost, and, unlike the engines with return flue boilers, two tenders were not necessary. But the type of boiler was not economical; though whether the saving of fuel at that time was considered of much importance is doubtful.

Hackworth's Stockton and Darlington Railway Engine "Royal George."—In September, 1827, Timothy Hackworth constructed at the railway works at Shildon his new engine "Royal George." The boiler was 13ft. long by 4ft. 4in. diameter,

drive was a great improvement upon Trevithick's indirect arrangement, as used on the small "Catch-me-who-can" locomotive, in which a single cylinder only was used, though the connecting-rods were coupled to pins in the driving wheels.¹¹ The "Royal George" had no slide bars, the pistons being guided by parallel motion, which worked a valve shaft on which two loose eccentrics were fixed. From these, both slide valves and reversing were operated. At a later date the valve gear was altered and the eccentrics placed on the driving axle. The three axles were coupled to distribute the weight on the rails more evenly, and the engine was the first to have six wheels¹² coupled by means of the usual form of outside coupling rods. The wheels were 4ft. diameter, of cast iron, and of the peculiar pattern long afterwards a feature of

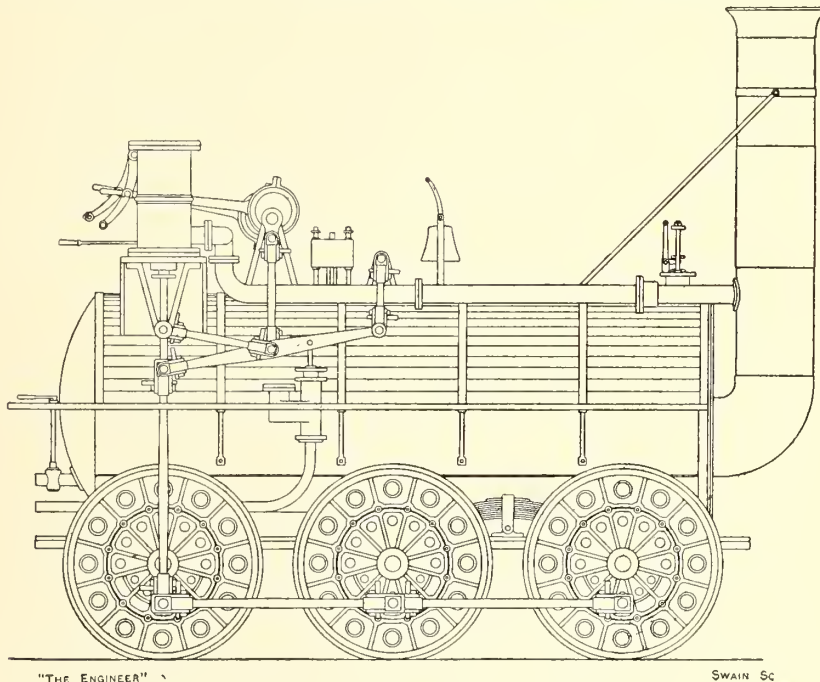

FIG. 3—THE "ROYAL GEORGE"—STOCKTON AND DARLINGTON RAILWAY, 1827

and contained an internal U-shaped return flue 2ft. 2in. diameter at the furnace or front end, reduced to 1ft. 6in. diameter at the same end, where it terminated at the chimney. The greatly increased heating surface, due partly to the return flue and partly to the larger boiler, was 141 square feet, or more than twice that of the "Locomotion." The pressure was 52 lb. per square inch, at which the spring-loaded safety valve was set, though the lever valve began to blow off at 48 lb. The return flue type of boiler was not new, and had been used in Trevithick's engines. The vertical cylinders, 11in. by 20in., were placed one on each side at the back of the engine, and the pistons working downwards were connected directly to the trailing pair of wheels. This form of direct

Hackworth's engines. They were made in two parts, owing to the lack of lathes at Shildon large enough to turn up the rims when fixed on the axles.¹³ The outer rim was trued to the machined centre, and fixed tightly by wood plugs and iron wedges. The large number of holes were made to ensure sound castings and reduce the weight. The front pairs of wheels were connected on each side

¹¹ A similar arrangement to this was applied by Dodds and Stephenson in 1815.

¹² Dodd's and Stephenson's six-wheeled engine of 1815 had two axles coupled by inside coupling rods, but the middle and third axles were coupled by chains. See Warren, pages 22 to 24.

¹³ "Timothy Hackworth and the Locomotive," page 158.

by a single longitudinal laminated spring,¹⁴ as shown in Fig. 3, but the trailing wheels, owing to their direct connection with the vertically moving pistons, were springless.

A portion of the exhaust steam was turned into a cistern for heating the feed water, but this arrangement had previously been used in Stephenson's "Experiment" locomotive. In the "Royal George," the cistern was connected to the tender tank, and the driver could regulate both exhaust and water supply. Novel features included a short-stroke feed pump worked by an eccentric, and self-lubricating bearings. The safety valves were of the direct spring-loaded form, but the first application of these to locomotives was made before 1815 by Fenton, Murray and Wood to Blenkinsop's rack rail engines at Leeds.¹⁵ In the latter case, spiral springs appear to have been used, but Hackworth employed elliptical leaf springs. The latter design of spring-loaded valve was new, and for about twenty-five years was generally used on locomotives. The "Royal George" was the first engine to be provided with a contracted orifice to the blast pipe.

The engine was undoubtedly a successful locomotive, and the most powerful constructed up to that time. Hackworth had put to good account the experience he had gained in his daily observation of the working of the engines under his charge.

The Blast Pipe.—The subject of the blast pipe, the invention of which is still debated, cannot be passed over in any historical account of the locomotive. In the following analysis, the writer has attempted impartially to set forth the salient points.

In February, 1804, Richard Trevithick's rail locomotive was tried at Pen-y-darran, near Merthyr. Very little that is authentic is known about this engine, but the existence of one detail is definitely established. Writing to David Giddy, generally known as Gilbert, who was afterwards President of the Royal Society, Trevithick, on February 20th, stated that the discharged steam was turned up the chimney, and that "the fire burns much better when the steam goes up the chimney than when the engine is idle." On March 4th he wrote that the steam "makes the draught much stronger by going up the chimney." Subsequently, Gilbert examined the engine and wrote to William Nicholson¹⁶ that the waste steam was discharged *upwards* into the chimney about 1ft. above its junction with the boiler. Several persons observed that the fire brightened at each stroke of the piston. Trevi-

thick himself, in his evidence before the Committee of the House of Commons in 1831 on "Steam Carriages," stated that he used a "force-draught" created by the steam, for the purpose of working on the roads without a high chimney.

An existing memorandum by Simon Goodrich contains a pencil sketch¹⁷ of another Trevithick engine for driving a coach. The sketch was probably made in 1803, and shows an exhaust pipe going to the chimney, but does not show whether it was turned up inside the latter.

It is true that John Farey¹⁸ in his evidence before the above-mentioned Committee, stated that "the waste steam was commonly discharged into the bottom of the chimney in Trevithick's high-pressure engines . . . but was not discharged through a contracted orifice to give it velocity, nor was it directed upwards, as is now done by Mr. Stephenson." Farey appears to have been referring to Trevithick's stationary engine practice, and in Rees' "Cyclopædia" (1819), his sectional drawing showing the exhaust pipe not turned upwards is described as that of the dredger engine. But in any case, Gilbert's evidence in regard to the Pen-y-darran locomotive is conclusive.

Trevithick's exhaust pipe was so arranged that it produced a "blast" with consequent draught on the fire. It matters not whether it was subsequently termed an "exhausting" or an "eduction" pipe. The effect was there in nature and quality. It has been argued¹⁹ that no mention of the blast pipe was made in Trevithick and Vivian's 1802 patent, and that therefore Trevithick did not comprehend the significance of the blast. But the Pen-y-darran locomotive was not made until the end of 1803, and did not start work until February, 1804. The effect of the exhaust was not discovered until the latter date, but it was immediately noted by Trevithick as soon as the engine started work, and was considered of sufficient importance to merit special mention in both letters to Gilbert.

We now go north to Wylam Colliery, for which Blckett had a locomotive constructed of Trevithick's design. It was built at Whinfield's Foundry, Gateshead, under the superintendence of John Steel,²⁰ between October, 1804, and May, 1805. W. W. Tomlinson,²¹ giving as a reference the *Newcastle Courant*, June 3rd, 1815, states that Trevithick sent drawings and patterns to John Whinfield, whom he had appointed his agent for the North of England in 1803, and

¹⁴ Some doubt has been expressed as to whether these springs were not fitted some months after the engine was built. See Young, page 387; also Warren, page 123. Plate springs appear to have been first used by Nicholas Wood at Killingworth.

¹⁵ *THE ENGINEER*, April 29th, 1910, page 432.

¹⁶ Nicholson's "Journal," September, 1805, Vol. XII., pages 1 and 2. Colburn, "Locomotive Engineering," pages 13-15.

¹⁷ Contributed to the Journal of the Newcomen Society, Vol. 1 (1920-1), by Mr. E. A. Forward, A.R.C.S., of the Science Museum, South Kensington.

¹⁸ Quoted in "A Century of Locomotive Building by Robert Stephenson and Co.," page 224.

¹⁹ "Timothy Hackworth and the Locomotive," page 214.

²⁰ Nicholas Wood "On Railroads," 1st edition, page 130, states that the engine was built by Trevithick and sent north.

²¹ "The North-Eastern Railway: Its Rise and Development," pages 19, 20.

commissioned the latter to manufacture the engine. John Steel was stated to have worked at Pen-y-darran on the construction of the Merthyr locomotive, and the drawings, from which the Gateshead engine was actually built, may have been made by the latter from Trevithick's particulars. That Trevithick had an intimate connection with it, is proved by his visit to Newcastle in 1804, and his reference to an intended further visit in February, 1805. The important point is that if the engine was built in accordance with Trevithick's plans and instructions it would certainly have been provided with a chimney exhaust which he always employed. Moreover, John Steel could hardly have failed to note the exhaust arrangement of the Pen-y-darran locomotive, though the Gateshead drawing shows no exhaust pipe.²² This locomotive was tried in steam in the foundry yard, but Mr. Blackett, for some unknown reason, did not accept it at Wylam.

The exhaust pipe in the chimney was stated to have been applied in 1813 by Hedley to the first of the Wylam-built "grasshopper" engines, which was put into service in May, 1813, and it was stated that "the blast was added soon after the engine commenced work."²³ The exhausts from the two cylinders were combined into one pipe which passed into the chimney. It is impossible to state definitely that the chimney exhaust was copied from Trevithick's locomotives, of which both Blackett and Hedley must have had some knowledge. But Gilbert's observations had been published by Nicholson, and the latter had taken out a patent, so that, as Colburn pointed out, "the action of the exhaust steam in the chimney of a locomotive was well known in 1813." Blackett was constantly on the look-out for anything which would assist steam locomotion, and it would be surprising to find that he had not heard of it. On the other hand, if the "blast" was added subsequently, as is implied by Archer's statement, it would appear that the exhaust was at first turned into the atmosphere, and later, to get rid of the nuisance, into the chimney. This points in the direction that Trevithick's lessons had not been learnt, and to a "rediscovery" of the effect of the blast, similar to that made more than nine years previously. Apparently very little "blast" was necessary in these return flue engines, since the arrangement was again altered and the steam turned into a cylindrical silencer, whence it passed gradually into the chimney. This later method was certainly not a "blast," as the steam jet action was thereby suppressed in order to reduce the noise.

In George Stephenson's first Killingworth locomotive of 1814, the exhaust, according to Colburn, does not appear to have been turned into

the chimney. But in 1815 it was so directed, and Nicholas Wood, in 1825,²⁴ wrote:—"To effect a greater rapidity, or to increase the draught of the chimney, Mr. Stephenson thought that by causing the steam to escape into the chimney through a pipe with its end turned upwards, the velocity of the current would be accelerated, and such was the effect." Wood's statement is a sufficient reply to those who afterwards asserted that Stephenson before 1827 did not understand the effect of the exhaust pipe, otherwise the blast, in stimulating the fire. It has sometimes been forgotten that in the early locomotives with single and even return flue boilers very little blast could be used with success. A blast of the force with which we now visualise it in connection with multi-tubular boilers would have pulled most of the fire up the chimney.

In the 1815 engine Stephenson, according to Wood's illustration, used a single pipe into which the exhausts from both cylinders were led. In the Stockton and Darlington engines of 1825-6 the exhaust from each cylinder was taken independently to the chimney, in which the two pipes were turned up, one at each side.

It is not reasonable to maintain that two separate exhaust pipes cannot be regarded as blast pipes, though the quantitative effect, as measured by the volume of entrained gases, may be different. Such double blast pipes were used on locomotives long after John W. Hackworth started the "battle of the blast pipe" in *The Engineer* of 1857, in which he made a special point of this question. The Grant Locomotive Works, U.S.A., used double blast pipes successfully, and an illustration of one is given in Forney's "Catechism of the Locomotive," 1883 edition, Fig. 95, page 168. A blast pipe by Heusinger v. Waldegg used in Germany had a partition which completely separated the right and left-hand exhausts. In neither of these cases was either exhaust central with the chimney. It is true that the experience of locomotive engineers throughout the world has proved the single central exhaust to be the better, and the reasons why were clearly demonstrated by the experiments of Dr. Goss at Purdue University.

Who was the first to place the blast pipe orifice centrally with the chimney? Timothy Hackworth did so in the "Royal George" of 1827, and his claim was vigorously put forward by J. W. Hackworth in 1857, though the latter did not support it with independent evidence that the central position had not been used previously. On the other hand, in 1830, Robert Stephenson²⁵ wrote that an increase in the temperature of the fire "was effected, shortly after the first locomotive engine was tried on the Killingworth Colliery Railway, by convey-

²² "Timothy Hackworth and the Locomotive," page 38.

²³ "William Hedley, the Inventor of Railway Locomotion," by M. Archer, third edition, footnote page 11. The whole history of the first Blackett-Hedley engines is very unsatisfactory.

²⁴ "Practical Treatise on Railroads," 1825 edition. A copy of the page containing the complete statement is given by Warren, page 26.

²⁵ "Observations on the Comparative Merits of Locomotive and Fixed Engines," Robert Stephenson and Joseph Locke. The complete quotation is given by Warren, page 225.

ing the steam into the chimney, where it escaped in a perpendicular direction up the centre. . . .” Here also there is no independent evidence, though it should be added that in 1830 R. Stephenson was writing of an arrangement which had been applied not many years previously, whereas in 1857 J. W. Hackworth was writing of events which took place when he was only seven years old.

It is not unlikely that Trevithick’s Pen-y-darran locomotive may have had a central exhaust orifice, for the reason that all known drawings of his locomotives show chimneys of small diameter, in which a turned-up pipe would necessarily be in or nearly in that position. Similarly the chimneys of the Wylam engines were of moderate diameter, and there is no evidence that a central exhaust was not used there in 1813.

The credit for coning or tapering the blast pipe to form a contracted orifice is undoubtedly due to

Timothy Hackworth in 1827, and was acknowledged by Robert Stephenson himself.²⁶

To sum up: All the available evidence goes to show that the blast pipe was not *invented* by any one, but was an accidental discovery by Richard Trevithick, and its effect was known in 1804. It was either copied, or independently rediscovered in the same accidental manner, first at Wylam, where Timothy Hackworth was then employed, and then shortly afterwards by George Stephenson. The question as to the priority of placing the upturned pipe centrally with the chimney cannot, so far, be definitely answered. The final improvement of the contracted orifice in so far as it was applied to an exhaust steam or blast pipe, was Timothy Hackworth’s, and this improved form of blast pipe may fairly be described as an invention.²⁷

²⁶ R. Stephenson’s letter to S. Smiles, written in 1858, is quoted in full by Warren, page 227.

²⁷ The sketches attached to Nicholson’s patent of 1806 show a *tapered* orifice, from which a jet of *live* steam issued.

Chapter II — 1828-31

ENGINES WITH INCLINED CYLINDERS: THE "LANCASHIRE WITCH."—On his return from South America Robert Stephenson took charge of the Newcastle locomotive works early in 1828, and from that time he was mainly responsible for the locomotive developments introduced by his firm.

Robert Stephenson's first great improvement was the placing of the two cylinders outside in an inclined position at the rear end of the engine, where they were attached to the boiler at an angle of 39 deg. by means of a long bracket. The cross-

boiler was 9ft. by 4ft., and contained two flues, somewhat after the fashion of a Lancashire boiler. Total heating surface 66 square feet; grate area 12 square feet. The exhaust passed through pipes into the chimney, but, in addition to such blast effect as this arrangement produced, forced draught was applied by bellows placed under the tender and worked by excentrics. This addition was provided to overcome difficulties anticipated with coke burning, but was afterwards abandoned as inconvenient and presumably unnecessary.

Coste and Perdonnet state that this engine had

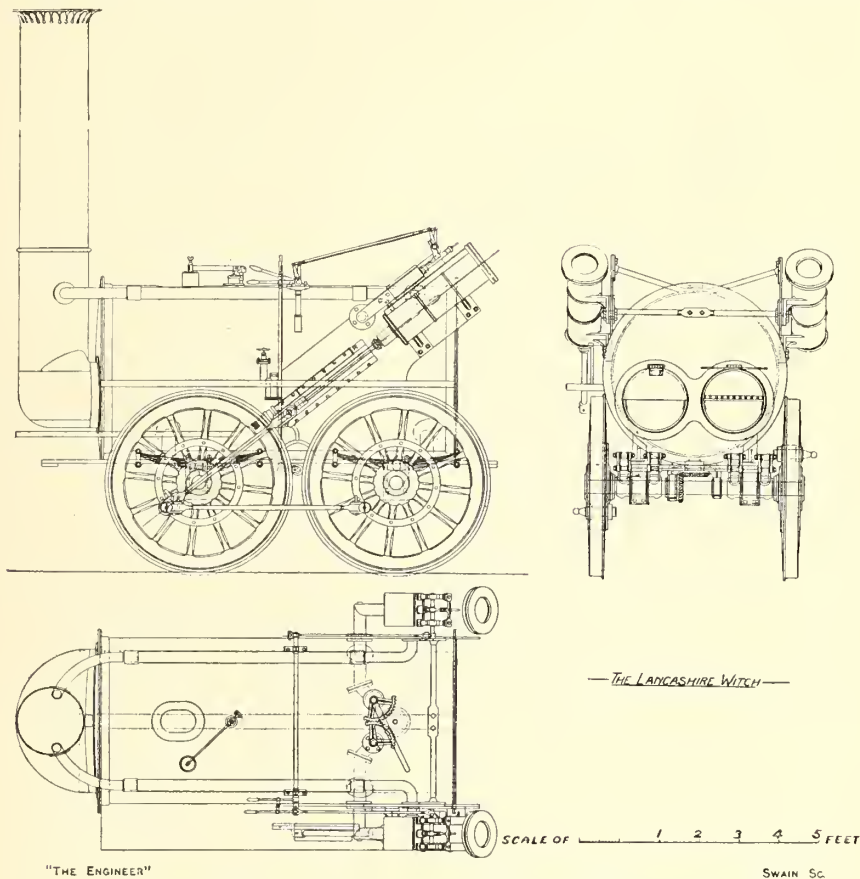

FIG. 4—BOLTON AND LEIGH RAILWAY "LANCASHIRE WITCH," 1828

From "A Century of Locomotive Building," by permission of Robert Stephenson & Co., Ltd.

head was guided by slide bars. The first engine of this type was the "Lancashire Witch"—Fig. 4—built in 1828, and used on the Bolton and Leigh Railway. It was carried on four coupled wheels 4ft. diameter, with wood spokes and iron tires. The cylinders were 9in. by 24in., and the piston-rods were directly connected to the front wheels by the usual rods. Both axles had springs above the bearings which were inside the wheels. The

a single steam distribution chamber common to both cylinders, and also describe a crude method of working the steam expansively. "On one of the axles is fixed a toothed bevel wheel which turns another bevel wheel placed horizontally and attached to a vertical shaft, which—passing through the boiler—operates a rotating plug valve; by means of this valve it is possible to obtain the expansive action of the steam during

half the stroke of the piston. . . . There are two toothed quadrants which the enginemen, by a handle, can turn through a quarter of a revolution about their centres; in their first position they permit the rotating valve to produce its effect by causing the steam to work by expansion; in the second position they prevent this, and the steam acts only by the effect of its elasticity on its entry into the cylinder."¹

The locomotive "America,"² built by Messrs. Stephenson in 1828 for the Delaware and Hudson Canal Company (4ft. 3in. gauge), was in many respects similar to the "Lancashire Witch," and had a primitive single-bar frame.

Stephenson's Six-coupled Engine "Rocket," Stockton and Darlington Railway.—The Stockton and Darlington Railway engine No. 7, "Rocket," built in 1829, at the same time as its more celebrated namesake, also had outside inclined cylinders and several characteristics similar to

two long connecting-rods on each side by means of a long crosshead. Séguin found that the single flue did not produce sufficient steam, and designed a multitubular boiler, which he patented in 1828; but in his book "De l'Influence des Chemins de Fer" (1839) admits that the first application of a multitubular boiler to a locomotive was made on the Liverpool and Manchester Railway (see *The Engineer*, December 14th and 21st, 1923). The first multitubular boiler was patented by James Neville in March, 1826.

Hackworth's Six-coupled Engine "Victory," Stockton and Darlington Railway.—The "Victory," No. 8, of the Stockton and Darlington Railway, was built at Shildon in 1829 by T. Hackworth, on the same general lines as the "Royal George," but instead of parallel motions the piston-rods were provided with crossheads which embraced rods or "slide bars" of circular section. The vertical cylinders were 12in. by

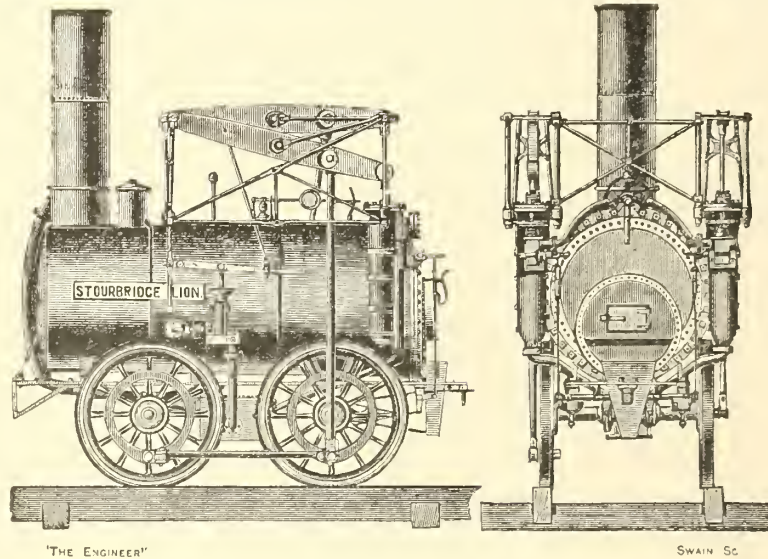

FIG. 5.—FOSTER AND RASTRICK'S "STOURBRIDGE LION," 1829

those of the "Lancashire Witch," but there were six-coupled wheels, and the boiler was of the return flue type. Warren, who illustrates the engine, points out that it had an "arrangement for expansive working by cut-off in the steam pipe, by means of a mushroom valve operated from a cam on the trailing axle, a simplified development of the principle applied in the "Lancashire Witch."³

*Stephenson's Locomotives for France, 1828-9.*⁴—These interesting engines, supplied to the orders of Marc Séguin, had four wheels and an inside frame, apparently of wood. The vertical cylinders were placed between the wheels. The piston-rods issued from their upper ends and actuated

22in., and the boiler, 12ft. 6in. long by 4ft. 4in. diameter, contained a single return flue. It does not appear from the illustration that this engine had springs.

Later Engines of the Killingworth and Wylam Types, 1829 to 1831.—Although Hackworth with the direct drive of the "Royal George," and Stephenson with inclined cylinders and slide bars, had greatly simplified the earlier complicated locomotive mechanisms, the latter still held their ground with other constructors. In 1829 Foster and Rastrick, of Stourbridge, constructed four locomotives, which had many features in common with the old Wylam "grasshopper" engines.

³ Warren, page 153.

¹ Quoted from Warren, page 147. A very complete illustrated account of the "Lancashire Witch" is given in this book.

² Illustrated in *THE ENGINEER*, January 31st, 1896, page 123. Additional particulars are given in a paper by L. F. Loree, M.Sc., New York, before the Newcomen Society, 1924.

⁴ These engines are mentioned and described by Warren, Chapter VIII, but page 136 illustrates a locomotive subsequently built by Séguin himself and not the earlier ones by Stephenson, though the latter had a similar cylinder arrangement.

⁵ "Timothy Hackworth and the Locomotive," page 180.

The first of these engines was exported to the United States a few months after Stephenson's "America," and, owing to the delays in completing the Delaware and Hudson Railroad, was actually tried in steam in August, 1829, before the latter. The "Stourbridge Lion"—Fig. 5—had a single furnace, branching into two flues which joined again under the chimney. The outside vertical cylinders were about $8\frac{3}{4}$ in. diameter by 36 in. stroke, but owing to the connection with the levers—shown in the illustration—the working stroke at the wheels was reduced to 27 in. Unlike the Wylam engines the connecting-rods worked directly on to crank pins in the hind wheels and

used for the leading axle. The original frame or carriage was of a light bar construction.

The very similar "Agenoria" was built for the Earl of Dudley's Colliery Railway at Shutt End, and has undergone certain modifications from its original condition. These consist chiefly of a new inside sandwich frame, new cast iron wheels with ordinary spokes, and balance weights provided for the rear driving wheels. The "Agenoria" worked from June, 1829, for about thirty years, and is now preserved in the Science Museum, South Kensington.

According to the *Mechanics' Magazine*, these engines had mechanical lubricators for the axle-

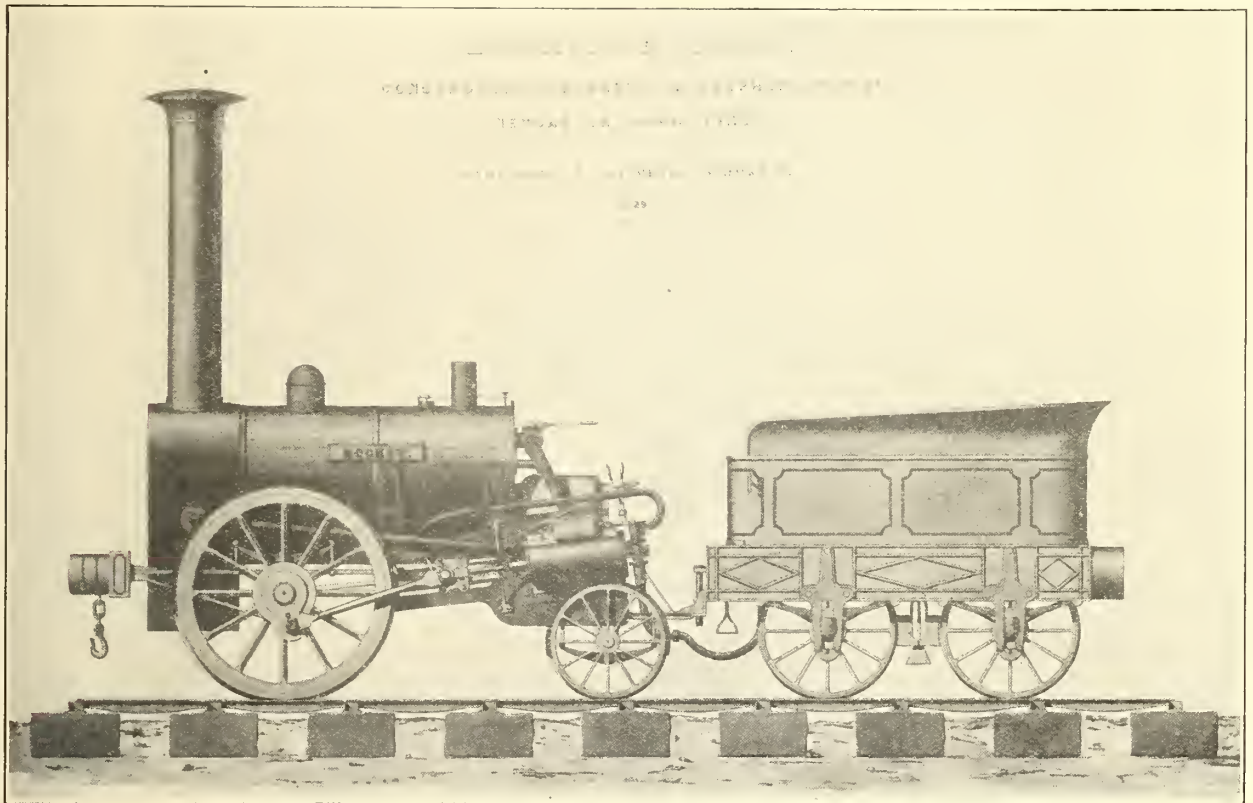

FIG. 6.—THE "ROCKET," LIVERPOOL AND MANCHESTER RAILWAY, AS REBUILT AFTER 1829

This drawing is believed to be the one made to the order of the Directors of the Liverpool and Manchester Railway in 1836, when they decided to sell that famous locomotive out of their service. It represents the engine after reconstruction, and shows that it was essentially in its present form at that date. The drawing is particularly important in that it indicates the true form of the fire-box.

set at 90 deg. The levers or beams were double, with the crosshead between them, whereas in the Wylam engines the connecting-rods were forked at the top. The slide valves were actuated through a system of rods and levers attached to loose excentrics placed upon the back or driving axle, and controlled by stops fixed to the axle which retained them in position for fore and back gear. Hand gear was used to work the valves when reversing until the stops came into action.

The original wheels appear to have been built up of wooden rims with wrought iron bands and spokes let into cast iron naves, and springs were

boxes, the gear for which still exists in the "Agenoria."

The simple Killingworth type of engine, with plain guides for the piston-rods, was revived in 1831 on the Monkland and Kirkintilloch Railway in the case of two engines built by Murdoch and Aitken, of Glasgow, to the designs of Mr. Isaac Dodds. These were the first locomotives built in Scotland. The wheels had a lateral play of about 1 in. to allow for the sharp curves on the line, and the coupling rods worked on spherical pins to provide for this lateral motion. The valves were actuated by tappet gearing moved by the excent-

trics. The piston packings consisted of a pair of iron rings cut into three segments, with a small wedge-shaped filling piece separating each segment. The segments were kept tight against the walls of the cylinder by means of small springs. The cylinders were 10½ in. by 24 in., the wheels 3 ft. 3 in. diameter, and the pressure was 50 lb. per square inch. These engines were stated to have given "very high satisfaction to the proprietors of the railway, as performing more work than the engineers undertook they should execute."⁶ Incidentally, this proves that these old Stephenson type locomotives were not so inefficient as the detractors of the first four Stockton and Darlington engines so frequently asserted.

Liverpool and Manchester Railway: Rainhill Trials.—Partly owing to the disquieting rumours which had been spread abroad of the failure of locomotives on the Stockton and Darlington Railway, the Liverpool and Manchester directors seriously considered the use of stationary engines. At the Franco-British Exhibition in 1908, the London and North-Western Railway Company showed a number of original letters and estimates from George Stephenson relating to the cost of working goods traffic by stationary and locomotive engines. The expenses per ton for the whole distance, using fixed engines, was estimated to amount to 7.86d., and with locomotives 4.43d.

It is not necessary to repeat the well-known story of the Rainhill trials. Nevertheless, a survey of the conditions and a comparison of the three locomotives which competed, are essential in any historical account of locomotive development.

The engine, the price of which was not to exceed £550, had to consume its own smoke, and if of 6 tons maximum weight allowed, had to draw 20 tons load, including tender and water tank, at 10 miles per hour, with a boiler pressure not exceeding 50 lb. per square inch. An engine of less weight was to be preferred, and if the weight did not exceed 4½ tons, the engine might be placed on four wheels, and draw a proportionate load. The engine and tender to be supported on springs, and the company were to be at liberty to test the boiler to 150 lb. per square inch.

The "Rocket."—The main features of the "Rocket"—Fig. 6—as originally built, were the "single" driving wheels and the inclined cylinders on a similar principle to those of the "Lancashire Witch," but with slide valves underneath. In *The Engineer* of February 2nd, 1885, the late T. W. Worsdell, then chief locomotive superintendent of the Great Eastern Railway, contributed a full description of the "Rocket" in the form of a specification, which may have been handed on to him by his father, one of the chief officials of the Liverpool and

Manchester Railway in its early days.⁷ From this the following abridged particulars have been taken:—

Motion bars and connecting-rods, wrought iron. Brass slide valves worked by loose eccentrics, actuated by drivers screwed into driving axle. To reverse the engine, the eccentric rods were lifted out of gear and the slides moved by hand. Framing of wrought iron bars, 4 in. by 1 in., bent to support fire-box and to take the hind wheels. Whole weight supported by four steel springs, of plates ¼ in. thick at centre and tapered towards ends. Driving springs placed above, and trailing springs below axles.

Copper fire-box, with water spaces at sides, top, and back, about 2½ in. wide. Front of fire-box lined with fire-brick. Two copper pipes, one on each side, supplied the fire-box with water from the boiler, and two other copper pipes connected the top of the fire-box with end of boiler, to allow steam generated in fire-box to pass into boiler. Steam from boiler admitted to cylinders through copper pipe, branching from a cock on end of boiler above fire-box. An internal steam pipe led from steam dome on the top of the boiler to the regulator. The exhaust pipes from cylinders to chimney were of copper.

The following paragraph is worth noting:—
"There were two cast iron blast pipes fixed inside the chimney, their diameter at the narrowest part 1½ in. No alterations were made in these pipes from the time it left the works until it won the prize."

The particulars of the boiler fittings are also of interest.

Two safety valves, about 2½ in. diameter, one a lock-up valve covered by a tin dome fastened down to the boiler by two small padlocks: the other a lever valve fixed to boiler near fire-box end.⁸

A mercurial gauge was fixed on the side of the chimney, and was nearly of the same height, the bottom of the gauge resting on the frame. A small copper pipe, about ¾ in., connected the bottom of the gauge with the bottom of the boiler. A water gauge was fixed on one side of boiler at the back of the cylinder. Two gauge cocks were

⁷ This "specification" is referred to by Warren (page 217 *et seq.*) as the "Particulars." The date of the document cannot be fixed beyond the fact that it existed in 1859. Mr. Warren, with whom the writer has discussed it, thinks that it probably emanated from R. Stephenson and Co.'s drawing-office about 1859. The writer suggests that it may be of considerably earlier date and may have been prepared in 1836, at the time the "Rocket" was sold to Mr. James Thompson, of Kirkhouse, Brampton, Cumberland, when the Liverpool and Manchester directors "ordered that a good drawing should be made of the 'Rocket' to exhibit the form and construction of the first engine employed on the railway" (Fig. 6, page 11). This may account for the record in the possession of Mr. T. W. Worsdell, whose father was then coaching superintendent of the Liverpool and Manchester Railway.

⁸ The lock-up valve had elliptical leaf springs, and the lever valve had dead weights threaded upon the valve spindle and steadied by an external case (W. P. Marshall, "Proceedings," Inst. C.E., Vol. 133, page 260).

⁶ "The Engineers' and Mechanics' Encyclopædia," Luke Hebert, 1849 edition, in which these engines were illustrated. The same illustration also appears in "A Story of Railway Pioneers," by Major Snell, M.C.

also fixed to the side of the boiler near the chimney end.

One brass feed pump was fixed between the motion bars and boiler, and worked from the crosshead. The pump had mitre valves, the lift of which was regulated by small spiral springs. A leather hose connected the copper suction pipe with the tender.

"The tender consisted of a large water barrel fixed to a wooden frame, carried by four cast iron wheels having *outside bearings*, the first ever made." (This tender was made at Liverpool, and not at Newcastle.)

The "Rocket" had cylinders 8in. diameter by 17in.⁹ stroke, 4ft. 8½in. driving wheels, boiler 6ft. long by 3ft. 4in. diameter, twenty-five copper tubes 3in. diameter, fire-box 2ft. long by 3ft. wide by 3ft. deep. The tube heating surface was 117¾ square feet, and that of the fire-box 20 square feet. The total weight of the engine in working order was 4 tons 5 cwt., and of the tender 3 tons 4 cwt.

A detail not mentioned in the above specification is that the driving crank pin was spherical. A parallel pin was used for the crosshead gudgeon. The bar frames, as in the "Lancashire Witch," should also be noted. They had points in common with Bury's frames, but the axle guards were of cast iron.

The tubular boiler was the most important improvement. It was suggested by Mr. Booth, the secretary of the railway, but there is no evidence to show that he was acquainted with Séguin's prior invention. The locomotive by the latter fitted with a multitubular boiler was not tried until two months after the "Rocket," and Perdonnet suggests that "the idea may have occurred simultaneously to two men of genius."¹⁰

The question whether the "Rocket" was fitted with blast pipes when originally built has been the subject of acrimonious controversy. Each cylinder had a separate exhaust into the chimney. This has already been discussed in Chapter I, and nothing further need be said beyond quoting the following statement by Robert Stephenson himself¹¹:-

"During the construction of the Rocket a series of experiments was made with blast pipes of different diameters, and their efficiency was tested by the amount of vacuum that was formed in the smoke-box.¹² The degree of rarefaction was determined by a glass tube fixed to the bottom of the smoke-box and descending into a bucket of water, the tube being

open at both ends. As the rarefaction took place the water would, of course, rise in the tube, and the height to which it rose above the surface of the water in the bucket was made the measure of the amount of rarefaction. These experiments certainly showed that a considerable increase of draught was obtained by contracting the orifice, and accordingly the two blast pipes in the 'Rocket' were contracted slightly below the area of the steam ports, and before she left the factory the water rose in the glass tube three inches above the water in the bucket."

In the same statement Robert Stephenson conceded Hackworth's claim that the *contraction* of the orifice was due to the latter on the Stockton and Darlington Railway. He also added that the subsequent alteration of the two blast pipes into one was made by himself with a view to lessening the space occupied by them in the chimney.

There are two points relating to the manufacture of the "Rocket" which deserve notice, and are mentioned at some length in the letters of Robert Stephenson to Mr. Booth exhibited at the Franco-British Exhibition. In the first place, the detail weights of the engine were carefully estimated. He wrote:-"After weighing such parts as are in progress, the following is an estimate of the weight:-

	c.	q.	lb.
Boiler without the tubes	9	3	7
Twenty-five copper tubes	4	2	22
Frame carriages and bolts	4	3	3
One pair of 4ft. 8½in. wheels and axle ...	13	1	0
One pair of wagon wheels and axle ...	5	0	0
Four springs and bolts	2	0	20
Copper fire-place, including bars	6	0	0
Chimney and soot	2	0	0
Four supports for boiler on frame ...	1	2	4
Two engines complete, each 8 cwt. ...	16	0	0
Water in main boiler	11	3	0
Water in copper fire-box	3	0	0
	Cwt.	80	0 0

"This weight, I believe, will cover everything. The wheels I am arranging so as to throw 2½ tons upon the large wheels in order to get friction upon the rail." At the trials the "Rocket" weighed 85 cwt., being 5 cwt. more than the estimate, but less than the 4½ tons stipulated in the conditions for a four-wheeled engine.

The second point relates to the excessive test pressure of 150 lb. per square inch specified in the conditions. This was three times the boiler pressure. The letters show that great difficulty was experienced in fulfilling this test in the works. At 70 lb. the end bulged out ¾₁₆in. and injured the "clinking" of the tubes. At first five extra stays were added, but when tested to 120 lb. the trouble recurred and two more stays had to be inserted to make the end withstand 150 lb. pressure. These additional stays would account for some of the extra weight above that calculated.

T. Hackworth's "Sanspareil" (Fig. 7).—This was a four wheels coupled engine with 4ft. 6in. wheels, having wooden spokes. The cylinders, 7in. diameter by 18in. stroke, were placed vertically above the axle at the end furthest from the chimney. A feature in the design of the cylinders which does not appear to have attracted much

⁹ The stroke appears to have been reduced to 16½in. at a later date unknown, and the springs below the trailing axle were removed.

¹⁰ Warren, page 139. See also THE ENGINEER, December 14th and 21st, 1923.

¹¹ Smiles' "Lives of the Engineers," 1862 edition, Vol. III., page 501. The complete letter, of which only a small portion is given above, is quoted in full by Warren, pages 226-7.

¹² This was an error on the part of Stephenson, who forgot, when writing nearly thirty years after the event, that the "Rocket" in 1829 had no smoke-box. The tube would be fixed in the chimney at the point where it issued from the lower part of the boiler.

attention was the extremely large clearance space. Although the stroke was only 18in., the inside length of the cylinder was about 2ft. 4in.¹³

The boiler was 6ft. long by 4ft. 2in. diameter, with a return flue. The fire-grate was enclosed in one "leg" of the flue, and the other "leg" terminated in the chimney at the same end as the grate. The latter projected about 3ft. beyond the end of the boiler and had a semi-circular water casing over the top and sides, leaving the fire-grate open below. The return flue also extended about 2ft. beyond the boiler before it joined the chimney, and had a water space all round the projecting portion. All the illustrations of the engine show a plain ledge at the cylinder end, which served as the driver's platform. The fireman stood on the tender, which was coupled to the opposite or chimney end. There was no framing, and the axle bearings (as the engine exists to-day at South Kensington) are in wrought iron sockets riveted to the boiler. Another omission from the drawings is that of springs, which were specified as one of the conditions of the trials. Seeing that these conditions had to be complied with it is possible that the pair of wheels at the chimney end were provided with them, but it is by no means so certain that there were springs for the driving axle, since the position of the cylinders would have caused so much vertical oscillation that grave results must have ensued at the speeds required on the Liverpool and Manchester Railway. The "Royal George," which was a slow-speed coal engine, had no springs for the driving axle.

The old drawing of the "Sanspareil," presented by the late John Hick to South Kensington Museum, shows no sign of springs on either axle, and John Dixon wrote in October, 1829, that he could see no springs on the engine. The "axle-boxes," or rather bearings, in the existing engine are bolted on to the boiler and have no guides such as would be necessary if there had been springs. On the other hand, the excessive clearance space between the piston and the cylinder covers appears to show that allowance was intended for vertical movement of the boiler, to which the cylinders were fixed, relatively to the wheels.

The "Sanspareil" was disqualified at the Rainhill competition owing to non-fulfilment of the conditions. Apart from the fact that the weight was greater than the stipulated amount, the question also arises whether the absence of springs may not also have influenced the judges.

The coupling rod pins in both leading and driving wheels were spherical. The valves were actuated by loose eccentrics on the driving axle.

The engine was provided with a single blast pipe with contracted orifice turned upwards in the centre of the chimney. A vertical cylindrical vessel was fixed on the back of the boiler for the purpose of collecting condensed steam from the



FIG. 7—THE "SANS-PAREIL," BY T. HACKWORTH, 1829

exhaust pipe. It was connected to one of the feed pumps and may be described as a variation of the arrangement on the "Royal George," in which part of the exhaust was passed directly into a feed tank. The fire-grate had an area of 10 square feet and (quoting Colburn) "that part of the flue answering to an ordinary fire-box was 15.7 square feet in extent, while the remaining part of the flue measured 74.6 square feet." The weight in working order was 4 tons 15½ cwt., and therefore exceeded the 4½ tons limit imposed by the conditions of the trials.

Braithwaite and Ericsson's "Novelty" (Fig. 8).—This engine had two vertical cylinders, though it has been frequently credited with one only. The spring gear was probably the best of any of the competing engines. The following interesting description is taken from "The Engineers' and Mechanics' Encyclopædia"¹⁴:—"To prevent the effect of the springs from counteracting the action of the engine, the connecting-rods (note the plural) were placed as nearly as possible in a horizontal position, and the motion is communicated to them by bell cranks on each side of the carriage,

¹³ For this and other information the writer is indebted to Mr. E. A. Forward, M.I. Mech. E., of the Science Museum, South Kensington.

¹⁴ For further particulars of the "Novelty" and its subsequent history see THE ENGINEER, January 26th, 1906, page 82.

being connected by slings to the piston-rods." Little further description of this engine need be given beyond pointing out that with the two cylinders there must have been a double crank axle, in which case Braithwaite and Ericsson can justly lay claim to this. In a footnote to page 27 of Colburn's "Locomotive Engineering," the author states that he "was assured by Mr. John Braithwaite that there were two cylinders working cranks at right angles to each other." The illustrations of the engine do not, however, show this important feature. The fuel and the water tank were carried on the engine framing, and the "Novelty" was therefore the first tank engine.¹⁵

A Comparison between the "Rocket" and the "Sanspareil."—The performances of the engines during the trials which ended in the victory of the "Rocket" can be found in various books. The result aroused considerable ill feeling, but it is not

chimney through the cracked cylinder. The "Sanspareil" made steam well, and had a higher rate of evaporation than the "Rocket," but this greater rate may have been partly due to the stronger blast caused by the cylinder accident, if this occurred, of course, at the expense of a heavy fuel consumption.

The wheel base of the "Rocket" was 7ft. 2in. and that of the "Sanspareil" only 4ft. 8½in. Moreover, Hackworth had not calculated the detail weights so carefully as Robert Stephenson, since the "Sanspareil" weighed 5½ cwt. above the stipulated allowance. But the chief fault in the design of the "Sanspareil" was the use of vertical cylinders. The conditions and speeds on the Liverpool and Manchester Railway were different from those of the slow-moving coal trains hauled by the "Royal George" on the Stockton and Darlington Railway, where vertical cylinders would not show

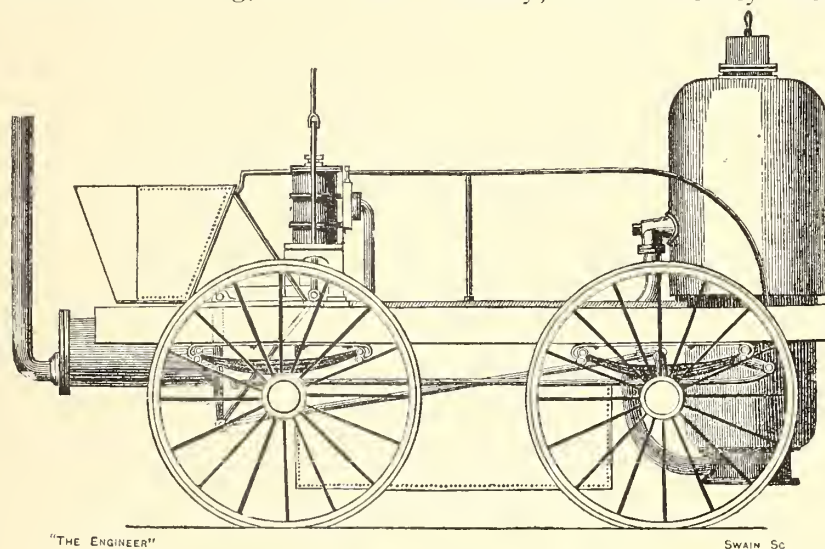

FIG. 8.—THE "NOVELTY," BY BRAITHWAITE & ERICSSON, 1829

necessary to enter here into the causes of it. The only question of importance is, which was the better locomotive—the "Rocket" or the "Sanspareil"—and that question can be examined from a technical standpoint quite apart from the happenings at Rainhill.

Considering the designs impartially, the "Rocket" certainly appears the better of the two. The multitubular boiler in itself was an advantage over the return flue type, and it is also an open question as to whether Hackworth's blast pipe orifice may not have been too contracted for the latter boiler, in which the large flue offered little resistance to the pulling of the fire up the chimney, even with allowance made for the extra blast caused by the direct passage of the steam to the

to such grave disadvantage. Hackworth does not seem to have appreciated this, or he would hardly have made a coupled engine at the cost of the additional weight of the coupling-rods. Stephenson, on the other hand, saw that 2½ tons adhesive weight was sufficient, and boldly designed the first locomotive to have single driving wheels.

John W. Hackworth, the son of Timothy, long afterwards wrote that one pair of the "Rocket's" wheels pressed more heavily on the rails than either pair of the "Sanspareil's." It may be of interest to consider this statement in connection with the use of vertical cylinders, and, of course, without balance weights. From sketches of the details, the writer has calculated that at a speed of 20 miles per hour the combined effect of the revolving and reciprocating parts of the "Sanspareil" resulted in a "dynamic augment" of about 387 lb. on each rail. The corresponding parts of the "Rocket" were considerably heavier, but as a set-off against this the cylinders were

¹⁵ Strictly considered, this statement is correct only if locomotives for public railways are considered. Blenkinsop's rackrail locomotives carried water tanks on the framing in front. See THE ENGINEER, April 29th, 1910, page 432, and November 25th, 1910, page 564.

placed at an angle of 35 deg. with the horizontal. The maximum downward vertical dynamic force of the "Rocket" was about 360 lb. at the same speed. As this force increases as the square of the number of revolutions per second, the difference in favour of the "Rocket" would have been still greater at higher speeds, owing to its larger driving wheels. The comparison cannot be carried further with accuracy, since the static weight on the driving wheels of the "Sanspareil" has not been recorded, though it can hardly have been less than 2 tons 8½ cwt., or 1 ton 4¼ cwt. on each side. The "Rocket" carried 1 ton 5 cwt. on each driving wheel. The total difference in the maximum vertical loads in favour of the "Sanspareil" would in this case be about 57 lb. only, and this

have attained a speed of 30 miles per hour, but it is certain that the original permanent way of the Liverpool and Manchester Railway could not have long withstood the effect of such an engine running at the speed of their faster passenger trains. On the other hand, for slow-speed goods traffic on a line with heavy gradients, the "Sanspareil," with a total adhesive weight of 4¾ tons, might have proved a more suitable engine than the "Rocket." It may have been for the above reasons that the directors of the Liverpool and Manchester Railway, who had purchased the engine from Hackworth for £500,¹⁷ sold it in 1832 for £110 to Mr. Hargreaves, the lessee of the Bolton and Leigh Railway. On this line, where the gradients were heavy and the speeds less, the



FIG. 9—THE "NORTHUMBRIAN," LIVERPOOL AND MANCHESTER RAILWAY, BY R. STEPHENSON AND CO., 1830

difference would disappear as the speed increased to, say, about 25 miles per hour.

If the "Sanspareil" had springs, the engine could hardly have been worked at suitable speeds for any length of time, for with its very short wheel base serious pitching oscillations on the springs would have resulted. Even in the case of the "Rocket," with longer wheel base and cylinders inclined at 35 deg., it was subsequently found necessary to alter the inclination of the cylinders to 7 deg., to lessen the up-and-down thrust, which caused a jumping motion and undue action on the springs.¹⁶ The later engines of the "Rocket" type, built in 1830, embodied this improvement.

The "Sanspareil" in a later trial was stated to

"Sanspareil" worked successfully until 1844.

Although the general design of the "Sanspareil" is open to the above criticisms, in justice to Timothy Hackworth it should be added that in some of the details of his engines, and more especially in thorough and careful workmanship, he was unexcelled.

Later Engines of the "Rocket" Type.—Under this heading are included the four-wheeled engines with outside cylinders at the fire-box end and driving wheels at the chimney end. They were all built by Stephenson in 1830 for the Liverpool and Manchester Railway. The first

¹⁶ Edward Woods in THE ENGINEER, February 6th, 1885, page 95.

¹⁷ Warren, page 81, quotes a letter from one of the directors which states that it was purchased "under a hope that, though manifestly inferior to the successful engine (the "Rocket"), it might be rendered useful," but "has proved of so little value that it has just been sold for £110."

alteration was the lowering of the cylinders to a more nearly horizontal position, and their increase in size in the first four engines of the "Meteor" class to 10in. by 16in., and in two later engines of the "Phoenix" class to 11in. by 16in. The driving wheels in all of them were enlarged to 5ft. diameter. The tubes were increased to eight-eight to ninety-two in number, and the diameter decreased to 2in. The externally attached fire-box, as in the "Rocket," was retained, but the two "Phoenix" engines were provided with smoke-boxes, the first to be made.

The final form of the design is seen in the "Northumbrian," which appeared in August, 1830. This engine had 132 $1\frac{1}{2}$ in. tubes, but the most important alteration was the provision of an internal fire-box. In this engine, therefore, we find the first example of the modern locomotive boiler. The "Northumbrian," which had 11in. by 16in. cylinders, and weighed 7 tons 7 cwt., is illustrated by Fig. 9—from a contemporary etching—the details on which agree well with Stephenson's working drawing.

Braithwaite and Ericsson's "William the Fourth."—Two locomotives—Fig. 10—were built by Braithwaite and Ericsson in 1830 for the opening of the Liverpool and Manchester Railway, but arrived too late to take part in the ceremony. They were named "William the Fourth" and "Queen

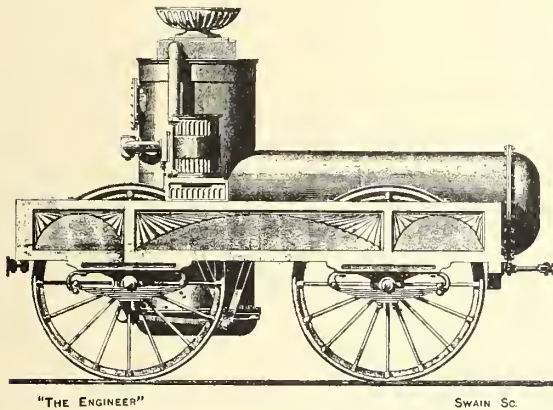

FIG. 10—BRAITHWAITE & ERICSSON'S "WILLIAM THE FOURTH," 1830

Adelaide," and had 5ft. uncoupled wheels and 12in. by 14in. cylinders. They were provided with induced fan draught instead of the forced bellows draught of the "Novelty." Owing chiefly to their inefficient boiler power, they were not a success, and were not retained by the railway. They were subsequently used during the construction of the North Union Railway.

Canterbury and Whitstable Railway: "Invicta."—In May, 1830, R. Stephenson and Co. built the "Invicta" for the Canterbury and Whitstable Railway (Fig. 11). This may be described as a coupled engine of the "Rocket"

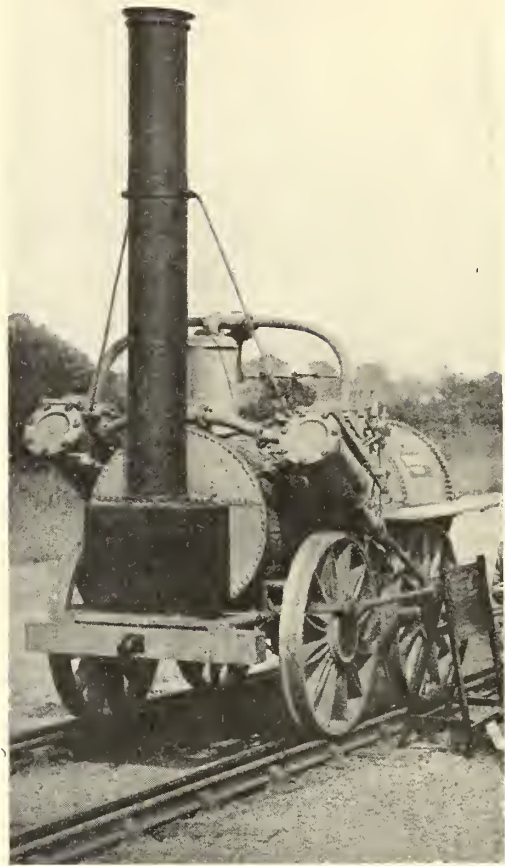

FIG. 11—THE "INVICTA." CANTERBURY AND WHITSTABLE RAILWAY, BY R. STEPHENSON AND CO., 1830

type, but the steeply inclined cylinders, which were 10 $\frac{1}{2}$ in. by 18in., and bolted to two iron frames, were placed at the front end of the boiler instead of at the fire-box end, as in the "Rocket." As originally built, the "Invicta" had a fire-box outside and at the back of the boiler barrel, and the boiler was of the multitubular type, similar to that of the "Rocket." It carried 40 lb. pressure. The coupled wheels had a diameter of 4ft. The wheel base on the original drawing was 4ft. 7in., but when the alterations mentioned below were made, the wheel base was lengthened to 5ft. About 1838 the fire-box and tubes were removed and a cylindrical furnace within the boiler was substituted. From this furnace three tubes extended forward to a makeshift smoke-box underneath the chimney. It was stated that after this alteration there was difficulty in maintaining steam. Wishaw stated that in 1839 the use of the locomotive had been discontinued, but it is still preserved at Canterbury.¹⁸

¹⁸ See THE ENGINEER, October 10th, 1879, page 276.

Chapter III — 1830-37

THREE SCHOOLS OF LOCOMOTIVE ENGINEERS.¹—The division of the history of locomotive development into periods is necessarily arbitrary, since no definite lines of demarcation can be drawn, and in all instances the periods overlap. The previous periods which have been dealt with may be considered as purely experimental, and the third, upon which we are now entering, is, to a large extent, similar, but in it the locomotive as evolved by R. Stephenson and Co. gradually assumes the general form in which we know it to-day. For a few years there were three schools of locomotive engineering, one of which maintained either vertical cylinders, generally with indirect drive, or adopted Stephenson's steeply-inclined cylinders with direct drive. The boilers were of various designs, and Hackworth, its chief exponent, in his mineral engines for the Stockton and Darling-

differences between them lay in the framing and form of fire-box.

Claims in respect of the priority of the combination of inside horizontal cylinders and crank axle have been made on behalf of Bury, Stephenson, and Hackworth. The first engine with these characteristics was Bury and Kennedy's 0-4-0 engine "Liverpool," which was tried on the Liverpool and Manchester Railway in July, 1830, the work on it having been begun in October, 1829. The second in actual service was Stephenson's "Planet" of September, 1830. There is no need to discuss the contention that Hackworth's designs for the Stockton and Darlington engine "Globe" were handed to Messrs. Stephenson, the builders of this engine, before the "Planet" was built. The importance of the subject lies rather in the technical characteristics of the three engines.

Bury's 0-4-0 Engine "Liverpool."—This engine

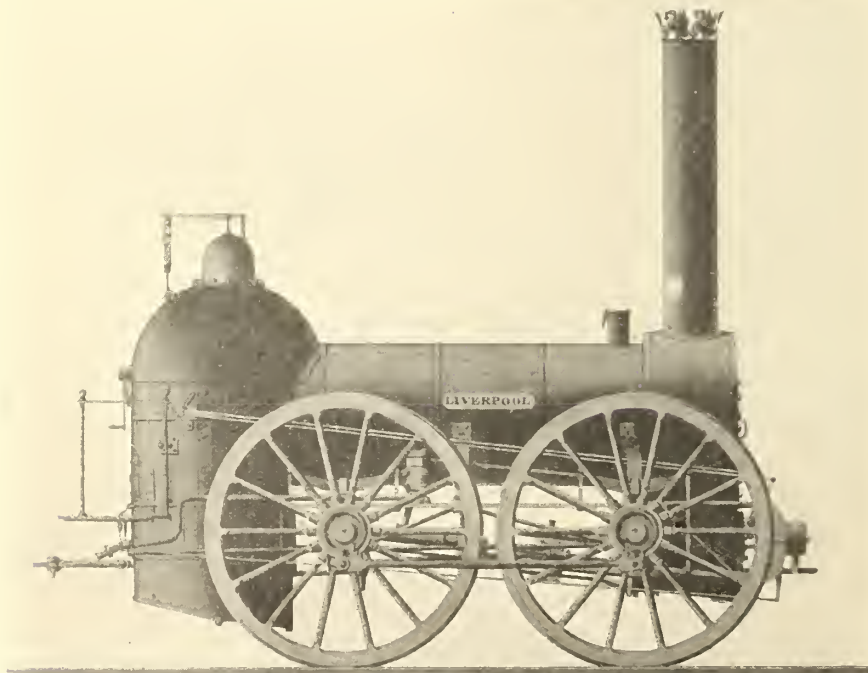

FIG. 12—E. BURY'S 0-4-0 ENGINE "LIVERPOOL," AS REBUILT, 1830

ton Railway, usually adhered to boilers with large internal flues. The other schools, exemplified by R. Stephenson and Bury respectively, adopted horizontal cylinders and crank axles, and their boilers were of the multitubular type. The chief

¹ The expression "Schools of Locomotive Engineers" is due to J. E. McConnell, who used it in his evidence before the Gauge Commission in 1845.

—Fig. 12—had 6ft. coupled wheels, then the largest in the country, and 12in. by 18in. cylinders, inclined slightly upwards to allow the piston-rods to pass underneath the leading axle. The design embodied the well-known bar framing inside the wheels, a feature which will be mentioned later when the subject of framing comes under review. Further particulars were given in *The Engineer* of February 2nd, 1923, but it should be mentioned

here that the multitubular boiler, and possibly the smoke-box also, were subsequent replacements made when the engine was reconstructed a few months after its first appearance. A drawing of the "Liverpool," published in Bourne's "Steam Engine," shows that the cylinders were not entirely enclosed within the smoke-box, as was the case in Stephenson's "Planet" and in Bury's later engines. The later boiler mentioned above also included Bury's well-known D-shaped fire-box with hemispherical top and casing. It must be conceded that Bury's engine, most of the details of which were due to James Kennedy, showed a remarkable advance in locomotive design.

Stephenson's 2-2-0 Engine "Planet."—This engine is shown by Fig. 13 from a drawing by G. H. Phipps,² Messrs. Stephenson's chief draughtsman at the time when it was designed.

The main features were the cylinders, 11 in. by 16 in., which were placed horizontally, and enclosed within the smoke-box, also the first employment of outside "sandwich" frames, with outside bearings, so long a feature of Messrs. Stephenson's designs. These "sandwich" frames were formed of ash or oak planking, strengthened by iron plates on the outside and inside. The axle guards were bolted on to the outside frames. There were four additional inside frames between the smoke-box and fire-box, the bearings in which supported the crank axle on each side of the crank webs. This axle, therefore, had six bearings. In a subsequent design of about 1832,³ the inside frames were of iron only and the inside axle guards were welded on. This was exceptional in locomotive practice of those days, and for many years afterwards it was usual to bolt on the axle guards to both outside and inside frames, though Messrs. Stephenson used welded axle guards for the latter until about 1842. The underhung springs of the "Planet" should be noted.⁴

In regard to the inside cylinders of the "Planet" enclosed within the smoke-box, Robert Stephenson said (Proc. Inst. Mech. E., 1852, page 84) that this arrangement was due to a statement made to him by Trevithick. The latter was repairing an old Cornish engine which, unlike others of this type, had no steam jacket, and therefore he built a brick casing round the cylinder with an air space and applied a fire to keep this air heated. With this air jacket the consumption of fuel was only one-fifth of that with the unjacketed cylinder. Stephenson added that he was so much impressed by this result that he designed the "Planet" with smoke-box jacketed cylinders, and found that considerable increase of power resulted.⁵

The driving wheels of the "Planet" were 5 ft.

and the leading wheels 3 ft. diameter. The boiler contained 129 1½ in. tubes, and the engine weighed about 8 tons in working order.

Hackworth's "Globe."—This locomotive, illustrated on page 3 of Colburn's "Locomotive Engineering," was a four wheels coupled engine, built for passenger traffic on the S. and D. Railway. It had a double-cracked axle and inside horizontal cylinders, but the latter were placed at the back end under the driver's platform. The boiler was of a novel design, with a single flue fire tube, in the back of which the grate was placed. At the front between the fire bridge and the chimney a number of diagonal water tubes traversed the main flue. Colburn states that these tubes were subsequently removed for the reason that they furred up. A copper drum or steam dome, apparently of spherical shape, was placed on the back of the boiler. A similar spherical dome was shown in the original drawing of Stephenson's "Majestic."

The origin of the crank axle has been strenuously claimed both for Bury and Hackworth. But Robert Stephenson pointed out ("Proc.," Inst. C.E., Vol. 16) that neither Bury, Hackworth, nor his own firm could claim it, since it was embodied in Braithwaite and Ericsson's "Novelty." Bury's cylinders, though not quite horizontal, were so nearly so that the earliest combination of horizontal cylinders beneath the smoke-box and crank axle may fairly be claimed for his engine.

Bury's "Liverpool" and Stephenson's "Planet" were the first engines to have a true framing, that is, a structure upon which the boiler was carried. Until that time the boiler had formed the attachment to which the engine and bearings were fastened. The cylinders were not secured directly to the frames, but to the smoke-box, and the latter in the "Planet" was fastened to the outside framing by stays, so that the alternate thrust and pull between cylinders and crank axle had to be transmitted partly in a circuitous path through these stays, and partly, though more directly, through the inside frames.

Bury's engine had no connecting stays at the smoke-box, but the forces were transmitted to the frame through the brackets which connected the boiler to the inside frame. In addition, the top bar of the frame in Bury's early engines was extended backwards to embrace and support the fire-box, to which the draw-bar was directly attached. The "Planet" was the real point of departure from which the modern British locomotive has been derived, in so far as it combined horizontal cylinders encased within the smoke-box, crank axle, multitubular boiler with fire-box inside it, and a framing, which supported the boiler.

In adopting outside frames Stephenson had in mind a safe support for the crank axle in case of breakage of the latter. Warren records at considerable length the differences between Stephenson and Bury on this subject before the Liverpool and Manchester directors, which ended

² Wood's Treatise on Railroads, 1831 edition. Reproduced by Warren, page 254.

³ Warren, page 280, drawing.

⁴ Later engines of the type had springs above the frames.

⁵ Illustrations of details of the "Planet" engine were given in the Proceedings of the Institution of Locomotive Engineers in a paper by Mr. J. G. H. Warren, No. 72, September, 1925, pages 552-3.

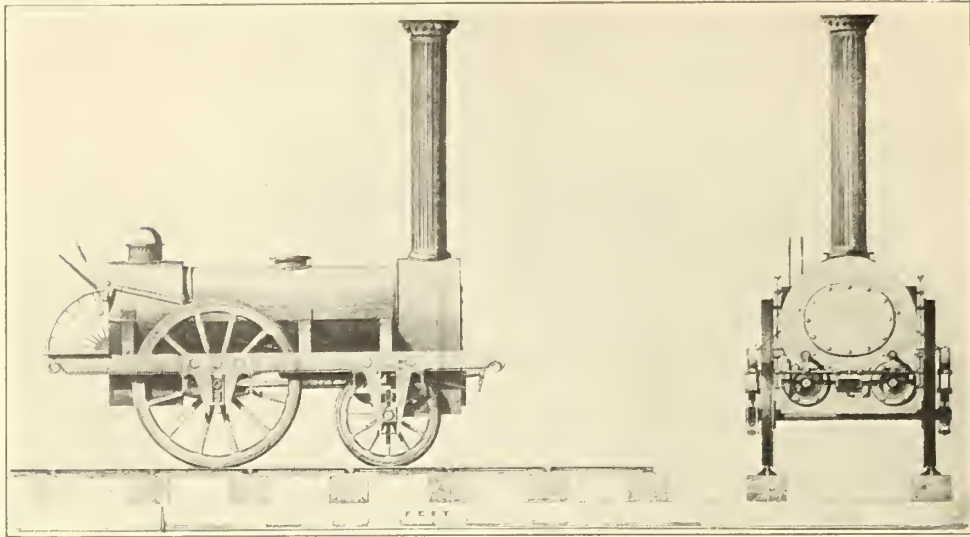
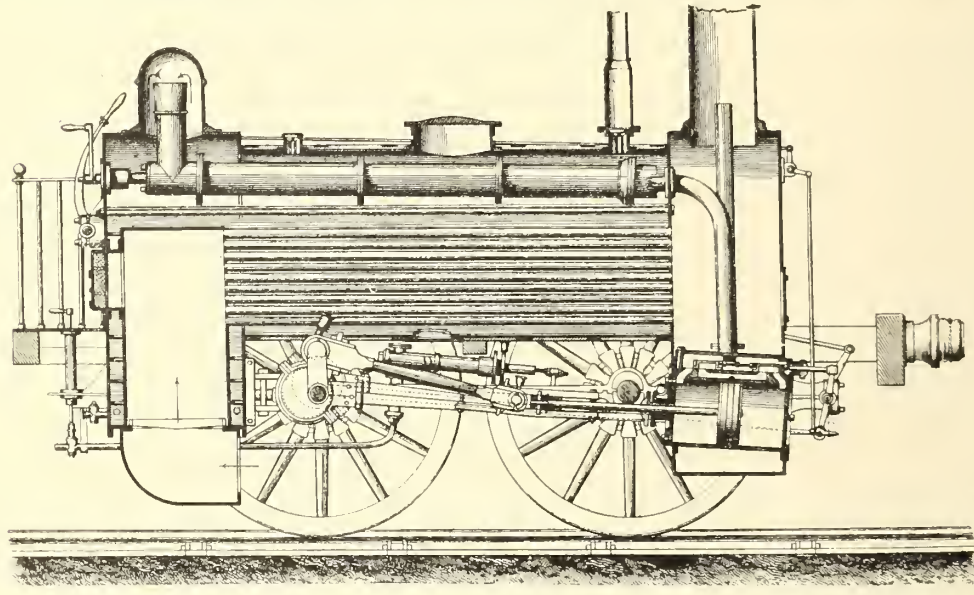

FIG. 13—STEPHENSON'S "PLANET," LIVERPOOL AND MANCHESTER RAILWAY, 1830



"THE ENGINEER"

SWAIN SC.

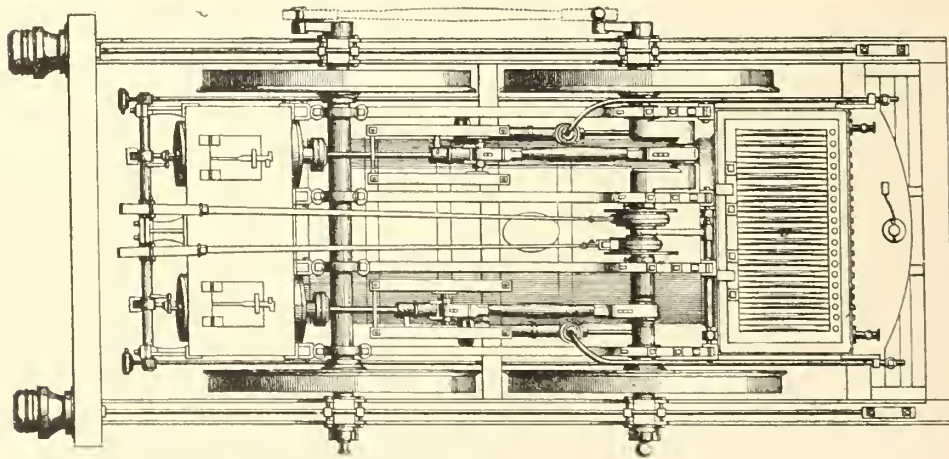

FIG. 14—SECTIONAL ELEVATION AND PLAN OF STEPHENSON'S LATER "PLANET" TYPE 0-4-0 GOODS ENGINE, 1831

in instructions being given to Bury to make the "Liver," which he was to build for that railway, with outside frames.

The disadvantage of four or six bearings at that period was the difficulty of aligning them truly, and any slight deviation from correct alignment caused extra wear on those bearings on to which the additional load was thrown. One cause of this wear was undoubtedly the fact that materials, machine tools, and exact precision of workmanship were not in those days what they now are. On the other hand, Stephenson's outside and inside bearings had one great advantage in case of the breakage of a crank axle, in that the wheels and axle were held in position and the engine did not leave the rails. A circular issued by Bury, Curtis and Kennedy attempted to prove that the reverse was the case, and that Bury's engines did not leave the rails when the crank axles broke. The arguments were extremely far-fetched, and of the nature of commercial pleading.

To *The Engineer* of February 2nd, 1923, the writer contributed an account with illustrations of Bury's engines, in which the bar framing as made by his firm was discussed at some length, and therefore it is not necessary to repeat particulars so recently given. A considerable number of Bury's engines were exported to America, and the bar frames appealed to engineers in that country, where they have become universal.

Stephenson's 0-4-0 Goods Engines, 1831.—In 1831 R. Stephenson and Co. modified the "Planet" type of engine by making the four wheels of equal diameter and coupling them together. Engines of this type, "Samson" and "Goliath," were built for heavy goods and banking work on the Liverpool and Manchester Railway. They had 14in. by 16in. cylinders and 4ft. 6in. wheels, and weighed 10 tons. A similar engine by Stephenson and Co. for the Glasgow and Garnkirk Railway had 11in. by 16in. cylinders.

It may be mentioned here that R. Stephenson and Co. supplied their drawings to various other firms, whom they recommended for orders. Robert Stephenson was himself a partner for a short time in the firm of Tayleur and Co., and amongst other firms which for some time built engines by arrangement with Stephenson's was Fenton, Murray, and Jackson, of Leeds.

The illustrations Fig. 14 have been selected to show the framing which is typical of the later "Planet" and "Samson" type engines. In addition to the outside sandwich frames, which contained the main bearings and carried the weight, the four inside bar "frames," or in reality stays with bearings for the driving axle, extended between the cylinders and the fire-box. Although these stay frames embraced the leading axle, the latter had no bearings in them. In some cases the inside frames had springs to take a small

portion of the weight, and the inside bearings had a double wedge adjustment.⁶

The modification shown in Fig. 14 appears to have had as its object the relieving of the crank axle from bending strains due to the expansion of the boiler. The outside driving cranks for the coupling rods had spherical pins, but the leading cranks had parallel pins.

The cylinders and valves (Fig. 15) merit attention, in that divided slide valves were used, and appear to show that the detrimental effect of

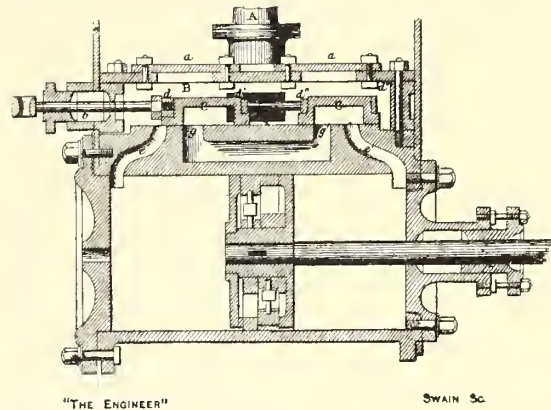

FIG. 15—CYLINDERS AND VALVES FOR STEPHENSON'S "PLANET" TYPE ENGINES, 1831

long ports in adding to the clearance spaces was then understood. They increased the wear of the gear, and were probably abandoned for this reason. The valve spindles were placed at the front and were actuated by a long transverse rocking shaft behind the front buffer beam, as shown in Fig. 14. The cylinders of all these early engines were fitted with end flanges bolted to the front and back plates of the smoke-box. The two cylinders were not directly connected together.

Two 0-4-0 engines by Stephenson (1832) for the Liverpool and Manchester Railway, the "Atlas," and probably the "Milo," were fitted with piston valves having split rings. These were the earliest examples of piston valves.

Rothwell and Hick's 2-2-0 Engine, 1832.—Although inside frames were usually of bars at this early period there were instances of engines with inside sandwich frames only. The four-wheeled engine "Pioneer" (Fig. 16) built in 1832 by Rothwell, Hick and Rothwell, of Bolton, for an American railway, presents an example. It has several features in common with Bury's engines, including the D fire-box, but the important difference lies in the frames. The dimensions of the "Pioneer" were:—Cylinders, 9in. by 14in.; leading wheels, 3ft.; driving wheels, 4ft. 6in.; boiler, fifty tubes, 1½in. diameter. An interesting detail is the variable blast pipe, which had an inverted cone in the orifice. The amount of opening could be con-

⁶ See illustrations in Warren, page 280. Ordinarily, these inside frames were axle supports, but carried no weight.

trolled by the driver. The valve gear was of the single loose eccentric type, but the mechanism for disengaging from the slide valves, when it was necessary to reverse the engine, is not shown. The original drawing from which the illustrations are made was probably sent to America with the engine; it came into the hands of the president of the Richmond, Fredericksburg and Potomac Railroad, who lent it for publication in the *Railroad Gazette*, April, 1901.

Stephenson's Six-wheeled Engines.—The Liverpool and Manchester Railway had been laid with very light fish-bellied rails, 35 lb. to the yard, and it was soon found that the later "Planet" class, weighing 9 tons total with $5\frac{1}{2}$ tons on the driving wheels, was too heavy for the road. Moreover, having four wheels only, with the driving

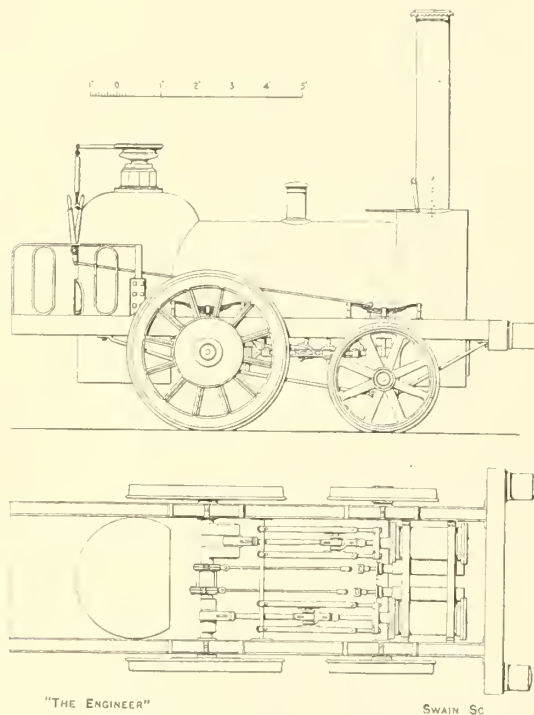

FIG. 16—2-2-0 ENGINE "PIONEER," BUILT BY ROTHWELL, HICK & ROTHWELL, 1832

wheels in front of an overhanging fire-box, they were somewhat unsteady, in spite of the inside cylinders, though much of this unsteadiness might fairly be attributed to the permanent way. Pending the relaying of the latter with heavier rails, it was decided by Stephenson to add a third pair of wheels behind the fire-box. Edward Woods stated that the additional wheels were not intended to relieve the driving wheels of any great part of their load, but to check the pitching of the engine by taking a part of the weight at the time of plunging. The trailing springs therefore carried a very light load. This was the origin of what was formerly termed "Stephenson's patent engine," which ran on six wheels, one pair being

behind the fire-box. The 2-2-2 engine, thus produced, became a standard express passenger engine, and was built in this country from the end of 1833 until 1894. The first new engine of the type, named "Patentee," was built for the Liverpool and Manchester Railway. An engine somewhat similar to the "Harvey Combe" of 1835 but built in 1837, with several improvements, is illustrated by Fig. 17.⁷ A very full description of it is given in Tredgold's "Steam Engine." This description is worth careful study, since it shows in how very few essential details Stephenson's locomotive of 1835 differed from that of to-day; in fact, the principal differences lay in the use of the old fork instead of the link motion, in the absence of sufficient lap on the valves for expansive working, and in the draw-bar attachment to the fire-box. Seeing that only six years had elapsed since the construction of the "Rocket" the progress made in design was truly wonderful. A few of the more important details may be mentioned here. The outside sandwich frames (see plan, Fig. 17) were attached by brackets to the smoke-box, to the middle of the boiler, and to the fire-box. The engine, however, "pulled through the fire-box," the draw links being attached to a channel bracket riveted to the back of the casing. There were two inside plate frames with driving axle guards welded on, and a fifth bearing was provided in a Y centre stay. The cylinders, 12in. by 18in., were encased within the smoke-box and were not attached directly to the frames, a feature already mentioned in connection with the "Planet." The steam chests were separate from, but bolted to, the tops of the cylinders, and all steam joints were made with gasket or canvas covered with red lead and oil. The valve spindles were connected to the valves by means of a rectangular wrought iron frame or buckle dropped over the valve as in present-day practice. The slide valves had $\frac{3}{8}$ in. outside and $\frac{1}{8}$ in. inside lap to ensure that the steam port was completely closed before the opposite steam or the exhaust port was opened. Lead was given to the valve, but there was as yet no real attempt at expansive working. The slide valve in two parts with short straight ports had now been abandoned. The piston rings consisted of one broad outer and a similar inner ring, which were turned exactly to fit the cylinder and each other and cut through in one part, having been first hammered a little all round on the inside to make them press evenly against the cylinder walls. Bent springs of flat steel were placed inside, behind the rings, to regulate the pressure as the latter wore down. The gudgeon pins had spherical journals on which the brasses of the connecting-rod small ends worked, and allowed for any slight deviation from squareness of the connecting-rods. The spherical gudgeon pin bearings reappeared in 1907 on some Midland engines, more than seventy years after their use by Stephenson.

⁷ Sometimes hitherto described incorrectly as the "Harvey Combe." See THE ENGINEER, Sept. 24th, 1926, p. 330.

The crank pins were turned in the same manner as is done to-day, that is, by chucking the axles in cast iron blocks fixed on the ends and having balance weights, the lathe centre pops in the blocks corresponding with the crank pin centres. The crank pins for 12in. by 18in. engines were 5in. diameter by 3in. long, journals $3\frac{1}{2}$ in. diameter by 5in. long, and wheel seats $5\frac{1}{4}$ in. diameter by $7\frac{1}{2}$ in. long. The fore gear excentrics were fixed in the usual position near the middle of the crank axle, but the back gear excentrics were placed between the inside frames and the driving wheels, imme-

considerably from wheels as we now know them. In the engines under consideration the hollow boss and rim were of cast iron. The rim was also made with a hollow groove round it to lessen the weight. The spokes were wrought iron tubes tapering from $2\frac{1}{4}$ in. to 2in. diameter cast into the boss and rim, and arranged so that alternate spokes slanted in opposite directions. The tires of the driving wheels, 5ft. diameter, had a mean thickness of only about $1\frac{1}{8}$ in.; all tires were of wrought iron, welded. The driving tires of Stephenson's engines had no flanges.

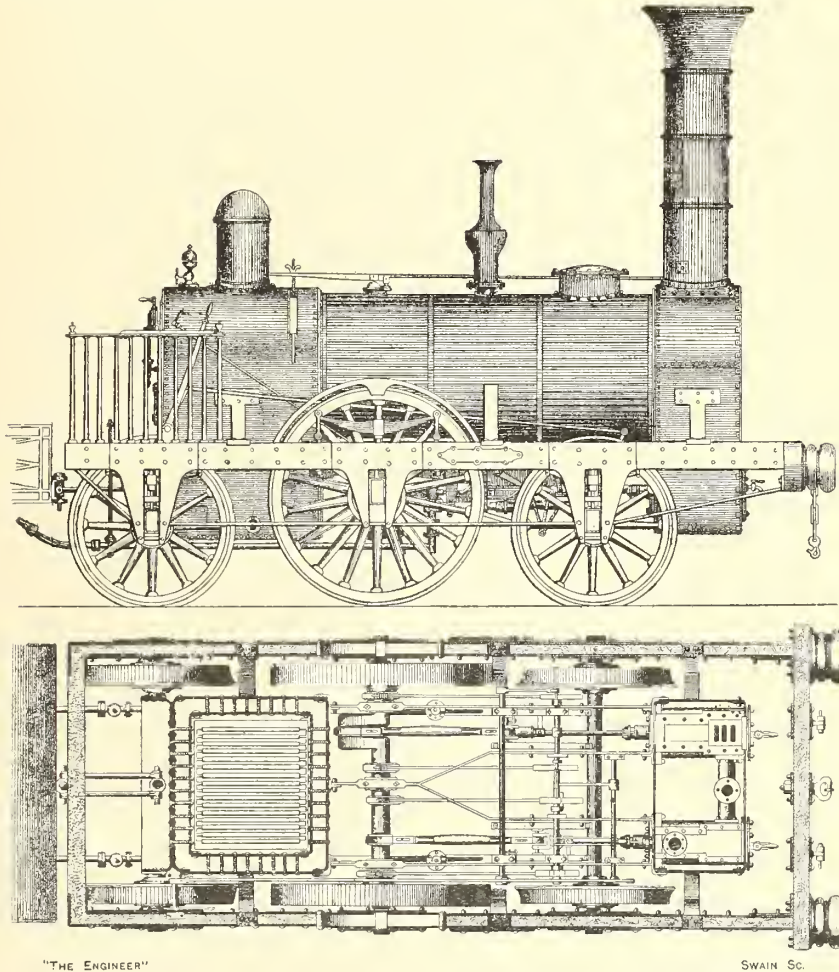

FIG. 17—STEPHENSON'S 2-2-2 PATENT ENGINE OF 1837

diately behind the bosses of the latter. A long transverse rocking shaft, which extended across the engine above the slide bars, actuated the valves. This arrangement of valve gear was used on many of Stephenson's engines until 1841. The separation of the fore and back gear excentrics allowed room for a centre bearing on the crank axle.

It was a long time before the design of wheels settled down to anything approaching uniformity, and Stephenson's wheels at this period differed

The fire-box had water spaces $3\frac{1}{2}$ in. wide at the sides and 4in. wide at the front. The $\frac{7}{16}$ in. copper plates were set in all round the fire-hole to meet the iron casting plates, and the two were riveted together by copper rivets. The pressure was 50 lb. per square inch. The arrangement of side stays was practically what it now is; the $\frac{3}{4}$ in. copper stays were screwed full length and the ends riveted over. They were spaced 4in. apart.

Copper tubes had been found to wear out very quickly owing partly to the effect of hard particles

of coke. Hard brass tubes were suggested by Mr. John Dixon, then of the Liverpool and Manchester Railway, in 1833, and were afterwards used with much better results. These tubes in the engines under consideration were 124 in number and $1\frac{1}{8}$ in. diameter, $\frac{1}{16}$ in. thick. After having been soldered inside at the joint they were drawn through a circular steel die to make them truly cylindrical.

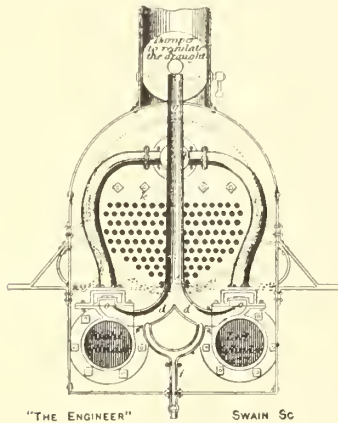

FIG. 18.—STEPHENSON'S 2-2-2 ENGINE EXHAUST PIPE

They were ferruled at both ends with steel ferrules, iron having been found to wear more quickly.

The blast pipe was of copper, $3\frac{3}{4}$ in. diameter at the bottom and tapered gradually to $2\frac{1}{2}$ in. diameter at the orifice. The breeches pipe, which connected the cylinder exhaust flanges with the blast pipe, was provided with a small outlet pipe underneath each of its branches (Fig. 18). These pipes united into a single vertical pipe with outlet at the bottom underneath the cylinders and closed by a cock. Their original object was to drain the water from the breeches pipe. Edward Fletcher fitted similar cocks underneath the steam chests of all the North-Eastern engines, on which they were in use until 1883; but their main object on this railway—at least in the eyes of the drivers—was to reduce the force of the blast by diverting part of the exhaust steam directly into the open air through the exhaust cock instead of through the blast pipe.

In such engines as had no ashpans, and they were the majority, a butterfly damper valve was placed in the bottom of the chimney. The objection to ashpans was due to the custom of dropping the fire at the end of a journey by pulling out the fire bars.

A steam dome on the fire-box was provided, since in the very early engines great difficulty had been experienced in preventing priming. The regulator was of the disc valve type and was placed in the horizontal steam pipe underneath the dome. The disc valve faces were ground to form a steam-tight joint when the valve was closed.

Feed pumps with ball clacks and worked from a direct connection with the piston-rods were used. The ball clacks were the invention of John Melling, of the Liverpool and Manchester Railway, on which they were introduced about 1834. The pumps were provided with pet cocks, which had been invented by George Stephenson.

Goods Engines, 0-4-2 Type.—Just as the 2-2-2 type was evolved from the 2-2-0, so the 0-4-2 type of goods engine was derived from the 0-4-0 by the addition of a pair of trailing wheels. The first two 0-4-2 engines were built by R. Stephenson and Co., for the Leicester and Swannington and the Stanhope and Tyne railways, the former being delivered in December, 1833. These engines, an example of which is shown by Fig. 19, were in great demand on many railways until about 1846. The coupled wheels were generally 4ft. 6in. diameter, though those on the North Midland and the Manchester and Leeds railways had 5ft. wheels, and there were one or two exceptional cases in which 5ft. 6in. wheels were used. The cylinders were 14in. by 18in. The weight in working order of the earlier engines was about 14 tons, but was increased to about $16\frac{1}{2}$ tons in later designs.

Goods Engines, 0-6-0 Type.—The first 0-6-0 engine with inside cylinders was built by R. Stephenson and Co. in February, 1834, for the Leicester and Swannington Railway, and showed a remarkable advance in dimensions, the cylinders being 16in. by 20in., and the coupled wheels 4ft. 6in. The total heating surface, which in the previous 0-4-2 type was 504 square feet, was increased to $656\frac{1}{2}$ square feet, of which the fire-box supplied 67.45 square feet. The boiler pressure does not appear to be known, but nearly all engines of that period worked at 50 lb. per square inch.⁸ The wheel base was 11ft. 7 $\frac{1}{2}$ in. As in the engines previously described, from which this new type was derived, the main framing was outside and of the sandwich type, with additional inside bearings for the driving axle. The fire-box casing was flush with the barrel, and the boiler was 3ft. 11in. in diameter.

Bogie Locomotives.—The first bogie engines built in this country were exported in 1833 to the United States by R. Stephenson and Co. and Tayleur and Co. (now the Vulcan Foundry). The bogie was originally patented by William Chapman in 1812, and was applied to trucks at Newcastle. The eight-wheeled Wylam locomotives of about 1815 are stated to have had one swivelling truck, and the illustration in Nicholas Wood's "Treatise on Railroads" shows one of the trucks with a central pin. A commission of three American engineers visited this country in 1828, and, according to Zerah Colburn, were recommended by R. Stephenson to use a bogie for their loco-

⁸ It may be noted that in the early descriptions of engines by most authors, the boiler pressures were generally omitted. Even D. K. Clark's full descriptions are lacking in this respect.

motives which were intended to negotiate curves of 400ft. radius. The author of "A Century of Locomotive Building," page 305, remarks that "we have no contemporary evidence of this statement." But there does not appear to be any reason for not accepting a statement made by Robert Stephenson himself to Colburn, and the latter, an American engineer, who was always careful in giving due credit to American inventions, throws no doubt upon it. It also appeared

frames, but no pivot is shown. This must be an omission from the old drawing. Messrs. R. Stephenson and Co. built a similar engine for the Saratoga and Schenectady Railroad, and the working drawing shows a pin. The outer crank cheeks of the crank axle were placed against the bosses of the driving wheels.⁹

In considering the general design of the "Fire Fly," it is at once apparent that it includes the main feature of Crampton's subsequent well-known

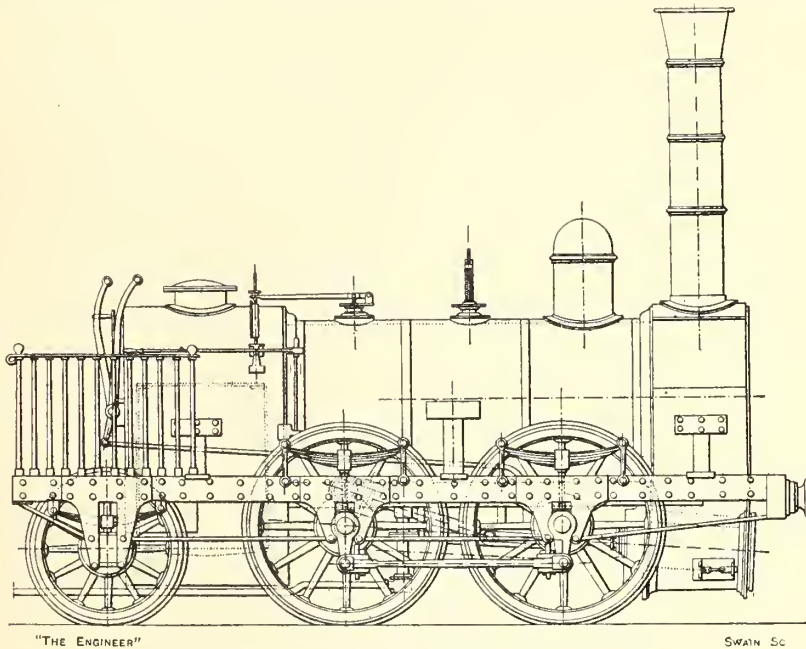

FIG. 19—STEPHENSON'S 0-4-2 PATENT ENGINE, 1833

in *Engineering*, April 3rd, 1868, but the date of the visit of the American engineers is there given as "about 1830." The late Sir Charles Gregory also referred to it in a discussion on "Locomotive Engines for Sharp Curves" (Proc., Inst. C.E., 1863-4, Vol. 23, page 429). The first bogie locomotive in the U.S.A. was constructed by J. B. Jervis in 1832.

Fig. 20 shows one of two 4-2-0 engines built by Tayleur in March and April, 1833, for the Camden and Woodbury Railroad, though, as this line was not opened until 1838, they probably worked for some time on the Camden and Amboy Railroad. The cylinders, 9in. by 14in., were inclined and placed just inside the sandwich frames. The driving wheels, 4ft. 6in. diameter, were behind the fire-box and fixed on an inside cranked axle. The fire-box casing was sufficiently narrow to allow the long connecting-rods to pass between it and the frames. The boiler was only 2ft. 7in. in diameter. Total wheel base, 10ft. 3in. The valve gear is not clearly shown, but was actuated by a single eccentric with a rocking shaft at the back of the driver's platform. The illustration shows one peculiarity in that there is apparently a pair of rollers between the main and bogie

patent with the driving wheels behind the fire-box. Nevertheless, Crampton's design was independently conceived, and it was many years later before he heard of these 4-2-0 engines for America.

Hackworth's Engines with Vertical Cylinders.—The developments down to 1835 recorded above resulted in a type of locomotive which in all essential characteristics and in the majority of its details was similar to the locomotive of the present day. But this type was not at that time universally accepted as the most suitable, and it is necessary to return to the year 1831, and follow the other school of locomotive designers, of whom Timothy Hackworth was the principal and greatest exponent. Naturally, it was chiefly in the North-East of England, more especially on the Stockton and Darlington Railway, where Hackworth's engines were to be found. Their principal characteristics were the continued use of vertical and subse-

⁹ The working drawings of both Stephenson's and Tayleur's engines were probably due to the former firm. A skeleton drawing is given by Warren, page 306. The first practical applications of the bogie have been claimed for Horatio Allen and for J. B. Jervis. See "Memoir of Horatio Allen," by M. N. Forney, pp. 26 *et seq.*

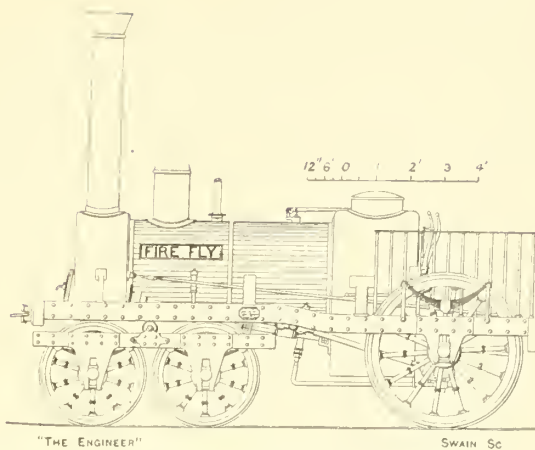

FIG. 20—TAYLEUR'S BOGIE LOCOMOTIVE, CAMDEN AND WOODBURY RAILROAD, U.S.A., 1833

quently of steeply inclined cylinders, and of flue instead of multitubular boilers.

In 1830 Hackworth designed two classes of engine for working the coal traffic of the Stockton and Darlington Railway, in both of which the vertical cylinders and the six-coupled cast iron wheels of the "Royal George" type were retained, but the "motion" and boilers were different. The six engines of the No. 12 or "Majestic" class had the cylinders placed upon an overhanging platform in front of the smoke-box.¹⁰ The piston-rods issued from the bottom ends of the cylinders and the connecting-rods, which were somewhat short, drove a dummy crank shaft with bearings in brackets fixed on extensions

The boiler contained a flue, 9ft. long and 2ft. 6in. diameter, at one end of which the fire-grate was placed; the other end was separated from the boiler by a partition plate with a series of copper tubes, 4ft. long, through which the gases passed to the smoke-box.

In the other six engines of the "Wilberforce" type—Fig. 21—the vertical cylinders and "dummy" crank shaft were placed at the back end. The boilers were also different, and of the combined flue and return multitubular type, which appears to have been intended to combine the advantages of the multitubular boiler with Hackworth's favourite longitudinal flue. The main tube tapered from about 2ft. 4in. diameter at the fire-grate end to about 2ft. diameter at the back, where it entered a D-shaped combustion chamber. From this chamber the gases returned through a number of small copper tubes, fifty-two to seventy in number, to the fire-grate end, at which the chimney was placed on a semi-circular smoke-box. Sections of this type of boiler were given in *The Engineer* of October 31st, 1879, page 322. It had the advantages that it was somewhat cheaper to construct than the ordinary multitubular type, and the whole of the flue, tubes and combustion chamber could easily be removed, and a duplicate set substituted, instead of cutting out a fire-box with its many stays. On the other hand, the single flue restricted the size of the grate, which was placed inside it, so that the boilers had to be unduly forced when the engines were heavily loaded. Though the fuel consumption under these conditions was often heavy, the wear and tear of the boilers was light, and it is probable that

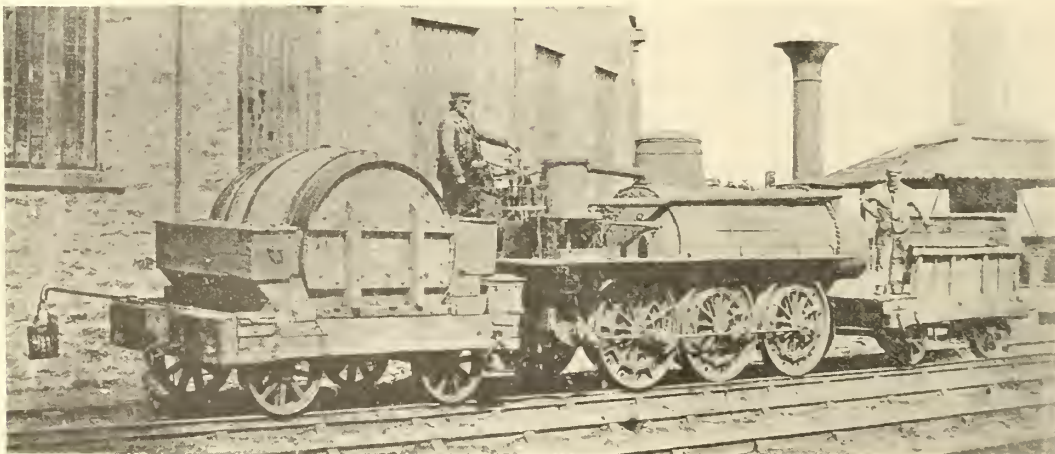

FIG. 21—"WILBERFORCE," STOCKTON AND DARLINGTON RAILWAY, 1831

of the framing. The latter was inside the wheels, and appears to have been formed of a simple bar with pedestals bolted on, though different from that of Bury's engines. The dummy crank shaft was coupled to the first of the six coupled wheels.

¹⁰ The description of these engines has been derived from "Timothy Hackworth and the Locomotive"—Young.

Hackworth had this point and the necessity of keeping the engines in service in view, rather than fuel economy. It is fair to say that these boilers were stated to have given complete satisfaction on the Stockton and Darlington Railway.

All the above engines were put to work in 1831-3. The "Majestic" class had 13in. by

16in. cylinders, the "Wilberforce" class $14\frac{1}{2}$ in. to $14\frac{3}{4}$ in. diameter by 16in. stroke. The cast iron wheels were 4ft. in diameter. The heating surface of the "Wilberforce" class was about 500 square feet, and the pressure 60 lb. For some time Timothy Hackworth clung to the vertical cylinder design, with dummy crank shafts, and built similar but slightly larger engines in 1835-8. The direct drive of the "Royal George" was abandoned, probably for the reason that the driving axle could not be provided satisfactorily with springs. It must be conceded that the vertical cylinders, dummy shaft with its coupling rod, and considerable overhang of the point at which the power was applied, did not form a good mechanical combination, and apparently a counterweight was required at the other end of the engines. But the speed of coal trains on the Stockton and Darlington Railway was rigidly limited to 6 miles per hour, and this fact must be taken into account when criticising the design. In the "Globe" and other passenger engines, with one exception, to be mentioned later, Hackworth employed horizontal cylinders.

outside frames near the middle of the engine, half-way between the driving wheels. The piston-rods issued from the tops of the cylinders, and the connecting-rods drove a dummy cranked shaft of the form of a crank axle for an inside cylinder engine. This had bearings in the outside frames, with outside cranks for the coupling rods. The wheels were inside the frames, and their axles, unlike those of the E. B. Wilson dummy shaft engines of a later date, also had outside cranks.¹¹

The locomotive by J. and C. Carmichael, of Dundee—Fig. 22—was one of those built for the Dundee and Newtyle Railway—4ft. 6in. gauge—of which the first two were put to work in September, 1833, and the third in March, 1834. The vertical cylinders, 11in. by 18in., were placed on the outside framing at the centre of the engine, and the piston-rods, which issued from the tops, were connected through bell-crank levers, as shown. The front or driving wheels were 5ft. in diameter, and the pressure 50 lb. per square inch. The trailing end was carried on a four-wheeled bogie with 3ft. wheels, and these were the first bogies to be fitted to railway locomotives for work

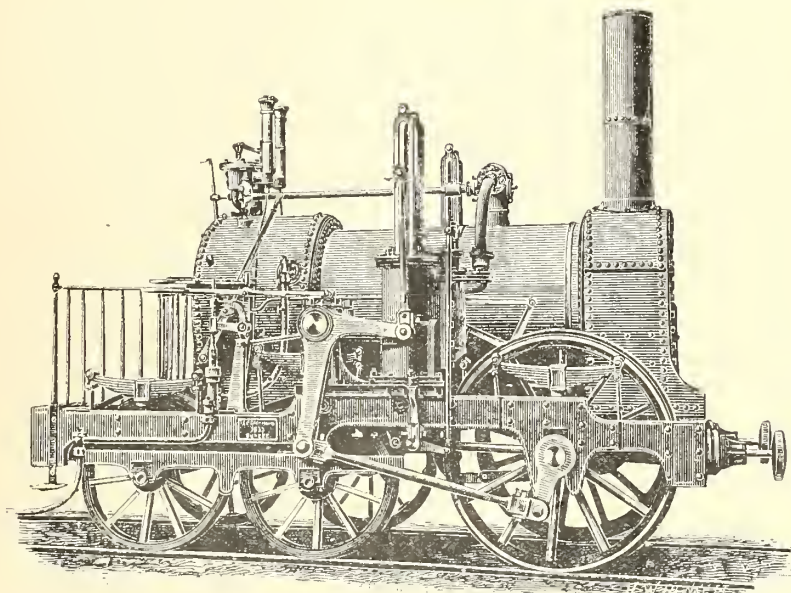

"THE ENGINEER"

SWAIN SC

FIG. 22—J. & C. CARMICHAEL'S DUNDEE AND NEWTYLE RAILWAY ENGINE "EARL OF AIRLIE," 1833

In the case of the return flue and return multi-tubular boilers there was also the disadvantage of having to provide two tenders, one at each end.

Other Locomotives with Vertical Cylinders.—But there were other locomotive manufacturers who did not as yet see the advantages of horizontal or nearly horizontal cylinders. Messrs. Galloway, of Manchester, built an engine for the Liverpool and Manchester Railway in 1832 which had vertical cylinders, 12in. by 16in., and four coupled wheels 5ft. diameter. The cylinders were inverted and supported on pedestals carried by the

in this country. The weight was about 9½ tons in working order, and the engines cost £700. One of these engines, the "Earl of Airlie," was at work until 1850, after which it was used as a pumping engine. The late Alexander Allan had it put into order and photographed.

A vertical cylinder engine on similar principles

¹¹ An illustration of Galloway's engine in its earlier 2-2-0 and later 0-4-0 forms was given in *THE ENGINEER* of July 4th, 1924, by Mr. C. F. Dendy Marshall. The description given above refers to the later alterations to a coupled engine. The illustration in Stretton's "The Locomotive and its Development" is entirely incorrect.

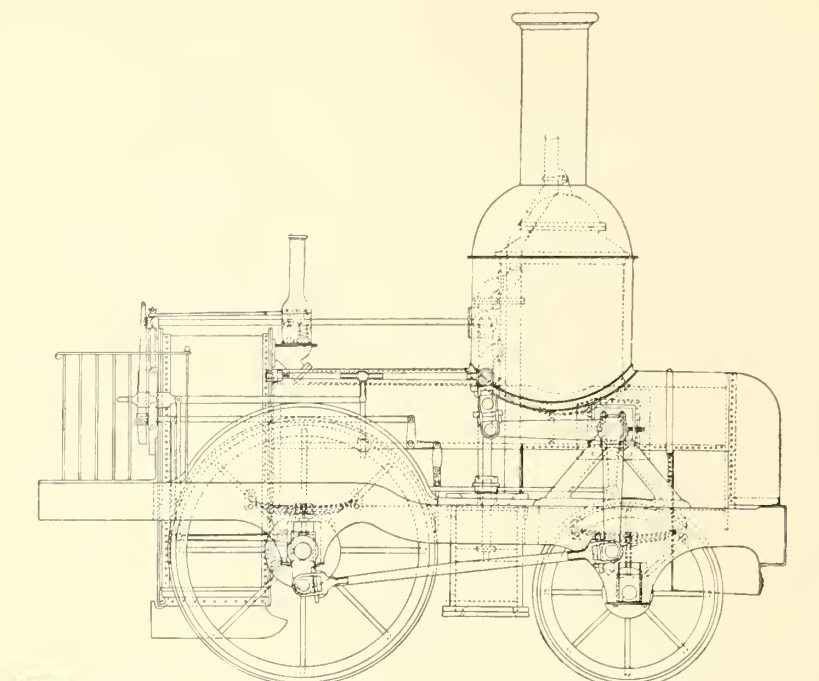

"THE ENGINEER"

SWAIN Sc.

FIG. 22A—SHARP, ROBERTS & CO.'S ENGINE "EXPERIMENT" FOR THE LIVERPOOL & MANCHESTER RLY., 1833

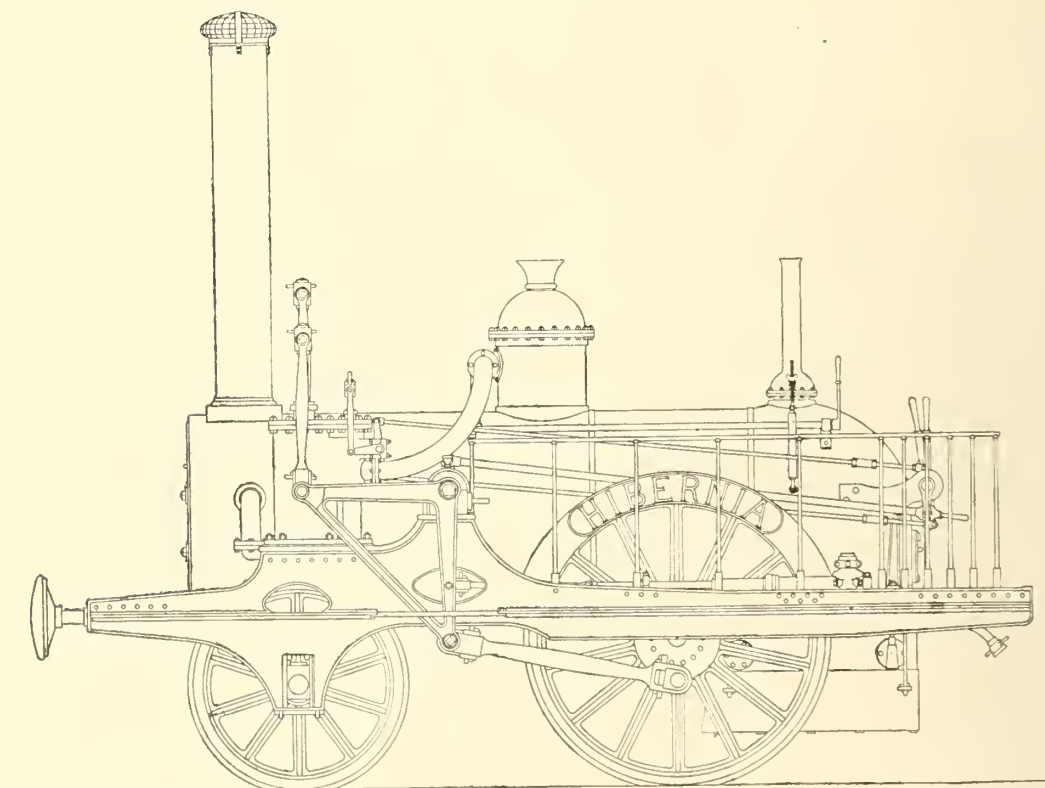

FIG. 23—DUBLIN AND KINGSTOWN RAILWAY ENGINE "HIBERNIA," BY SHARP, ROBERTS & CO., 1834

with bell-crank lever was built by Sharp, Roberts and Co., for the Liverpool and Manchester Railway, in 1833 (Fig. 22A). It was described in *The Engineer*, August 24th, 1923. The same firm, in 1834, built three engines for the Dublin and Kingstown Railway—Fig. 23—in which the vertical cylinders, 11in. by 16in., instead of being situated near the middle of the engine below the platform, were placed just behind the smoke-box and above the leading wheels. A heavy triangular bell-crank was used to connect the piston and connecting-rods. The driving wheels were 5ft. in diameter.

On railways on which passenger trains at fair

from the cylinders. The "Swift" also differed in having inside frames and an outside platform, which helped to support the cylinders.

The cross section of the boiler was like the vertical section of a cottage loaf. It had a single flue straight through to the smoke-box. The valve motion is stated to have been of the gab type with two loose eccentrics. A curious feature was that the weigh-bar shaft is stated to have passed right through the boiler, inside a transverse tube provided for the purpose. All the illustrations appear to show this. At a later date the engine was somewhat modified, when a revolving cowl formed the chimney top.¹² This cowl could be turned

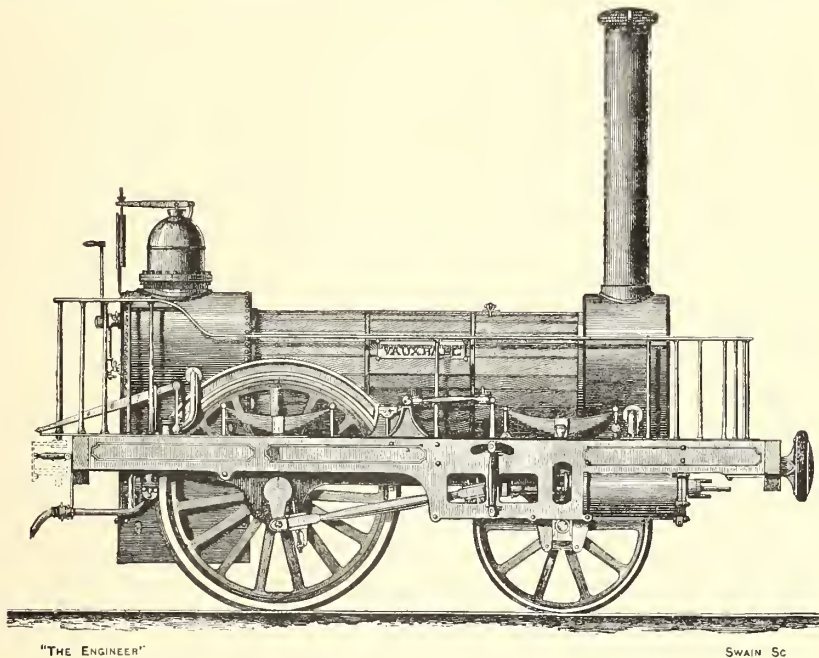

FIG. 24—FORRESTER'S DUBLIN AND KINGSTOWN RAILWAY ENGINE "VAUXHALL," 1834

speeds had to be worked, all these engines proved failures owing to the pitching motion on the springs. The Dublin and Kingstown engines had to be converted to six-wheeled engines, but only slight improvement resulted. The Dundee and Newtyle engines lasted longer; the speeds were slow and the line short, and probably the worst effects of the pitching action were mitigated by the use of the four-wheeled bogie.

Another locomotive with vertical cylinders was the "Swift"—Fig. 25—built for the Stockton and Darlington Railway in 1836, by R. and W. Hawthorn. It was of the 0-4-0 type with 4ft. wheels. The cylinders were placed at the sides of the boiler, and had a direct drive on to an intermediate "dummy" crank shaft carried across the engine under the boiler. The wheel and shaft arrangement was similar in principle to that of Galloway's Liverpool and Manchester engine of 1832, but the latter had a considerably longer wheel base and inverted instead of direct drive

round to suit the direction of the wind. It does not appear to have been definitely stated that Timothy Hackworth designed this engine, but the vertical cylinders and dummy crank shaft seem to be strong evidence of his collaboration, since these features and the flue boiler were not those of Messrs. Hawthorn's usual design, and, moreover, he was entirely responsible for the locomotive power of the Stockton and Darlington Railway.

Forrester's Engines with Outside Horizontal Cylinders.—Other locomotive engineers proceeded on more orthodox lines. Amongst them was George Forrester, of Liverpool, who saw the advantage of horizontal cylinders, but wished to move the machinery from beneath the boiler, and make it more accessible. Forrester's standard engine—Fig. 24—was the first to have *outside* horizontal cylinders. Three of these engines were

¹² See *THE ENGINEER*, June 10th, 1881, page 432. Similar cowls were used on some of G. Stephenson's Killingworth engines.

built for the Dublin and Kingstown Railway, one for the Liverpool and Manchester Railway, all in 1834, and others subsequently for the London and Greenwich Railway. With outside cylinders Forrester combined outside plate frames and bearings, an arrangement which, though at one time very common in South Germany and Austria,

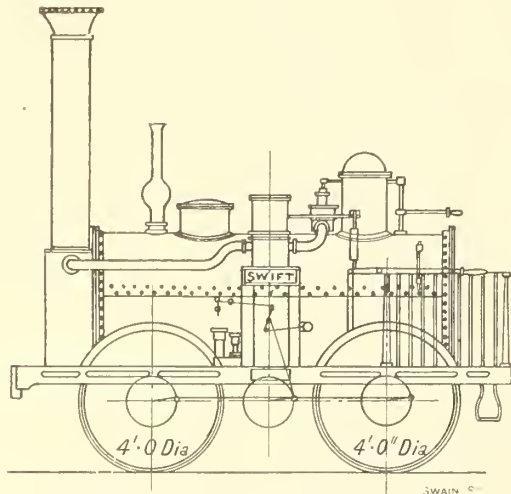

FIG. 25—HAWTHORN'S "SWIFT," STOCKTON AND DARLINGTON RAILWAY, 1836

has not been adopted by British engineers, except for narrow gauge engines. In the case of Forrester's engines it was soon found that the wide spacing of the cylinders caused extreme swaying motion on the road, so much so that they earned the nickname of "boxers." In 1836 an additional trailing axle was placed behind the fire-box to steady them. The valve gear had four fixed eccentrics, and these engines were the earliest to be so fitted. They actuated the valves by four separate gab-end eccentric rods, two for forward and two for back gear. This arrangement removed the constant rocking movement of the starting handles near the driver's position, and allowed better facilities for shunting at stations. A sectional plan of one of these engines, by Alexander Allan, in which the valve gear is shown, appeared in *The Engineer* of March 2nd, 1883. The first three engines of 1834 for the Dublin and Kingstown Railway had no slide bars, a form of swing link parallel motion being used, but the Liverpool and Manchester and subsequent engines had slide bars. The outside frames were of solid wrought iron plates, and the axle guards and frames were solid, and not bolted together. These engines had 5ft. driving wheels, and 11in. by 18in. cylinders.

Here it may be convenient to correct an error in D. K. Clark's "Locomotive Machinery," page 10, Fig. 11, which also appears in Colburn's work, page 41, Fig. 42. These illustrations show a Forrester six-wheeled engine, with slide bars outside the outside frames, and a different valve gear with vertical eccentric rods. But they do not, as was stated, represent the 1834 design; the latter

was the four-wheeled engine described above. The valve gear with vertical rods—D. K. Clark, Figs. 11 and 25—was applied in 1840 to two six-wheeled engines for the Grand Junction Railway, and it may have been used on four similar engines built in 1838 by the same firm for the Birmingham and Gloucester Railway. All these engines had some points in common with Clark's Fig. 11, but their driving wheels were 5ft. 6in. diameter. Alexander Allan, who was with Forrester until 1840, in a private letter in the possession of the writer, found fault with Clark's illustration for the reason that the cylinders of all Forrester's engines until that date were fixed between the outer and inner frames, as in Fig. 24, but not attached outside the outer frames, and that all had four and not two slide bars. Further, the trailing wheels, 3ft. diameter, of Forrester's engines were always smaller than the leading wheels, which had a diameter of 3ft. 6in. The cylinders of these later engines were 13in. by 18in. None of Forrester's outside framed engines, with outside cylinders, were built for this country after 1840.

The valve gear referred to above was actuated by one fixed eccentric on each side, instead of the four eccentrics used in the earlier engines. The eccentric rods were shortened and the levers lengthened to obtain a greater angle of movement. Fuller particulars are given in D. K. Clark, page 21.

Hawthorn's "Comet."—The use of four fixed eccentrics was also adopted by R. and W. Hawthorn, independently of Forrester's design, in the 0-4-0 engine "Comet," which started work in

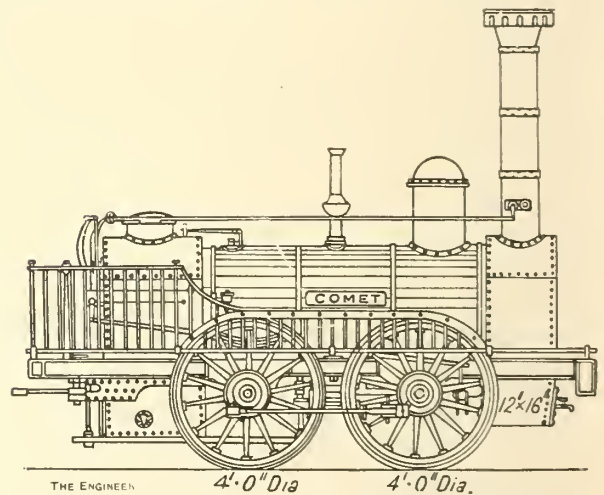

FIG. 26—HAWTHORN'S ENGINE "COMET," NEWCASTLE AND CARLISLE RAILWAY, 1835

March, 1835, on the Newcastle and Carlisle Railway. This engine had inside cylinders and inside plate frames, with axle guards bolted on. The cylinders, 12in. by 16in., were inclined slightly upwards, and the piston-rods passed underneath the leading axle. The wheels had a diameter of 4ft.: the "Comet" was an engine of what may be

termed orthodox design, and was the forerunner of a considerable number of similar engines. It is illustrated by Fig. 26.

Hawthorn's "Planet" Type Locomotives.—Considerable interest attaches to the Stockton and Darlington engine "Sunbeam"—Fig. 27—by R. and W. Hawthorn, 1837, in that although the design was on the lines of Stephenson's "Planet" the engine was purchased by the railway of which Timothy Hackworth then had the contract for locomotive power. The driving wheels were 5ft. in diameter, and the cylinders 12in. by 18in. The leading wheels were 4ft. diameter. Weight in working order 9 tons 13 cwt., and empty 8 tons 11 cwt.

The "Sunbeam" does not appear to have been built for the Stockton and Darlington Railway, but was one of four engines intended for the New York, Boston and Providence Railway, U.S.A., of which only one appears to have been sent to

tion of Fuel and the Evaporation of Water," in Tredgold's "Steam Engine") stated that their use coincided with an extravagant increase in coke consumption, but added that it was erroneously attributed to the mechanical disadvantage of the short stroke. The slide valves on the Liverpool and Manchester Railway at this time had no lap, and the steam was not worked expansively. The engines were certainly not a success; the short stroke was abandoned and no more were built. Robert Stephenson ("Proc.," Inst. C.E., 1849) stated that these engines consumed too much water.

Timothy Hackworth also tried the short stroke engine. The "Arrow," built for the Stockton and Darlington Railway in 1837, at his works at Shildon, had 9in. piston stroke only. The late Joseph Tomlinson gave the diameter of the cylinders as 17in., but another, though probably incorrect, official record stated 21in. The "Arrow"

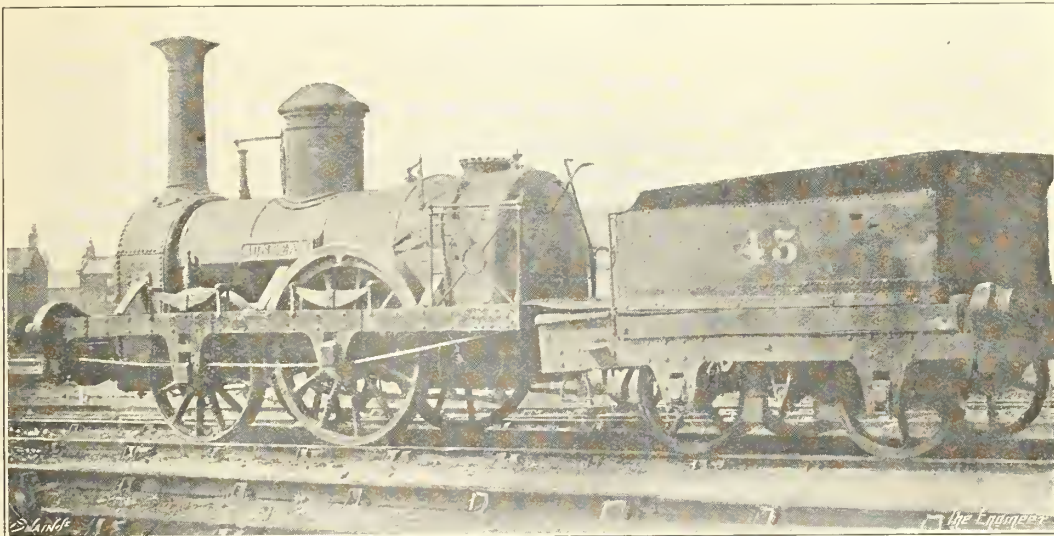

FIG. 27.—HAWTHORN'S STOCKTON AND DARLINGTON RAILWAY ENGINE "SUNBEAM," 1837

America. The two others went to the Paris and Versailles Railway. Two smaller "Planet" type engines by Stephenson had been purchased previously in 1831 by the Stockton and Darlington Railway.

"Short Stroke" Locomotives.—In 1836 the locomotive department of the Liverpool and Manchester Railway considered that, in view of the increased speed of passenger trains, it might be desirable to reduce the piston velocity by shortening the stroke. Eleven passenger engines of the standard 2-2-2 type were built by Tayleur, R. and W. Hawthorn, and Mather, Dixon and Co., with cylinders 14in. diameter by 12in. stroke, instead of the 12½in. by 16in. and 12in. by 18in. cylinders which were then generally used. There does not appear to be any record of the actual performances of these engines in their original condition. Edward Woods ("Observations on the Consump-

tion of Fuel and the Evaporation of Water," in Tredgold's "Steam Engine") stated that their use coincided with an extravagant increase in coke consumption, but added that it was erroneously attributed to the mechanical disadvantage of the short stroke. The slide valves on the Liverpool and Manchester Railway at this time had no lap, and the steam was not worked expansively. The engines were certainly not a success; the short stroke was abandoned and no more were built. Robert Stephenson ("Proc.," Inst. C.E., 1849) stated that these engines consumed too much water.

Timothy Hackworth also tried the short stroke engine. The "Arrow," built for the Stockton and Darlington Railway in 1837, at his works at Shildon, had 9in. piston stroke only. The late Joseph Tomlinson gave the diameter of the cylinders as 17in., but another, though probably incorrect, official record stated 21in. The "Arrow"

¹³ "Timothy Hackworth and the Locomotive," by Robert Young, M.I. Mech. E., pp. 274-276.

that this was not Hackworth's design, but a subsequent alteration, J. W. Hackworth not only ascribed it to his father, but added that the latter considered the arrangement likely to be used to a greater extent.¹⁴

Tomlinson further adds that the "Arrow" was provided with a cross shaft on which there were two solid cast iron friction wheels. By means of levers, the latter could be pulled down between the driving and trailing wheels, thus converting a

"single" engine into the equivalent of a coupled engine. It is doubtful whether the "Arrow," which was put to work in May, 1837, had this arrangement when new, for the patent was that of John Melling, locomotive superintendent of the Liverpool and Manchester Railway, to whom it was granted in July, 1837. It is of interest to note that F. W. Webb applied a similar friction wheel coupling to a London and North-Western passenger engine¹⁵ about sixty years later.

¹⁴ "A Chapter in the History of Locomotion," page 19. J. Tomlinson described it as the idea of a draper in Darlington.

¹⁵ The L. and N.W.R. 2-4-0 engine had the coupling-rods removed, and friction gear substituted. It was illustrated in the LOCOMOTIVE MAGAZINE, Vol. IX. (1903), page 350.

Chapter IV — 1837-41

IN dealing with this period, it is proposed to follow the development of the standard gauge engines of the Hackworth, Bury, and Stephenson schools, and also give some account of the broad-gauge engines of the Great Western Railway, the first section of which was opened in 1838. The narrative will be rendered more intelligible by dealing with each of the locomotives separately without regard to chronological order.

Hackworth's Mineral Engines, with Inclined Cylinders.—In 1838 Hackworth abandoned vertical cylinders and "dummy" crank shafts for his 0-6-0 mineral engines, and reverted to the direct drive of the "Royal George," but placed the cylinders at the back end of the boiler, to which they were attached in a position inclined at about 30 deg. The connecting-rods worked

worth for the Stockton and Darlington Railway, though his influence was apparent in some of the later engines of the company, which will be mentioned subsequently.

It may be asked why Hackworth, having seen the advantages of horizontal cylinders for passenger engines, did not use them for his mineral engines. In 1838 the only engines with outside horizontal cylinders were the passenger engines by Forrester, with their awkward outside frames, a type which no other designer in this country desired to perpetuate. Two inside framed 0-4-2 engines, to be mentioned subsequently, were built in 1839 for the London and Croydon Railway, and they appear to have been the first definitely known to have combined outside horizontal cylinders, with coupling-rods on the leading wheels.

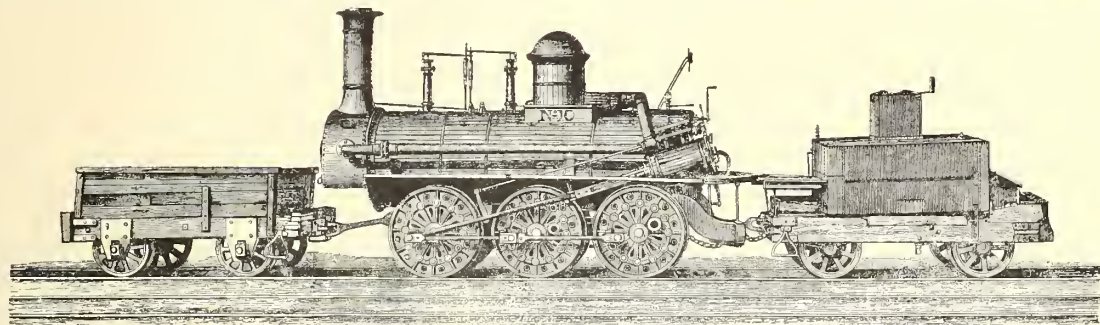

THE FIGURE.

SWAIN Sc

FIG. 28.—T. HACKWORTH'S 0-6-0 ENGINE FOR THE STOCKTON AND DARLINGTON RAILWAY, 1838

on crank pins in the front wheels at the chimney end of the engine. The illustration—Fig. 28—shows one of this class for the Stockton and Darlington Railway, which had 4ft. wheels, 9ft. wheel base, and 14in. by 18in. cylinders. Some of the earlier engines of the class had cylinders 12½in. diameter, and in later engines of 1842, 14½in. by 20in. The boilers, in which the pressure was increased to 70 lb., were of the "outward" flue and return multitubular type previously described.

It seems likely that Hackworth's reason for introducing this design was to have an engine with springs for each axle, and at the same time do away with the awkward vertical cylinder drive of the "Wilberforce" class. But in making the change he merely reverted to Stephenson's old type of 1828, as exemplified by the "Lancashire Witch." A considerable number of these engines were designed by Hackworth for the Stockton and Darlington Railway, and were built, not only by him at Shildon, but also by the two Darlington firms of W. and A. Kitching and William Lister. They were the last designed by Timothy Hack-

Had Hackworth adopted a similar design with six coupled wheels, he would have had to alter completely the design of the framing of his engines. But he was not alone in discarding the idea, if he ever considered it, for it is a remarkable fact that British locomotive engineers have always avoided the outside cylinder 0-6-0 tender engine, universal on the European continental railways, and less than fifty, all told, have ever existed on British railways throughout their history.

Bury's Bar-framed Locomotives.—The general design of Bury's engines remained as before, with improvements in details, and only four-wheeled engines were built. The type was also taken up by Braithwaite and Milner, of London, who built a number for the Eastern Counties Railway and American railways. Although it adopted most of the features of Bury's design, the London firm generally used round-topped ordinary type fire-boxes, surmounted by domes, and discarded Bury's D-shaped pattern.

For a number of years Bury used iron for fire-boxes. The D-shaped fire-boxes were welded at the front corners up to a level with the bottom

row of tubes. He eventually used copper, but the writer can find no record of the date of this change, though it was certainly some time after Stephenson had discarded iron for copper in 1832. In 1837 Edward Bury took charge of the locomotive department of the London and Birmingham Railway, and immediately introduced his four-wheeled type of engine. By the end of 1841 there were 58 passenger engines of the 2-2-0 type—Fig. 29—and thirty goods engines of the 0-4-0 type on that railway. Other lines, such as the Manchester and Bolton, North Union, and Midland Counties railways, adopted the four-wheeled type practically exclusively, and the Edinburgh and Glasgow Railway and other lines had a large number. On the other hand, the Liverpool and Manchester

trailing end, he advocated small fire-boxes, and, short as these were, the heating surface was still further reduced by their semi-circular D shape. He also tried to minimise the danger in case one of the two axles broke, and in his evidence before the Gauge Commissioners in 1845 stated that on the London and Birmingham Railway there had been no case of an engine so far crippled by a broken crank axle that it could not get home; in fact, some of them had taken their trains on in spite of the broken axle. He admitted that one engine had left the rails owing to the breakage of a leading axle. But nothing appears to have been said on the subject of a bad accident in 1841 on the Brighton line and another in France, in which Bury's engines left the rails. It should also be

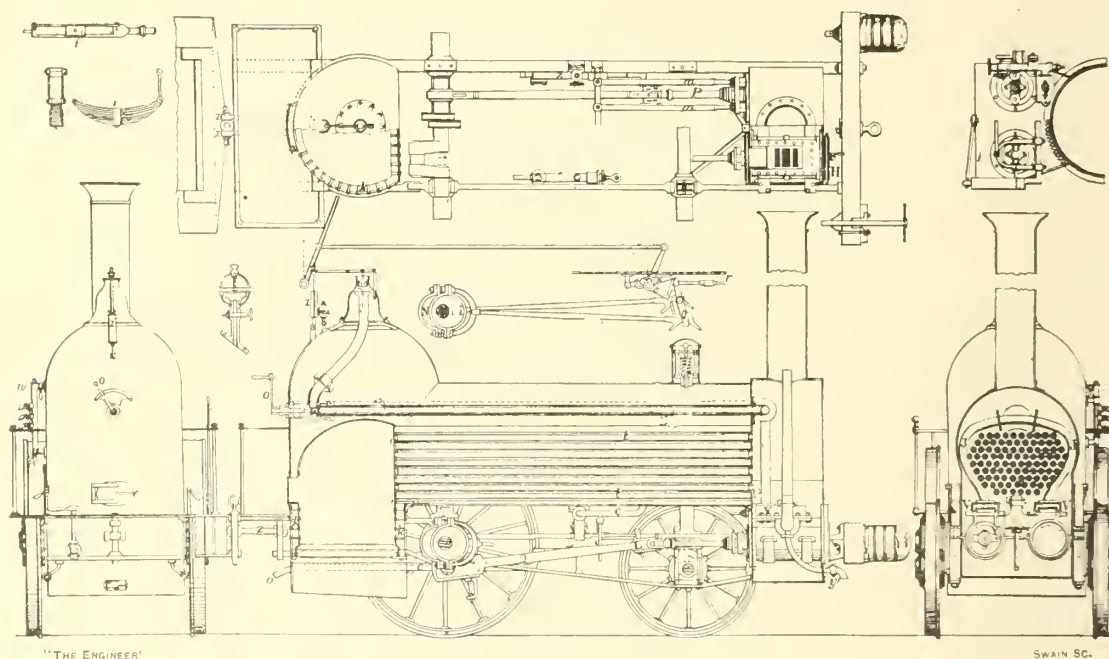

FIG. 29—SECTIONS OF BURY'S 2-2-0 PASSENGER ENGINE, 1837

Railway, after experience with four-wheeled engines, had converted most of them to six-wheeled, and other important main lines, such as the Grand Junction, North Midland, &c., would not even look at the four-wheeled type. There resulted for a time a "battle of the wheels," and the circular issued by Bury, Curtis and Kennedy—referred to previously—had for its main object the putting forward of arguments in favour of the four-wheeled engine. Bury contended that it cost less, and the total weight being smaller, less power was required to take it up the inclines. It was safer and not so liable to leave the rails on curves; there were fewer parts and consequently less friction and less liability to break down. His best argument was based on the smaller size of turntables and engine sheds required. There were two arguments in which Bury certainly went astray. In order to reduce the overhang at the

added that Bury tried to minimise the unsteadiness of his four-wheeled engines by coupling the tender as rigidly as possible to the engine. The four-wheeled engine was too small, and it was not unusual on the London and Birmingham line to work the goods trains with four of Bury's engines attached, and he admitted before the Gauge Commissioners that on one occasion no less than seven engines were required during a heavy gale, for a train of forty-five wagons.

In 1845 Bury bowed to the inevitable and began to build six-wheeled engines. It was not the general design, other than the use of inside frames, which had pulled his four-wheeled engine through for so long, but the undoubted excellence of the workmanship which his firm put into the engines.

The 2-2-2 Passenger Engine.—The Stephenson 2-2-2 type with inside cylinders and outside

sandwich frames had proved itself to be an efficient machine, and was, in effect, a "survival of the fittest." During the period 1837 to 1841 various locomotive builders added their own ideas, and the details of the engines began to exhibit the individualities of the various firms. For the purpose of contrasting these types, the six illustrations—Figs. 30 to 35—are given. The first figure represents the North Midland mail engine, which was built from R. Stephenson's drawings

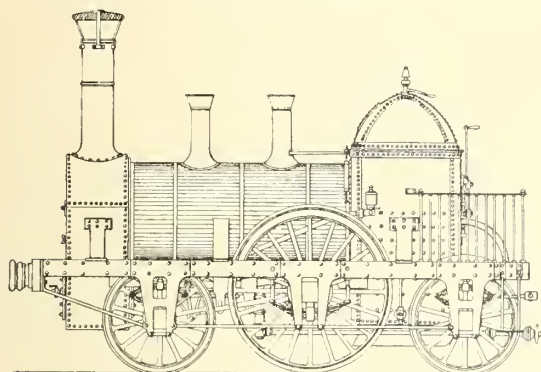

FIG. 30—STEPHENSON TYPE 2-2-2 ENGINE

by various firms. All the examples have some general features in common. The cylinders in most cases were 13in. by 18in., and the driving wheels 5ft. 6in. During 1840-1 many were built with 14in. by 18in. cylinders for heavier traffic and steeper gradients. Such were the North Midland "Mail" engines—Fig. 30—which had 6ft. driving wheels. The heating surfaces varied somewhat, but the mean was about 500 to 550 square feet for the tubes and 50 to 55 square feet for the fire-boxes. The average boiler pressure was about 60 lb., but was raised to 70 lb. in some of the later engines of 1841-2. The framing was on the principle of Stephenson's engine "Harvey Combe," previously described, the smoke-box and boiler being secured by brackets to and supported by the outside sandwich frames, but the inside frames extended only from the back of the smoke-box to the front of the fire-box. The driving axle had at least four bearings and frequently five or even six.

One of the early difficulties met with was water in the cylinders, owing either to direct "priming" or to leakage into the internal steam pipe through the joints. Measurements made in France on locomotives by British makers of the 1834-1840 period showed that in the earlier engines the total boiler content was about 55 cubic feet, of which the steam space occupied about 18.6 cubic feet. In the later engines of 1839-40 the boiler content had—according to Flachet and Petiet—increased to about 81½ cubic feet, and the steam space to 23 cubic feet. The want of sufficient steam space in the earlier engines caused priming, and this accounts for the variety of domes and steam

chambers in the illustrations. Messrs. Stephenson—Fig. 30—did away with the steam dome on the barrel in 1840 and made the fire-box casing with a vaulted roof, as Bury had already done for some years with his smaller fire-boxes. This type was constructed by Stephenson, Kitson, and other makers for about eight years, and it was also adopted by Gooch on the Great Western Railway. The top of the casing was of a somewhat pointed pyramidal shape, owing to the way in which the side and end sheets were cut and brought together, and gave rise to the term "Gothic" fire-boxes. Bury's fire-box casings had rounded corners, and were either hemispherical or slightly flattened on the top, the latter type being known as "haystacks." The two were frequently confounded. A large number of hemispherical fire-box casings were also made by Stephenson from 1842 onwards; they required less staying than the Gothic pattern, in which the surfaces of the dome were flatter.

Taylor and Co.—Fig. 31—and Mather, Dixon and Co.—Fig. 32—increased the steam space in another way by providing two domes. The one above the fire-box was merely a steam vessel, the other near the chimney contained the regulator. This was also the practice on the Liverpool and Manchester Railway. Rothwell and Co.—Fig. 34—and Sharp Roberts—Fig. 35—contented themselves with raising the fire-box casing and providing a tall dome behind the chimney. A 2-2-2 engine by G. and J. Rennie (London)—illustrated in *The Engineer*, April 8th, 1921, page 367, in elevation and section—is another example of this practice. The forward position of the dome was supposed to have as its principal object the placing of the regulator as far as possible from the fire-box where the most violent ebullition took place, but there were other equally cogent considerations. Long steam pipes were

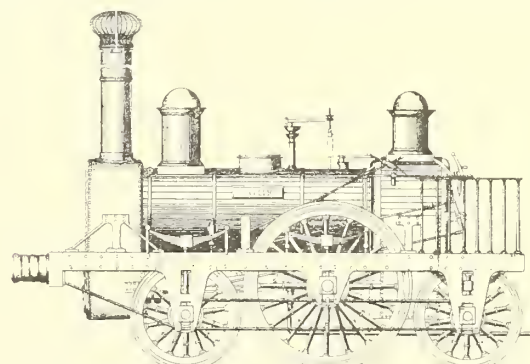

FIG. 31—TAYLEUR & CO. TYPE 2-2-2 ENGINE

then made with joints and glands, which caused leakage when the water level was high, and, to avoid this trouble, the pipes in the designs under consideration were made as short as possible. Moreover, with the short steam pipe, the steam space in the boiler was not occupied. On the other

hand, when the dome was situated in front, it had the disadvantage of throwing some extra weight on the leading wheels, and in the old 2-2-2 type the trailing pair was, if anything, too lightly loaded. Messrs. Hawthorn—Fig. 33—compromised by placing the dome on the middle of the barrel, a position to which they had consistently adhered. W. and A. Kitching's 2-2-2 engine,

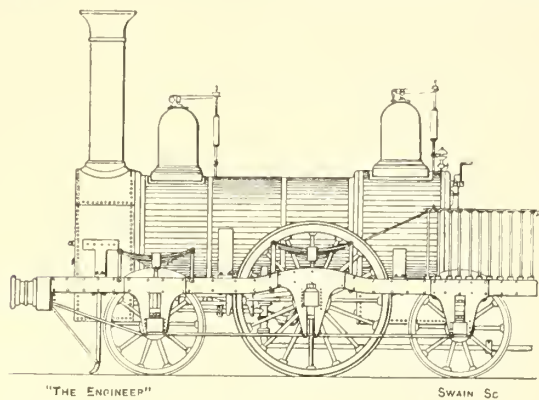

FIG. 32—MATHER, DIXON & CO. TYPE 2-2-2 ENGINE

“Raby Castle,” for the Stockton and Darlington Railway—Fig. 36—was similar.

Boilers.—Owing to the small sizes of plates, a large number were required for the boilers. Warren records that a “Planet” type boiler in 1831 then required no less than twenty-two plates. According to a specification for new boilers for the Liverpool and Manchester Railway, dated October, 1838, the barrels were to be made of four narrow Low Moor iron plates, each the full length of the barrel, that is, about 7ft. 6in. to 8ft. The plates were lap jointed with longitudinal seams only. Thus the material worked under the worst conditions, for not only were there four longitudinal lap seams in boilers such as were specified by the Liverpool and Manchester Railway, but the grain of the iron was placed so that the maximum stress acted across it. For 50 lb.

pressure, $\frac{1}{8}$ in. plates were usual, but the front tube plate was $\frac{3}{8}$ in. thick. Rivet holes were punched, but care was taken that the plates were assembled so that the smaller diameters of the holes were inside the joint. The writer has not been able to find any record of rimering out rivet holes at this period. The tubes were usually of brass, but iron had been used. John Hawkshaw used iron fire-boxes and iron tubes on the Manchester and Bolton Railway, but had trouble with the fire-boxes.

Boiler clothing may be briefly mentioned here. Until about 1838-9 it was usual to clothe the barrel with strips of wood lagging, but the fire-box casing was generally left bare. From that date several firms began to clothe the lower part only of the casings, also with wood battens, though the engines by Mather, Dixon and Sharp, Roberts—Figs. 32 and 35—of 1839 show completely clothed fire-boxes. Stephenson's engine—Fig. 30—is shown without clothing on the casing, as in the original drawing, but it is not certain whether the latter was a conventional drawing-office method of showing the fire-box, and it is possible that in 1840 the lower portion at least was lagged, as in the Great Western engines then built by the same firm.

The wooden battens were tenoned and grooved, and finished by being stained and varnished. Subsequently, a layer of felt was placed beneath them, but the experience of several years proved that rain got between the joints and damped the felt, so that about 1847 sheet iron covering began to replace the wood. E. B. Wilson and Co. continued the use of polished mahogany battens until about 1851.

Fire-box Roof Stays.—In some of the very early engines of 1830-1 the roof stays consisted merely of four short angle iron stiffeners, secured to the middle portion of the fire-box crown, without extending to the tube and back plates. In 1835 Messrs. Stephenson substituted iron girders for the angle bars. These girders had projections at intervals which rested upon the roof, but they still remained shorter than the full

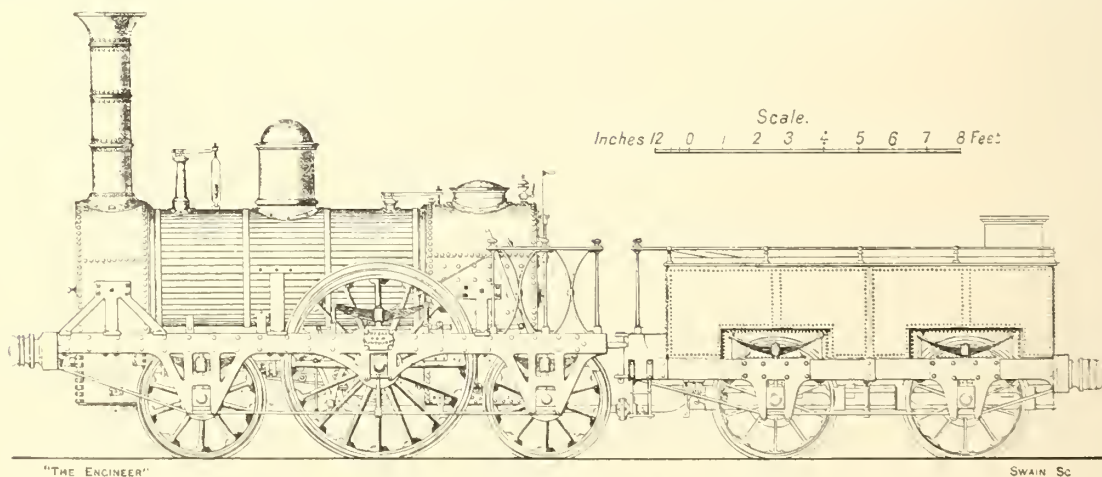

FIG. 33—HAWTHORN TYPE 2-2-2 ENGINE

length of the box. Some of Bury's earliest engines of 1831-3 had dome-shaped spherical crowns without any roof stays; but when he introduced the D-shaped fire-box in order to increase the heating surface, the front half of the dome was flattened, and to strengthen it four small girders were used, the back ends of which simply rested on the curved back portion of the roof without other support.

Stephenson's North Midland engines of 1840, illustrated by Warren, had girders extending over the laps of the tube and back plates, though they did not take a bearing on the vertical sides. Some makers neglected to make the girders long enough, and when the roof gave way, as actually happened in the case of certain explosions, the girders were forced bodily through the fire-box. This also occurred in the case of a Bury fire-box provided with the short girders described above.

Side stays for some years were of iron, screwed through both plates. Warren states that they were riveted over outside the casing, but had nuts inside the fire-box. W. P. Marshall, in his description in Tredgold's "Steam Engine," of Stephenson's 2-2-2 engine of 1835-6, states that $\frac{3}{4}$ in. screwed copper stays were then used, riveted over outside both plates.

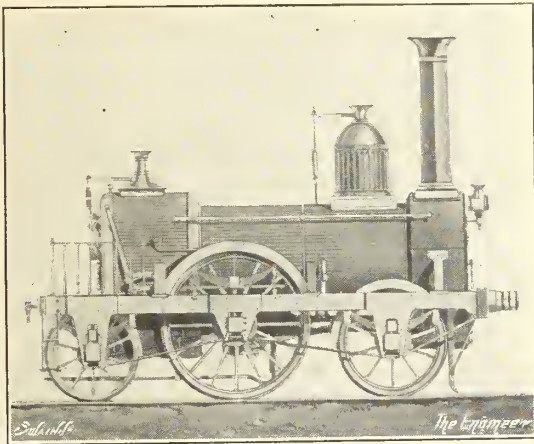

FIG. 34—ROTHWELL TYPE 2-2-2 ENGINE

Boiler Fittings.—The boiler fittings and accessories differed from what they now are. There were the usual water level gauges with shut-off cocks, wash-out holes, blow-off cock, and fusible plugs. In most cases there was a lock-up safety valve, spring loaded, and arranged to blow off at a pressure slightly greater than the working pressure, which was regulated by the spring-balance safety valve. These details are mentioned to show the great progress made during the few years that locomotives had been in existence. There was, of course, no dial pressure gauge, and the driver had to depend upon the "feel" of his spring balance, which in some cases was inconveniently placed on the middle of the boiler.

In such of Stephenson's engines as had the

dome over the fire-box, the steam-pipe was in one length from the smoke-box to an enlarged regulator chamber underneath the dome, and the pipe entered this chamber through a gland which allowed for expansion. Bury used a similar pipe, with a flanged joint, for the regulator chamber, but no gland. Fenton, Murray and Jackson, in their earlier engines, made the steam pipe in flanged lengths, but with allowance for expansion at the front end, where the two copper pipes to the cylinders branched off from bends attached to the main pipe inside the barrel, each branch passing independently through the smoke-box tube plate.

The greatest difference lay in the regulators, of which there were many varieties. The slide valve gridiron regulator in the dome was then unknown, but it is not certain whether some firm—unknown to the writer—did not try a slide valve regulator in the smoke-box. Most of the regulators then in use were of the rotating disc valve type, with two sector-shaped apertures, which, when open coincided with similar openings in a facing on the steam pipe chamber. R. Stephenson and Co. were amongst the first, if not actually the first, to use this type, and it appears in their engines of 1835. Tayleur used a more complicated regulator on the same principle, but placed it in the smoke-box, whereas in many of Stephenson's engines it was at the fire-box end of the steam pipe. Fenton, Murray and Jackson in 1839 used a double beat valve, which was placed in the vertical steam pipe immediately under the dome. The movable portion of the valve was attached to a frame, which was lifted by a tappet attached to the regulator spindle. It was probably one of the best regulators of that day, and certainly the easiest to open, but it was difficult to keep steam tight, though in this respect the disc valves were very far from perfect.

Bury, judging from the number of designs which he introduced and almost as quickly discarded, seems to have had considerable trouble with his regulators. In his early engines he fitted the T pipe joining the main steam pipe and the vertical pipe from the domed fire-box casing with an ordinary conical plug cock attached to the regulator spindle. There was excessive friction, and as the plug expanded it frequently would not open when closed, or close when opened. The driver was supposed to grease it in the shed by removing the spindle gland. Bury's next and improved regulator was extremely ingenious as a mechanical contrivance, but still more unpractical. The regulator spindle was fitted with a long collar, which rotated inside a box. The latter had two pins let into it, which engaged in a spiral groove cut in the circumference of the collar, so that as the spindle and collar were rotated by the regulator handle the box and mitre valve attached to the latter received a longitudinal movement and opened the valve. The arrangement required cleaning and lubricating very frequently, to do which a man had to enter the boiler. Moreover,

since it had a tendency to shut automatically, the driver had to keep his hand on the regulator handle.

A third design, illustrated by D. K. Clark, page 223, consisted of a horizontal double-beat valve actuated by a double-threaded screw.

Before 1840 Sharp, Roberts & Co. improved the Stephenson disc regulator by placing it in the dome, and actuating it by a double lever and vertical links. This type was used for many years. This regulator has always been credited to Sharp, Roberts, but Rothwell's engines of 1838 for the London and Southampton Railway were fitted with it. It may be that Rothwell used Sharp's design, which in that case was made before 1838.

Frames.—The shape of the outside framing of Sharp, Roberts' engine—Fig. 35—differs from most of the other designs, and was adopted to

boiler from lifting—see "A Story of Railway Pioneers," by Major Snell.

The Stephenson engines—Fig. 30—had underhung driving springs, as in the "Planet," but the leading and trailing springs were of the double elliptical form, which for a few years was extensively used by R. Stephenson and Co., but afterwards disappeared for a long time from British practice.

Motion Details.—The Stephenson pistons have already been described in Chapter II., and metallic rings had superseded the old hemp packings. Another form of piston by Fenton, Murray and Jackson had a wide groove turned in the periphery, in which two brass rings were placed side by side. These rings were cut in two and the abutting ends were bevelled. As the rings wore down, wedges were forced from the inside into

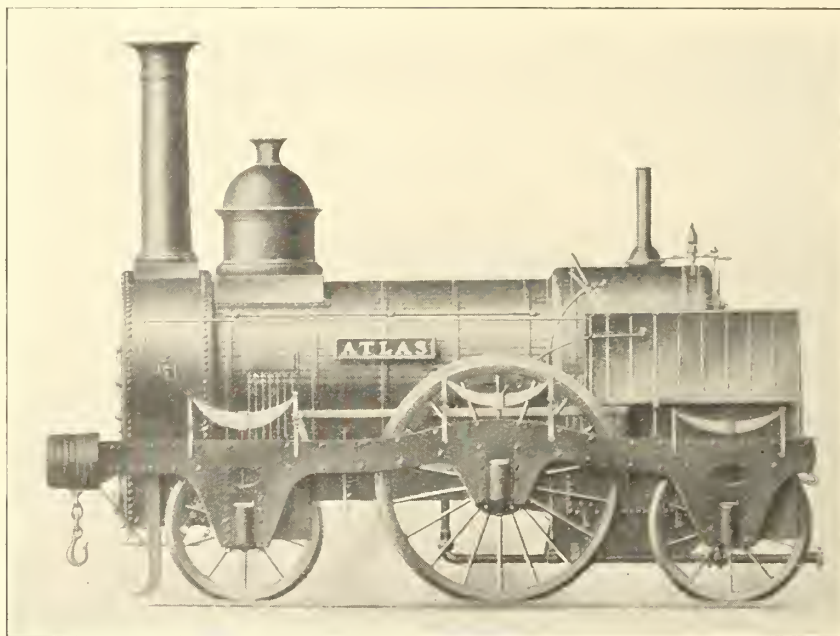

FIG. 35—SHARP, ROBERTS TYPE 2-2-2 ENGINE

avoid the deep hornplates for the carrying axles necessary when the top of the frame is horizontal. The latter had a tendency to spring laterally. Sharp's design, which first appeared in 1837, was afterwards copied by nearly all other manufacturers, and a similar one is seen in Mather, Dixon's engine—Fig. 32—with the difference that Sharp, Roberts welded the axle guard plates to the body of the frame, whereas Mather, Dixon and others bolted them on. But all the designs show the defect of binding the boiler too rigidly to the frames.

In 1839 Isaac Dodds, locomotive superintendent of the Sheffield and Rotherham Railway, fastened his boiler at the smoke-box end only, and allowed it to slide on the frame at the back. A small plate or bracket bolted to the frame prevented the

the triangular spaces between the ends by bent springs, the tension of which could be regulated by screws. Thus, each complete ring had its tension controlled by two wedges, and the joints were staggered. With these pistons there was danger of the wedges being forced too far through and scoring the cylinders. A three-wedge metallic piston ring on similar lines was used by Isaac Dodds in 1831. Bury, and Forrester, used four segments for each of the two rings, with wedges between each pair.

After 1840, until superseded about 1857 by Ramsbottom's rings, one of the best pistons was Goodfellow's, used on Sharp's and McConnell's engines. It had two broad brass packing rings side by side. The inside of the joint between them was machined out to a V-shaped recess, into

which a third inner wedge-shaped cast iron spring ring was fitted. The latter had many rectangular notches right round its outer periphery. These notches were deep at the ends of the ring and diminished gradually to nothing in the middle. By this means the pressure was equalised round the circumference. This appears to have been the earliest application of a locomotive piston in which the elasticity of a ring without the aid of independent springs and wedges was used to obtain steam-tightness. The piston is illustrated in D. K. Clark's "Railway Machinery," page 215.

Connecting-rod ends were usually of the gib and cotter type, in most of which the cotters had to be hammered in. Stephenson's big end was an improvement in that the cotter had a screwed extension, which passed through a lug on the gib, so that the cotter could be drawn up by means of nuts above and below the lug. This cotter was

Very little need be said about the many varieties of gab motion valve gears, since illustrations and descriptions of most of them are given in D. K. Clark's "Railway Machinery." Until 1840 the motion was "indirect," and rocking shaft levers were interposed between the eccentric rods and valve spindles. The valve gear with separated fore and back gear eccentrics was similar to that of Stephenson's engine, Fig. 17, described previously. The evolution of the valve gears used by R. Stephenson and Co. leading up to the link motion is well described by Warren in Chapter XXVII. At the end of 1841 Messrs. Stephenson began to place the steam chest between the cylinders with almost vertical valve faces, and introduced a much simpler gab motion gear to give a direct motion to the valves (D. K. Clark, Fig. 34, page 24.)

Radial valve gears without eccentrics by

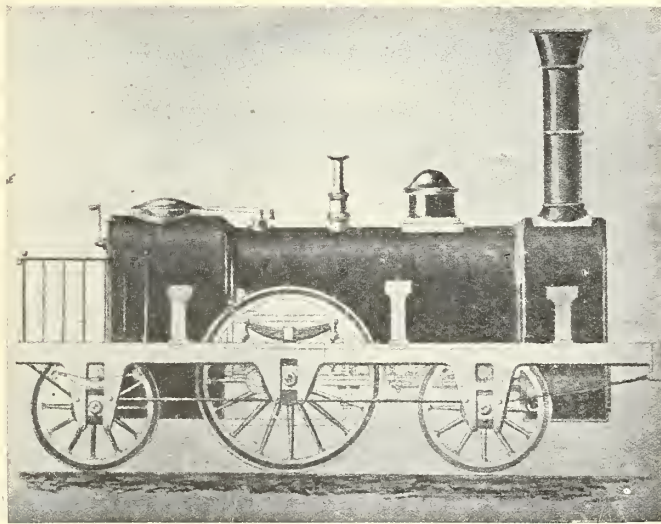

FIG. 36—W. & A. KITCHING'S ENGINE "RABY CASTLE," STOCKTON AND DARLINGTON RAILWAY, 1839

not so liable to shake loose, but many of the others were precariously held by a single set screw. The brasses were usually polygonal.

Sharp, Roberts' design was in advance of the period. The brasses were rectangular and regulated by a single cotter secured by three set screws. The front end of the strap was secured to the body of the rod by two dovetailed keys and a bolt. Whether this was the earliest use of the bolt which is seen in all modern strap ends the writer cannot say. The sharp angles of the keys were the weak point in these rods.

The exhaust passages of Sharp's engines of 1839-1842 were peculiar. Both exhausts were discharged from the cylinders into a cubical box placed midway between the inside cylinders, and the blast pipe was connected to the top of this box, which was intended to act as a form of "air vessel" to equalise the blast. It caused considerable back pressure in the cylinders.

Melling and by Hawthorn also made their appearance, but seem to have been little used. The valve motion was derived from a point near the middle of the connecting-rod as in Joy's gear. The engine shown by Fig. 33 had Hawthorn's gear, which is illustrated in D. K. Clark's "Railway Machinery," page 23, Fig. 33.

Miscellaneous Details.—W. W. Tomlinson in his history of the North-Eastern Railway records that the first sanding apparatus was used on the Newcastle and Carlisle Railway in 1838. The following year, W. Hawthorn brought out a "railway engine protector" to clear the rails from obstructions, and Whishaw specially mentions that all the engines on the railway mentioned in 1840 had "ploughs" in front of the leading wheels.

Coupled Engines with Inside Cylinders.—Before considering other types of 2-2-2 engines mention may be made of some of the coupled

engines of the period. Until 1837 these were of the 0-4-0 and its derivative, the 0-4-2 types. In 1837 R. Stephenson and Co. introduced the 2-4-0 type, as shown in Fig. 37, and two engines were exported to America and two to the Paris and Versailles Railway. The coupled wheels were

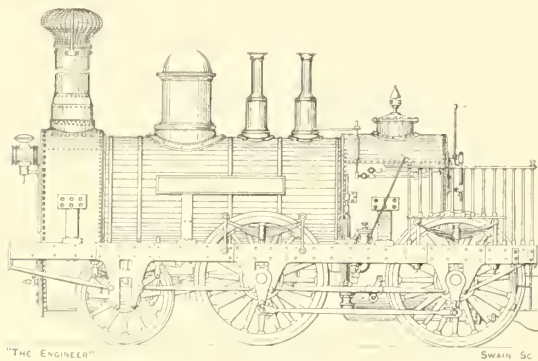

FIG. 37—STEPHENSON'S 2-4-0 ENGINE FOR THE PARIS AND VERSAILLES AND OTHER RAILWAYS, 1837

4ft. 6in. diameter and the cylinders 15in. by 18in. In these engines the dome was brought further forward and the regulator was placed in the smoke-box. The small size of the leading wheels, 3ft. 6in. diameter, allowed the cylinders to be placed horizontally, a great improvement upon the previous clumsy arrangement with slide bars below the leading (coupled) axle. The 2-4-0 type did not come into use in this country until about two years later, when a number of engines were built for the Great North of England Railway.

A noteworthy detail in all these coupled engines was the extreme length of the outside cranks and consequent throw of the coupling rods. With a stroke of 18in. and 9in. inside cranks the outside cranks were 14in. and in some cases 15in. long. The writer has never seen any account which gives a reason for this proportion. It may be that the designers of those days thought that the momentum of a rod with a long throw would better carry it over the dead centres, more especially as the engines were intended for slow-speed goods traffic. But even as late as 1857 there were some examples of coupled passenger engines in which the throw of the coupling rods was excessive.

The 0-4-2 engine—Fig. 38—built by Messrs. Hawthorn for the Newcastle and North Shields Railway in 1840, presents the peculiarity that the chimney is at the footplate end. It had a return-tube boiler with double fire-box, the latter being divided into two portions with semi-circular crowns and a water space between them. It had also a superheater or steam dryer, which consisted of a steam chamber in the upper part of the smoke-box with connections to the cylinders. The furnace gases on their way to the chimney passed through a number of vertical tubes in the chamber. This appears to have been the first actual application of a superheater to a locomotive.

On the Stockton and Darlington Railway the 0-4-0 type of engine with inside cylinders was used for passenger trains, and W. and A. Kitching's engine "Queen," built in 1837 for this line, is shown in Fig. 39. This engine, which had 4ft. 6in. coupled wheels and 12in. by 18in. cylinders, was subsequently converted to the 0-4-2 type. Hackworth's 0-4-0 engine "Dart" of 1840, unlike the "Queen," had inside bearings, 13in. by 16in. cylinders, and 4ft. 6in. wheels. The boiler carried a pressure of 70lb. For a passenger engine it had an extremely short wheel base of 4ft. 10in. only, with an excessive overhang at the back end—Fig. 40.

The six wheels coupled engine made very little progress during this period, and it was not until 1843 that its use for goods traffic extended. Two 0-6-0 engines by Tayleur, 1835, and the Haigh Foundry, 1839, similar to Stephenson's previous design, were put into service on the Leicester and Swannington Railway. They were, for that period, extremely powerful engines, having 16in. by 20in. cylinders and 4ft. 6in. wheels.

Outside Cylinder Engines.—In 1839 there appeared a number of outside cylinder locomotives of somewhat more modern type than Forrester's outside-framed engines. In the new engines the frames were inside and the crank pins were fixed in the wheels. The earliest of this type were built in 1839-40 for the Arbroath and Forfar Railway (Fig. 41) by Messrs. Stirling, of Dundee, where Patrick Stirling served his time under his uncle, who was the principal in the firm. The cylinders, 13in. by 18in., were steeply inclined at 1 in 4½ and had valves on the top worked by rocking shafts. The casting for the guide bars

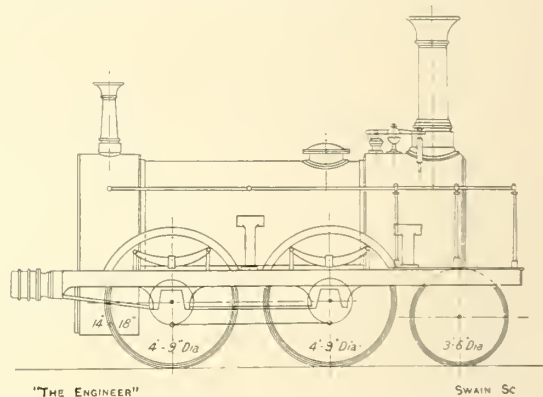

FIG. 38—HAWTHORN'S 0-4-2 STEAM DRYER LOCOMOTIVE, NEWCASTLE AND NORTH SHIELDS RAILWAY, 1840

was also unusual. The driving wheels were 5ft. diameter and carrying wheels 3ft. 6in. diameter. The boiler pressure appears to have been 50lb. The Glasgow, Paisley, Kilmarnock and Ayr Railway also had a number of somewhat similar engines from other Scotch firms in 1840-1, but with horizontal cylinders and 5ft. 6in. driving wheels.

The engine shown by Fig. 42 forms a landmark in locomotive design, and was the first to have

outside horizontal cylinders with rods working directly on to crank pins in the driving wheels, in combination with inside bearings and four coupled wheels. Two of the type were built by G. and J. Rennie, of Blackfriars, London, the first of which

diameter transversely. The driving wheels were flangeless and the trailing wheels had bearings in the outside frames only. The engines therefore had "mixed" framing and were the first of this type. The cylinders were 13in. by 18in., coupled

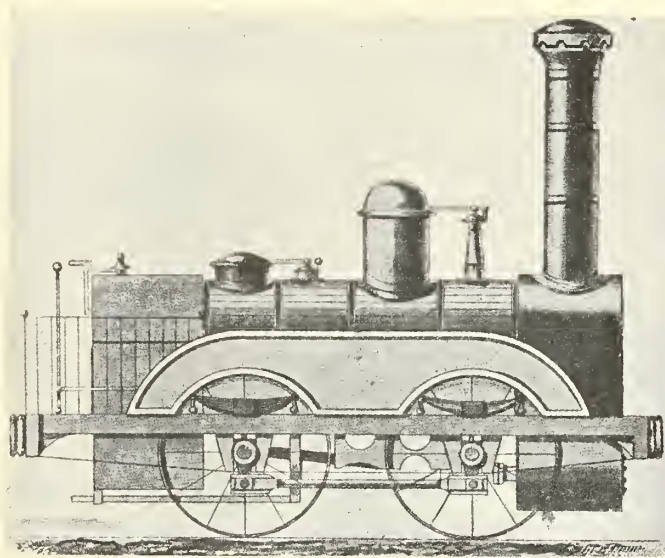

FIG. 39—W. & A. MITCHELL'S ENGINE "QUEEN," No. 29. STOCKTON AND DARLINGTON RAILWAY, 1838

was put to work in September, 1838, on the London and Croydon Railway for banking trains up the New Cross incline of 1 in 100.¹ Both inside and outside frames were of the sandwich type with 3in. thickness of timber between them. The outside cylinders were attached to both frames. The steam chests were above the cylinders and the valves were worked by rocking shafts. The feed pump was placed underneath the left-hand cylin-

wheels 5ft., and the trailing wheels 3ft. 6in. diameter. The oval fire-box was 3ft. by 3ft. 7in. Weight of engine in working order 14½ tons. This type of outside cylinder 0-4-2 engine, originated by Messrs. Rennie, never took root on English railways, on which the total number at no time exceeded half-a-dozen at the most. But some years later it was taken up by the Scottish locomotive engineers, beginning with Robert Sinclair



FIG. 40—HACKWORTH'S "DART," STOCKTON AND DARLINGTON RAILWAY, 1840
(From a photo taken in 1875, showing the engine as rebuilt)

der and worked from a lug on the crosshead. The fire-box was oval in section with the larger

¹ These engines are not in the list of London and Croydon locomotives given by Whishaw, nor in the one supplied officially by the Company to the Board of Trade in 1841, and as the line was not opened until June, 1839, nine months after they are said to have commenced work, it would appear probable that they were employed by the contractor for material trains in the construction of the line.

in 1847, followed in 1855-6 by Neilson and Co., Alexander Allan, and Patrick Stirling, and became a standard type, of which several hundreds were built down to 1881 for goods and mineral traffic over the Border.

The name of Alexander Allan is connected with the well-known "Crewe" type of outside cylinder engines, and although the original design had

its inception at the end of 1840, it will be more convenient to consider it during the next period.

Norris American Built Engines.—These were first imported in 1840-1 for the Birmingham and Gloucester Railway, and were of the outside cylinder 4-2-0 type. They had leading bogies

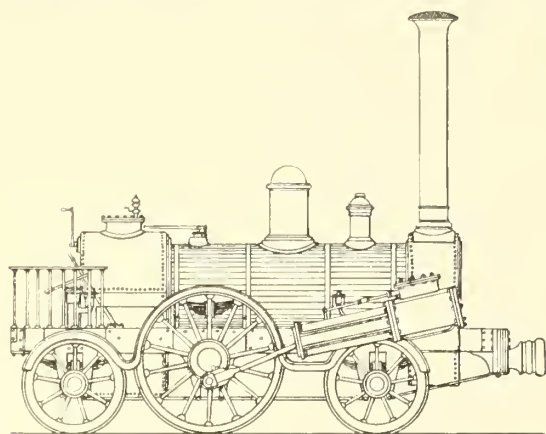

FIG. 41—STIRLING'S 2-2-2 OUTSIDE CYLINDER ENGINE, ARBROATH AND FORFAR RAILWAY, 1839-40

with cast iron wheels 2ft. 6in. diameter, the bogie wheel base being 3ft. only. The driving wheels 4ft. diameter—in some engines 4ft. 3in.—were placed immediately in front of the fire-box. The latter was of iron and of D section as in Bury's engines, and the bar frames were also very similar to those of Bury's design. Many parts, such as slide bars, were of cast iron. The cylinders in the eight original engines were 10½ in. by 18 in., but in later engines, both by Norris and two British firms, were increased to 11½ in. and 12½ in. diameter by 20 in. stroke. They were somewhat steeply inclined, and secured partly to the frame bar and

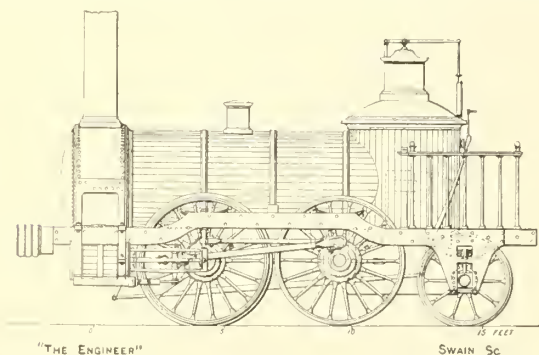

FIG. 42—RENNIE'S 0-4-2 OUTSIDE CYLINDER ENGINE, LONDON AND CROYDON RAILWAY, 1838

partly to the smoke-box. The weight varied from 9½ tons in the earlier to 13 tons in the later engines. An illustration of one of the engines is given by Fig. 42A.

It has been generally supposed that these engines were employed exclusively on the Lickey

incline of 1 in 37; actually they were used for the whole of the ordinary passenger and goods traffic between Birmingham and Gloucester, the mail and express trains alone excepted. An extra bank engine of the same class assisted the trains up the Lickey. At least 14 engines were built by Norris in Philadelphia, and there were also nine others by the Lancashire firms of Nasmyth, Gaskell and Co., and B. Hick and Co. Why American engines were imported it is difficult to say, though the Norris engines had been given a reputation for incline work in America which had attracted the attention of Captain Moorsom, the company's engineer. Colburn (*"Locomotive Engineering,"* page 52) throws some doubt upon their performances in America, and points out that unless the steam pressure had been 90 lb. instead of 60 lb. as given, their advertised feat could not have been accomplished.

In the obituary notice of Captain Moorsom (*"Proc.,"* Inst. C.E., Vol. 23, p. 501) it was stated that both Stephenson's and Bury's firms had declined the task of supplying locomotives for the Lickey. For negotiating the Lickey the

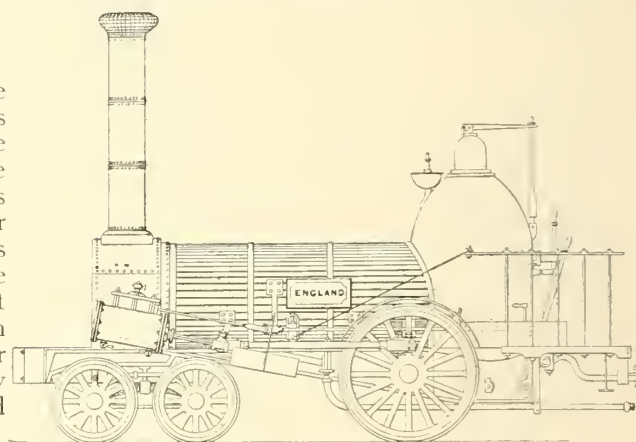

FIG. 42A—NORRIS LOCOMOTIVE, BIRMINGHAM AND GLOUCESTER RLY., 1840

Leicester and Swannington 0-6-0 engines would have probably been preferable, and were certainly more powerful. J. E. McConnell, who was locomotive superintendent of the line from 1841, stated that the Norris type engines were too light. Most of them were subsequently converted to saddle tank engines, and the design had no influence on subsequent British practice.

John Gray's Express Engines with Mixed Frames.—Before completing the account of progress during this period, special mention must be made of the 2-2-2 express engines, designed by John Gray, and built by Shepherd and Todd of Leeds in 1840, for the Hull and Selby Railway, of which he was locomotive superintendent. They, together with Gooch's contemporary Great Western engines, mark the first entry of the railway locomotive superintendent, into the design of engines since Hackworth's earlier attempts on the S. & D.R. Gray's locomotives were illustrated in

The Engineer, October 15th, 1920, p. 370. The type was that of Stephenson's patented six-wheeled engine with horizontal inside cylinders, but the frames and most of the details were entirely different. The framing was of the "mixed" type with inside bearings only for the driving axles, the leading and trailing axles having bearings in the outside frames. The driving wheels had the large diameter of 6ft., and the cylinders were 12in. by 24in. in the first engines, and 13in. by 24in. in two similar engines built for the York and North Midland Railway. The engines were fitted with Gray's patent expansion gear, known as the "horse-leg" motion, illustrated in D. K. Clark's "Railway Machinery," page 25, and in Colburn's "Locomotive Engineering," page 59. This was the earliest form of expansion gear used in locomotives, and had previously been tried in 1839 on the Liverpool and Manchester Railway. The reversing lever had a notched sector. The valves had a very long travel, about 6in. in full gear, the lap being 1½in. and the lead ¾in. The boiler had two domes, one over the fire-box and the other on the middle of the boiler. Both had vertical steam collecting branch pipes, the one in the rear dome being somewhat smaller in diameter than that in the other. Both branches joined a main horizontal steam pipe, at the end of which the regulator was placed in the smoke-box.

John Gray was an engineer who had sound ideas considerably ahead of his time. He increased the boiler pressure of his engines to 90 lb. and, shortly afterwards, in his goods engines to 100 lb. Moreover, at the time when all locomotive engineers were doing their utmost to keep the centre of gravity as low as possible, Gray appears to have been alone in realising that it was unnecessary to do so. In the passenger engines described above the centre of the boiler was 6ft. 2in. above rail level, a height about 4in. greater than that of the few standard gauge inside cylinder engines which then had 6ft. wheels, and, of course, considerably greater than that of the average engines, the driving wheels of which were only 5ft. 6in. In the outside cylinder engines of the London and South-Western Railway, built in 1843, with driving wheels of the large size of 6ft. 6½in., the boiler centre was only 5ft. 2½in. above rail level. When questioned on the subject in 1845 before the Gauge Commissioners, Gray replied that he did not care much about the centre of gravity. It was about ten years after the construction of the Hull and Selby engines before other engineers, beginning with McConnell, gradually broke away from the deeply rooted theory of a low centre of gravity. This theory, as will be shown, very greatly affected locomotive design during the period 1842 to 1850.

Tank Engines.—If Blenkinsop's and later Braithwaite and Ericsson's trial engines of 1829-30 be excepted, tank engines first made their appearance about 1837. An experimental four-wheeled express tank engine, with large driving wheels 6ft. 2½in. diameter, was constructed by Dr.

Church, of Birmingham. The cylinders, 11¼in. by 20in., were outside and placed under the foot-plate, and the driving wheels were under the boiler near the front of the engine. The small carrying wheels were at the trailing end. This engine is illustrated in D. K. Clark's "Railway Machinery," page 14.

But the first two tank engines to run regularly on a public railway were the "Victoria" and "Comet," built by Forrester and Co. for the Dublin and Kingstown Railway. The writer does not know the exact date when they were built, but they were probably contemporaneous with Church's engine. They were four-wheeled engines with outside cylinders and frames, similar to the "Vauxhall"—Fig. 24, *ante*—with the addition of tanks underneath. The driving wheels were 5ft. in diameter and the cylinders 11in. by 18in.

THE BROAD GAUGE ENGINES OF THE GREAT WESTERN RAILWAY, 1837 TO 1842.

Early Engines, 1837-8.—Although the Great Western Railway was not opened until June, 1838, some of the locomotives, including one dated 1837, had been delivered some time previously. With one, and possibly two exceptions, they formed the most extraordinary collection of freaks. It is not necessary to describe them in detail, since they had no influence on the development of the locomotive, but a few words concerning them will not be out of place.

Six 2-2-2 engines, built by Tayleur and Co., had 8ft. driving wheels; three of them had 14in. by 16in. cylinders, and three others 12in. by 16in. cylinders. As the steam pressure was only about 50 lb. to 55 lb., and the total heating surface about 500 square feet, they must have been hard put to it to keep themselves in motion, even without a train. Nevertheless, with the exception of two Stephenson locomotives, they were stated to have been the best of a queer lot. In the Tayleur and some other engines the driving axles had the horns and axle-boxes placed above the framing.

Then there were two 2-2-2 engines by Mather, Dixon and Co., "Ajax" and "Mars," stated to have had 10ft. driving wheels and cylinders 14in. by 20in. Their main characteristic was that all wheel centres, including the 10ft. drivers, were built up of riveted plates in the form of discs. Whether they ever worked any trains in their original form is doubtful, and they appear to have had the wheels reduced to 8ft. diameter, the size recorded in Whishaw's "Railways of Great Britain and Ireland." According to records at Paddington "Ajax" ceased work in June, 1840, with a mileage of 15264 miles.

There was also another engine with 10ft. driving wheels, on T. E. Harrison's patent, with the engine and machinery on one frame, which formed a separate carriage from that on which the boiler was placed. This engine, which had 16in. by 20in. cylinders, was built by Messrs. Hawthorn. Another Harrison engine by the same firm

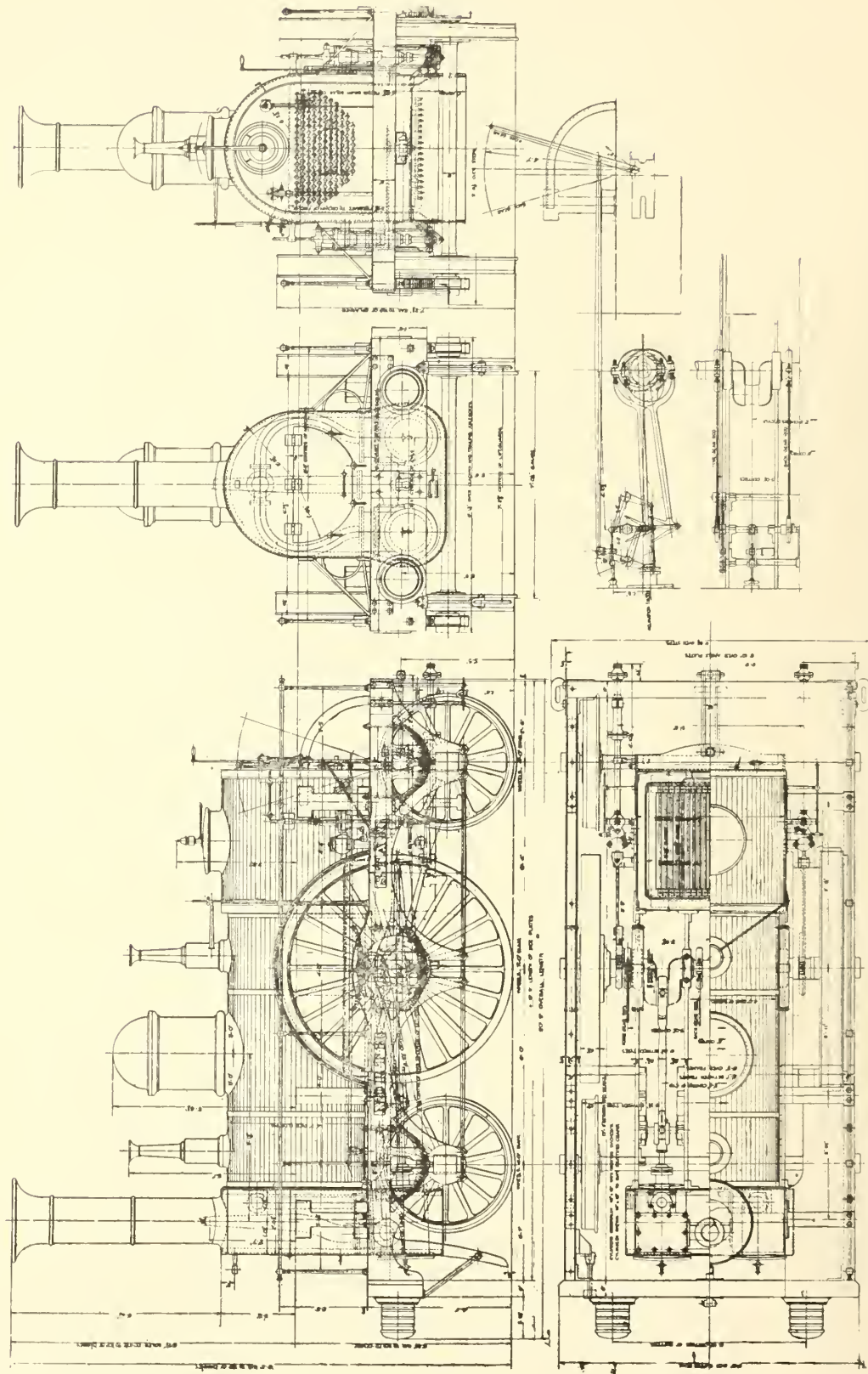

FIG. 13—GENERAL ARRANGEMENT OF THE "NORTH STAR" G.W.R. OF 1837, AS RECONSTRUCTED AT SWINDON WORKS IN 1925
Reproduced from drawing by courtesy of Mr. C. B. Collett, Chief Mechanical Engineer
For a detailed description see *The Locomotive*, Vol. XXVII, 1926, page 10 *et seq*

had 6ft. coupled wheels geared up by means of spur wheels in the ratio of 3 to 1, the equivalent of driving wheels 18ft. in diameter. Illustrations of some of the engines will be found in *The Engineer* Supplement of December 16th, 1910, and a full illustrated account of all of them in *The Locomotive*, Vol. VI., 1901.²

The responsibility for the design of many of these freaks has never been cleared up satisfactorily. They were mostly ordered before Daniel Gooch took charge of the locomotive department, and in his diaries it was stated that he was not very pleased with the designs, and that he was very uneasy about their working. Brunel stated that he specified conditions only and neither compelled nor induced the makers to adopt certain dimensions or modes of construction. On the other hand, makers, such as Tayleur, who had been building standard gauge engines with 5ft. 6in. wheels and 13in. by 16in. cylinders, must certainly have had sufficient knowledge of the effect on the tractive force of large 8ft. wheels, without making matters worse by the use of cylinders only 12in. by 16in. Long before 1837 these facts were known and recognised. Brunel himself admitted before the Gauge Commission in 1845 that the original intention had been to employ large wheels of 7ft. to 8ft. diameter, and therefore it seems to the writer that he probably interfered in some way and was not entirely blameless.

Stephenson's "Star" Class.—The only successful Great Western Railway early engines were built by R. Stephenson and Co., and were named "North Star" and "Morning Star." The former is shown by Fig. 43. It was originally intended for the New Orleans Railway, U.S.A., of 5ft. 6in. gauge, but was altered to suit the 7ft. gauge. It was built in 1837, tested on the Great Western Railway early in 1838, and worked the first passenger train out of Paddington on June 4th, 1838, when the railway was opened.

The driving wheels were 7ft. diameter, and the cylinders 16in. by 16in. According to Whishaw, the fire-box heating surface was 66.16 square feet, and the tube heating surface 640 square feet, calculated on the fire and not on the water side. Warren, page 341, states that the boiler barrel, 8ft. 6in. long by 4ft. diameter, contained 167 $\frac{1}{8}$ in. tubes, and that the total heating surface was about 711 square feet. The last figure agrees very nearly with Whishaw, but it is not stated whether fire or water side surface is intended. As built the wheel base was 6ft. + 6ft. 4in. = 12ft. 4in. It was lengthened to 13ft. 4in. to accommodate a longer boiler when the engine was afterwards rebuilt.

The "Morning Star" was a somewhat similar engine, but the driving wheels were only 6ft. 6in. diameter.

² Original sketches of many of the early engines as running during the period 1840-48 are preserved at the Science Museum, in the note books of a former employee of the G.W.R. named Lane.

The "North Star" was a very successful engine. In 1854 it was re-boilered at Swindon with a domeless boiler, the cylinders at the same time being enlarged to 16in. by 18in., and in this form with the original framing it continued at work until December, 1870. The total heating surface of the new boiler was 850 square feet, of which the fire-box surface was 94 square feet. The engine was preserved at Swindon for many years.

A full size model of the "North Star" was constructed at the G.W.R. Swindon works in 1925, and shown at the Centenary celebrations at Darlington in July of that year. Every part of this model is of metal except the boiler and cylinders, which are of wood. It is now kept at Swindon—Fig. 43.

The model has the excentric driven short stroke pumps on the side of the fire-box, which are shown on the original drawings of the engine, and as in Fig. 37. But at this period Stephenson generally used long stroke pumps off the crosshead.

Messrs. Stephenson subsequently, from 1839 to 1841, built ten other engines of the "Star" class, with 7ft. driving wheels, the cylinders varying from 15in. by 18in. in two of the 1839 engines to 15 $\frac{1}{2}$ in. by 19in. in the last two built in 1841. All these engines had domed fire-box casings of some kind instead of the original round topped raised type of the "North Star." They also had six bearings, two outside and four inside, for the driving axles.

The inside bearings were held in stay plates, which extended between smoke-box and fire-box casing.

D. Gooch's engines.—When Daniel Gooch was authorised to make his own designs for the Great Western Railway, he took Stephenson's "North Star" type as a pattern, but enlarged the dimensions and modified some of the details. The drawings were made at Swindon, and for the first time in history we meet with standardisation on an extensive scale for an individual railway. Full specifications and templates were supplied to each manufacturer to ensure interchangeability.

Of the new locomotives (1840-1842) there were sixty-two express engines. They are shown in Figs. 44 and 45, by kind permission of Nasmyth, Wilson and Co., Limited, Manchester, who as Nasmyth, Gaskell and Co. built sixteen of them. As originally made, the cylinders were 15in. by 18in., though about ten years later they were enlarged to 16in. by 20in. The driving wheels were 7ft. diameter, carrying wheels 4ft. diameter, and wheel base 13ft. 2in. equally divided. In spite of the breadth of the gauge, the boiler was only 4ft. diameter, and contained 131 2in. tubes, but the fire-box casing was 4ft. 8 $\frac{1}{2}$ in. wide by 4ft. 6in. long. Heating surface of tubes, 557 square feet, of fire-box 90.6 square feet; total, 647.6 square feet. Weight in working order, about 24 tons. All these engines were direct derivatives of

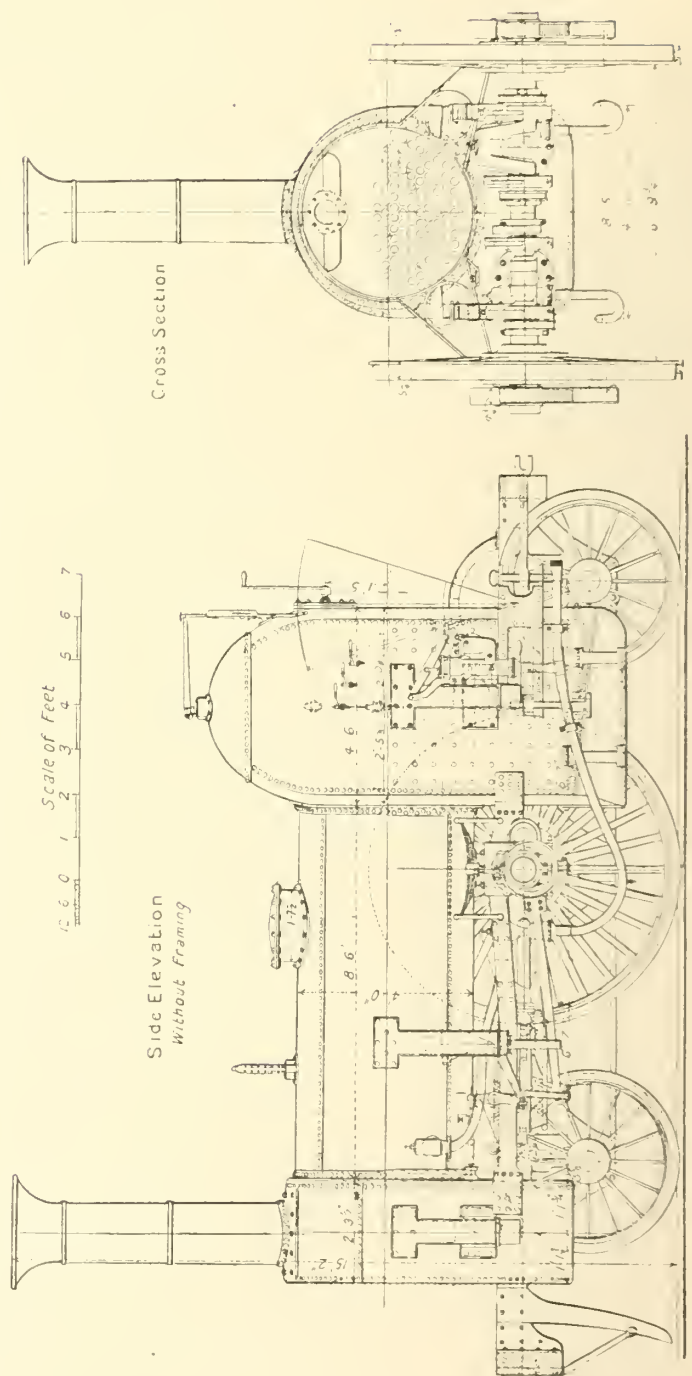
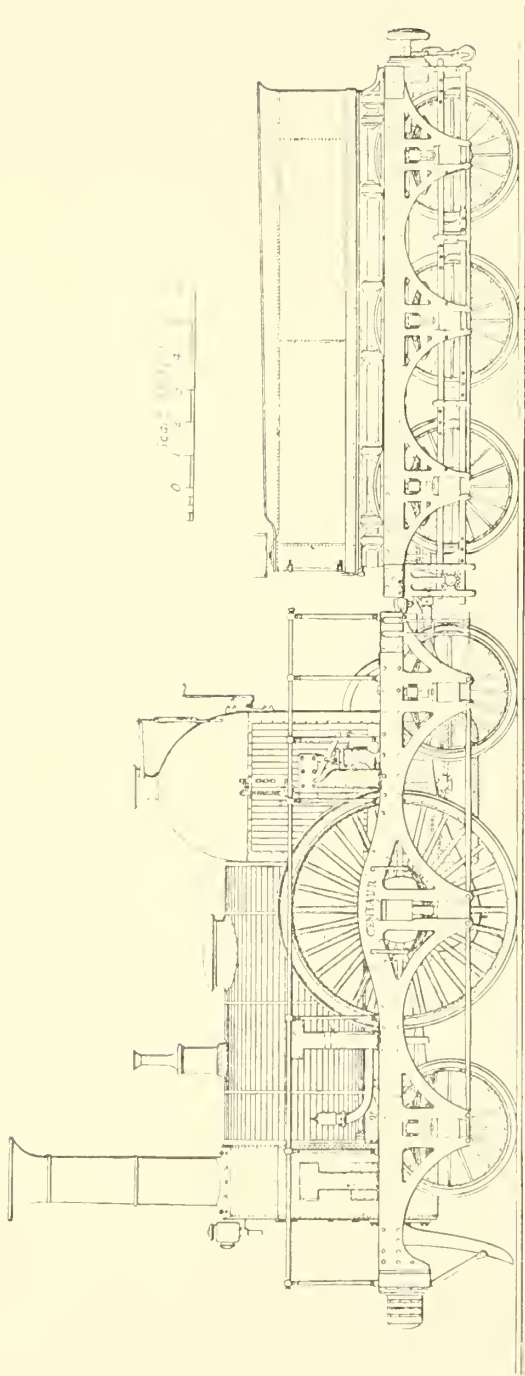

FIGS. 44 and 45—G.W. LOCOMOTIVE "CENTAUR," ELEVATIONS AND SECTION, BUILT BY NASMYTH, Gaskell & CO., 1841

Stephenson's "North Star," and had a similar pattern of outside framing and centre stay bearings. The engines were built by the following makers:—

Jones, Turner and Evans, Newton-le-Willows ...	6
Sharp, Roberts, Manchester	10
Fenton, Murray and Jackson, Leeds	20
Nasmyth, Gaskell and Co., Manchester... ..	16
R. B. Longridge and Co., Bedlington	6
Stothert and Slaughter, Bristol	2
G. and J. Rennie, London	2

62

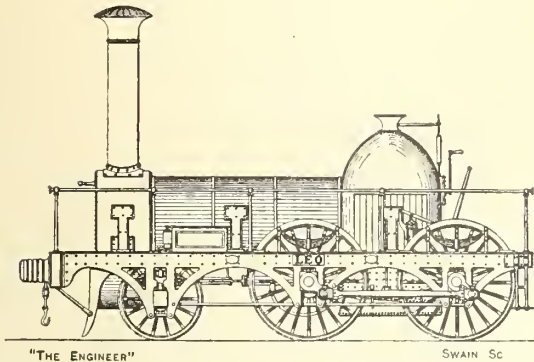

FIG. 46—G. W. BROAD GAUGE GOODS LOCOMOTIVE "LEO,"
BY ROTHWELL & CO., 1841

A smaller type of 2-2-2 engine was built for local and branch line passenger trains. They were similar in appearance, but had 6ft. driving wheels and 14in. by 18in. cylinders (three 15in. by 18in.), but the wheel base, for some unknown reason, was 13ft. 8in., or 6in. longer than that of the express engines. There were twenty-one of this class by Hawthorn (eight), Sharp, Roberts (five), and Stothert and Slaughter (eight). They were intended to work between Swindon and Bristol, but their adhesive weight was deficient, and consequently they were afterwards converted to saddle-tank engines.

The first eighteen goods engines of 1841-2 were of the 2-4-0 type (Fig. 46). They had 5ft. coupled wheels and 15in. by 18in. cylinders. Finally there were built four 0-6-0 engines (Fig. 47). They came from the works of Nasmyth, Gaskell and Co. in 1842, and were an afterthought on the part of Gooch, who had ordered 7ft. express engines, but subsequently, wishing to try six-coupled goods engines, altered the order. They had 16in. by 18in. cylinders, 5ft. wheels, and 12ft. 6in. wheel base. The boilers were similar to those of the express engines.

The usual pressure of all Gooch's early engines was 50 lb. per square inch, but there are reasons for believing that a few of the express engines carried 55 lb. pressure.

No broad-gauge engines were built between 1842 and 1846.

Outside Sandwich Frames on the Great Western Railway.—The peculiar type of outside sandwich framing originated by Stephenson should be noticed. The triangular apertures were probably

cut out to lighten it, and in all of Sir Daniel Gooch's engines, both broad and standard gauge, until 1865, this form of framing was employed. In 1872 it was again taken up, and a large number of standard gauge engines were built until 1891, when it was abandoned. The technical history of sandwich framing, more especially on the Great Western Railway, is of interest. Originally ash was the wood used in many engines, but subsequently not only the Great Western, but also the private locomotive builders, employed oak as the strongest timber obtainable, and this continued to be the practice for many years. But one disadvantage of this type of frame was that the bolts, of which a large number were necessary to secure the flitch plates to the timber, tended to work loose. It was found during W. Dean's superintendency that the acid existing in the oak caused the bolts to corrode. Afterwards in the later engines of 1886 to 1891 teak, an oily wood, was substituted and trouble from this cause ceased.

The use of sandwich frames on the Great Western Railway long after all other companies and locomotive builders had discarded them was largely due to the longitudinal sleeper road, of which even at the time of the abolition of the broad gauge in 1892 there were many miles, not only on the main line to Penzance, which was laid entirely on that system, but also on much of the South Wales, Weymouth and Birmingham sections. It is an undeniable fact, to which the writer can testify from considerable experience on the footplates of both sandwich and solid plate

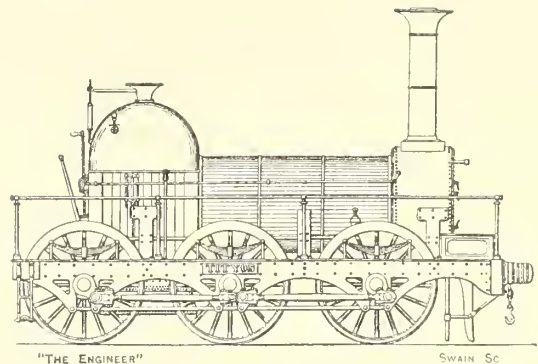

FIG. 47—G.W. BROAD GAUGE GOODS LOCOMOTIVE "TITYOS,"
BY NASMYTH, GASKELL & CO., 1842.

framed engines, that the former ran much more smoothly and with less vibration on the longitudinal sleeper road. The difference was extremely marked, and was even noticeable, though to a considerably less extent, on the ordinary cross sleeper road. The "balk" road, as the drivers used to term it, was very "dead." For this reason the Great Western also used longer springs than other companies, and many of them were of the "open plate" type, in which each long main plate was separated from the one next to it by a short thin plate.

Chapter V — 1841-45

THE principal feature of this period was the introduction and development by R. Stephenson and Co. of the "long boiler" engine, and the temporary abandonment by this and some other firms of what may be termed the "standard" locomotive, evolved from Stephenson's "Patentee" of 1833. The standard six-wheeled engine had the trailing wheels behind the fire-box, but in the long boiler engine all three axles were in front of it.

Before considering the long boiler locomotive it will be more convenient to follow the Hackworth and other schools, and also deal with the progress of the standard engine, of which another outside cylinder type appeared.

smoke-box end, the connecting-rods driving the rear pair of wheels. Steam was taken from the dome through a large external elbow pipe to valve chests above the cylinders, and the exhaust pipe to the smoke-box was also outside. A form of gab motion with very long valve spindles was used. The Hackworth flue boiler was abandoned, and a long multitubular boiler 13ft. long with 213 $1\frac{1}{2}$ in. tubes substituted. The grate area was only 10 square feet, the fire-box being too small for the boiler, which had a total heating surface of 1363 square feet, pressure 75 lb. The weight was very unevenly distributed; of the total of 22 tons 7 cwt., 8 tons 15 cwt. were carried at the driving wheels, and only 5 tons 18 cwt. at the leading

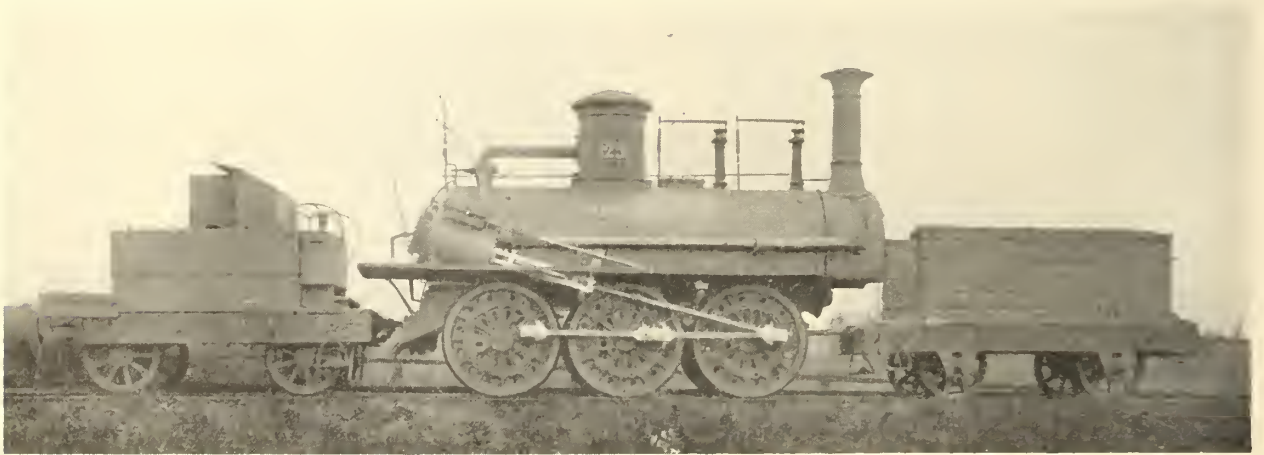

FIG. 48—STOCKTON AND DARLINGTON RAILWAY LOCOMOTIVE "DERWENT" No. 25, BUILT BY W. & A. KITCHING, 1845
As in steam at the Railway Centenary, 1925, and now preserved at Bank Top Station, Darlington.

Stockton and Darlington Railway and Later Hackworth Engines.—Although the last engines designed by T. Hackworth for the Stockton and Darlington Railway were built in 1842, his designs still continued to affect the type of engine on that line. Amongst the Hackworth features retained were the steeply inclined cylinders, cast iron plug wheels, and to some extent the combined flue and return multitubular boiler. Some engines by W. and A. Kitching from 1845 onwards had the inclined cylinders attached to the boiler at the back, the connecting-rods driving the leading wheels. These were of the "Derwent" class—Fig. 48—of which the last came out in January, 1848. It had the Hackworth boiler mentioned above, 4ft. cast iron wheels, and $14\frac{1}{2}$ in. by 24in. cylinders. At the same period six engines—Fig. 49—were built at the Shildon works of the company in 1845-6, in which William Bouch, the locomotive superintendent, introduced important modifications. The steeply inclined cylinders were retained, but were attached to the boiler at the

wheels. Two tenders with small 2ft. wheels were attached, one at each end, though one would have sufficed.

Of another type of engine by T. Hackworth unfortunately no detailed particulars appear to have been preserved. A few were built at his own works at Shildon. Their special feature was outside horizontal cylinders situated at the trailing end. Joseph Tomlinson ("Proc.," Inst. Mech. Engrs., 1890) stated that they were the first to be built with outside horizontal cylinders, but it is doubtful whether they preceded the Rennie engines of 1839 for the London and Croydon Railway. A similar type was afterwards built by Fossick and Hackworth, of Stockton, for the Stockton and Hartlepool Railways. The firm of Fossick and Hackworth was founded about 1840 by Thomas Hackworth, the brother of Timothy, who carried on at Stockton many of the traditions originated at Shildon, and until 1864 built engines with inclined cylinders attached to the boiler.

Bury Type Engine.—Bury held tenaciously to

the four-wheeled bar framed locomotive, merely enlarging the dimensions, though in 1845 his passenger engines, with 5ft. 9in. driving wheels, had only 14in. by 18in. cylinders. The 0-4-0 goods engines were built with 5ft. wheels and 14in. by 24in. cylinders. The only firms which

locomotives designed by John Gray for the Hull and Selby Railway merit attention. Six—Fig. 50—were built in 1842 to 1844 by Shepherd and Todd and at the company's shops at Hull. The coupled wheels were 5ft. 6in. diameter and the cylinders (inclined upwards) 16in. by 24in. The



FIG. 49—STOCKTON AND DARLINGTON LOCOMOTIVE No. 33, BUILT AT SHILDON, 1846

followed Bury's practice during this period were B. Hick and Son, the Haigh Foundry, and W. Fairbairn and Sons, though the last-named firm confined itself strictly to four-wheeled bar-framed goods engines, and built its passenger engines of the 2-2-2 outside-framed Stephenson type.

boiler pressure, at least in the later engines, was 100 lb. The valve gear was Gray's "horse-leg" motion. A peculiar feature was that the leading wheels only had outside bearings, and the coupling rods worked on pins of the form of cranked shafts between the frames and the wheels. Gray's object

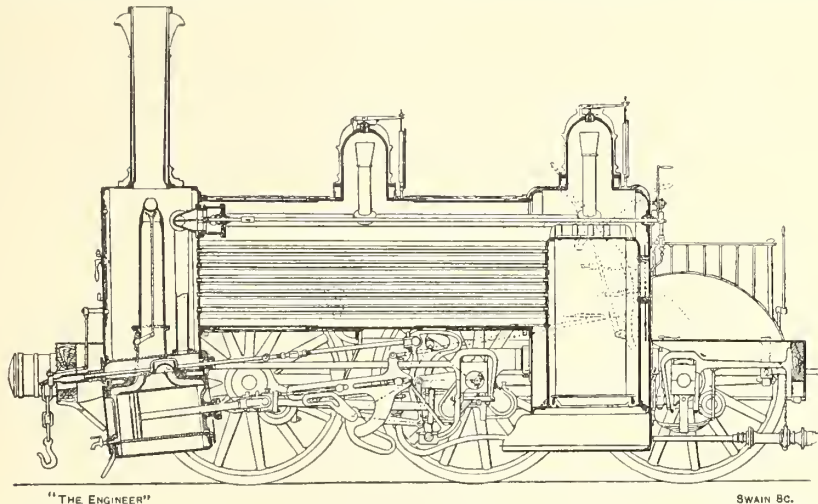

FIG. 50—GRAY'S HULL AND SELBY RAILWAY ENGINE, BUILT BY SHEPHERD & TODD AND BY THE RAILWAY, 1842-44

But at the end of 1845 Bury was compelled to adopt the six-wheeled engine, owing partly to the increasing weight of trains and also to the pressure of technical opinion, but he retained the bar frames.

Standard Engines with Inside Cylinders.—Of the "standard" inside cylinder engines the 0-6-0

appears to have been to space the leading springs as widely apart as possible to prevent "rolling" of the engine, since he pitched his boilers at a considerable height above rail level.

Certain firms did not adopt Stephenson's patent long boiler engine. Amongst them were R. and W. Hawthorn, who at this period adhered to the

"standard" engine for all classes, passenger and goods. A fine 2-2-2 express engine, the "Richmond," was built by this firm for the Great North of England Railway in May, 1845, but unfortunately no drawings of it appear to exist. It had inside cylinders, 16in. by 21in., outside sandwich frames, and 6ft. 6in. driving wheels. W. W. Tomlinson (*History of the N.E.R.*) records that in August, 1845, it took a train of seven coaches from Darlington to York, 44½ miles, at an average speed of 51 miles per hour.

Sharp Brothers and W. Fairbairn and Sons rarely built "long boiler" passenger engines, though they subsequently adopted the principle for goods engines. Their 2-2-2 passenger engines of this period were simply enlargements of the engine—Fig. 35 *ante*. An interesting example of this type was the Stockton and Darlington engine No. 50, "Meteor"—Fig. 51—designed by Bouch after the pattern of a "Sharp" and built at the company's works at Shildon, 1843. This engine

sort. The fire-box side stays were not riveted over inside the box, but had long projecting heads shaped like the frustrum of a pyramid. As coke was the fuel used there was no flame licking action, though abrasion was caused by particles of coke, and plenty of material was left on the heads to allow for this wear. The average weight of these engines in working order was 15½ tons. The date plate bears the inscription: "Liverpool and Manchester Railway Company, February, 1842." The small size of the engines used on the Liverpool and Manchester Railway in comparison with those on other railways in 1845 was commented on before the Gauge Commission.

In 1843 the oldest locomotive building firm in the kingdom, Messrs. Fenton, Murray and Jackson, of Leeds, dropped out of existence.

The "Crewe" Type of Outside Cylinder Locomotive.—The development of the outside cylinder engine by the "Crewe" school was an important epoch in locomotive history, since a type

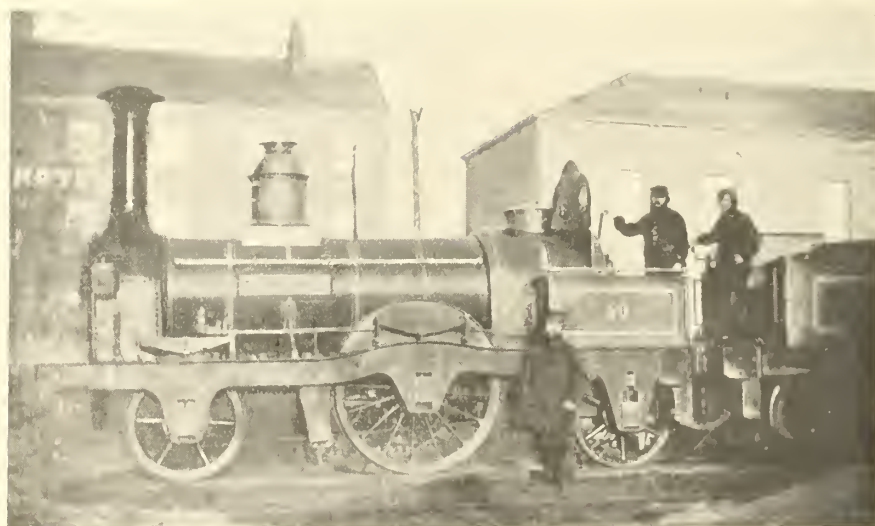

FIG. 51—STOCKTON AND DARLINGTON ENGINE "METEOR," BUILT AT SHILDON WORKS, 1843

had 5ft. driving wheels and 12in. by 18in. cylinders, when new.

The 2-2-2 engines of the Liverpool and Manchester Railway—Figs. 52 and 53¹—designed by John Dewrance, were noted for their neatness. They were known as the "Bird" class on account of the names of birds which they bore, and all were built in 1841-1844 at the company's own works at Edgehill, Liverpool. They were comparatively small with 12in. by 18in. cylinders, 5ft. driving wheels, and 3ft. 6in. carrying wheels. Their chief feature was the solid forged wrought iron wheel centres, an early example of the

¹ The illustrations Figs. 52 and 53 are reproduced from drawings kindly supplied by Sir John Dewrance, K.B.E., who is the son of the late John Dewrance, locomotive superintendent of the Liverpool and Manchester Railway. The latter died in 1861.

was introduced which had great influence on the locomotive design of several important railways for more than forty years, and at one period largely affected French practice. At the end of 1840 Alexander Allan was works manager of the Grand Junction Railway at Liverpool, and J. Buddicom was locomotive superintendent. The stock of locomotives then consisted of about seventy 2-2-2 engines with inside cylinders, outside frames and crank axles. The G.J.R. had junctions with the L. and M.R. near Newton-le-Willows by means of two sharp curves, in running over which a considerable number of crank axles were broken. Allan, prompted by his previous experience with G. Forrester and Co., obtained permission to reconstruct three of the engines with straight driving axles and outside cylinders. As in Forrester's engines, the cylinders were firmly secured between

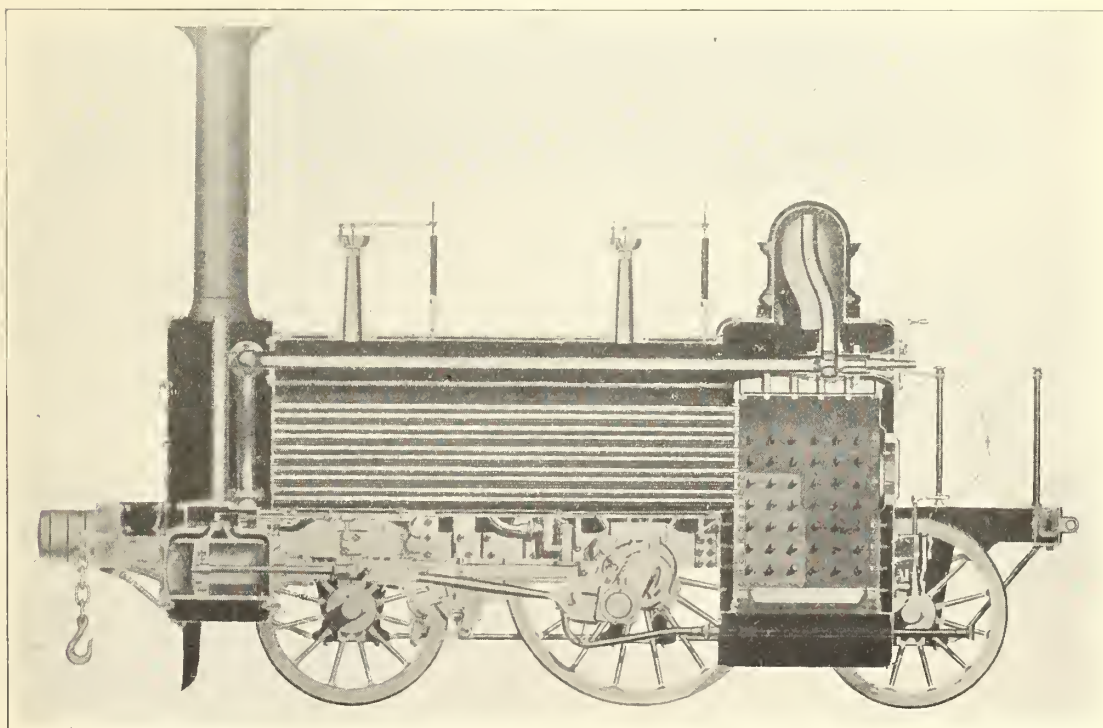
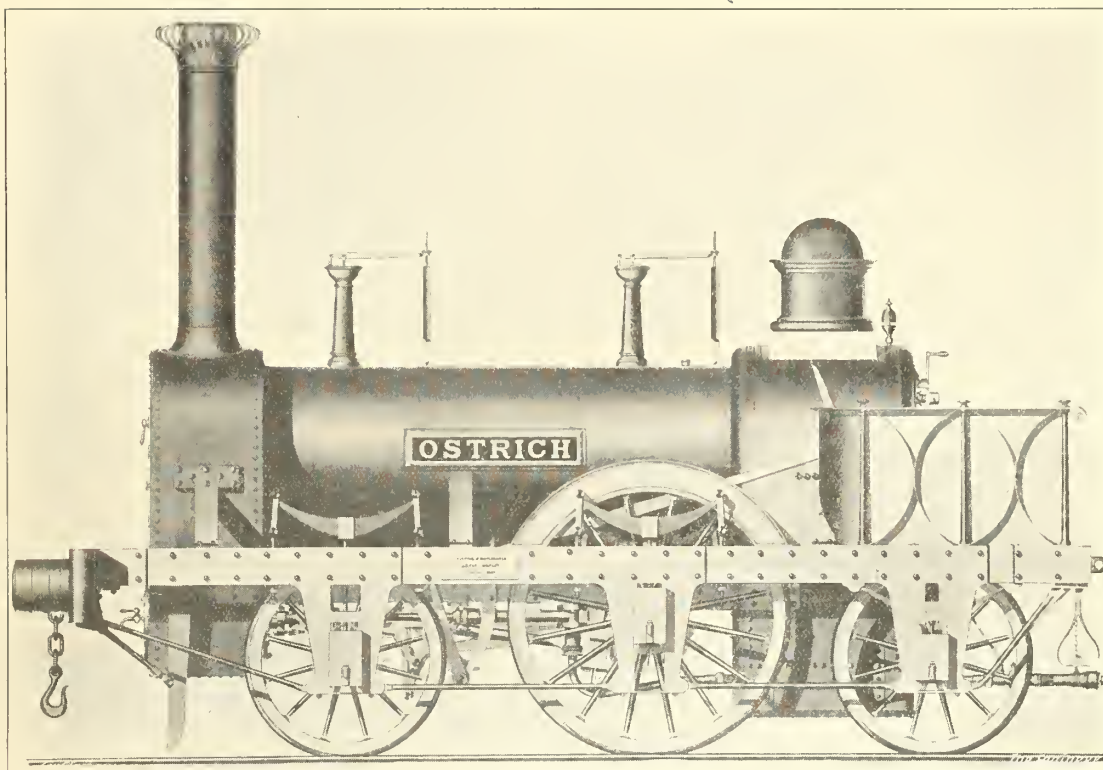

FIGS. 52 and 53.—JOHN DEWRANCE'S LIVERPOOL AND MANCHESTER RAILWAY ENGINE, 1842

the inside and outside frames. The frames, together with the motion, were entirely new, but the crank pins were fixed directly in the driving wheels. There is some, though uncertain, evidence that the first two engines may have had outside cranks and bearings for the driving axle, as in Forrester's "boxer" design, but the third engine was certainly of the "Crewe" type, in which only the two carrying axles had outside bearings. After a number of these engines had been reconstructed with the old boilers, 5ft. 6in. wheels and 13in. by 20in. cylinders, the G.J.R. shops were removed to Crewe in 1843, where entirely new engines of the type were built.

The type as developed at Crewe in 1845-1846—Fig. 54—had 6ft. driving wheels, 3ft. 6in. carrying wheels, and 15in. by 20in. cylinders. Wheel base leading to driving, 5ft. 6in.; driving to

medium of rocking shafts. This awkward indirect motion necessitated both excentric rods being inclined downwards, with the Stephenson expansion link in a very low position. In engines built after 1848 direct motion was used.

The Allan type of passenger engine was built at Crewe until the end of 1858, and also became standard on the Caledonian, and many other Scottish railways, including the Highland.

The 2-4-0 "Crewe" goods engine, also by Allan, was first built in 1844. It was similar in general design to the passenger engine, but had coupled driving and trailing wheels, 5ft. diameter. The cylinders were 15in. by 20in.—the first engine of 1844 had 13in. by 20in. cylinders—enlarged in later engines to 15½in. by 20in. Weight about 19½ tons. Many of these engines were built, and the design formed the basis of the later Caledonian

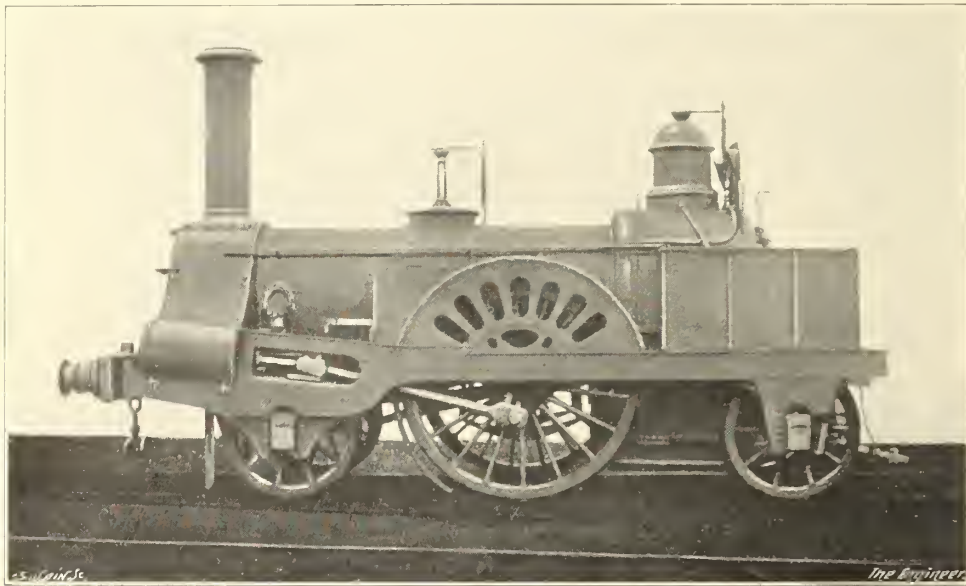

FIG. 54—ALLAN'S "CREWE" TYPE PASSENGER ENGINE, L. & N.W. RLY., 1845

trailing, 6ft. 6in.; heating surface of tubes, 658 square feet; of fire-box, 51 square feet; total, 709 square feet; grate area, 10.5 square feet; weight in working order, 18 tons, of which about 9 tons rested on the driving wheels. The cylinders, slightly inclined, were placed well forward, and securely fixed between the inside and outside framing. To obtain as long a connecting-rod as possible, the small end was forked with two short arms, which took hold of gudgeon journals on each side of the crosshead. This form of crosshead, designed by Allan in 1840, was standard in all Crewe-built simple engines, both with outside and inside cylinders, for a very long period, and in fact F. W. Webb used this form of crosshead connection except for engines fitted with the Joy valve gear. In the earlier engines of 1845-8 the valves, though working on vertical faces at the sides of the cylinders, were actuated through the

passenger and fast goods engines until 1877.

It has been incorrectly stated that the "Crewe" coupled goods engines were the earliest to have the 2-4-0 wheel arrangement. Inside cylinder 2-4-0 engines were in use from 1837 onwards, and some with outside cylinders had been built by R. Stephenson and Co. for abroad before Allan's first engine appeared.

The largest standard gauge express engines of this period of similar type to the "Crewe" engines were built at Nine Elms Works in 1843-4 by the L. and S.W.R. to the designs of John V. Gooch. They had large driving wheels, 6ft. 6in. diameter, and cylinders, 14¼in. by 21in.; wheel base, 12ft. 8½in.; total heating surface, 899 square feet. The boiler was domeless and steam was taken from the open end of a long steam pipe at a point above the back of the fire-box. Thence it was conducted to a slide valve gridiron regulator

placed between the outside cylinders at the bottom of the smoke-box. This form of regulator, placed over the steam chest, was due to R. Stephenson and Co. in 1841, but Warren adds that it did not survive long in this firm's designs. Gooch, however, used it in nearly all his engines on the L. and S.W. Railway, and afterwards on the Eastern Counties Railway until about 1856. The second boiler ring from the front was dished inwards at each side to allow room for the Gooch expansion link. The $\frac{3}{4}$ in. inside frame plates were joggled $2\frac{3}{4}$ in. each side at the back to accommodate a wider fire-box. The latter had a transverse partition with corrugated sides. These engines are illustrated in D. K. Clark's "Railway Machinery," Plates X. and XI.

Long Boiler Engines: Stephenson's Patent.—

engine, see Warren, Chap. XXVI., page 346.

The boiler barrels of that day were about 8ft. to 8ft. 6in. long and 3ft. 6in. to 3ft. 8in. diameter. The fire-box was without a brick arch, and an enormous amount of heat was carried away, as proved by experiments carried out on the North Midland Railway. In estimating the merits of long boiler engines, this and the other factors mentioned must be kept in mind.

The first long boiler engines were of the 2-2-2 type, with inside cylinders, 14in. by 20in., and 5ft. 6in. driving wheels. They appeared in the latter part of 1841, one on the York and North Midland Railway, and the other on the Northern and Eastern Railway (5ft. gauge), from London to Bishop's Stortford. The latter engine is shown by Fig. 55. The boiler barrel was 11ft. 3in. long

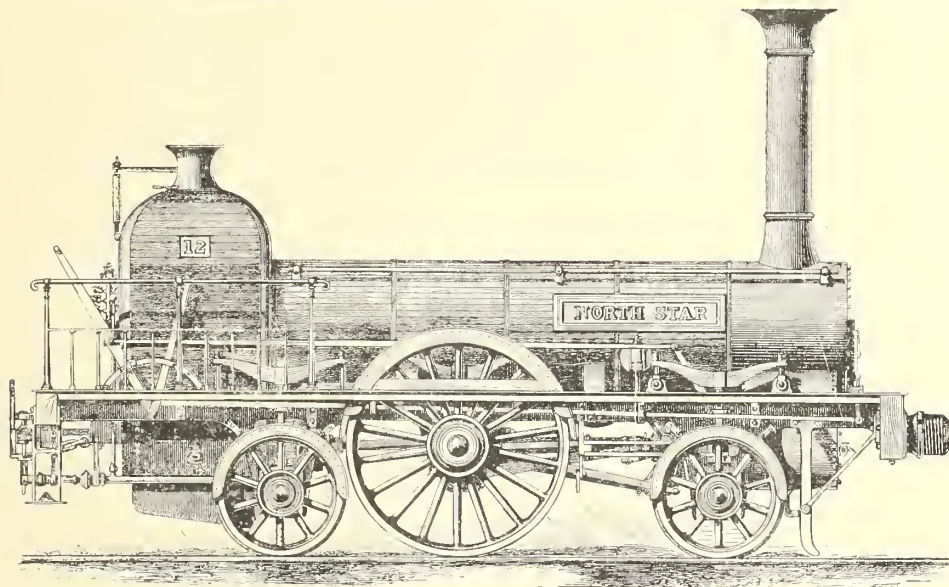

FIG. 55—STEPHENSON'S "LONG BOILER" PASSENGER ENGINE, NORTHERN AND EASTERN RAILWAY, 1841

The long boiler engine, in which all three axles were placed underneath the boiler in front of the fire-box, was introduced by R. Stephenson in 1841, with the principal object of providing greater boiler power accompanied by reduced loss of heat and unburnt fuel through smoke-box and chimney. Two additional factors of importance were the supposed necessity for having the centre of gravity of the engine as low as possible, and the small turntables which necessitated an engine wheel base restricted to about 12ft.

The low centre of gravity theory was maintained as a cardinal principle by every engineer of that day, with the exception of John Gray. It had the effect of limiting the diameter of the boiler in passenger engines with large driving wheels so that when engines of greater power became necessary, R. Stephenson decided to increase the heating surface by lengthening the tubes. For a complete account of the reasons which caused Robert Stephenson to design the "long boiler"

by 3ft. 2in. outside diameter, its centre being 5ft. 7in. above rail level. The leading wheels had a diameter of 3ft. and the wheel base was 6ft. 4 $\frac{1}{2}$ in. + 4ft. 4 $\frac{1}{2}$ in.

This engine presented several novel details. Outside sandwich frames were discarded and the main frames, consisting of $\frac{3}{4}$ in. iron plates which extended the whole length of the engine, were placed inside the wheels. In deciding upon this form of framing, together with an overhung fire-box, R. Stephenson had been influenced both by motives of economy and by the serviceability of Bury's engines—Warren, page 350. The cylinders were bolted together, and the steam chest, instead of being above the cylinders, was placed between them and was common to both, the valves working on vertical faces. This improvement, used to this day in most British inside cylinder engines with slide valves, was due to R. Stephenson and Co.

This type of passenger engine was built for

various railways at home and abroad until the end of 1845. A similar but larger engine by Kitson Thompson and Hewitson, 1845, for the Midland Railway—*The Engineer*, November 23rd, 1923—had 5ft. 6in. driving wheels, 15in. by 22in. cylinders, 11ft. 3in. total wheel base, boiler barrel 13ft. long by 3ft. 5in. diameter, 123 tubes $1\frac{1}{4}$ in. diameter, which gave a heating surface

by Longridge, 1846, was illustrated in *The Engineer* of January 21st, 1921, page 69. A North Midland engine, No. 71, of this type, built in October, 1842, by Stephenson, was the first locomotive to be fitted with link motion and three others for the same railway had Dodds' wedge motion. Drawings are given by Warren, pages 364 and 369.

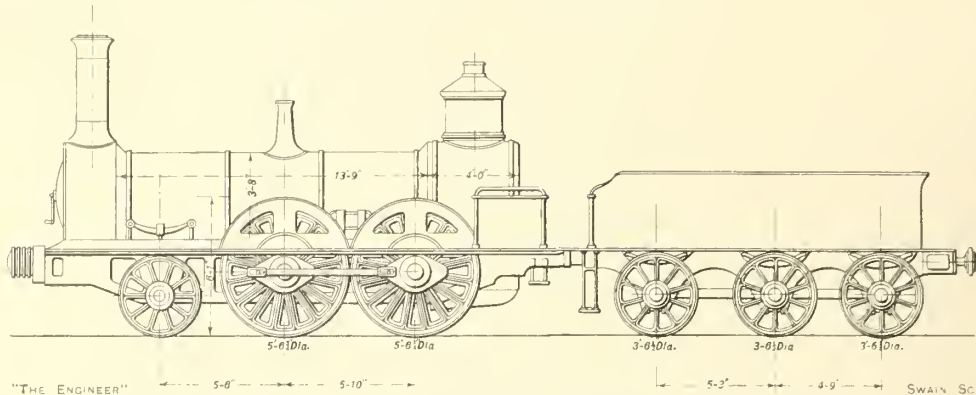

FIG. 56—BRISTOL AND BIRMINGHAM RAILWAY ENGINE, VULCAN FOUNDRY, 1846

of 799 square feet; total heating surface 874 square feet, weight 21 tons 7 cwt. Experiments made upon this engine showed the smoke-box temperature to be about 600 deg. Fah., with the steam temperature at about 312 deg. (G. P. Bidder before the Gauge Commissioners, 1845). The steam temperature corresponds to a gauge pressure of about 65 lb.

Interesting examples were two passenger engines by the Vulcan Foundry, 1846, for the Bristol and Birmingham Railway—Fig. 56—with 5ft. $6\frac{1}{4}$ in. driving wheels, 16in. by 22in. cylinders, and 1117 square feet of heating surface. The deep inside solid plate frame, Stephenson's type of T iron wheels, the balance weights, and the inside framed tenders are features of special interest.

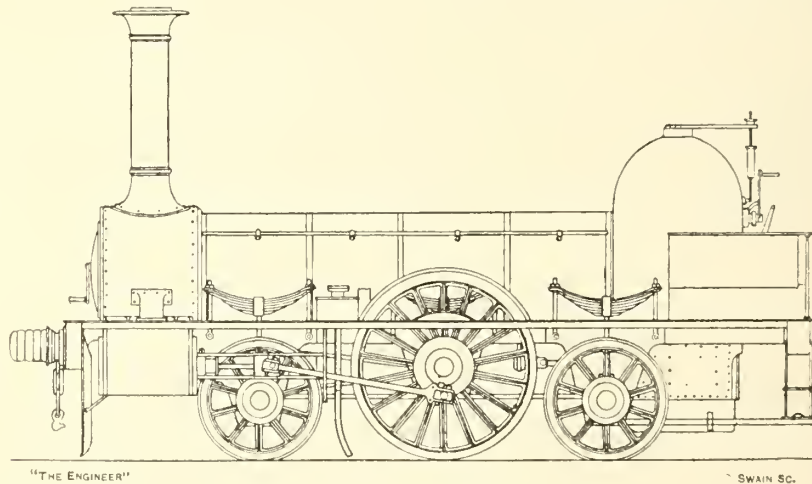

FIG. 57—STEPHENSON'S OUTSIDE CYLINDER LONG BOILER ENGINE, YARMOUTH AND NORWICH RLY., 1844

In 1842 the long boiler was applied to 2-4-0 goods and mixed traffic engines, also with inside cylinders and inside plate frames. These were built by Stephenson, Kitson, Longridge, and the Vulcan Foundry until 1846, though a few continued to be built by the first-named firm until 1860. Messrs. Stephenson supplied their drawings to other firms building the patent engines, and a 2-4-0 engine of Stephenson's early design built

Before dealing with the six-wheels coupled long boiler engines, the first of which came out in May, 1843, it is more convenient to complete the account of the 2-2-2 and 2-4-0 passenger engines. In 1844 Messrs. Stephenson constructed a new type of 2-2-2 engine with outside horizontal cylinders at the front—Fig. 57. As in the preceding engines, the bearings were inside and the driving wheels were without flanges. The first,

built for the Yarmouth and Norwich Railway, had 5ft. 6in. driving wheels and 14in. by 22in. cylinders. Later engines of 1845 had 15in. by 22in. cylinders. A number were built to Stephenson's drawings for the Brighton, Croydon, and Dover Joint Committee by Nasmyth and Co. One of the class "White Horse of Kent," which figured conspicuously in the evidence given before the Gauge Commissioners, had a short wheel base of 10ft. 3 $\frac{3}{4}$ in., boiler barrel 12ft. 6in., and fire-box casing 3ft. 8in. long. Total heating surface 893 square feet, of which the fire-box contributed 55 square feet. Grate area 9 square feet.

Although the design solved the boiler problem to some extent, the long overhang at each end introduced a serious defect from the standpoint

as implied by Daniel Gooch, for the gauge experiments. This, and many built in 1846, retained the "Gothic" form of fire-box casing, but later engines, as in Fig. 58, which represents a Stephenson engine of 1847 with 6ft. 6in. driving wheels for the L. and N.W.R (Southern Division), had ordinary raised fire-boxes. Features common to all of them, as built by Stephenson, Jones and Potts, and Tayleur, were the flangeless middle pair of wheels and the long-forked connecting-rods.

The L. and N.W.R. 7ft. engines, the largest of the type, had 15in. by 24in. cylinders, 3ft. 10in. carrying wheels, and wheel base 13ft. Heating surface of tubes 875 square feet, of fire-box 64.4 square feet, total 939.4 square feet. Grate area

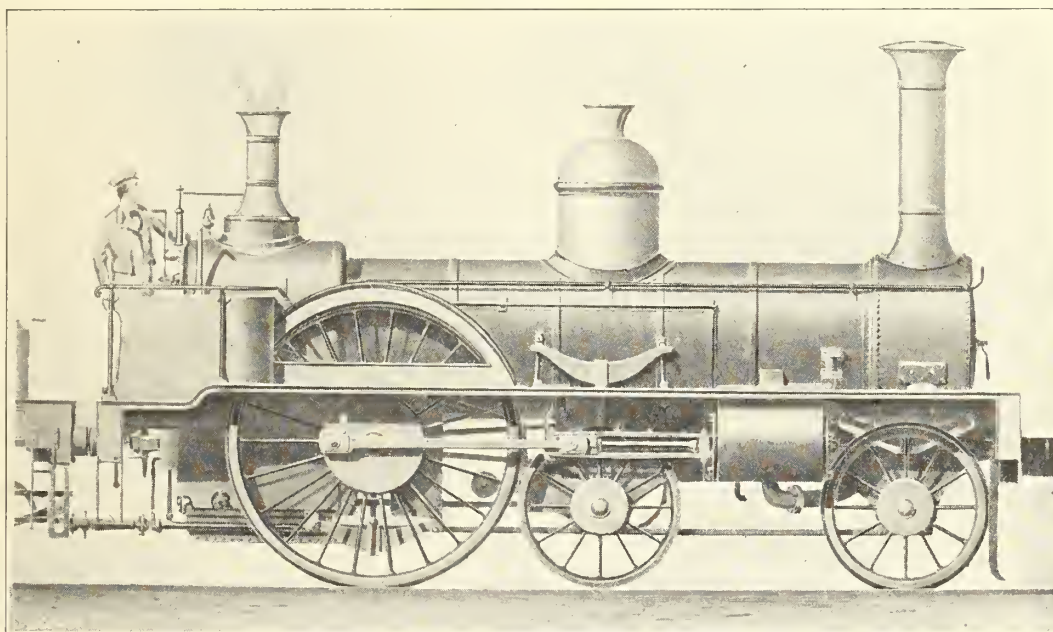

FIG. 58—L. AND N.W. RLY. LONG BOILER ENGINE—R. STEPHENSON AND CO., 1847

of stability, more especially in the outside cylinder type, in which lateral swaying was very pronounced at speeds of over 35 miles per hour. This defect was aggravated by the lack of balance weights, for these earlier engines do not appear to have been provided with them. Messrs. Stephenson, therefore, introduced a third type of "long boiler" passenger engine in 1845, in which the driving axle was placed immediately in front of the fire-box, thereby allowing the outside cylinders to be placed further back towards the middle of the engine, as in Fig. 58. A number of these engines had large driving wheels 6ft. 6in. diameter, including the first of the type, which was built in October, 1845, for the Great North of England Railway, and was the engine "A" tested by the Gauge Commissioners. Warren (page 386) points out that the drawings for this engine were approved by R. Stephenson in April, 1845, and therefore that it was not intended,

11.45 square feet. Weight in working order 24 tons 4 cwt., of which 13 tons 1 $\frac{1}{2}$ cwt. were available for adhesion. Some of the Jones and Potts engines with 6ft. 6in. wheels had larger heating surface, 1023 square feet total, and weighed 25 $\frac{1}{4}$ tons, but their wheel base was only 12ft. The 13ft. base engines were the better, since those with 12ft. base were by no means steady at high speeds, and there were cases of derailment. Engines of this type were constructed until 1849 for British railways, but the last four were made by R. Stephenson and Co. in 1855 for Egypt, where they lasted on local trains until 1900-1902. They had 6ft. driving wheels, 14in. by 22in. cylinders, and the leading and middle springs were connected by compensating levers. Their British sisters had nearly all disappeared before 1870, but engines of this type were in service in Belgium up to 1908 (see *The Locomotive*, Vol. XIV., page 142).

The 2-4-0 type underwent similar changes in

design, and during 1845-9 many were built with outside cylinders, and the usual long overhang at each end. The coupled wheels were generally 5ft. 6in. diameter, but a number on the York, Newcastle and Berwick and the Eastern Counties railways had 6ft. wheels. On the former line and on the York and North Midland Railway many subsequently had the 6ft. driving wheels removed, and 5ft. 2in. to 5ft. 6in. driving wheels substituted. The cylinders varied from 14in. and 15in. diameter by 22in. stroke to 15in. diameter by 24in. stroke. The driving wheels in all cases were without flanges.

In spite of its defects for fast traffic, the type for a few years was much in demand and was built not only by Stephenson, but by Kitson, E. B.

It cannot be said that the long boiler passenger engines were a success. The boilers were certainly more efficient than those with the very short tubes previously used, but this gain was offset by the unsteadiness of the engines, even to the extent of dangerous oscillation. The boilers themselves suffered in that the trailing overhang necessitated short fire-boxes and restricted grate areas. With small grates and long 1½in. to 2in. tubes, small blast pipes were necessary, though many engines of that day, even with short boilers, suffered from these defects. Coke was the fuel used, and therefore the very small fire-box was practically possible, but would not have been so had coal been burnt. But in criticising the engines, other circumstances must be taken into consideration. The

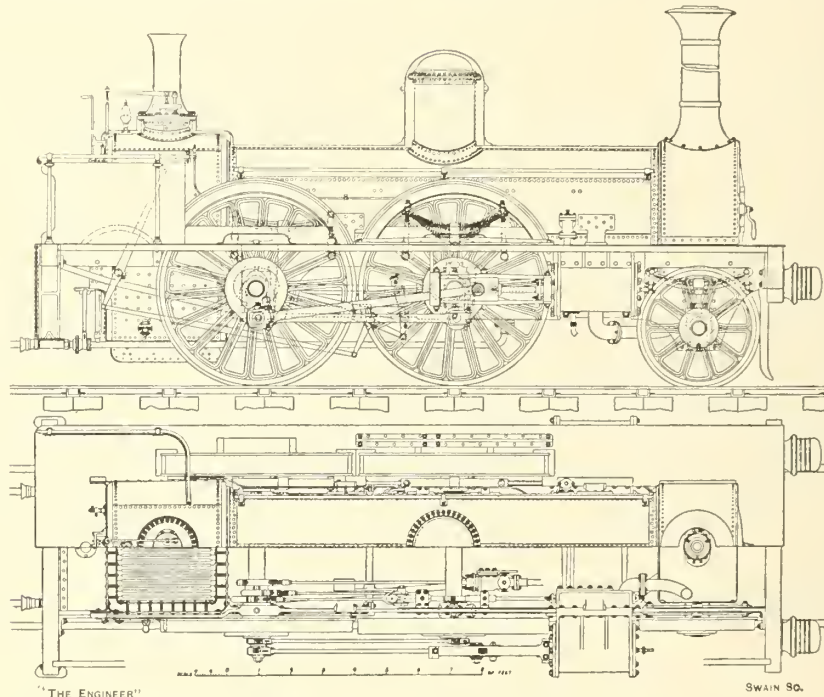

FIG. 59—YORK, NEWCASTLE AND BERWICK RAILWAY ENGINE—R. STEPHENSON & CO., 1848

Wilson, Jones and Potts, B. Hick, Tayleur, Sharp Bros., and Gilkes, Wilson of Middlesbrough. Those by Sharp were chiefly exported to Germany, mostly with 4ft. 6in. coupled wheels for goods traffic. They were copied by Borsig and several other firms, and for many years remained the standard goods engines in that country.

There were also a few 2-4-0 passenger engines by Messrs. Stephenson, in which the cylinders were brought back to a position behind the leading axle, and the connecting-rods drove the trailing axle placed in front of the fire-box—Fig. 59.² This type appeared in 1848, though only a few examples ran in this country, on the York, Newcastle and Berwick Railway. They anticipated some later well-known French designs.

² Fig. 59 is reproduced from "A Century of Locomotive Building" by permission of R. Stephenson and Co., Ltd.

relation of wheel base to turntables has already been mentioned. There was also the important question of balancing, which was then but imperfectly understood. This subject will be mentioned subsequently, but it may be added that a few of the long boiler engines had part of the revolving masses balanced by extensions of the wheel bosses. There does not appear to have been any reciprocating balance, without which such engines were bound to behave badly at any but very moderate speeds. On one railway, the Eastern Counties, on which better methods of counterbalancing had been introduced by Fernihough, the long boiler engines generally appeared to give tolerable satisfaction, seeing that they remained in service on that line much longer than elsewhere. After about four years' service on the Midland, all the long boiler passenger engines were radically

reconstructed with new frames, inside cylinders, and trailing axles behind the fire-box, only the boilers, cut down in length, being used again.

On the other hand, on certain French railways, such as the P.L.M. and Paris-Orleans, the long

Passenger Engines.—Before leaving long boiler passenger engines, a type with inside cylinders—Fig. 60—built by Alfred Kitching, of Hope Town Foundry, Darlington, in 1848, for the S. and D.R., deserves mention. It differed from Stephen-

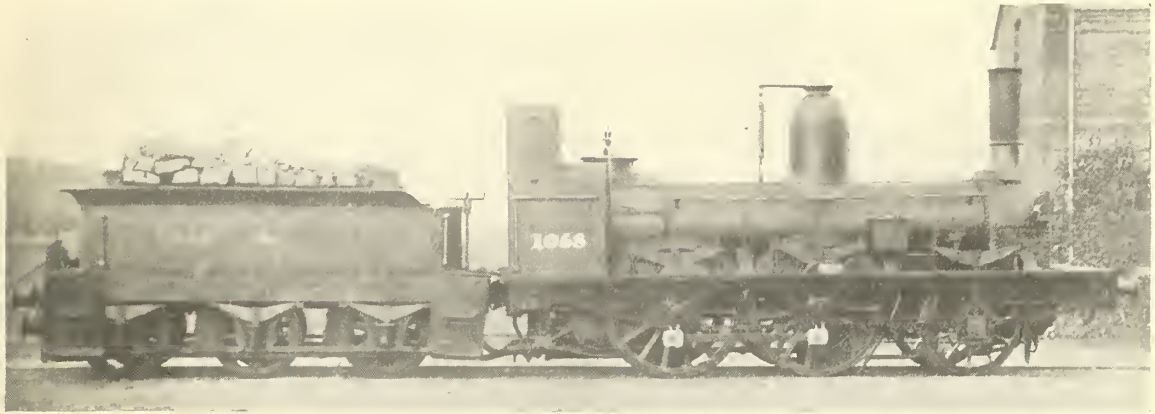

FIG. 60—ALFRED KITCHING'S STOCKTON AND DARLINGTON RLY. ENGINE "WOODLANDS," 1848

boiler 2-4-0 was for a long time the standard express engine, and many were built until 1873 with 6ft. 6in. coupled wheels and wheel base 13ft. 1in. long. French speeds at that time were considerably lower than those in this country; nevertheless, the use of such engines showed that

son's designs in that both inside and outside frames were used. The cylinders were 14in. by 20in.; coupled wheels, 5ft. 2in.; and leading wheels, 3ft. 8in. diameter; wheel base, 11ft. 2½in., of which only 5ft. 4in. separated the coupled wheel centres; the weight was 24 tons 13 cwt. in

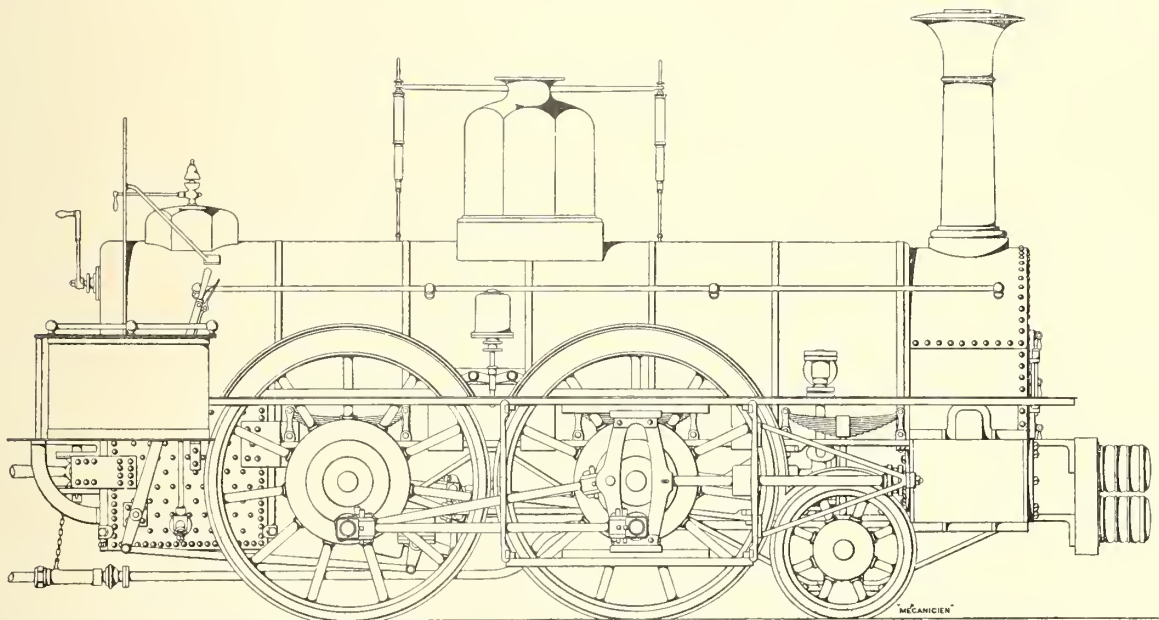

FIG. 61—2-4-0 PASSENGER ENGINE, No. 38, "ROKEBY," STOCKTON AND DARLINGTON RLY., 1847

proper balancing improved the type considerably. After 1873 they were gradually converted to the 2-4-2 type by the addition of a trailing axle behind the fire-box.

Stockton and Darlington Railway Long Boiler

working order, and the remarkably high boiler pressure of 120 lb. was carried.

The S. and D.R. passenger engines designed or built at Shildon were not very successful, unless the small 2-2-2 engine, "Meteor," No. 50—Fig.

51 *ante*—be excepted, and it was only when Messrs. Kitching came to the rescue, with the "Woodlands" class just mentioned, that a passenger engine suitable for the requirements of the line came into being. Kitching's type, with larger cylinders, 15in. by 20in. and 16in. by 19in., was built until 1860.

Amongst the Shildon-built engines were two curiosities, the "Rokeby" and "Ruby," illustrated by Fig. 61. They came out in 1847, and were of the 2-4-0 type, with 6ft. driving wheels and outside cylinders, 14½in. by 24in. The connecting-rods drove the trailing pair of coupled wheels, and the coupling-rod pins in the front pair worked in a slotted "crosshead," to which the connecting-rod was attached. This arrangement was subsequently suggested by Professor Redtenbacher in Germany.

Long Boiler Goods Engines, Six-wheels Coupled.—Whatever the demerits of the passenger engines, the long boiler 0-6-0 goods engines were an undoubted success. The inside cylinder type—Fig. 62—was brought out by Stephenson in 1843, when two engines were built for the York

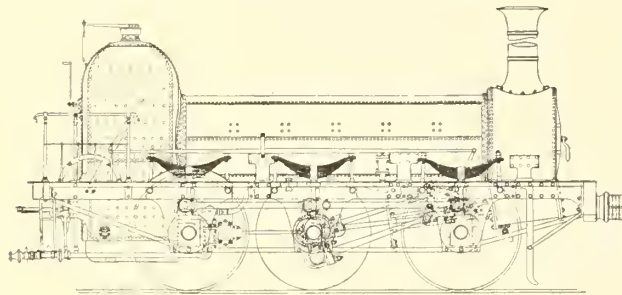

FIG. 62—STEPHENSON'S GOODS ENGINE, 1843

and North Midland Railway, followed by one for the Midland Railway in 1844.

Apart from the long boilers, in these engines we meet for the first time with inside cylinders and six coupled wheels combined with inside plate frames; moreover, the cylinders were inclined downwards to enable the slide bars to be placed above the leading axle, replacing the clumsy method which prevailed up to that time of arranging them beneath this axle.

From 1843 to 1860 a very large number of these engines were built by most British locomotive firms for all railways. Being used for slow-speed traffic, they did not suffer from the swaying defect of the passenger engines, more especially since the cylinders were inside, and they also had the advantage of being able to negotiate sharp curves into yards and sidings. In most of the early engines, the driving wheels were flangeless, though in later engines thinned flanges were added. The early engines, 1843 to 1847, had Gothic type fire-boxes, but subsequent engines were provided with ordinary round-topped fire-boxes. The cylinders were generally 15in. by 24in., the coupled wheels

varied from 4ft. 6in. to 4ft. 9in. diameter, and these remained standard dimensions until 1852, when 16in. cylinders and 5ft. wheels came into use. The wheel base was generally about 11ft. in the early engines, and the boiler barrels were about 12ft. 6in. long. The total heating surface varied from 770 to 870 square feet, but the firebox was necessarily restricted in length, and provided about 60 square feet of the above amount with a grate area of 10½ square feet. The pressure in the first engines was about 80 lb., but had been increased to 100 lb. in some of the 1848 engines.

Some railways, notably the N.E.R., including the S. and D. section, continued to build inside cylinder 0-6-0 engines, with all wheels in front of the fire-box, until 1875, and at a still later date Beyer, Peacock exported them to New South Wales. These later engines were considerably larger, with 17in. and 18in. cylinders, and in addition to the facility with which they traversed sharp curves, W. Bouch considered that the extra area of water surface enabled them to carry the water better without priming. After Messrs. Stephenson had supplied several in 1846-7 to the Paris-Orleans and Marseilles-Avignon railways, they became a standard type in France, where they were known as the "Mammoth" class. Many are still at work in that country.

Two interesting inside cylinder long boiler 0-6-0 engines were built in 1844 by B. Hick and Son. A sectional elevation of these was given in *The Engineer* of July 30th, 1920, page 103. They had bar frames and Bury type fire-boxes. The cylinders, as was usual in all six-coupled engines, except those by Stephenson mentioned previously, were inclined upwards. The boiler was rigidly fastened to the bar frames by brackets placed immediately above each axle. The design was suggested by Kearsley, locomotive superintendent of the Midland Counties Railway.

The 0-6-0 Engine with Outside Cylinders.—The 0-6-0 engine with outside cylinders has never been liked in this country. The earliest examples were built at the Shildon Works of the S. and D.R. in 1847 by W. Bouch. There were only three of the class—Fig. 63—which, like most S. and D. engines, presented special peculiarities. The cylinders, 16in. by 24in., were horizontal, the coupled wheels, 4ft. diameter, were of cast iron, the centres, unlike Hackworth's plug wheels, being in one piece. The total wheel base was only 8ft. 8in., and there was necessarily a very big overhang at each end, so that the leading wheels carried a weight of 10 tons 5 cwt. and the drivers only 8 tons 11 cwt., of a total of 25 tons 11 cwt. The connecting-rods were placed next to the wheels, with the coupling-rods outside, and to allow them to clear the pins they were made with a large circular eye opposite the leading wheel. To accommodate this eye, the two slide bars were spaced vertically 2ft. 6in. apart. The steam chests were inside, but instead of working the valves in a straight line from the excentrics, horizontal

rocking levers were provided with a fulcrum on the centre line of the engine. The excentric rods were coupled to the ends of the levers, and the valve spindle on each side was connected to a point between the fulcrum and the excentric rod connection. A diagram of this gear was given in *The Engineer*, October, 1875. The boiler was large

Banking Engines.—During this period heavy tank locomotives for assisting trains up inclines made their appearance. For the Lickey incline J. E. McConnell converted some of the Norris American tender engines into saddle tank engines, and in June, 1845, built at Bromsgrove a heavy six-wheels coupled saddle tank engine, the "Great



FIG. 63—W. BOUCH'S STOCKTON & DARLINGTON RLY. ENGINE "COMMERCE," BUILT AT SHILDON, 1847

but badly proportioned. It was 13ft. 10in. long by 4ft. diameter, but contained only 107 tubes, 14ft. 2in. long, and the total heating surface was only 826 square feet. The pressure was 80 lb., and the grate area 10 square feet only. These peculiar engines were fitted with steam brakes.

The only other outside horizontal cylinder six-

Britain," for this special service. Unfortunately, no illustration of this locomotive, at that time the most powerful in the country, is known to exist, but the following particulars were given in the Gauge report:—Cylinders, outside, 18in. by 26in., placed at 6ft. 2in. centres; six coupled wheels, 3ft. 9in. diameter; wheel base, 6ft. 9 $\frac{1}{2}$ in. +

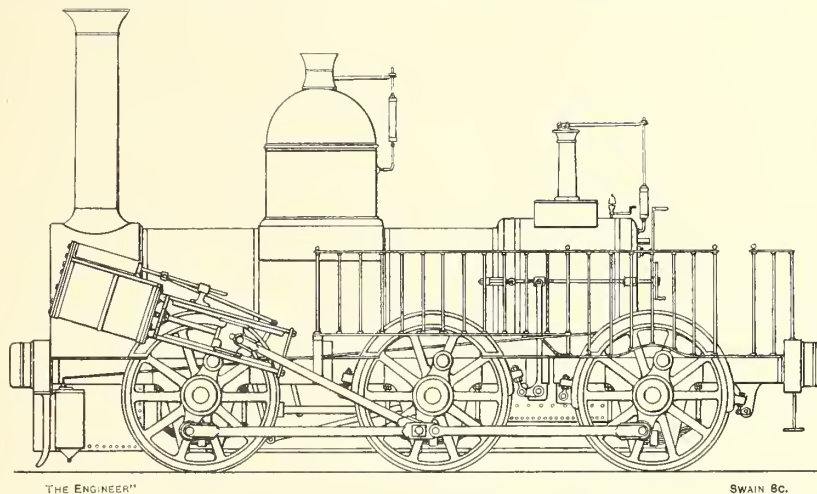

FIG. 64—PATON'S BANKING ENGINE, EDINBURGH AND GLASGOW RLY., BUILT AT COWLAIRS, 1844

coupled locomotives of importance consisted of thirty-nine engines built in 1874-7 for the Caledonian Railway, which will be mentioned subsequently.

The long boiler engine of this type found a home on the Continent, where it was the standard goods engine in all countries for many years.

6ft. 11in.; boiler, 12ft. long, of oval section, 3ft. 10in. vertical, 3ft. 9in. horizontal diameter; 134 2in. tubes, 12ft. 6in. long; the weight was 30 tons, of which 12 tons were carried on the middle and 9 tons on each of the other axles. As the height of the lower edge of the cylinders was only 2ft. above rail level, these must have been

attached to the frames below the smoke-box without the steep inclination which was the fault of so many engines at that time. As the fire-box casing was 4ft. 4½in. wide, the inside frames cannot have been extended to the back buffer beam, though what arrangement was made for the trailing bearings is not known. The water was carried in a saddle tank, 11ft. 9in. long. It was stated by Mr. McConnell that this engine had taken a gross lead of 135 tons up the incline of 1 in 37 at 8 to 10 miles per hour.

The other banking tank engines—Fig. 64¹—were built at the Cowlairs Works of the Edinburgh

“Samson,” were constructed. The inclined outside cylinders were 15½in. by 25in., and the wheels 4ft. 3½in. diameter. The steam chests were above the cylinders and the valves were driven from eccentrics on the driving axle through the intermediary of rocking shafts. The driving wheels were supplied with brake blocks actuated by levers and screw, but the trailing wheels were provided with a steam brake, the cylinder of which was placed underneath the footplate above the axle. Sand boxes were placed near the front buffer beam, and to clean the rails hot water jets were used, similar in principle to the arrangement previously

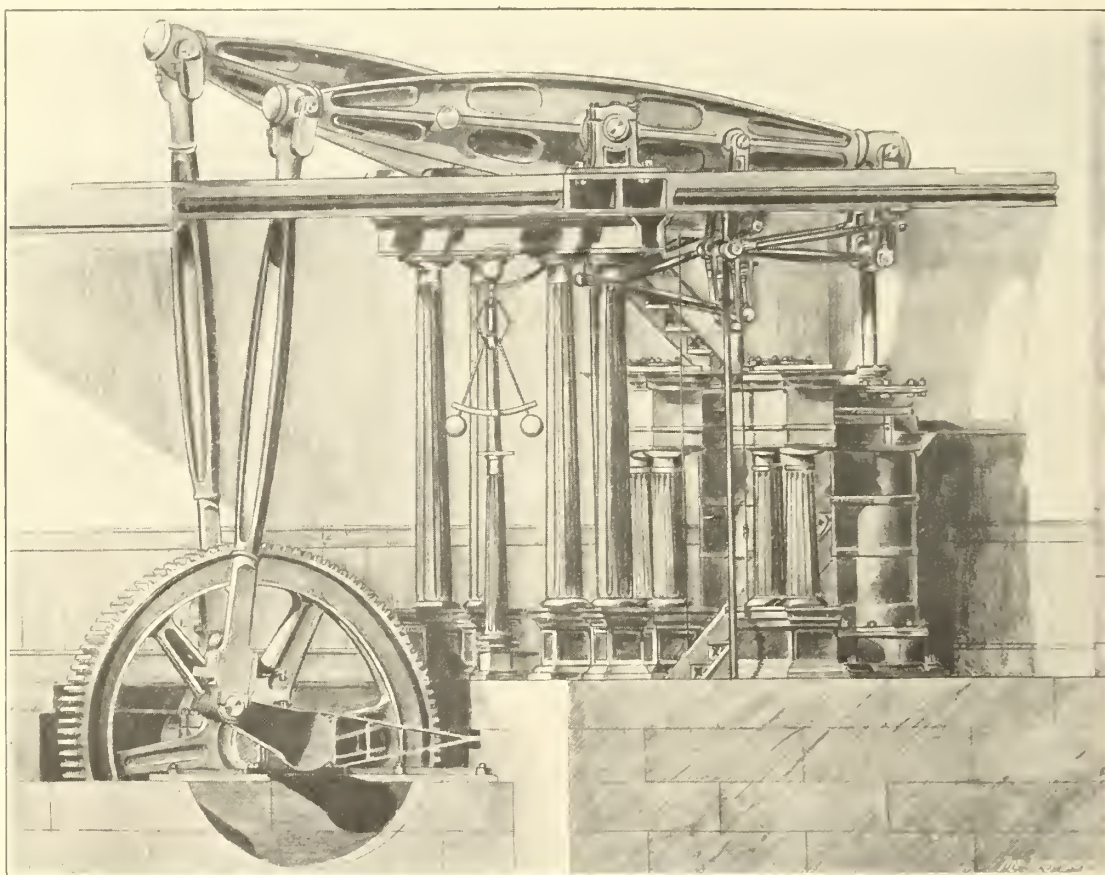

FIG. 65—STATIONARY ENGINE FOR WORKING THE COWLAIRS INCLINE, BUILT BY NEILSON & CO., 1842

and Glasgow Railway in 1844 to the designs of Mr. Paton for working the steep incline from Glasgow (Queen-street) to Cowlairs. This incline had been worked by rope haulage with the large double beam stationary engine built by Neilson and Co. in 1842, shown by Fig. 65. This engine worked the endless wire rope, which was attached to the front of ascending locomotives, for a period of more than seventy years. Mr. Paton, the locomotive superintendent, determined to try locomotives, of which two, “Hercules” and

used by Melling on the Liverpool and Manchester Railway. The well tanks were placed under the smoke-box, and had a capacity of only 200 gallons. The engines weighed 26½ tons. They were used on the Cowlairs incline for only three or four years, and appear to have been discarded on account of the emission of smoke in the tunnel and damage to the masonry, though it was also stated that they broke a number of rails. Subsequently, a return was made to the rope haulage system.

¹ Fig. 64 has been drawn from an illustration supplied to the RAILWAY MAGAZINE, 1898, by Mr. John Conacher, then general manager of the North British Railway.

Balancing and Balanced Locomotives.—The subject of balancing locomotives was frequently

mentioned before the Gauge Commission of 1845. At an early date, as speeds increased, it was seen that a balance for the revolving masses was necessary, and in 1837 several engineers, such as Sharp Roberts and Braithwaite and Milner, the latter firm on the Eastern Counties Railway, applied weights in the driving wheels. In 1840 Thomas Hunt, then locomotive superintendent of the North Union Railway, placed weights embracing two spokes in the driving wheels of the four-wheeled Bury locomotives on that line. These weights were placed opposite each crank and in most cases they were formed by extensions of the wheel bosses. The writer does not know

be mentioned later, were subsequently built in 1845 on this principle.

In 1839 Heaton of Birmingham proposed to balance the reciprocating masses by means of bob weights, which involved a connecting-rod, heavy crosshead and slide bars on the opposite side of the crank—see *The Engineer*, January 30th, 1880, page 77—and it was stated that an engine was fitted with this arrangement. It was applicable only to outside cylinder engines, and proved too complicated, though the steadiness of the engine was improved.

T. R. Crampton pointed out in the *Railway Times*, 1842, that the cause of oscillation of a

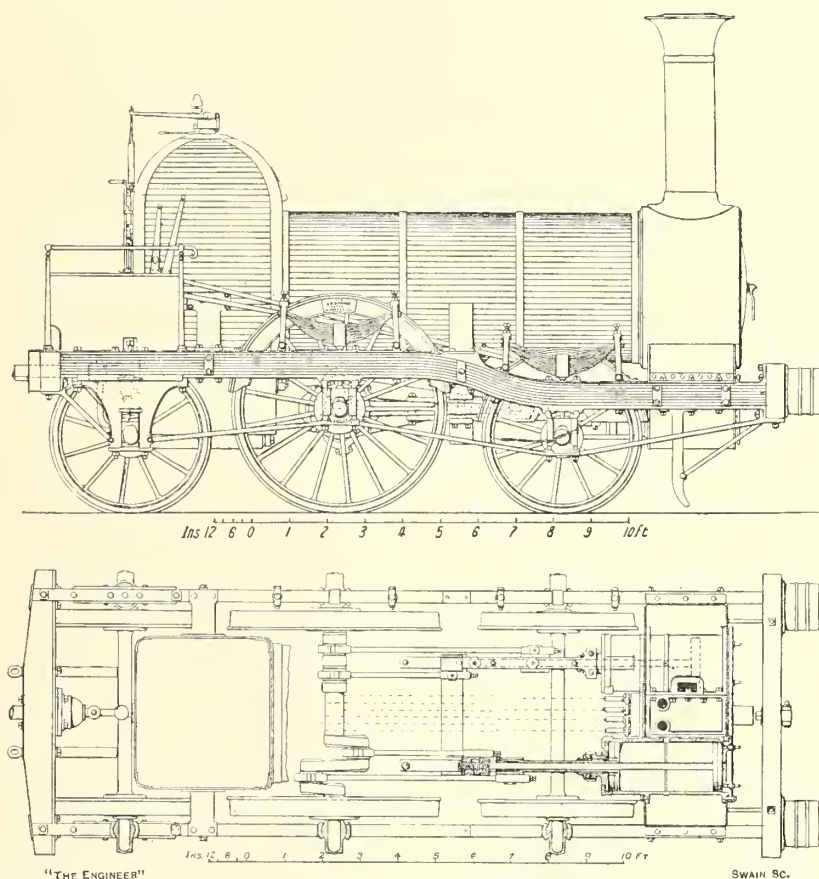

FIG. 66—JOHN G. BODMER'S BALANCED ENGINE, FOR THE SOUTH-EASTERN AND BRIGHTON RLYS., 1845

whether any of the above engineers placed the weights in the rims, but the 0-6-0 goods engines by John Gray for the Hull and Selby Railway—Fig. 50 *ante*—certainly had such weights in 1844, if not earlier.

The first engineer who appears to have seen the necessity for balancing the reciprocating masses was John G. Bodmer, a Swiss who settled in Bolton, and afterwards built a few locomotives in Manchester. In 1834 Bodmer took out a patent for two pistons moving in opposite directions in the same cylinder. Two locomotives, which will

locomotive was not the steam pressure, but the unbalanced reciprocating masses. In the first Crampton engines of 1846 these were balanced by weights in the bosses of the driving wheels.

The unsteadiness of some of the long boiler passenger engines, especially those with outside cylinders and middle driving wheels, drew further attention to the subject. R. Stephenson before the Gauge Commissioners stated that some outside cylinder engines had more "yawing"—*i.e.*, swaying—motion than he liked, and he gave the same reason as that previously given by Crampton.

But the long boiler 2-2-2 engines of 1845, the "White Horse of Kent" class on the S.E.R.—similar to Fig. 57 *ante*—according to General Pasley's evidence before the Commission, were without balance weights.

W. Fernihough, locomotive superintendent of the Eastern Counties Railway, appears to have been the first to use weights in the rims of the wheels, heavy enough not only to balance the revolving masses, but also the pistons and other reciprocating masses. He informed the Gauge Commission that the engines so fitted were "infinitely more steady afterwards." Perhaps the most interesting portion of his evidence was the prophecy of the multi-cylinder uncoupled engine of the Webb and first de Glehn types of 1882-86, as follows:—"It is possible to make one pair of cylinders working on one pair of driving wheels, and another pair of cylinders on another pair of driving wheels, because coupled engines have great disadvantages for passengers at high speeds." Subsequently, in 1849, Le Chatelier published the theory of balancing, which laid down the rules practised by D. K. Clark and those who followed him.

Bodmer's Locomotives.—Bodmer's two balanced locomotives of 1845 were built for the South-Eastern and Brighton Railways, and are illustrated in Fig. 66.² The driving wheels were 5ft. 6in. diameter and the cylinders 16in. diameter, with an equivalent stroke of 30in., each of the two pistons having an actual stroke of 15in. The arrangement is shown in the plan view. The two pistons moved in opposite directions, the piston-rod of the front one working inside a tubular rod to which the back piston was attached. The two connecting-rods on each side worked on cantilever gudgeon pins fixed on the right and left of their respective crossheads, and the crank axle was a complicated forging with two throws on each side at 180 deg. with each other, but at 90 deg. with the two throws on the opposite side. The axle journals worked in brasses which had spherical bearings in the bodies of the axle-boxes, and the latter had oil instead of grease lubrication. The reversing was effected by a special form of Stephenson link motion, but expansion was produced by a form of Meyer slide valve, the blocks of which were regulated by screw gear.

A defect in the design was the unequal length of the two connecting-rods on each side, the one for the front piston being very short. It is stated that Bodmer, to remedy this defect, got out a design in which the rods were of equal length, but no particulars are available. Bodmer used 95 lb. steam pressure. The South-Eastern engine does not appear to have done much work, but the Brighton engine ran until 1859, when it was reconstructed as an ordinary engine with new 15in. by 20in. cylinders.

² For full particulars and details of Bodmer's locomotives with illustrations from original drawings, see *THE ENGINEER*, March 5th, 1909, also *THE LOCOMOTIVE*, Vol. XV. (1909), pages 10, 56, 110.

Constructional Details.—The question of inside *versus* outside cylinders assumed considerable importance during this period. Some locomotive engineers, such as B. Cubitt and W. Fernihough, found that the driving axle-boxes of outside cylinder engines then required more attention than those of inside cylinder engines, and after having been out of the shops a few weeks, axle-box wear caused additional oscillation in the former. Gray was also strongly in favour of inside cylinder engines. R. Stephenson, who built many outside cylinder engines at this time, stated in 1849 (*"Proc.," Inst. C.E.*) that after years of experience he was inclined to regret their use. But Joseph Locke, prompted by experience of broken crank axles on the Earlestown curves of the G.J.R., was a staunch advocate of outside cylinders. In regard to crank axles, difficulties in their manufacture were being overcome in this country and a better axle resulted. R. Stephenson advocated outside cylinders for foreign railways on the grounds that it was then difficult on the Continent to make a good crank axle.

Bogies were considered unsafe at high speeds, and, except upon the American type engines of the Birmingham and Gloucester Railway, were not used on any main line. The objection of British engineers was due to the short bogie wheel base, then only about 3ft., as a result of which and the absence of a suitable centre plate, it was feared that they would tend to set themselves across the track. Fernihough, indeed, in 1845, proposed a large bogie plate or ring to oppose frictional resistance to this action, but it was about fifteen years later before this idea was adopted.

Wheels were generally made with cast iron bosses, but solid round spokes had displaced the old tubular form, which, when cast in, subsequently worked loose in the boss. By splitting and opening the ends of the solid spokes before casting the boss round them, a firmer job resulted. The outer end of each spoke was welded to a piece of flat iron bent into a segment of proper length, and after the boss had been cast on, the segments were welded together to form the rim. Occasionally wrought iron rings were shrunk on the bosses.

Bury's wheels had solid wrought iron spokes with conical ends which were keyed into holes bored in the cast iron naves. The outer ends had forged T heads riveted to a wrought iron rim about 1in. thick.

Many of Stephenson's wheels of the 1843 to 1848 period were made as in Fig. 57 *ante*, with cast iron bosses, the spokes and rim being formed of T irons placed back to back and bent round. The triangular spaces between each spoke and the tire were tightly wedged with oak pieces. This form of wheel was also used by Tayleur and by Jones and Potts in the "long boiler" engines built by them.

Solid wrought iron wheels do not appear to have been much used until a few years later. Colburn illustrates on page 47 of "*Locomotive Engineer-*

ing" a wheel of this type invented by John Day in 1835, which, after the patent had expired, became the standard wheel almost universally used from about 1847 onwards. Day's type of wheel was regularly made by John Dewrance from 1840 to 1845 at the Edge Hill shops of the Liverpool and Manchester Railway. When these wheels were first made it is very doubtful whether a Nasmyth steam hammer was available. The cast iron wheels designed by Sharp Bros. in 1846 for heavy goods engines may be mentioned here. These were of channel section with a T-shaped circular rib round the wheel at about 13in. from its centre. The spokes between this rib and the rim were of T section. The engines will be mentioned subsequently; the wheel is illustrated in D. K. Clark's "Railway Machinery," page 214. Still earlier cast iron wheels with spokes of H section, similar to Webb's design, were made in 1840 in the shops of the Dublin and Kingstown Railway—see *The Engineer*, June 24th, 1898.

Tires were of wrought iron welded at the joint, and before 1838-40 were shrunk on without other fastening. About this time it was found necessary to use additional means for securing them and rivets through the wheel rims were introduced.

According to the late W. P. Marshall, D. Gooch in 1840 on the G.W.R. added a steel bar to the pile from which the tire was rolled. This was worked in to form the tread of the tire, which had to be faced by grinding, since it was too hard to be turned after having been chilled by shrinking on the wheel centre. W. P. Marshall was one of R. Stephenson's assistants, for two years, 1840-1842, locomotive superintendent of the North Midland Railway, and afterwards the first secretary of the Institution of Mechanical Engineers. He had first-hand knowledge of early locomotive developments. In "A Story of Railway Pioneers," by Snell, the credit for steeled faces on locomotive tires is given to Isaac Dodds, who with Jessop, of Sheffield, worked out a process for a rim of steel on an iron tire by continuous welding during the passage of the bar through the rolling mill. The date given for this process is about 1850, so that Gooch must have anticipated it by several years.

On the Liverpool and Manchester Railway John Dewrance is stated to have forged the eccentric sheaves solid with the crank axle.

The most important improvement during this period was the Williams-Howe link motion brought out by R. Stephenson and Co. in 1842. The first locomotive fitted with it was "North Midland No. 71," a 2-4-0 long boiler goods engine which came out on October 15th, 1842.

The wedge motion by Isaac Dodds was patented in 1839 and tried on an engine of the Sheffield and Rotherham Railway, and subsequently applied in 1842 to three engines on the North Midland Railway. In the earliest engine Dodds used the wedge eccentric for reversing only, a second eccentric with expansion valve being

added. Subsequent modifications enabled the wedge motion to be used also as an expansion gear, and a single eccentric was employed provided with a double wedge. When the wedge was moved by levers along a square section of the axle it acted upon corresponding inclines inside the sheave, so that the latter was moved transversely across the axle. The gear as improved by Henry Dubs was fitted to a number of engines built by the Vulcan Foundry, 1852-5, for South Wales, Ireland and India. Its last application was to passenger and goods engines for the North Staffordshire Railway in 1871-2 under the superintendency of the inventor's son, T. W. Dodds. The gear was simple, but had the defect that the wedges sometimes seized and rendered the gear immovable.

The Gooch stationary link motion appeared in 1843, and must have been first applied to one or more of the Great Western 7ft. singles, "Ixion" class, in replacement of the previous gab motion, since no new engines for this line were built between October, 1842, and February, 1846. The first new engine fitted with the new gear was John V. Gooch's L. and S.W.R. 6ft. 6in. express engine "Snake," turned out from Nine Elms Works, November, 1843. Almost all the G.W.R. broad-gauge engines, including the last three 8ft. singles built in 1888, had it, but on the standard gauge its use ceased with R. Sinclair's engines of 1866 for the G.E.R. and a few Caledonian engines of 1875. It had the defect of an angular drive between the eccentric and valve rods; nevertheless it was employed on the Continent to a much greater extent and to a considerably later date than in this country.

J. V. Gooch from 1843 used double ported slide valves on all his L. and S.W.R. engines. The second steam inlets were channels through the body of the valve, on the back of which was a cast iron plate fitted into the steam chest in such a way that it could be adjusted by screws as the valve wore down. There were ports through this plate which coincided with the channels through the valve during admission, but the plate closed the channels during exhaust. But the travel of the valve, which was $4\frac{1}{2}$ in., was, in spite of the double admission, only slightly less than the usual $4\frac{1}{4}$ in. to $4\frac{1}{2}$ in. Joseph Tomlinson, who was at one time under Gooch, stated that these valves gave much trouble, but the latter apparently thought them successful, for he took the design with him to the Eastern Counties Railway. These valves are illustrated in D. K. Clark's "Railway Machinery," plates 11, 12 and 27.

With the long boiler engine Messrs. Stephenson at the same time introduced the driving of short-stroke feed pumps from the back gear eccentrics, to which special lugs for the pump rods were attached. Stephenson's pumps and drive were afterwards used by D. Gooch, whose first engines had long stroke pumps, driven off the crosshead, also a short stroke hand pump, at the side of the

fire-box—Figs. 44 and 45. John V. Gooch, who also adopted short-stroke pumps, drove them from additional excentrics. The short-stroke pump itself was due to T. Hackworth.

Boilers still suffered from the effects of the low centre of gravity theory, and most engineers seemed willing to do anything rather than raise them. J. V. Gooch bulged in the plates to clear parts of the motion. In the same engineer's goods engines and in McConnell's Lickey banking engines the boilers were elliptical as in some of the earlier Liverpool and Manchester engines. It is a curious commentary on this latter practice that Major-General Pasley, then Chief Inspecting Officer of the Board of Trade, objected to oval boilers, not on account of their deviation from the circular section, but because he considered that the oval form necessitated a slight raising of the centre of gravity. It was not then appreciated that if the boiler were raised 2in. the centre of gravity of the whole engine would be raised approximately one-quarter to one-third of this amount.

Much improvement had been made in boiler construction. The number of longitudinal seams had in general been reduced to two, but these were, with few exceptions, lap jointed. The barrels, having greatly increased in length, were usually in three rings, the middle ring being the largest. In J. V. Gooch's L. and S.W.R. engines butt joints were used for the transverse seams with outer butt strips. Sharp's boilers of 1845 were

probably the best of the period. The rings were made of single plates with only one longitudinal seam, and the barrel was, like that of J. V. Gooch, parallel throughout, with planed transverse butt joints and outer butt strips. Some of these boilers after eighteen years' service on the Midland Railway showed none of the grooving in the barrel, so common at one time with transverse lap joints. The construction is shown in plates 19 and 20 of Clark's "Railway Machinery."

D. Gooch in 1845 tried corrugated copper plates to strengthen the flat sides of the fire-box, and J. V. Gooch used them in 1843 for the walls of the fire-box mid-feather partitions. Both brothers employed Venetian dampers in the smoke-box immediately in front of the tube plate to replace the chimney dampers previously used. Ashpan dampers appear to have been rarely used, ashpans open at the front being usual. John Gray employed iron in preference to brass tubes, being of opinion that they were better in chalky water districts.

Coal was burnt on the S. and D.R. in Hackworth's return flue boilers, but the few attempts to burn coal in ordinary fire-boxes at this time ended in failure owing to the emission of smoke and the complications which were thought essential. The subject of coal burning will be mentioned later, but for nearly thirty years subsequent to the opening of the Liverpool and Manchester Railway coke was almost the sole fuel.

Chapter VI—Locomotive performance to end of 1845

It is convenient here to give a few particulars of the work done by early locomotives down to the end of 1845, when the Gauge Commission was sitting. Locomotive performances formed a large portion of the evidence laid before the Commissioners, and ultimately led to the celebrated trials between the broad and narrow-gauge engines.

The Stockton and Darlington was a slow-speed coal-carrying railway. Pambour stated that the fuel consumed by the mineral engines was about 54 lb. per mile, or .86 lb. per ton gross per mile. He also gave a table showing that during five months, at the end of 1833, 23 mineral engines of all types performed work equivalent to 5,802,562 gross ton-miles on a level at a cost of .058 penny per ton-mile for repairs.

Of the passenger engines Whishaw, in 1839, timed two, the "Sunbeam," 2-2-0 type, by Hawthorn, and Hackworth's short stroke 2-2-2 engine "Arrow," the latter having the lever between piston and connecting-rods—see page 32. A maximum speed of 42.8 miles per hour was attained by the "Arrow" on the down journey from Shildon to Stockton, the average speed being 25.3 miles per hour. The weight of train was only about 8½ tons. The "Sunbeam," with 20½ tons from Stockton to Darlington, attained a maximum of 30 miles per hour, and an average of 16½ miles per hour with a strong side wind blowing.

The early 2-2-2 passenger engines of the Hull and Selby Railway consumed 33.6 lb. of coke per mile, or .84 lb. per ton mile, but Gray's engines "Star" and "Vesta," with the "horse-leg" expansion gear, were said to have burnt 14.9 lb. per mile, or .37 lb. per ton mile.

The most detailed information comes from the records of the Liverpool and Manchester Railway. Pambour's data of 1834 are analysed at some length in Colburn's "Locomotive Engineering," pages 34-37, but only four examples need be given here as a basis for comparison with later engines:—

The coke consumptions are net, when running only.

It is estimated that much steam was lost at the safety valves. Colburn calculated that the best L. and M. engines in 1834 consumed at least 10 lb. of best coke per indicated horse-power hour, and that probably 11 lb. to 12 lb. was nearer the actual consumption. But it must not be forgotten that there was no lap on the valves, and steam was admitted throughout the stroke. Cost of repairs per train mile rose steadily from 9.3d. in 1832 to 13.1d. in 1834.

Ed. Woods¹ stated that during 1838-9 the average coke consumption attained its maximum of about 49 lb. per mile—including lighting up and standing—for passenger trains averaging seven coaches, and 54 lb. with goods trains averaging 16 wagons. During 1839 John Gray's expansion gear was fitted to the "Cyclops," a passenger engine, with the result that its gross consumption dropped from 40.1 lb. to 32.4 lb. per mile, though in another part of the quoted paper 28.5 lb. is given. By altering the valves and giving them 1in. lap, and also by seeing that the firing was much more carefully done, the consumptions in 1840-1 for passenger engines averaged 22 lb. to 26 lb. per mile with seven coaches.

Between 1840 and 1845 practically the whole of the Liverpool and Manchester locomotives were completely renewed, and the standard passenger engines, with 5ft. wheels and 12in. by 18in. cylinders, burnt 14½ lb. to 18 lb. of coke per mile with seven coach—say, 50-ton—loads. The new 0-4-2 goods engines with 5ft. wheels and 13in. by 20in cylinders, consumed 21 lb. to 24¾ lb. per mile with average loads of 110 tons behind the tender.

The ton-mile consumptions of coke—Table II.—are taken from the Gauge Report and refer to the 18 months' period ending December, 1844. The entries in the last column are the writer's.

On the Grand Junction Railway there were only

¹ "Observations on the Consumption of Fuel and the Evaporation of Water in Locomotive and Other Steam Engines," published in Tredgold's "Steam Engine."

TABLE I.

Engine.	Type.	Diameter of driving wheels.	Cylinders.	Weight of engine.	Weight of tender and train.	Average pressure	Average speed throughout journey.	Coke per mile.	Water evaporated per 1 lb. coke	
"Vesta"	2-2-2	5ft.	11½in. x 16in.	Tons. 8.71	Tons. 33.15	lb. sq. in. 51	m.p.h. 27.23	lb. 26.0	lb. 5.34	Pass
"Leeds"	"	"	11in. x 16in.	7.07	88.34	54	18.63	30.4	6.68	"
"Fury"	"	"	"	8.2	48.8	57	18.63	27.3	7.3	"
"Atlas"	0-4-2	"	12in. x 16in.	11.4	195.5	53.7	9.72	54.1	5.18	Goods

two engines with four wheels coupled, and the goods trains, when heavy, were worked by two passenger engines. It was also the usual practice on the London and Birmingham Railway to employ two or more of Bury's four-wheeled 0-4-0 engines on the goods trains.

The comparative costs of operation of three of the best known standard gauge passenger locomotives of the 1844-5 period—see Table III.—are taken from B. Cubitt's evidence, and relate to engines running on the Brighton and Dover Railways. The engines were new at the first dates given.

One of the Stephenson type long boiler 0-6-0 engines with inside cylinders 15in. by 24in. and 4ft. 9in. wheels, built by Kitson and Co., was specially tested during four double trips on the

Great Western engines. The figures, which differed considerably, were of little or no value, being mostly obtained by the crude method of measuring the depth of the water in the tender with a stick. The initial temperatures appear to have been carefully avoided, and Gooch complained with reason that the narrow gauge party, represented by G. P. Bidder, heated the water from *outside* sources before starting. "Priming," to which many standard gauge engines of that day were somewhat prone, must have bulked largely in some of the results, and may account for Bidder's figures of 7.8 lb. of water on the broad gauge, as compared with 9.6 lb. on the narrow gauge per pound of coke burnt. The "standard" appears to have been "from and at any temperature obtainable at the start."

TABLE II.

Railway.	Passenger.		Goods.		Type of engine
	Average weight of trains.	Coke per ton-mile, pounds.	Average weight of trains.	Coke per ton-mile, pounds.	
Great Western (broad gauge)	67	.55	265	.27	Passenger, 2-2-2, 7ft. Goods, 2 4-0 and 0-6-0
Manchester and Liverpool ...	30	.56	100	.24	Passenger, 2-2-2, 5ft. Goods, 0-4-2, 5ft.
Grand Junction ...	43.5	.53	152	.33	Passenger and goods, worked by 2-2-2, 5ft. 6in. and 5ft.
London and Birmingham ...	42.4	.87	162	.43	Passenger, 2-2-0 Bury Goods, 0 4-0 Bury

Midland Railway between Derby and Rugby in 1845. With a load of 315½ tons behind the tender the coke consumption was 46.8 lb. per mile, or .16 lb. per ton-mile. On another occasion with 348¾ tons from Rugby to Leicester—20 miles—on which there is one rising gradient of 1 in 330, the average speed was 22 miles per hour. From Leicester to Derby—29 miles—with 290 tons the average speed was 25¾ miles per hour, the gradients being easy. The coke consumption over the whole journey was 48 lb. per mile, or .153 lb. per ton-mile.

Much evidence was given before the Gauge Commission in regard to evaporative power of boilers, principally the long boilers of Stephenson's engines and the ordinary type of Gooch's

Speeds.—Omitting Pambour's Liverpool and Manchester experiments, the earliest speed records were those made by Whishaw in 1839, the analysis of which contains some items of interest. The highest speeds mentioned are 68.2 miles per hour down the Madeley Bank of 1 in 177 into Crewe on the Grand Junction Railway. Analysis of these particular speeds shows that they cannot be accepted. There were four different trains with which 68.18 miles per hour were recorded, but no train on the same section showed a maximum speed between this and 56¾ miles per hour. The explanation can be supplied from Whishaw's own notes. On the Madeley Bank there were distance posts every 100 yards, and he attempted to record the times passing each post. Experience of reliable

TABLE III.

Maker.	Type of engine.	Driving wheels.	Cylinders.	Heating surface		Continued working.	Miles run.	Coke per mile.	Cost of repairs.	Repairs, pence per 100 miles.
				Tubes sq. ft.	Fire-box sq. ft.					
Sharp Brothers	2 2-2 inside cylinders outside frames	5ft. 6in.	15in. x 18in.	476	60	Feb., 1844 to Apl., 1845	40,135	31.54	£ s. d. 137 8 8	82.18
Bury	2 2-0 inside cylinders inside bar frames	5ft. 6in.	14in. x 18in.	595	59	Aug., 1844 to Apl., 1845	14,626	35.07	109 7 10	179.5
Stephenson	2-2-2 long boiler outside cylinders	5ft. 6in.	15in. x 22in.	893	55	Oct., 1844 to Apl., 1845	18,447	29.55	67 14 1	88.08

train timing shows how difficult it is even to obtain accurate $\frac{1}{4}$ -mile-post readings, and an error of half a second in Whishaw's 100-yard timings would reduce his 68.2 to $58\frac{1}{2}$ miles per hour. Moreover, the 68.18 miles per hour of the four trains is equivalent to the 100-yard interval in three seconds exactly, a suspiciously round number. On no other railway does Whishaw record any speed exceeding 50 miles per hour, and even this was exceptional. The probability is that 55 to 58 miles per hour was the maximum, very rarely attained even down the Madeley Bank. The writer has dealt with this point in the interests of accuracy, since even Colburn² accepted Whishaw's 68.2 miles per hour without due consideration.

Whishaw's other records, taken at half-mile and mile posts, are more reliable. He records a maximum of 50 miles per hour on the Liverpool and Manchester Railway with a 2-2-2 engine, on a run of $14\frac{1}{2}$ miles with one stop. The running average, excluding the stop, was $30\frac{1}{2}$ miles per hour, with a load of $22\frac{1}{2}$ tons. There is also one record of 50 miles per hour on the London and South-Western with 46 tons down 1 in 388 near Woking.

The most interesting records are those of the London and Birmingham Railway, since they show performances of Bury's four-wheeled locomotives. The four-coupled goods engines gave higher speeds on the passenger trains than the "single" engines, though this is not apparent from Whishaw's figures, since he gave no particulars of the engines beyond recording their numbers. From a large number of timings the following have been selected:—

Engine.	Distance travelled miles.	Load tons.	Max. speed.	Average speed.	
Passenger.					
5ft. 6in., 12in. x 18in.	$15\frac{3}{4}$	$57\frac{1}{2}$	37.5	23.8	
Ditto	$112\frac{1}{2}$	$27\frac{3}{4}$	42.8	23.7	
Ditto	60	62	46.1	26.4	
Goods.					Two engines
5ft., 13in. x 18in.	35	27	40.5	27.8	
Ditto.	42	$37\frac{1}{2}$	50.0	26.8	

The average speed is that of the train when in

² "Locomotive Engineering," page 55.

motion, and owing to stops is lower than would have been the case with through runs.

On the G.W.R. broad gauge the timings were made between Paddington and Maidenhead only. The best result was given by Stephenson's "North Star," which, with 30 tons, averaged 31.8 miles per hour, the maximum speed being 46.8 miles per hour. Maximum speeds of 50 miles per hour were attained by the 8ft. engines "Vulcan" and "Bacchus," but with loads of 14 to $17\frac{3}{4}$ tons only.

From 1839 until the end of 1845 very little is known on this subject. The run from York to Darlington in 1845 at an average speed of 51 miles per hour by Hawthorn's 6ft. 6in. single engine has already been mentioned. The fastest speeds on the standard gauge are stated to have been attained on the North Midland and the Eastern Counties railways (Bishop's Stortford line), but no exact particulars are obtainable. Both railways employed express engines with 6ft. driving wheels.

But there is no doubt that the Great Western carried off the speed honours. During the trials the "Ixion," with 7ft. wheels and $15\frac{3}{4}$ in. by 18in. cylinders, ran from London to Didcot at an average speed of 47.5 miles per hour, with $81\frac{1}{2}$ tons, and at 52.4 miles per hour with 61 tons. On the return journeys, the gradients being slightly downhill, the running averages were 50 miles per hour with $81\frac{1}{2}$ tons, and 54.6 miles per hour with 71 tons. Maximum speeds of 60 to 62 miles per hour were attained.

The standard gauge trials between York and Darlington were carried out with one of Stephenson's long boiler engines with rear driving wheels 6ft. 6in. diameter and outside cylinders 15in. by 24in. The average speeds were about 47 miles per hour with 50 tons and $43\frac{1}{4}$ miles per hour with 80 tons. The highest speeds were 58 and $50\frac{3}{4}$ miles per hour respectively. The same engine, about three weeks later, attained 60 miles per hour with a 40-ton train on the same line.

The highest booked time-table speeds in 1845 were:—

G.W.R., Swindon to Bath	$29\frac{3}{4}$ miles at 48.2 m.p.h.
" Paddington to Didcot	53 " 47.5 "
" Taunton to Bristol... ..	$44\frac{3}{4}$ " 47.1 "
E.C.R., London to Broxbourne	19 " 43.8 "
L. and B.R., Wolverton to Coventry (including one stop)	$41\frac{1}{2}$ " 43.7 "

Chapter VII — 1846-49

THE effect of the Gauge Commission on locomotive practice was extremely marked, in that engineers were stimulated to construct engines of much greater power, with the result that the years 1846-9 were remarkable not only for some very large locomotives, but also for bold and varied designs. Included in this period are the outside cylinder "Crampton" type engines, which,

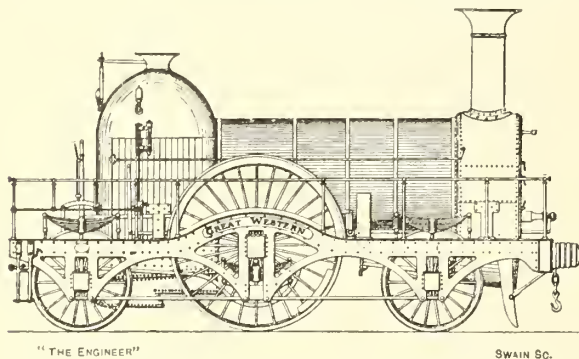

FIG. 67.—GOOCH'S BROAD GAUGE "GREAT WESTERN," BUILT AT SWINDON, 1846

though they did not produce any lasting effect on British practice, nevertheless had great influence on Continental locomotive design. Before dealing with them, the Great Western broad gauge developments will be considered.

Gooch's Great Western Railway Broad Gauge Engines, 1846-9.—In April, 1846, the first of the

equally divided. Heating surface of 278 2in. tubes, 1582 square feet; of fire-box, 151 square feet; total, 1733 square feet. Grate area, 22.6 square feet. Pressure, 100 lb. per square inch. In June, 1846, the "Great Western" was stated to have run with 100 tons from London to Swindon, 77½ miles, in 78 minutes, and the same month worked through to Exeter and back, the 194 miles each way being covered in 208 and 211 minutes' running time respectively. The leading axle subsequently broke, after which the engine was altered and provided with two pairs of leading wheels, as in the later engines.

The following class was less ambitious, and consisted of six engines, built in 1846-7, with 16in. by 24in. cylinders and 7ft. driving wheels—one engine with 7ft. 6in. wheels. They were characterised by inside frames only, which were of the sandwich type. The total heating surface was 1082 square feet, and the weight in working order 26 tons 2½ cwt.

The "Great Western" having proved very successful, twenty-two additional engines of an improved type were built at Swindon in 1847-51—Fig. 68. They had the ordinary form of raised fire-box casing, and ran on eight wheels, the drivers being 8ft., and the carrying wheels 4ft. 6in. diameter. As originally made the driving wheels had no flanges. The total wheel base was 18ft. 6in. The cylinders, 18in. by 24in., placed at 4ft. 2½in. centres, were completely closed in and jacketed by the lower part of the smoke-box.

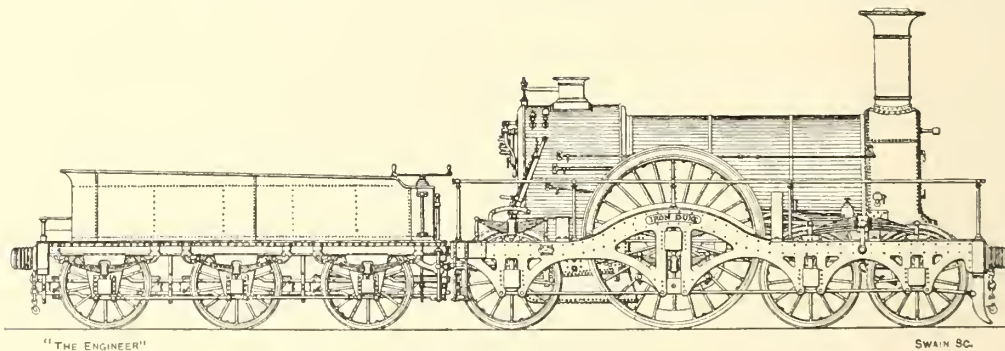
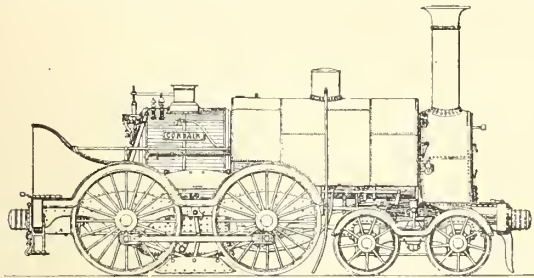

FIG. 68.—GREAT WESTERN RAILWAY BROAD GAUGE ENGINE "IRON DUKE," 1847

famous 8ft. single engines was built at Swindon. This was the "Great Western"—Fig. 67—built as a trial engine, which differed from the succeeding "Iron Duke" class in that it ran on six wheels only, and had a fire-box casing of the "Gothic" form. The engine was specially built in view of the impending renewal of the gauge controversy before Parliament. The cylinders were 18in. by 24in. Driving wheels, 8ft., carrying wheels, 4ft. 6in. diameter. Wheel base, 16ft.,

In addition to the outside sandwich frames, there were inside plate frames between the back of the cylinders and the front of the fire-box casing, as well as a fifth frame or "centre stay" of the same length along the centre line of the engine. Each of the five frames had a bearing for the driving axle, but the carrying axles had bearings in the outside frames only. The slide valves were partially balanced by means of pistons in the common steam chest. The pistons worked inside

a small cylinder open at the ends, and were coupled by links to the backs of the valves. The principal objections to this method were the rattling noise, the danger of the link pins coming out and getting



"THE ENGINEER" SWAIN SC.
FIG. 69—GOOCH'S SADDLE TANK ENGINE, G.W.R., 1849

into the cylinders, and the wear of the balance piston rings, which caused leakage and consequent loss of the balancing effect. Subsequently ordinary unbalanced slide valves were substituted. The boiler barrel was 4ft. 9 $\frac{3}{4}$ in. diameter outside the largest ring, pitched with centre 7ft. 2in. above rails. There were 303 2in. tubes, which in the first six engines—"Iron Duke" class—provided 1647.4 square feet of heating surface, to which the fire-box, with transverse partition added 142.8 square feet; total, 1790.2 square feet. Grate area 21.6 square feet. Pressure originally 100 lb., afterwards increased to 120 lb. The later sixteen engines—"Courier" class—had shorter tubes and a longer fire-box. The heating surface of the latter was 156.5 square feet, and the total 1767 square feet. Grate area 25 $\frac{1}{2}$ square feet. The weights in working order varied from 35 $\frac{1}{2}$ tons with 12 tons 6 cwt. on the driving wheels in the earlier engines to 38 $\frac{1}{4}$ tons with 14 tons on the drivers in the later engines. All were fitted with Gooch's stationary link motion.

The boilers were domeless, and steam was taken from a perforated pipe—Hawthorn's 1839 patent—which terminated at a regulator box in the smoke-box. The regulator was of the slide valve type with pull out handle. The wheels, including the 8ft. drivers, were of wrought iron forged solid with the bosses. The revolving masses were balanced by weights in the rims of the driving wheels. A single inverted spring on each side carried the weight on the two leading axles.

Seven more engines of this class were built in 1854-5 by Rothwell and Co., making a total, including the "Great Western," of thirty. Although most of the original engines were broken up between 1870 and 1880, they were replaced by new engines almost exactly similar but with 140 lb. pressure. In the later engines cabs were also provided, and the total weight was increased to about 41 $\frac{1}{2}$ tons, of which 16 tons rested on the driving wheels.

Twenty-three were at work on the fastest main line trains in May, 1892, when the broad gauge

ceased to exist. When they were new they were ahead of the times, but in their later years, as train loads increased, the lack of adhesive weight told badly against them. Further particulars will be found in *The Engineer*, June 16th, 1882, page 429.

The broad gauge 0-6-0 goods engines of 1847, though large machines, had a tractive force considerably lower than that of some of their standard gauge contemporaries, but they excelled the latter in boiler power. Their principal claim to interest lies in the position of the trailing axle behind the fire-box, coupled with the use of inside—sandwich—frames. The wheels were 5ft. diameter, cylinders 16in. by 24in., and heating surface 1363 square feet. Weight in working order, 27 $\frac{3}{4}$ tons.

The 4-4-0 saddle tank engines—Fig. 69—built in 1849, were amongst the most interesting of Gooch's designs. The type of bogie, which with minor modifications, was in use until May, 1892, swivelled on a ball and socket joint, the socket being connected diagonally with the horn plates by four strong forgings, 5in. deep by 1 $\frac{1}{2}$ in. thick—Fig. 70. The pivot or ball was riveted into a double gusset, which in turn was riveted to the bottom of the boiler and the steam chest. A single inverted spring transmitted the load to the two axle-boxes on each side. As equalising levers were provided between the coupled wheels, the spring-

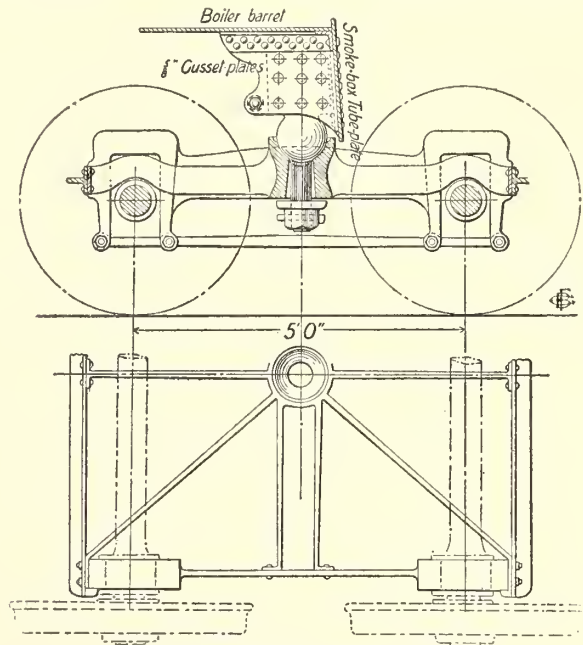

FIG. 70—GOOCH'S BOGIE, 1849

borne weight was carried on three points, and the engines were the first in this country, except Carmichael's Dundee and Newtyle and the Norris engines—Figs. 22 and 42A *ante*—in which this method of spring suspension was used. The main inside sandwich frames were rigidly fastened to

the boiler by strong brackets, and extended from these, which were situated at the front of the driving wheels, to the back buffer beam. The force between the cylinders and driving axle was, therefore, transmitted through the boiler, except for the intervention of a single centre stay from the back of the cylinders to the front of the fire-box casing. The front buffer beam was connected to the cylinder sides by plates. The whole arrangement was radically defective, and the first twenty-one engines of the type were scrapped as soon as their original boilers were worn out. Similar engines on the South Devon railways from about 1866 had plate frames from front to back.

The cylinders were 17in. by 24in., coupled wheels of the first two engines built at Swindon in 1849, 6ft., and of thirteen built by R. and W. Hawthorn in 1854, 5ft. 9in. The bogie wheel base was 5ft. only. The bogie had a swivelling movement without lateral play, and there was no arrangement to prevent cornering except the top of the front axle guard, which ultimately came into contact with the smoke-box casing surrounding the cylinders. In all Gooch's bogie engines the bogies were set well back to reduce the total wheel base, which in the above engines was 18ft. 2in. The driving tires were flangeless. These engines had sledge brakes bearing on the rails between the coupled wheels. These were a constant source of trouble, not only damaging the rails, but frequently getting on the wrong side of crossings. When in action, they lifted the back end of the engine on the springs, in some cases reducing the weight on the coupled wheels to a dangerous extent. The iron tires had steel faces.

Outside Cylinder Crampton Locomotives.—The Crampton locomotive was another attempt to obtain a large heating surface combined with a low centre of gravity. The patentee, Thomas Russell Crampton, held the opinion that a steady engine would result if the centre of gravity was situated as nearly as possible on the same horizontal line as the draw-bar. This was true so far as the vertical "pitching" movement was concerned, especially as he made a point of avoiding overhanging masses at each end, and of distributing the weight so that the greater part was carried by the leading and the trailing (driving) wheels, with comparatively little on the middle carrying wheels. As the driving wheels were placed at the rear, behind the fire-box, the cylinders were brought back to a position near the middle of the engine, between the two front carrying axles, and lateral swaying was thereby reduced.

Moreover, Crampton was probably the first locomotive engineer to point out that the hind axle of an engine passing round a curve does not move towards, but away from, the outer rail. This fact, which has an important bearing upon the wear of tires, has long been recognised by Continental locomotive engineers, but appears to have been accepted in this country only of recent years.

But for this, the flange wear of the large rear driving wheels of Crampton's engines would have been excessive.

Crampton's first patent of February, 1842 (not 1843, as given by D. K. Clark), combined two claims. In the first the boiler was slung under the driving axle of a six-wheeled engine, but no engine of this type was built until Francis Trevithick produced the "Cornwall" at Crewe in 1847. In the second claim a four-wheeled engine was proposed, in which the driving axle was placed behind the fire-box. But actually when the first engines were built in 1846 it was found necessary to have six wheels, and therefore two pairs of front carrying wheels were used.

The date of the patent shows that Crampton was not attempting to improve upon Stephenson's long boiler design by making a steadier engine, since only two or three long boiler engines of the inside cylinder type had then been at work a few weeks. It is open to question whether the position of the driving wheels behind the fire-box was really patentable, since Stephenson and Tayleur had built such engines for America in 1833—see Fig. 20 *ante*. Crampton stated that he did not know this until many years later, and it does not appear that R. Stephenson or others ever questioned the validity of the patent.

Most of Crampton's engines had large 7ft. driving wheels, and in two they were as large as 8ft. for the reason that tire wear was thereby reduced. The length of turntables did not trouble Crampton, as it had affected Stephenson when designing the long boiler engines. Crampton's earliest engines had a total base of 13ft. to 14ft., and in the eight-wheeled "Liverpool" it was 18ft. 6in. (Fig. 72).

Features of the design included a driving axle which was situated above the footplate just below the fire door and enclosed within a casing. The driving horns were inverted, and placed above instead of below the main frames. The driving springs had very long spring pillars, which raised them level with the tops of the driving wheels, and the front hanger was attached to the fire-box shell. Alternatively, a single transverse spring was used, which was carried across the footplate immediately in front of the driver. Many of the boilers were elliptical with flattened sides, stayed across. The whole of the motion and valve gear were outside.

The first two engines were built by Tulk and Ley, of Whitehaven, in 1846, for the Namur and Liège Railway—then a British-owned company. They had 7ft. solid wrought iron wheels and 16in. by 20in. cylinders. The total heating surface on the fire side was 989 square feet, and the grate area 14½ square feet. In these and most of the succeeding engines the fire-box was extremely short at the top, being only about 2ft. long for the depth of the tube plate; below the latter it was splayed out both at the front and back to a length of 5ft. to 6ft. An exactly similar

engine was built in 1848 by Tulk and Ley for the Dundee and Perth Railway. This type is shown by Fig. 71.¹

One of the Namur engines was tested before export on the Grand Junction Railway, with the result that the L. and N.W.R. decided to try "Cramptons." The first of them was the "Courier," which was built at the Crewe works in November, 1847, under Allan's supervision,² from

was totally different in detail from all other "Cramptons." The driving wheels were 7ft. and the cylinders 16in. by 20in.; pressure, 90 lb. This engine is shown by Fig. 73.

For the southern division of the L. and N.W.R. a larger six-wheeled engine, with 8ft. driving wheels and 18in. by 20in. cylinders, was built by Tulk and Ley in 1847. The oval boiler had a diameter of 4ft. 8in. vertically and 3ft. 10in.

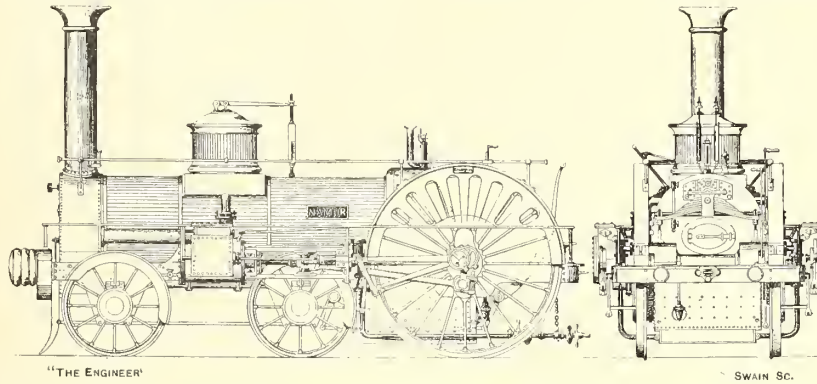

FIG. 71—CRAMPTON ENGINE "NAMUR," BY TULK & LEY, NAMUR AND LIEGE RAILWAY, 1846

general drawings supplied by Crampton, though some of the details show the Crewe practice of that period, including an outside frame stay between the cylinders and the trailing buffer plate. The fire-box was raised 1ft. 9in. above the barrel to provide room for a second pipe, from which steam could be taken, in addition to the pipe in the dome. This was necessary since the oval boiler was packed with 196 $\frac{1}{4}$ in. tubes, which left too

horizontally, and was stayed transversely throughout its length. The total heating surface was 1529 square feet. Grate area, 16 square feet; pressure, 100 lb. The tires were of Bowling iron, purchased in 12ft. and 25ft. 6in. lengths and afterwards welded up. The weight in working order was a good example of the distribution at which Crampton aimed. Of the total of 25 tons 12 cwt., when loaded, 11 tons 14 cwt. rested on

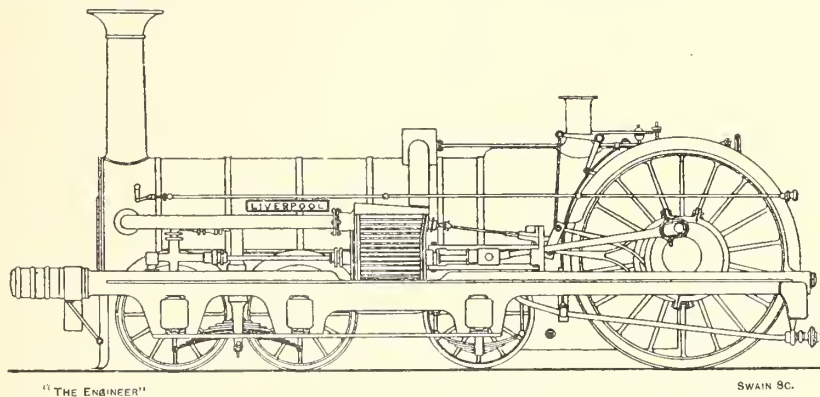

FIG. 72—CRAMPTON ENGINE "LIVERPOOL," L. & N.W. RAILWAY, 1848

small a steam space. The boiler centre was only 4ft. 7in. above rail level. The steam chest was above the cylinders, and the valves were worked by rocking shafts and Gooch's link motion, the only instance of the use of this gear in a Crewe-built engine. In most respects the "Courier"

the rear drivers, and 8 tons 3 cwt. on the front carrying wheels, leaving only 5 tons 15 cwt. on the middle wheels. Complete drawings of this engine, the "London," were published in *The Engineer*, November 28th, 1890.

All the above engines, as well as a number on the South-Eastern Railway,³ had inside frames

¹ Fig. 71 has been reproduced from "Die Crampton Lokomotive," by F. Gaiser, Neustadt a.d. Haard, 1909, the only book which gives a full account of Crampton's engines.

² Letter from Alex. Allan quoted in *THE ENGINEER*, May 25th, 1883, page 405.

³ Illustrations and particulars of several of the South-Eastern "Cramptons" may be found in an article by Mr. A. Rosling Bennett in *THE ENGINEER*, July 1st, 1910.

and bearings only, for all axles. In this respect they differed from Crampton's later designs of 1848, in which there were two frame plates on each side, between which the cylinders were fastened. The carrying wheels had bearings in the outside frames only, but the driving bearings were inside. In these engines the boiler was independent of the

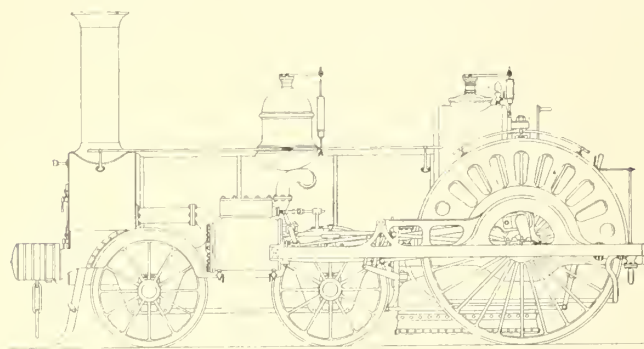

FIG. 73—CRAMPTON ENGINE "COURIER," L. & N.W. RLY., 1847

framing, upon which it rested by means of brackets, a great improvement upon the usual method of rigid connection. The frames were strongly braced by transverse plates. Another excellent feature was long bearings, those of the driving axles being 12in., and of the carrying axles 10in. long. The wheels were of wrought iron throughout.

The boilers were domeless, steam being taken from an internal pipe with a slit along the top and a short T pipe branching upwards near the middle. This T pipe entered a small square box which contained the double slide valve regulator, moved longitudinally by an external rod. The steam pipes to the cylinders branched out on each side of the box and were carried externally down to the cylinders which lay immediately below. This was the well-known Crampton regulator, used extensively for many years in France and Germany, but only on a few Crampton engines in this country.

Of the above "mixed framed" engines E. B. Wilson and Co. built five in 1848 for the Eastern Counties Railway, with 16in. by 20in. cylinders and 7ft. driving wheels. The leading wheels were 4ft. 6in., but the middle wheels were 3ft. 6in. diameter in order to clear the cylinders. The total wheel base was 15ft. 3in. These were the fore-runners of the celebrated French "Cramptons" on the Nord and other railways, which were of very similar design, though of somewhat different dimensions, and had flush fire-box casings. Boilers of this latter design have always been known in France as "chaudières Crampton."

The large eight-wheeled engine "Liverpool"—Fig. 72—for the L. and N.W.R. (Southern Division) was built by Bury, Curtis and Kennedy in 1848, and shown in the 1851 Exhibition. It

also had mixed framing, both inside and outside plates extending throughout from front to back buffer beams. The two leading carrying axles had one inverted spring on each side, as in Gooch's 8ft. engines, but all the carrying axle springs were underhung. Unlike the Eastern Counties Railway "Cramptons" which had Gooch's gear, the "Liverpool" had Stephenson's link motion. In the early "Cramptons" the excentrics were of small size and fixed on return cranks as in Fig. 71, but in the "Liverpool" huge excentrics, the sheaves of which were about 2ft. 9in. in diameter, were fixed to the driving wheel bosses, with the object of avoiding overhung return cranks. This form of excentric was patented by Crampton in June, 1847, and was first used on the "Cornwall" and "Velocipede," built at Crewe, but was soon abandoned owing to the enormous friction and consequent heating. The fire-box of the "Liverpool" had a longitudinal midfeather with two grates and two firehole doors.

The driving wheels were 8ft. diameter and the cylinders 18in. by 24in. The total (rigid) wheel base was 18ft. 6in. The boiler, the centre of which was only 5ft. 3in. above rail level, was oval and contained 292 $2\frac{3}{16}$ in. tubes, the heating surface of which was 2136 square feet; total heating surface, 2290 square feet; grate area, 21.5 square feet; pressure, 120 lb.; weight in working order, about 35 tons.

The "Liverpool" worked heavy trains between London and Wolverton, but can hardly be considered otherwise than as a daring freak. It damaged the road badly, perhaps less on account of its weight than of its long rigid wheel base.

A unique design of Crampton engine is shown in Fig. 74. Two engines of the kind were built in 1848 by Kitson, Thompson and Hewitson for the Midland Railway. The speciality lay in the deep double frame, which had outside bearings for the leading and trailing (driving) axles, but the middle axle had inside bearings only. The connecting-rods of the outside cylinders drove a crank pin fixed outside in the driving wheels, this pin having a crank arm and outer overhanging journal for the axle-box in the outside frames. The main and larger bearings for the driving axle were in the inside frames. The cylinders were 16in. by 22in. and the driving wheels had a diameter of 7ft. Total heating surface, 1062 square feet, but the grate, like that of all "Crampton" engines, was small—13.9 square feet.⁴

In all, there were about twenty-five outside cylinder "Cramptons" on British railways, of which five on the South-Eastern had been reconstructed from long boiler engines of the Stephenson type. These and three new engines by Tulk and Ley, 1849, lasted until about 1865,

⁴ Further particulars and drawings of the Midland Railway "Crampton" engine were given by Mr. E. A. Forward in the *LOCOMOTIVE*, August 15th, 1922.

one or two until 1874-5, but on all other railways they were withdrawn from service after eight to ten years' work only.

In France and Germany the "Cramptons" were well liked and nearly 300 were constructed up to 1864. Moreover, they remained in service much longer, and a number were still at work on the Eastern Railway of France until well into the present century. One of the reasons for this difference of opinion between British and Continental engineers on the merits of Crampton's system may have been due to the conditions of the respective road beds and permanent way of that period, though there is no direct evidence that the "Cramptons" in this country or abroad damaged the road, except in the case of the "Liverpool," which was an exceptional engine with an extremely

on the slide bars was in the same transverse plane as the centre of gravity of the engine. The mid-position of the cylinders, and the longer wheel base considerably reduced the swaying.

The defect of Crampton's system was the small proportion of adhesive to total weight, owing to the distance of the driving axle from the centre of gravity, and this defect would have been still more serious but for the heavy non-spring-borne weight of the large driving wheels. On many of the Continental engines a weight had to be added at the footplate end. On the other hand, the adhesion of the rear driving wheels on moderate curves is greater, since the trailing axle tended to run radially.

The "Cramptons" were fast runners. D. K. Clark mentions that the L.N.W.R. 8ft. engine

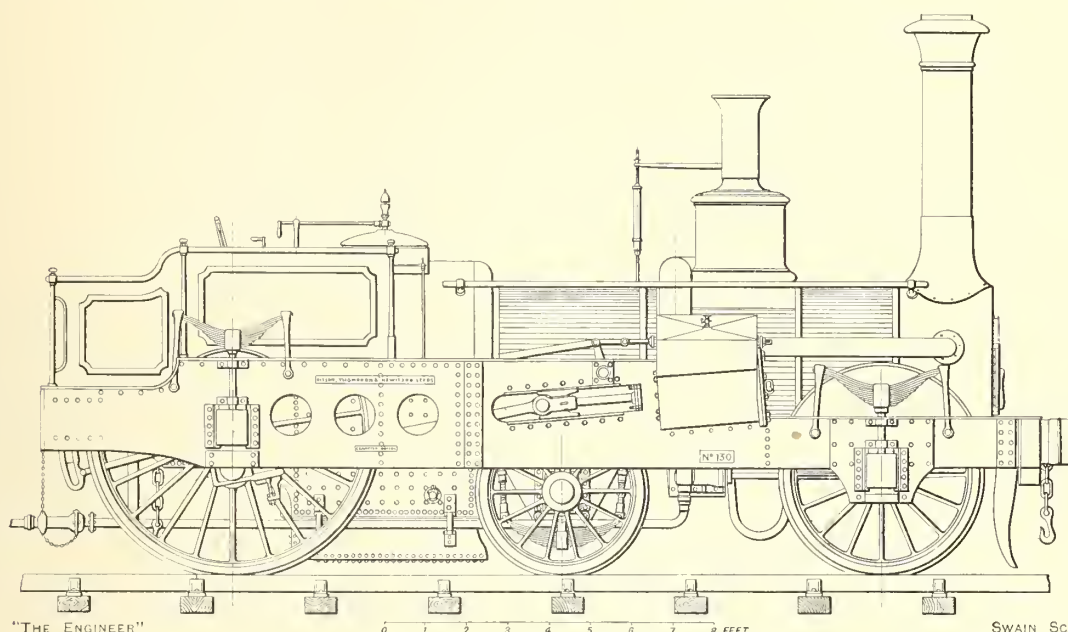

FIG. 74—CRAMPTON ENGINE BY KITSON, THOMPSON & HEWITSON, MIDLAND RAILWAY, 1848

long rigid wheel base. Continental experience showed that they were steady engines at high speeds, and the chief complaint against them was the vibration on the footplate owing to the position of the driving axle. It was only at a later date, as train loads increased, that lack of adhesion told against them. But there was an objection abroad to the 2-2-2 engine of that day with driving axle in the middle, since the weight on this axle in many cases was 50 per cent. or more of the total, and the leading axle was too lightly loaded. On an uneven road bed there resulted a vertical "pitching" movement about the driving axle, and the already lightly loaded leading axle was periodically relieved of part of its weight. In the "Cramptons" the leading axle was comparatively heavily, and the middle axle lightly loaded, with the result that very little "pitching" took place, more especially since the upward thrust

"London" took a train of eleven coaches—55 tons—at 53.4 miles per hour in one run of 30 miles. In the trials on the P.L.M. Rly. after the Paris Exhibition of 1889 the highest speed of all the engines tested, 89.5 miles per hour, was attained by a single driver "Crampton" with a load of 157½ tons. This engine had the reciprocating masses balanced, which was not the case in the early engines in this country.

Other Express Engines of Special Types.—Three of these merit special mention. One was the L. and N.W.R. "Cornwall," built at Crewe in November, 1847, to Mr. Francis Trevithick's design. To obtain a low centre of gravity the boiler was made of an extremely complicated shape and placed below the driving axle. The arrangement is shown in section in Colburn's "Locomotive Engineering," page 71. The driving wheels were 8ft. 6in. diameter. The

driving axle passed through a channel recessed in the top of the boiler, and the trailing axle through a transverse tube through the fire-box. The underhung boiler formed part of Crampton's patent of 1842—Fig. 75.

A few years ago original drawings of the

original engine, except part of the outside frames and the wheel centres, can have remained. The old 17½ in. by 24 in. cylinders had inclined steam chests above the level of the boiler, and the valve gear was driven by Crampton's type of large outside eccentrics, similar to those of the "Liver-

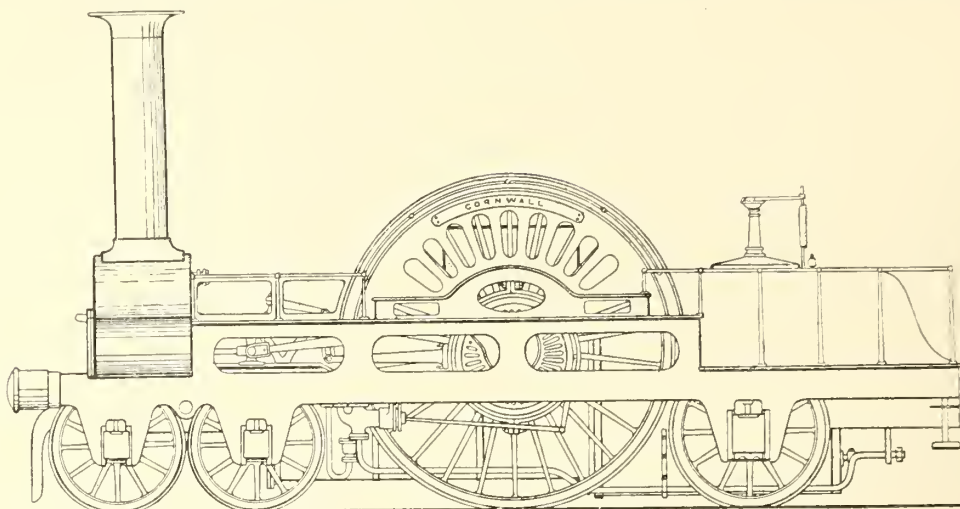

FIG. 75—F. TREVITHICK'S "CORNWALL," L. & N.W. RAILWAY, AS BUILT 1847

"Cornwall" were published⁵ showing the engine on six wheels only, with a wheel base of 12 ft. 11 in., and both carrying wheels 4 ft. diameter. It is possible that it was actually built in this form, and was shortly afterwards converted to the eight-wheeled type, as illustrated in Colburn, with two pairs of leading wheels 3 ft. 6 in. diameter, and a total wheel base of 16 ft. 6 in. The drawing of the six-wheeled engine shows considerable overhang at the leading end, and the weight of the leading axle, just as in the parallel case of Gooch's first 8 ft. engine, probably

pool." The new cylinders, 17¼ in. by 24 in., had vertical steam chests of the Allan type inside the frames, and the valve gear was also entirely inside. In this reconstructed form the "Cornwall" is illustrated in Fig. 75A, except that the cab is a later addition. It is still in service on the Mechanical Engineer's saloon coach, after having worked the fast expresses between Manchester and Liverpool until 1902, when it was withdrawn from regular train service.

Another type of L. and N.W.R. express engine by Stephenson, 1848-9, was directly derived from

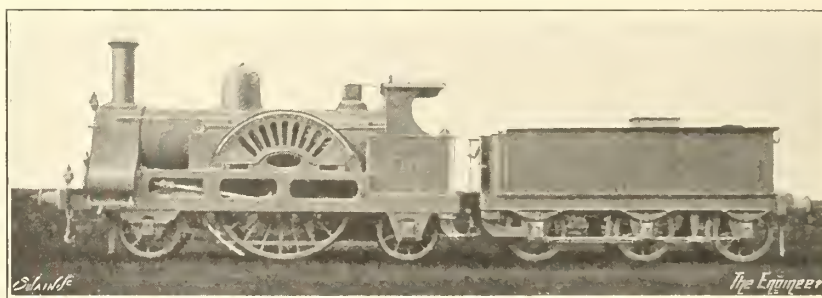

FIG. 75A—THE "CORNWALL," L. & N.W. RAILWAY, AS REBUILT 1858

necessitated the alteration. At the 1851 Exhibition the "Cornwall" had eight wheels.

The "Cornwall" was completely reconstructed by Ramsbottom in 1858 as a six-wheeled engine with ordinary boiler above the driving axle, and a wheel base of 14 ft. 10 in. Very little of the

the long boiler engine with rear driving wheels by the addition of a small pair of carrying wheels with outside bearings behind the fire-box, whereby a steadier eight-wheeled engine was obtained, shown by Fig. 75B. There were two of these with 7 ft. driving wheels and cylinders 18 in. by 21 in. and 16 in. by 24 in. respectively.

⁵ THE RAILWAY GAZETTE, July 5th, 1918.

The wheel base was 17ft. 6in., and the total heating surface $1366\frac{1}{2}$ square feet. Of this the fire-box, with midfeather, provided $91\frac{1}{2}$ square feet. The weight in working order was 30 tons, of which $12\frac{1}{2}$ tons were available for adhesion. The engine with 18in. cylinders was subsequently altered to 16in. Outside bearings *at the trailing end only* of an inside framed engine were not new. The arrangement first appeared in Rennie's London and Croydon engine of 1838 and later in 1846 in some 2-2-2 engines by Stothert and Slaughter for the Eastern Counties Railway. It is now frequently used in modern practice.

Three-cylinder Engine.—A design of loco-

throw for the inside cylinder, which was $16\frac{3}{8}$ in. diameter by 18in. stroke. The two outside cylinders, each $10\frac{1}{2}$ in. by 22in., drove the same axle by means of crank pins in the wheels. Both outside cranks were on the same centre, *i.e.*, at 0 deg. with each other, and were 90 deg. in advance of the inside crank. The driving wheels were 6ft. 6in. diameter. Since both outside pistons always moved in the same direction, and the inside piston was on the centre line of the engine, it resulted that there was no "swaying" or nosing couple, though the longitudinal fore and aft surging force would be greater. According to the patent specification the arrangement

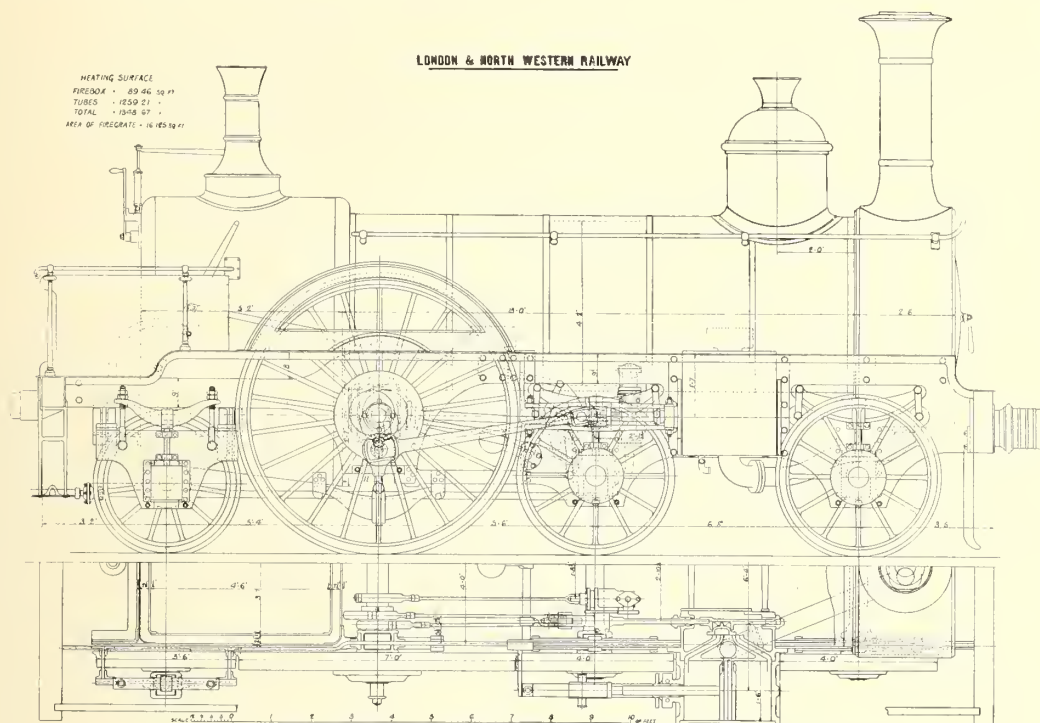

FIG. 75B—STEPHENSON'S EXPRESS LOCOMOTIVE, L. & N.W. RLY., 1848

From "A Century of Locomotive Building," by permission of Robert Stephenson & Co., Ltd.

tive with three cylinders was patented by Isaac Dodds in 1839, in which two outside cylinders placed at the side of the fire-box drove the leading wheels, and the inside cylinder under the smoke-box drove the middle wheels. There was a small pair of carrying wheels behind the fire-box.⁶ There is no evidence that such an engine was ever built.

In 1846 R. Stephenson and Co. built a three-cylinder engine of the "rear driver" long boiler type—Stephenson and Howe's patent. The three horizontal cylinders were in the same transverse plane, and placed between the two front carrying axles. The rear driving axle being in front of the fire-box allowed of a crank axle with a central

was primarily intended to prevent alternate lifting of the engine due to the difference between the upward pressures on the slide bars on each side of an outside cylinder engine with cranks at 90 deg.

The engine was tried on the L. and N.W.R., and on a special train in April, 1847, ran with five carriages from Wolverton to Coventry, 41 miles, in 42 minutes.⁷

In 1853 it was reconstructed by Messrs. Stephenson for the York, Newcastle and Berwick Railway as a 2-2-2 engine with middle driving wheels, and the three cylinders in line with the smoke-box. The outside cylinders were fixed between the inside and outside frames. The

⁶ The design is illustrated in "A Story of Railway Pioneers" by Major Snell, M.C.

⁷ THE TIMES, April 29th, 1847.

driving axle had bearings in the inside frames only, and the carrying axles in the outside frames. The left-hand eccentrics actuated the valves of the inside cylinder, and the right-hand eccentrics the valves of both outside cylinders through the medium of a cross shaft. The engine in this form worked for many years on the North-Eastern Railway.⁸

Bar-framed Engines—Bury Type.—At the end of 1845 Bury, Curtis and Kennedy were compelled by force of circumstances to adopt the six-wheeled engine, but retained the bar frames. Most of

development of John Gray's mixed framed engine, with inside bearings only for the driving axle and outside bearings for the leading and trailing axles. Gray himself designed twelve express engines for the London and Brighton Railway, which were generally similar to his original Hull and Selby engines of 1840, but of larger dimensions. The cylinders were 15in. by 24in., and the driving wheels 6ft. diameter. They carried a pressure of 100 lb., and, in accordance with Gray's sound ideas, the boiler centre was pitched 6ft. 3½in. above rail level. These engines,

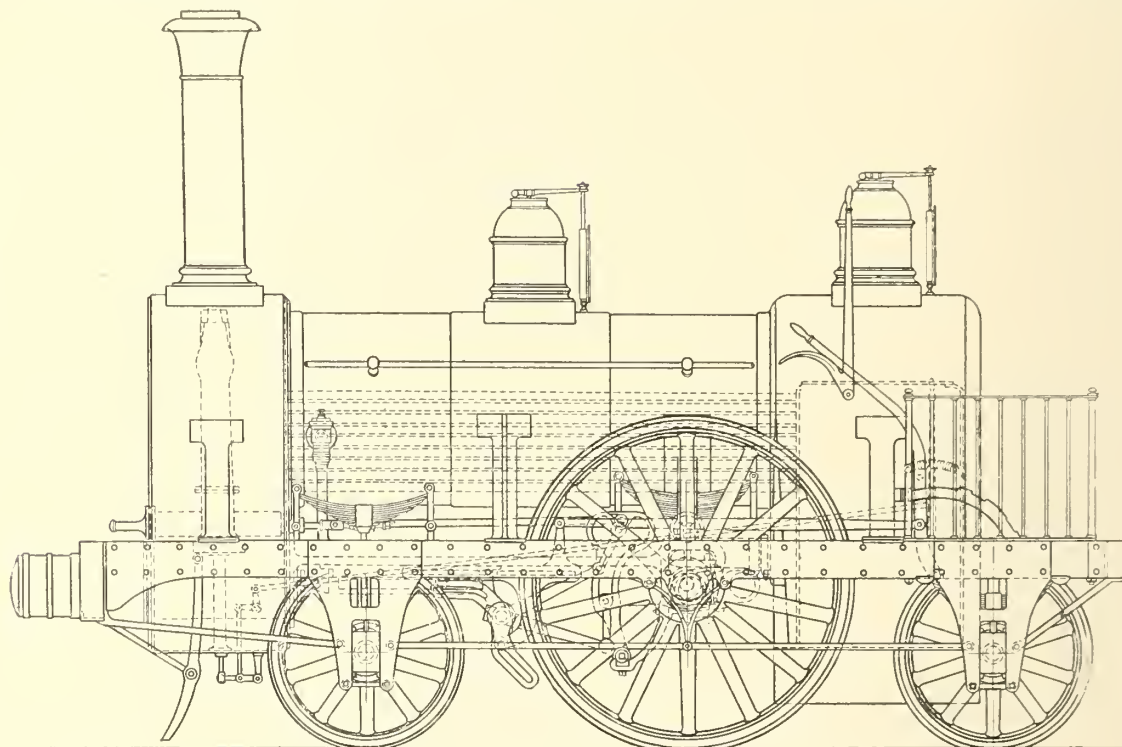

"THE ENGINEER"

SWAIN SC.

FIG. 76—GRAY'S EXPRESS ENGINE, BUILT BY SHEPHERD & TODD, HULL & SELBY RLY., 1840

their six-wheeled engines were of the 2-2-2 and 0-4-2 types. The driving and trailing horns were welded to the horizontal bars, but the leading horns were bolted on. More detailed particulars of Bury's later practice were given in the writer's article in *The Engineer* of February 2nd, 1923, to which reference may be made. The firm's last bar-framed engine was put to work early in 1850 on the Shrewsbury and Birmingham Railway, but a number of four-wheeled bar-framed goods engines of Bury's type, with tall haystack fire-boxes, were built by W. Fairbairn and Sons until 1861, after which bar frames completely disappeared from British practice for home railways.

"Standard" Passenger Engines, Inside Cylinders.—From 1846 onwards there was a great

which were fitted with Gray's "horseleg" expansion gear, were built in 1846-8 by Timothy Hackworth at Shildon, and in appearance were very similar to the Hull and Selby engines built by Shepherd and Todd in 1840 and illustrated in Fig. 76.

Gray's design was the immediate origin of the celebrated "Jenny Lind" engines—Fig. 77—designed by David Joy and built by E. B. Wilson and Co., Leeds, from 1847 onwards. An account of the steps which led to the design was given by D. Joy in *The Engineer*, May 22nd, 1896, page 527.

The cylinders were 15in. by 20in., driving wheels 6ft., carrying wheels 4ft., and wheel base 7ft. + 6ft. 6in.; the tube heating surface was 720 square feet, fire-box heating surface 80 square feet, total 800 square feet. The boiler pressure was 120 lb., or 20 lb. higher than in Gray's engine, and to this the great success of the

⁸ For a full account with illustrations of the three-cylinder locomotive in both of the above forms see Warren, pages 392-4 and 402. For drawings of the 2-2-2 type see D. K. Clark, "Railway Machinery," plate 16.

"Jennys" may be largely attributed. The use of this higher pressure was due to James Fenton. In one respect Messrs. Wilson apparently did not venture to follow Gray's example, for the boiler centre was only 5ft. 9in. above rail level, or 6½in. less than in Gray's engine. The weight in working order was slightly more than 24 tons, of which the driving wheels carried 10 tons. To allow of a wide fire-box, the inside frames terminated at the front of the casing, the throat plate being flanged outside to overlap the frame. The feed pumps were fixed to the outside frame and actuated by connecting-rods fixed in the boss of the driving wheels. Unlike Gray's engine, which had the designer's "horseleg" motion, the "Jennys" had Stephenson link motion, suspended on one side only. A sectional drawing of the class appeared in *The Engineer*, March 6th, 1896.

An engine similar to the "Jennys" was T. Hackworth's "Sanspareil," which came out in

23¾ tons, of which 11 tons 4 cwt. rested on the driving wheels. Further particulars of this engine and of the peculiar slide valves with which it was fitted are to be found in "Timothy Hackworth and the Locomotive," by Robert Young. The "Sanspareil" was purchased by the York, Newcastle and Berwick Railway, and ran for many years on the North-Eastern Railway.

Another express engine for the same railway, also with mixed framing, was built by R. Stephenson and Co. in 1849, and is described in their "Century of Locomotive Building." The cylinders, 16in. by 20in., were inside, but the steam chests were outside, and the excentrics were placed outside the driving wheels. This arrangement, which has appeared from time to time in locomotive design, had the fault that the steam chests were exposed to the current of cold air, and consequently liable to crack, and in the particular design under consideration the exhaust

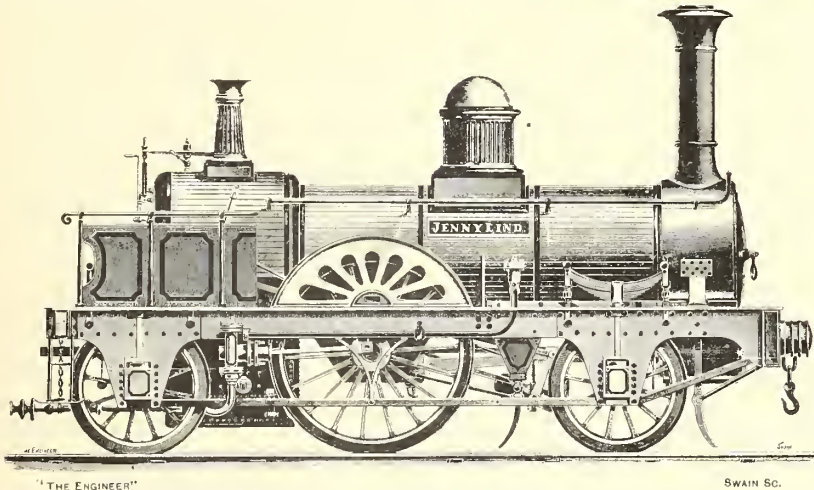

FIG. 77.—"JENNY LIND," BUILT BY E. B. WILSON & CO., 1847

December, 1849, and was the last locomotive built by him. The "Sanspareil" is shown in Fig. 78, and the most noticeable external feature is the small number of spokes—ten—in the 6ft. 6in. driving wheels. They were of circular section and of extra sectional area, but there was a large unsupported portion of the rim between each spoke. The wheels were of solid wrought iron. The outside frame was welded throughout, though this was by no means the first example of welded frames. The longitudinal seams of the boiler were also welded, and the junctions with both smoke-box and fire-box casing were made by welded flanges in place of riveted angle irons. The dome was also welded, and flanged out of a single plate. The fire-box had a roof of semi-circular shape, stayed by longitudinal girders.

The cylinders were 15in. by 22in., and placed horizontally. The heating surface was 1188 square feet, but the grate had an area of only 11 square feet. Total weight in working order,

steam was carried round the bottom of the cylinders to the blast pipe, thereby extracting heat from them. The cylinders were firmly secured to both inner and outer frame plates by flanges attached to each, and they were also bolted together on the centre line of the engine. The reason for the outside steam chests and excentrics was not given, but as there was plenty of room on the crank axle for inside excentrics, the probability is that accessibility to the steam chests was the main consideration. Between 1848 and 1854, not only Messrs. Stephenson, but also the Vulcan Foundry, Jones and Potts, and R. and W. Hawthorn built a number of engines with outside steam chests, though in the case of Hawthorn's engines the reason for the design was different.

The boiler of the Stephenson engine described above was slightly oval, having a vertical diameter of 3ft. 10in., and a horizontal one of 3ft. 9in., but it was not stayed transversely. The driving wheels were 6ft. 7in. diameter, and the

total wheel base 14ft. 6in. In this connection it may be noted that the short wheel bases of two or three years earlier were now discarded. Another point of interest is that the boiler centre was 6ft. 6in. above rail level, and showed that Messrs. Stephenson had seceded from the advocates of a low centre of gravity. It is significant

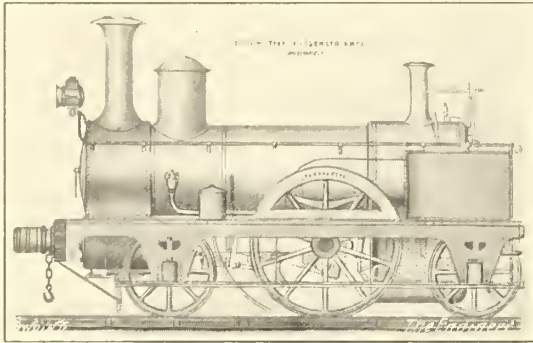

FIG. 78—F. HACKWORTH'S "SANS-PAREIL," YORK, NEWCASTLE & BERWICK RLY., 1849

that Robert Stephenson, during the discussion on Crampton's paper (Inst. C.E., 1849) stated that he "had travelled with the utmost steadiness on an engine of which the centre of gravity was as high or higher than any he had previously seen, and he therefore denied that the steadiness of an engine was entirely caused by an extremely low centre of gravity."

The inside frames, with which the driving horns were forged solid, extended from the front buffer beam to the front of the fire-box casing, but there were brackets riveted to the front of the casing, with plates which embraced the ends of the inside frames, and allowed for expansion of the boiler. A somewhat similar arrangement was embodied in Hackworth's "Sanspareil," but the latter was in one respect better in that the draw bar was attached to a pin through a short drag-box under the footplate, whereas in Stephenson's engine the pull was taken directly from the fire-box by means of an angle iron riveted to the casing. Stephenson's engine weighed 25½ tons in working order, of which 11 tons were on the driving wheels.

The weight distribution of all these later 2-2-2 engines had been considerably improved, since the proportion of weight on the driving wheels was reduced from about 50 to about 43 per cent. of the total, and the leading wheels were more favourably loaded.

The firms of Sharp Bros., W. Fairbairn and Sons, and R. and W. Hawthorn did not depart from the type with outside sandwich frames and bearings for their passenger engines. Hawthorn's 7ft. 2-2-2 express engine "Plews" for the York, Newcastle and Berwick Railway is illustrated by Fig. 79. The steam chests were outside, as in Stephenson's engine above, but were

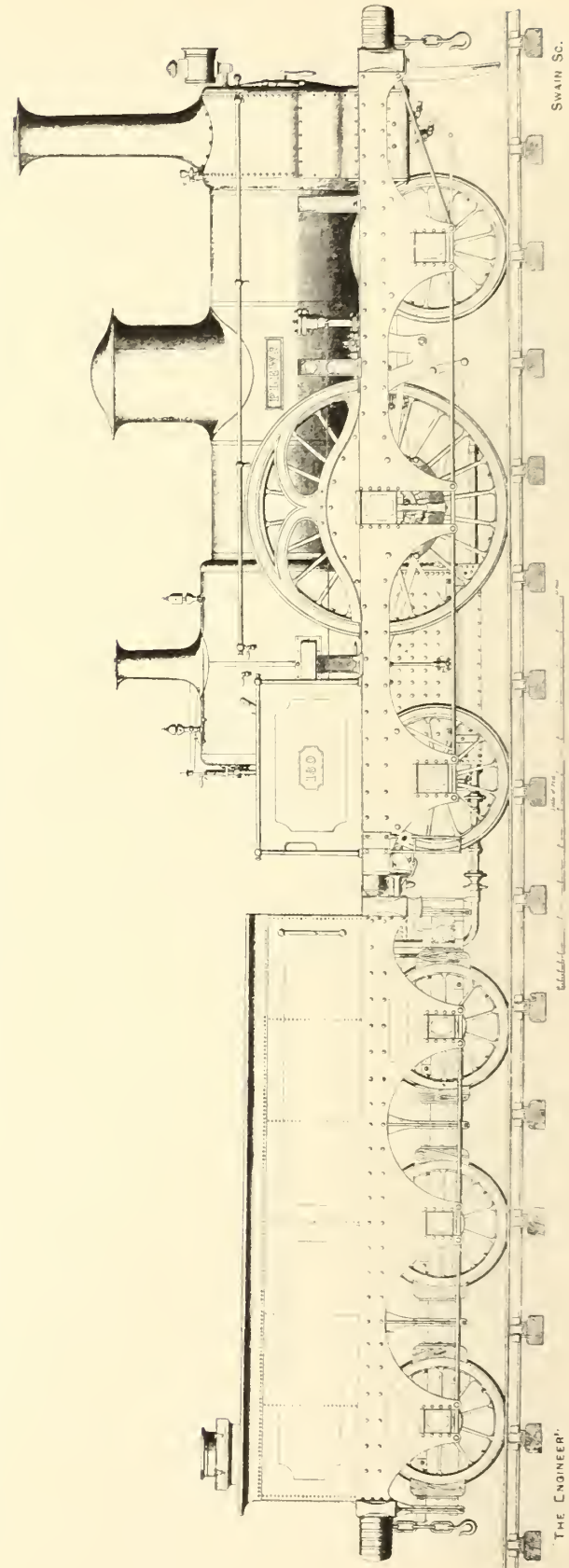

FIG. 79—THE "PLEWS," YORK, NEWCASTLE & BERWICK RLY., BUILT BY R. & W. HAWTHORN, 1848

SWAIN SC.

THE ENGINEER

placed between the inside and outside frames, the eccentrics being outside the driving wheels and inside the outer frames. In this case the object was to keep the boiler, which was oval in section, as low as possible. To this end the

and built at Crewe in 1847 the "Velocipede" with 7ft. wheels and 15½ in. by 20 in. cylinders, but the largest engines of the type were to be found on the L. and S.W.R. One of these, designed by J. V. Gooch, was built in 1848. The

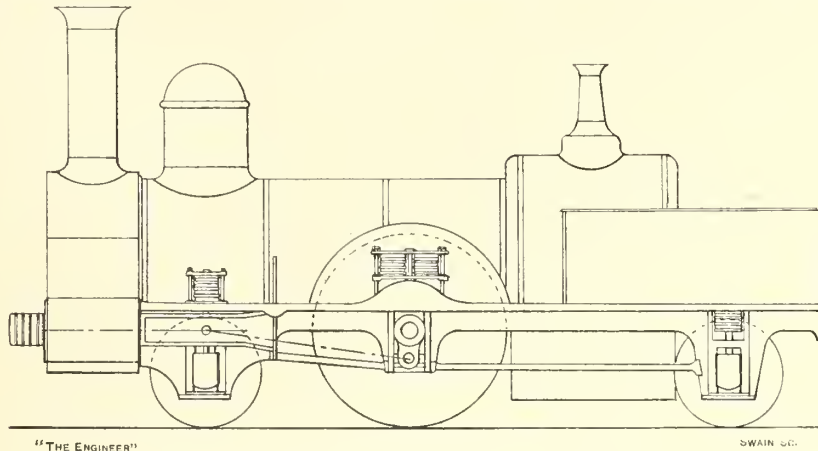

FIG. 80—McCONNELL'S L. & N.W. RLY. ENGINE, 1849

cylinder centres were 3ft. 9in. apart and the outside webs of the cranks were placed against the driving wheel bosses. The two inside bearings were between the cranks. The steam chests were hidden behind the outside frames, and to render the valves accessible were fitted with end instead of side covers. The sides of the oval boiler were stayed across by thin plates in place of tie rods.

cylinders were 16in. by 22in. and the driving wheels 6ft. 6in. diameter. A number were built in 1849-50 with 7ft. driving wheels. They followed the general lines of the earlier engines of 1843 mentioned previously. Of the type with inside bearings for all wheels, similar to that on the Glasgow and Ayr and other Scotch railways, the Lancashire and Yorkshire standard passenger

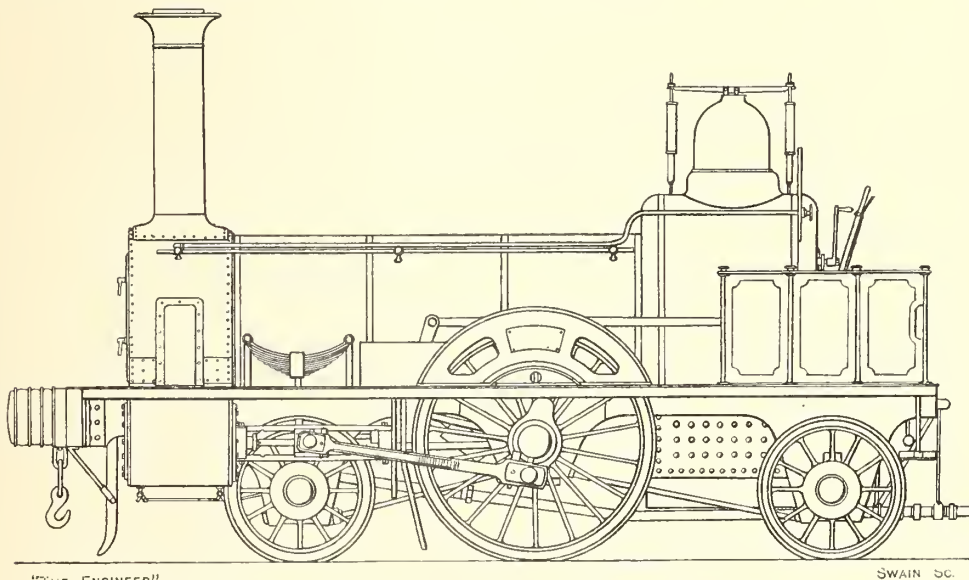

FIG. 81—LANCASHIRE AND YORKSHIRE RLY. ENGINE, 1849

The "Plews" started work in December, 1848, and Stephenson's engine in January, 1849.

Outside Cylinder Engines.—The development of this type was generally on the lines of the Crewe engine with mixed frames. Allan designed

engine is shown by Fig. 81. These were designed by Hurst under John Hawkshaw's supervision.

One remarkable 2-2-2 express engine—Fig. 80—designed by McConnell and built at Wolverton in 1849, deserves mention. It was an extreme

development of Forrester's "boxers," in which outside frames and driving bearings were combined with outside cylinders. The latter were 18in. diameter by 21in. stroke, and as a result of the frames being outside were spaced so far apart that they did not clear the structural gauge,

the fire-box with transverse partition provided 138 square feet. The total weight in working order was 31 tons 19½ cwt., of which the driving wheels carried 13 tons 19½ cwt. The springs throughout were formed of large india-rubber pads separated by metal discs, those for the driving bearings

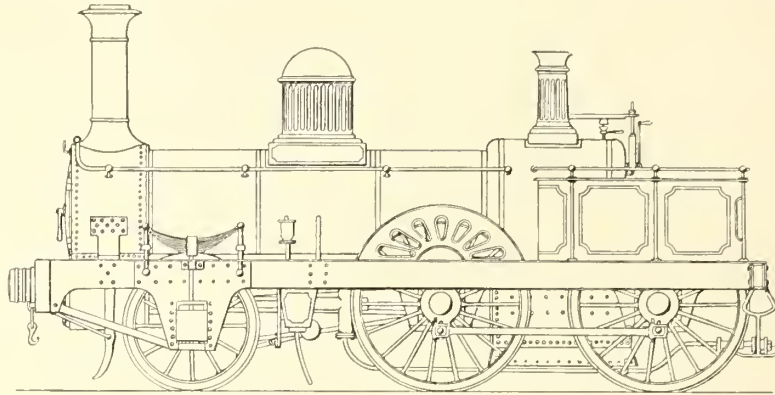
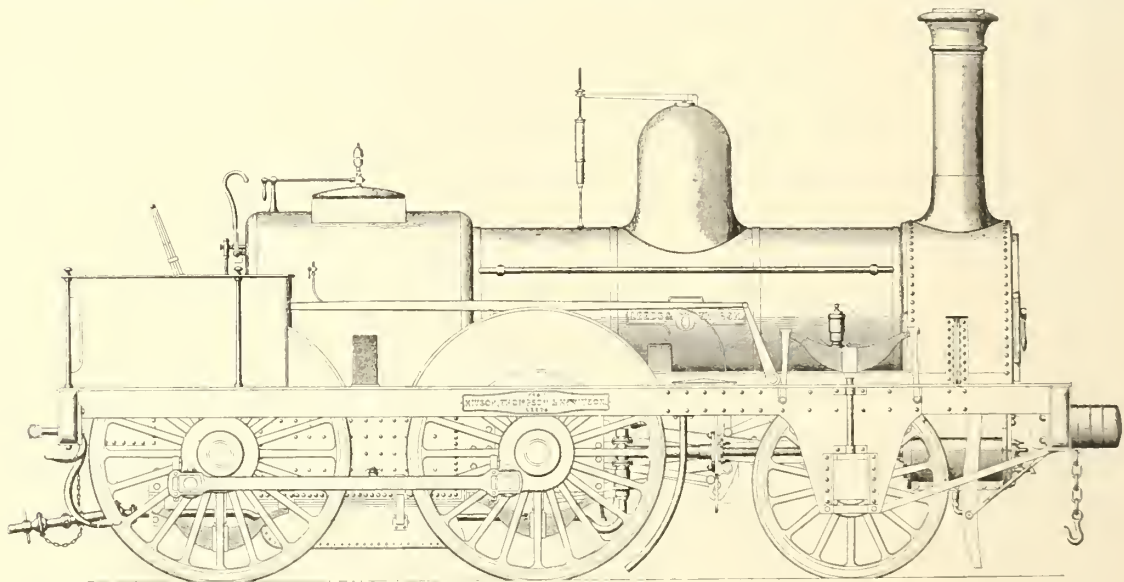

FIG. 82—E. B. WILSON & CO.'S PASSENGER ENGINE OF 1848

so that some of the station platforms had to be altered. For this reason the engine was known as "Mac's Mangle." The driving wheels were 6ft. 6in. and the carrying wheels 3ft. 9in. diameter. The total wheel base was no less than 17ft. 2¼in., but to clear the cylinders the leading

being double. This form of spring was frequently used by McConnell.

"Mac's Mangle" was the last British standard-gauge engine with outside cylinders and bearings, but this combination became very common on Austrian and South German railways, on which it



"THE ENGINEER"

INCHES 12 6 0 1 2 3 4 5 6 7 8 9 10 FEET

SWAIN SC.

FIG. 83—KITSON, THOMPSON & HEWITSON'S LEEDS AND THIRSK RLY. ENGINE, 1849

wheels were placed so far back that the weight at the front was excessive, and the large dome had subsequently to be moved from the front to the back ring of the barrel as a makeshift remedy. The boiler contained 189 2¼in. tubes and had a total heating surface of 1539 square feet, of which

was developed by Maffei, Haswell, Kessler, and others.

Four Wheels Coupled Passenger Engines.—The majority of these engines were of the long boiler outside cylinder type, but in 1848-9 inside cylinder engines with the trailing axle behind the

fire-box came into more extensive use. The type was derived from Stephenson's engine of 1837—Fig. 38 *ante*. Some four-coupled passenger engines by R. Stephenson and Co., 1848-9, for the York, Newcastle and Berwick Railway, had 6ft. coupled wheels and inside cylinders, 15½in. by 22in. The steam chests were outside and the eccentrics were placed between the driving wheels and the outside frames. The driving tires were flangeless. "Gothic" fire-box casings, then dying out, were used on these engines.

In 1848 E. B. Wilson and Co. introduced the mixed-framed 2-4-0 engine with outside bearings for the leading wheels only. This was directly derived from the "Jenny Lind" type by substituting coupled wheels with inside bearings for the small carrying wheels of the latter. An engine of this class is shown by Fig. 82.

Six fine engines of this type—Fig. 83—were

engines had to be altered. Full particulars with drawings of these engines are contained in Clark's "Railway Machinery."

Goods Locomotives.—The most notable six wheels coupled goods engines of the period—Fig. 84—were built 1846-49 by Sharp Bros. for the Manchester, Sheffield and Lincolnshire and the London and North-Western railways. They were of Stephenson's long boiler type of greatly increased power. The cylinders were inside, 18in. diameter by 24in stroke, placed at 2ft. 3in. centres. The valves, which were underneath but inclined upwards towards the back, were actuated by direct link motion with valve rods suspended by long swing links from the bottom of the boiler. In these engines we now meet with the solid inside frame in one piece from front to back buffer beams with axle guards welded on. This was one of the greatest improvements of the period and is

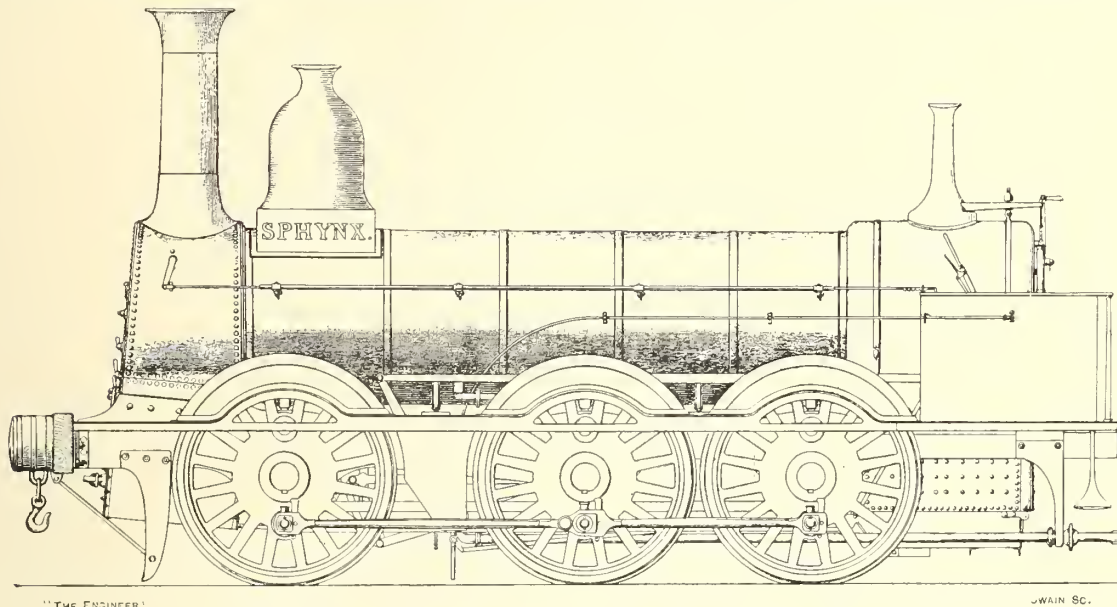

FIG. 84—SHARP BROTHERS' M.S. & L. RAILWAY ENGINE, 1849

built in 1849 by Kitson, Thompson and Hewitson for the Leeds and Thirsk Railway, and for thirty years worked the fast passenger trains between Leeds and Hartlepool. They had 16in. by 22in. cylinders, 6ft. coupled wheels, wheel base 15ft. equally divided, and total heating surface 873 square feet, of which the fire-box provided 90 square feet. The boiler centre was 6ft. 2½in. above rail level. Weight about 26 tons.

The plain welded sheet iron dome covers were a feature of Kitson's practice, introduced about 1848, from which the modern dome covers of to-day are direct derivatives. The reversing gear was arranged so that when the engine was in fore gear the reversing lever was at the back. This was a not uncommon practice with several makers, but was a constant source of confusion to the drivers, and in later years the gear of many such

stated to have been due to C. Beyer, then head of the designing department of Sharp Bros. Messrs. Stephenson had welded axle guards on inside frames in 1832, but these were short frames extending between smoke-box and fire-box casing only—see Warren, pages 280-281.

In these first Sharp engines of 1846 the coupled wheels were 4ft. 6in. diameter and the wheel base 11ft. 8in., but in the subsequent engines the wheels were enlarged to 5ft. and the wheel base lengthened to 6ft. 11in. + 5ft. 3in. = 12ft. 2in. The boiler had an inside diameter of 3ft. 8in. and contained 133 2½in. brass tubes, 14ft. 3¼in. long. The fire-box had a transverse partition. Total heating surface 1148 square feet, grate area 10.6 square feet, weight in working order 26½ tons.

The cast iron wheels had balance weights solid with the bosses. The boiler was rigidly secured

to the motion plate, but at the back end was supported on the inside frame by means of the now usual form of expansion bracket.

J. E. McConnell adopted this design, almost in its entirety, for the main line goods engines of the Southern Division of the L. and N.W.R., for which line they were built until 1855 by a number of firms, but except those built by Sharp Bros., they had wrought iron wheels.

One of the early engines with 4ft. 6in. wheels was tested in 1846 between Longsight and Crewe with a trial train of 101 wagons weighing 597 tons, with which it covered the distance of about 28½ miles at an average speed of 13.7 miles per hour.

Charles Todd, who had left the Railway Foundry and started locomotive building in 1846 at the Sun Foundry, Leeds—now the works of Hathorn, Davey and Co.—built a number of goods engines with solid cast iron disc wheel centres. They ran on the York and North Mid-

Total heating surface 1001 square feet. Their chief characteristic, which they had in common with the 2-4-0 express engines—Fig. 83—was that the main frame plates at the trailing end were bolted on to the outside of the frame plates which extended from the front buffer beam to the fire-box casing, and themselves formed a portion of the latter. The lower portions of the side water spaces were therefore bounded by the fire-box copper plates inside and the frame plates on the outside, the stays being riveted over outside the latter. The joint between the front and back plates of the casing and the frame plates were made by angle irons. The arrangement provided a wide fire-box—3ft. 7¾in. inside—with 3in. water spaces, but was objectionable in that no “breathing” was possible.

There was also in 1847-8 a revival of the 0-6-0 engine with outside frames and trailing wheels behind the fire-box, a type which had originated with Stephenson’s Leicester and Swannington

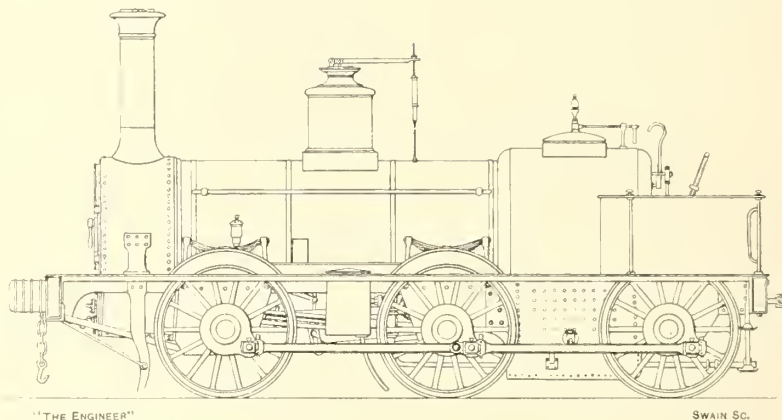

FIG. 85—KITSON, THOMPSON & HEWITSON'S ENGINE, LEEDS & THIRSK RLY., 1848

land and Great Northern railways. In addition to the defect of increasing the non-spring-borne weight, they were said to have rumbled noisily over the track.

What may be termed the standard British 0-6-0 goods engine with inside cylinders and frames and the trailing axle behind the fire-box appeared on the 4ft. 8½in. gauge for the first time in 1848, when Kitson, Thompson and Hewitson, of Leeds, and B. Hick, of Bolton, built the type simultaneously. Hick's engines, which were illustrated in *The Engineer*, June 25th, 1920, were not of such up-to-date design as those of Kitson. Hick's engines had the old gab motion and were almost the last main line engines in this country to be fitted with it.

Kitson's engines for the Leeds and Thirsk and Midland railways—Fig. 85—had link motion. The cylinders were 17in. by 24in. and the wheels 4ft. 9in. diameter. Wheel base 15ft. 6in., equally divided. The boiler barrel, 11ft. long by 3ft. 8¼in. diameter, contained 162 1¼in. tubes, the heating surface of which was 908 square feet.

engine of 1834. Most of the new engines were built by R. Stephenson and Co. and E. B. Wilson in 1847-8. It is probable that the general design was due to Matthew Kirtley, of the Midland Railway, and both Stephenson's and Wilson's engines had the old clumsy arrangement of cylinders inclined upwards, and slide bars below the leading axle. Why this design was not discarded in favour of the much more mechanical arrangement used since 1843 in Stephenson's long boiler goods engines is a mystery, and the engines proved so troublesome in service that their average life did not exceed more than ten to twelve years. There were several similar engines by E. B. Wilson on the Great Northern Railway, which Archibald Sturrock reconstructed on orthodox lines.

Goods Engines with Outside Cylinders: Scottish Types.—The Caledonian and Scottish Central railways in 1847 adopted outside cylinders for goods engines, which were mostly of the 0-4-2 type originated by J. and G. Rennie in 1839—Fig. 42 *ante*. The general design was due to

Robert Sinclair, and the first engines were built by Jones and Potts and the Vulcan Foundry. These had 16in. by 18in. horizontal cylinders, 4ft. 7in. coupled wheels, 3ft. 6in. trailing wheels, total heating surface 953 square feet, and grate area 14 square feet. A number of 0-6-0 goods engines were also built by Jones and Potts for the Caledonian Railway with outside cylinders, 17in. by 24in., but the latter type never established a footing on British railways. Mr. Sinclair subse-

der engines with single driving wheels for the Manchester and Birmingham Railway, for service on the Macclesfield branch. The horizontal cylinders were 15in. by 20in., the driving wheels 5ft. 6in. diameter, and the pressure 120 lb. One tank was underneath the boiler, between the leading and driving wheels, and the other underneath the coke bunker at the back. Their total capacity was 480 gallons. The frames extended from the front to the back buffer beam, and all

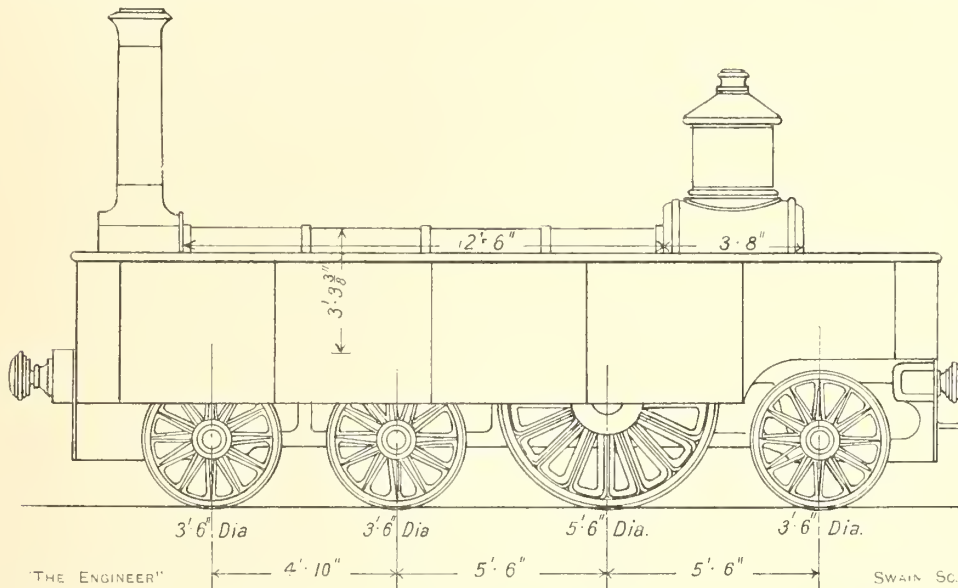

FIG. 86—TAYLEUR'S TANK ENGINE FOR WATERFORD AND KILKENNY RAILWAY, 1846

quently converted them to 0-4-2 engines, at the same time reducing the cylinders to 17in. by 20in. Particulars of C.R. Nos. 124 to 127 in their original condition with six-coupled wheels are given on pages 130-1, and a diagram No. 35 on plate VI., Part 2, of Clark's "Railway Machinery."

Passenger Tank Engines.—Tank engines for local traffic, of which there had been only a few early examples by Forrester on the Dublin and Kingstown and the London and Greenwich railways, again appeared in Ireland in 1846, when C. Tayleur and Co. supplied three side tank engines of very unusual design—Fig. 86. The engines had very deep and long side tanks, and to distribute the weight four axles were provided. The cylinders, 14in. by 20in., were inside, and the third pair of wheels, 5ft. 6in. diameter, with T iron spokes, were the drivers. The carrying wheels, 3ft. 6in. diameter, had V bar spokes. The wheel base, 15ft. 10in., was rigid. These were the earliest *side* tank engines, and their existence disposes of a claim which has frequently been made on behalf of Crewe works to priority of this type. The driver was apparently expected to oil the motion by getting underneath the engine.

In 1847 Sharp Brothers built two outside cylin-

wheels had inside bearings only. Brake blocks were placed at the back of the driving and in front of the trailing wheels, and were actuated by a vertical screw and toggle joint. The wrought iron driving wheels had balance weights in the rims. These were formed of cast iron blocks held in place by wrought iron plates, and balanced the revolving masses only. These engines, with their details, were fully described and illustrated in Tredgold's "Steam Engine" (1850 edition).

The London and Blackwall Railway tank engines, by Jones and Potts in 1848, were of the outside cylinder type, with 5ft. 6in. single driving wheels—Fig. 87. The inclined cylinders were

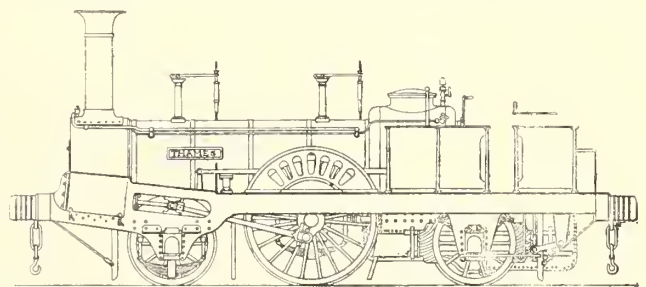

FIG. 87—JONES & POTTS ENGINE, "THAMES," LONDON & BLACKWALL RLY., 1848

originally 13½ in. by 18 in., but were subsequently enlarged to 14 in. by 20 in. These engines were of Allan's "Crewe" type, with outside bearings for the carrying wheels, but the tanks were placed underneath the trailing end. Their total weight was slightly over 22 tons.

Steam Motor Coaches.—Steam carriages for branch lines were introduced in 1847 by W. Bridges Adams, though the idea of the first one appears to have been due to Mr. Samuel, engineer of the Eastern Counties Railway. This was an inspection engine, which with open carriage, tanks, and vertical boiler on the same frame, ran on four wheels. An illustration appeared in Colburn's "Railway Machinery," page 75, and more complete drawings in Tredgold's "Steam Engine" (1850 edition).

In 1848 Mr. Adams built at his works at Bow

the ordinary locomotive type, had a total heating surface of 255 square feet and carried 120 lb. pressure.

The long combined engine and coach was found to be inconvenient in service, and subsequently they were separated. Later, in 1849, Mr. Adams built the "Cambridge" for the Eastern Counties Railway. This was an independent 2-2-0 engine, to which one or two light carriages could be attached in the ordinary way. This type of light engine, of which an illustration appears in Colburn, page 75, was frequently used in Ireland, for the railways of which Messrs. Stephenson and Kitson built a number. The outside cylinders were placed behind the leading wheels, and the single driving wheels were in front of the fire-box. The tanks were carried beneath the boiler, and to produce a steady engine the wheel base was of

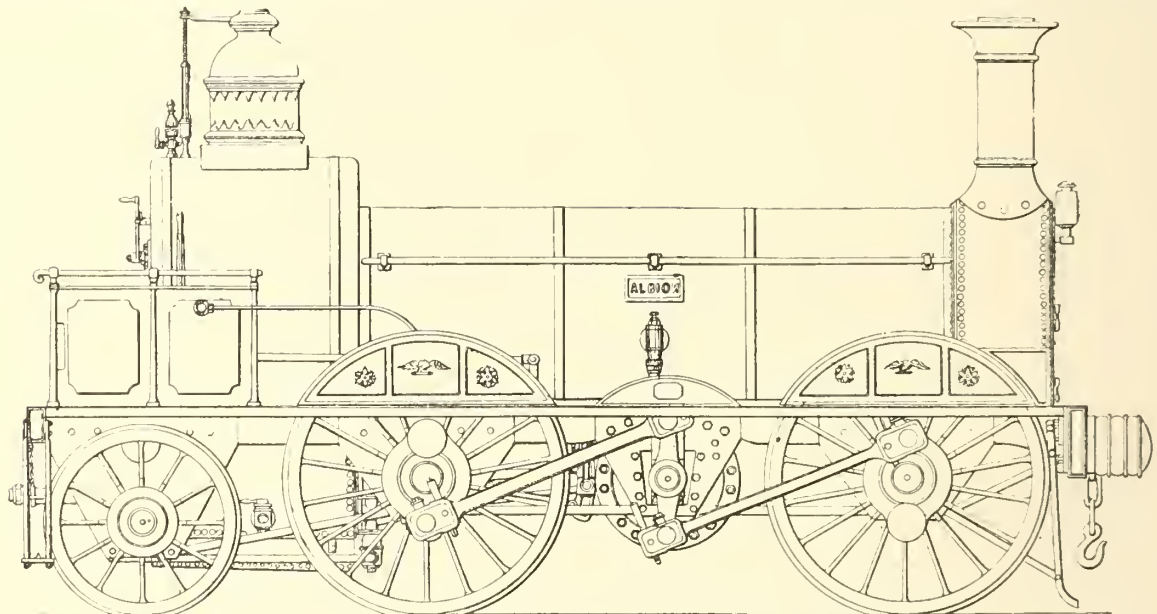

FIG. 88.—THE "ALBION," SOUTH YORKSHIRE RLY., BUILT BY THWAITES BROS., 1848

a larger combined motor coach for the Bristol and Exeter Railway (7ft. gauge). This engine, the "Fairfield," had single driving wheels, 4ft. 6in. diameter, in front, which were driven through a dummy crank shaft, actuated by inside cylinders, 7in. by 12in. The shaft was connected to the driving wheels by outside coupling-rods. The boiler was of the vertical type. The engine and carriage were on the same frame.

In the "Enfield," built in January, 1849, for the Eastern Counties Railway, the engine was of the 2-2-0 outside cylinder type, and the carriage also ran on four wheels, the whole being combined on one frame. This arrangement produced a vehicle with very long wheel base, and to accommodate the curves, only the leading engine wheels and trailing carriage wheels had flanges. The cylinders were 8in. by 12in., and the driving wheels 5ft. diameter. The boiler, which was of

considerable length. One of Stephenson's engines for the Londonderry and Enniskillen Railway, with 11in. by 18in. cylinders, 5ft. driving wheels and 10ft. 4in. wheel base, was illustrated in Clark's "Railway Machinery," plate 28.

"History repeats itself." When motor coach engines were reintroduced in this country in 1903-7, the types passed through similar combined and separated types, and then, with a few exceptions, died out just as rapidly.

Miscellaneous Locomotives.—The briefest mention may be made of Crampton's patent locomotive, "Lablache," built by E. B. Wilson in 1847, which ran upon four 6ft. wheels, driven by means of an intermediate oscillating shaft. There is no necessity to describe it here. Those interested will find fuller particulars and illustrations in *The Engineer*, March 12th, 1880, page 191. Also see Colburn—page 79—who gives the wheels as

6ft. 6in. A drawing dated March, 1848, shows 6ft.

Another "freak" engine, the "Albion," is illustrated by Fig. 88. This was a six-wheeled engine, of which the two leading pairs were driving wheels. They were driven by intermediate oscillating shafts, but the chief feature was a

transverse cylinder with vibrating vane pistons, the rods of which issued laterally and formed the driving shafts. The engine was built in 1848 by Thwaites Brothers, of Bradford, and ran for fourteen or fifteen years on the old South Yorkshire Railway.

Chapter VIII—1849-55

I NTERMEDIATE DRIVING SHAFT LOCOMOTIVES.—Between 1848 and 1855 there was a revival of designs, in which the connecting-rods drove an intermediate or so-called “dummy” shaft. These included not only locomotives with inside cylinders and shafts of the crank axle type, but also outside cylinder engines with straight

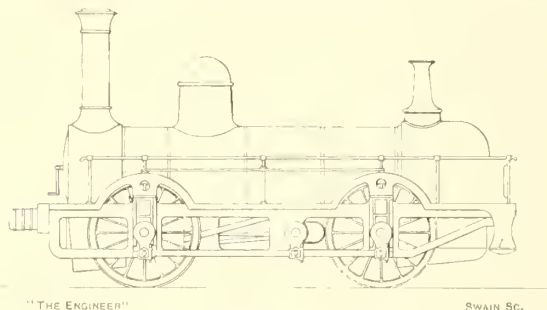

FIG. 89—VULCAN FOUNDRY LOCOMOTIVE, SHREWSBURY & CHESTER RLY., 1848

shafts and outside driving cranks. The original Wylam engines were of this general type, but the drive was conveyed from the shaft to the wheels through spur gearing. The drive through coupling rods appeared in 1830 in Hackworth's mineral engines of the “Majestic” and “Wilberforce” classes, with six coupled wheels, and in others with the intermediate shaft placed midway between four wheels, such as Galloway's “Caledonian” of 1832 and Hawthorn's “Swift” of 1836. All these engines had outside vertical cylinders.

The engines of the 1849-55 period had cylinders placed horizontally, or nearly so, and the chief consideration which prompted their design was the avoidance of the “nipping” of, and the lateral blows on, the flanges of driving wheels,

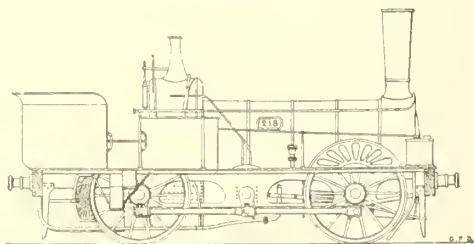

FIG. 90—CRAMPTON TANK LOCOMOTIVE, BY E. B. WILSON & CO., AMBERGATE, NOTTINGHAM, B. & E. J. RLY., 1851

which caused sudden bending stress on the axles. Moreover, the crank shaft, like that of a stationary engine, did not rise and fall with the springs, and it was contended that the steam distribution was consequently unaffected. On the other hand, the weight in the coupled engines of

this type was carried on four wheels, which resulted in a greater load per axle. With the exception of Wilson's small engines, the others were used for mineral traffic, frequently on lines on which the track showed considerable inequalities. Under these conditions, these coupled engines ran very steadily. They have frequently been referred to as “Cramptons,” but his patents could hardly claim the design as new, since it had undoubtedly been anticipated in Galloway's engine of 1832.

The first of the new type were tender engines with inside cylinders and outside frames, and were simultaneously designed in 1848 by Messrs. Hawthorn for the Edinburgh Northern Railway and the Vulcan Foundry for the Shrewsbury and Chester Railway. The latter engine, which had 16in. by 24in. cylinders and 5ft. 3in. wheels, is shown by Fig. 89.

It was a large engine with boiler barrel 13ft. 4in. long, and of oval section, 4ft. 2½in. vertically by 3ft. 6½in. horizontally. The total heating surface was 1293 square feet. The wheel base was 11ft. 5in., and the crank shaft was placed

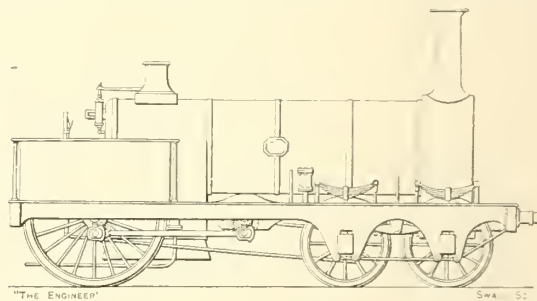

FIG. 91—INSIDE CYLINDER “CRAMPTON” ENGINE, G.N.R., 1851

7ft. 4in. behind the leading axle. There were four elliptical springs enclosed within casings above each bearing. No record of the weight appears to have been kept.

A number of small tank engines with inside bearings were built in 1850-1, by E. B. Wilson and Co., Leeds. The cylinders were 11in. by 18in., and the wheels 5ft. diameter. Heating surface, 576 square feet; pressure, 100 lb. The tanks of some of the class had a capacity of 400 gallons. One of these little engines is shown in Fig. 90.

The last inside cylinder engines of this type in this country were built by R. Stephenson and Co. in 1851 for the Folkestone Harbour branch of the S.E.R. These were tank engines with 16in. by 24in. cylinders and 4ft. 6in. wheels, of which the axle bearings were inside. Between the frame and the outside driving cranks the eccentrics for actuating the pump rods were placed. The cylin-

ders were awkwardly arranged with an upward inclination towards the back and slide bars below the leading axle. Wheel base 12ft. 4in.; and total weight in working order 26 tons. The only brake power was provided by wooden blocks on the backs of the trailing wheels. Subsequently the

leading wheels, and differed from the G.N.R. engine, which had independent springs for each pair of wheels, connected by compensating levers. The driving spring behind the fire-box was of the single transverse type placed in a box across the footplate, so that both classes had three-point

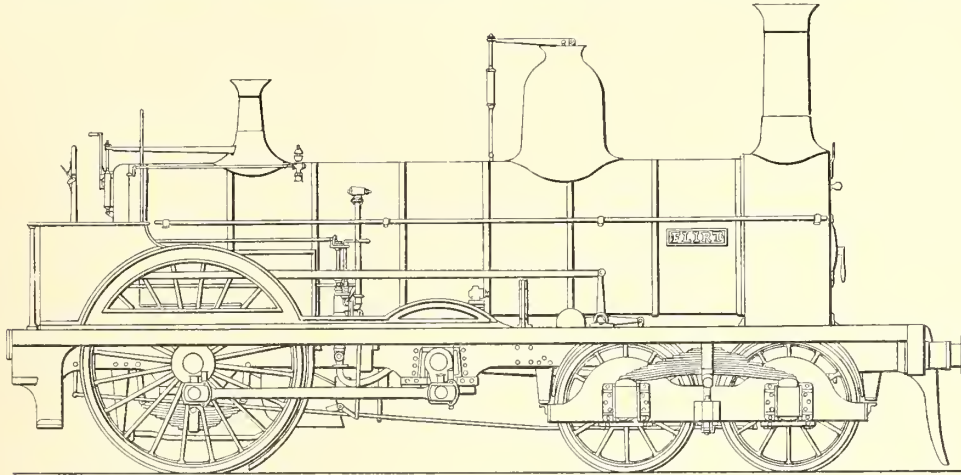

"THE ENGINEER"

SWAIN Sc.

FIG. 92—LOCOMOTIVE FOR THE LONDON, CHATHAM & DOVER RLY., 1862

engines were converted to 0-6-0 tank engines—see *The Engineer*, July 1st, 1910.

In 1849 Crampton took out a patent for express locomotives with intermediate crank shaft and single driving wheels placed behind the fire-box. In 1851 a number of these were built by R.

suspension. The cylinders of the S.E.R. engines were 15in. by 22in.; driving wheels, 6ft. diameter; carrying wheels, 3ft. 6in. diameter; total wheel base, 16ft. The centre of the driving shaft was 7ft. in front of the driving axle, and 4ft. 6in. behind the second carrying axle. The driving

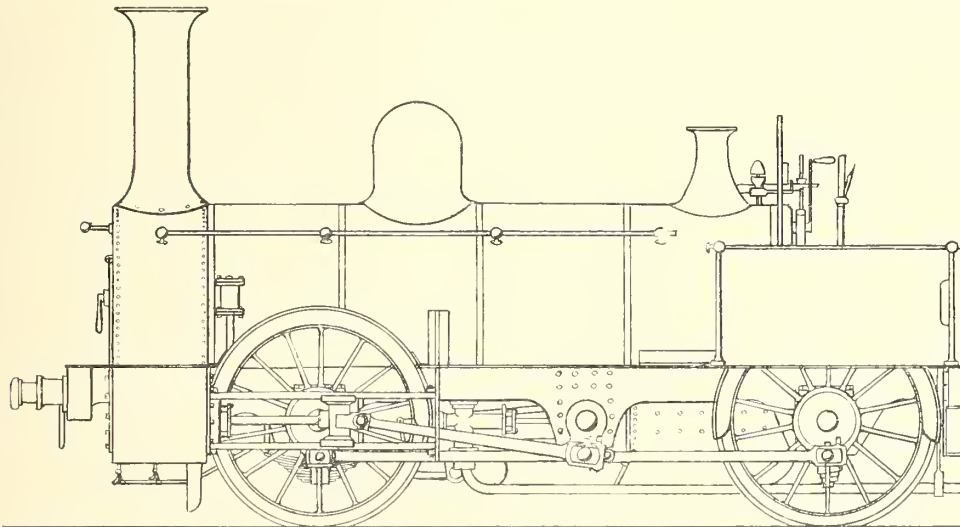

"THE ENGINEER"

SWAIN Sc.

FIG. 93—P. STIRLING'S ENGINE FOR THE GLASGOW & SOUTH WESTERN RLY., 1855

Stephenson and Co. for the S.E.R., and by R. B. Longridge and Co. for the G.N.R. Both series were of generally similar appearance—as shown by Fig. 91. The boilers were domeless, with the flush topped fire-box casing, long advocated by Crampton. The ten S.E.R. engines had a single inverted spring on each side for the two pairs of

shaft had bearings fitted with wedges both at the front and back, the axle-boxes being of brass. The tube heating surface was 1059 square feet, and the total 1153 square feet. Weight in working order $26\frac{1}{2}$ tons, of which only 10 tons were carried on the driving wheels.

The Great Northern engines had 6ft. 6in

driving wheels and 15in. by 21in. cylinders. It has hitherto been accepted that the G.N.R. had ten of these engines, Nos. 91 to 99 and 200, but the writer has recently found a letter from Mr. Sturrock, in which he stated definitely that there was only one "Crampton" on the line, and that the others were not of this type, but of his—Sturrock's—own design. This would refer to Nos. 91 to 99, which were of the 2-2-2 type, probably built originally as such. The form in which No. 200 was rebuilt seems to bear out the view that this was the only intermediate shaft engine.

In this design Crampton had to discard the low-pitched boiler, one of the principal considerations which decided his earlier outside cylinder design. To clear the inside crank shaft the boiler centre of the S.E.R. engines was placed 6ft. 5½in. above rail level. There were also two rebuilt engines on the Brighton Railway of a similar type—see *The Engineer*, July 1st, 1910.

The intermediate crank shaft reappeared in 1862 in five express engines—Fig. 92—built by Stephenson and Co. on Crampton's recommendation for the London, Chatham and Dover Railway, but in these a leading bogie was substituted for the two independent rigid leading axles. The rear driving wheels were placed further forward underneath instead of behind the fire-box, the long sloping grate of the latter permitting this modification. The driving wheels were 6ft. 6½in. diameter, and the cylinders 16in. by 22in.; bogie wheels, 4ft. 0½in. diameter; bogie wheel base, 4ft. 9in. The bogie pivot was 7ft. 10½in. in front of the crank shaft, and the centre of the latter 7ft. 3½in. from the centre of the driving axle. Total heating surface was 1198 square feet, of which the fire-box, of the Cudworth type, provided 129 square feet. The boiler centre was 6ft. 9in. above rail level.

None of the above intermediate shaft express engines were successful. Compared with the older outside cylinder Crampton engines, they suffered from the defect of having the smaller driving wheels too lightly loaded. In the earlier outside cylinder engines large driving wheels, 7ft. to 8ft. diameter, were usual, and the weight of these materially increased the adhesion, though with the accompanying disadvantage of a greater non-spring-borne weight. The G.N.R. engine, after a few years' service, was altered by A. Sturrock to the ordinary 2-4-0 type with middle driving wheels. The S.E.R. engines ran in their original condition until 1869, when J. I. Cudworth converted most of them to 2-4-0 engines. One only, No. 142, was provided in 1856 with a Cudworth patent fire-box for the purpose of experimental trials, but otherwise lasted in its original condition until 1874. The later L.C. and D.R. engines were also converted by W. Martley into 4-4-0 engines with double frames, the original bogies being retained.

The remaining type of intermediate crank shaft

engines, which had *outside* horizontal cylinders, was introduced on the Caledonian Railway by R. Sinclair in 1853-54, and consisted of both tank and tender engines of moderate size for branch line mineral traffic. Patrick Stirling was the last engineer to design this type, and one of four engines for the Glasgow and South Western Railway, for which he was responsible, is illustrated in Fig. 93. These were built early in 1855 by R. and W. Hawthorn, and had 5ft. wheels and 15in. by 20in. cylinders. They had a short life of about twelve years and then disappeared.

Uniflow Locomotive, 1849.—Following the work of Bodmer, Crampton, Fernihough, and others in trying to improve the stability of locomotives, other engineers turned their attention to the work of the steam in the cylinders. Foremost amongst these were Daniel Gooch and D. K. Clark, whose labours have been so fully recorded in the standard book, "Railway Machinery," by the latter, that nothing need be added here.

That a uniflow locomotive worked for about three years on the South-Eastern Railway is not so generally known. A short account of it was given in the *Railway Magazine* of June, 1907, before the Stumpf locomotive had appeared, and it was also referred to in a letter to *The Engineer*, April 25th, 1913, page 450. The uniflow stationary engine was proposed in this country in 1885 by T. J. Todd, who was preceded by Jacob Perkins. The S.E.R. locomotive of the 2-2-2 type was built in 1845 with ordinary 15in. by 18in. cylinders. The latter were replaced in 1849 by a new pair, the inside length of which was about twice the stroke, the latter remaining 18in. as before. The length of the piston was nearly one-half the length of the bore, and in the middle of the cylinder was an exhaust port which extended round half the circumference. When the piston had nearly completed its stroke, the steam was exhausted through the middle port into a pipe which passed round outside the cylinder barrel and entered the smoke-box from the outside on its way to the blast pipe.

Who was the originator of the idea is not known, but J. I. Cudworth was locomotive superintendent and would be responsible for its application, and also for its removal about three years afterwards. The reason for discarding it was not stated. But in the absence of balance weights for the reciprocating masses, it seems likely that the heavy pistons caused both fore and aft "surging" and excessive swaying.

Compound Locomotives.—The earliest compound locomotive was patented in 1850 by James Samuel, the engineer of the Eastern Counties Railway, though the credit of the invention was due to John Nicholson, an employee in the locomotive department. Two existing locomotives were converted in 1850-52 to the new principle, and were termed "continuous expansion" engines. They differed from a modern compound engine in that the steam was finally expanded in both

high-pressure and low-pressure cylinders. The original arrangement provided for two cylinders, of which the low-pressure had a piston about 2.3 times the area of the high-pressure. The boiler steam admitted to the latter was cut off at about half stroke, at which point the low-pressure cylinder was just beginning its stroke, the cranks being at 90 deg. A communication was then opened with the low-pressure cylinder, and the steam expanded in both cylinders simultaneously, until the communication between them was closed by the valve. At this point the steam in the high-pressure cylinder was discharged into the blast pipe, whilst that in the low-pressure cylinder, the piston of which was at mid-stroke, was further expanded down to the lowest possible pressure consistent with efficiency. The underlying idea in this method of working, apart from considerations of fuel economy, was that there should be

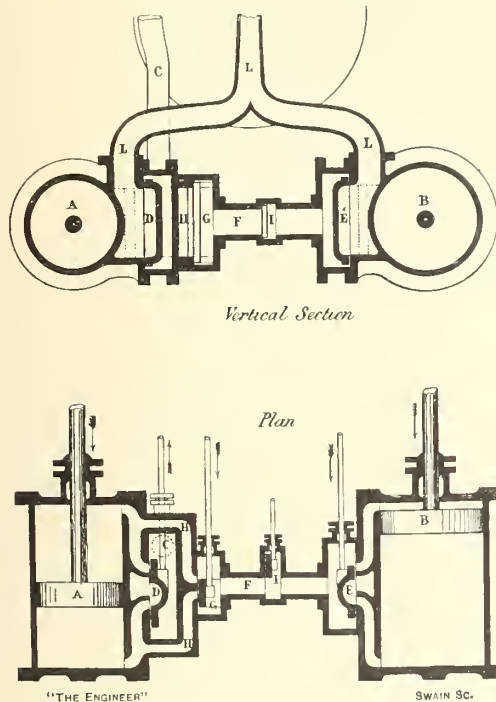

FIG. 94—CYLINDERS OF NICHOLSON'S CONTINUOUS EXPANSION LOCOMOTIVE, 1852

sufficient pressure of exhaust steam from both cylinders to maintain an effective blast. It was intended that the exhaust from the high-pressure cylinder, in quantity about 44 per cent. of the steam admitted, should escape at about 30 lb. per square inch, and that of the low-pressure cylinder at as low a pressure as possible, about 5 lb. per square inch.

The diagram—Fig. 94—taken from the Proc. Inst. Mech. E., 1852, shows the arrangement applied to an outside cylinder engine. Steam from the pipe C was admitted to the high-pressure cylinder A by the slide valve D. At half stroke

the supplementary slide valve G, controlled by a fifth excentric, was opened and allowed the steam to exhaust through passages H and F into the low-pressure steam chest containing the slide valve E. A starting valve I was provided by which the driver could close the passage F. This was non-automatic, and at the same time an additional cock had also to be opened to admit boiler steam into the low-pressure cylinder. By this arrangement the engine could be worked non-compound whenever extra power was required.

It was intended to use steam of 160 lb. pressure, but as the two engines which were fitted with the arrangement had old boilers, there is no doubt that the boiler pressure did not exceed 100 lb. to 110 lb. Moreover, in one of them—a 2-4-0 for goods traffic—the high-pressure and low-pressure cylinders were of the same size, 15in. by 24in., and consequently the “compound” system was applied at a great disadvantage. The reason for this appears to have been that it was feared that the blast might prove insufficient, and it was decided to test this experimentally before going to the expense of a large low-pressure cylinder. It was stated that 12 lb. of coke per mile were saved, probably largely on account of the inefficiency of the original simple engines. As a “compound” the system had the defect that the difference between the initial and final temperatures of the steam in the high-pressure cylinder was as great as in the simple engine, since the final exhaust from this cylinder communicated directly with the atmosphere. Other causes appear to have precluded a fair locomotive trial, and Nicholson took the idea to a Mr. Stewart, who had works in London, where several stationary engines working on this continuous expansion system were subsequently built.

Passenger Tank Engines with Single Driving Wheels.—Following the combined engines and coaches of W. B. Adams, a considerable number of passenger tank locomotives were built during 1850-55 for branch line traffic, though in many cases they were used for light main line trains. The majority had single driving wheels; one or two four-coupled types will be noticed subsequently.

The outside cylinder well tank engine by Sharp, Roberts has already been mentioned. A smaller well-tank engine by Neilson, 1850, for the Edinburgh and Glasgow Railway, is shown in Fig. 95. The cylinders, 10in. by 15in., were placed behind the leading wheels, and the driving wheels, 5ft. diameter, were under the footplate. The saloon at the back did not form part of the original engine, but was added with the new boiler about twenty years later.

Sinclair on the Caledonian Railway adopted a modification of the “Crewe” type of engine which had 9in. by 15in. cylinders and 5ft. 1in. driving wheels. It had straight separated plate springs for the leading and trailing wheels, and a single transverse driving spring—see Clark's

"Railway Machinery," plate 24. Brake blocks were applied to the trailing wheels only, as was the case in almost all tank engines of that day. Gooch's stationary link motion was used, with built-up expansion links. The cylinders were horizontal, but in the "Crewe" type tank engines

weight as 14 tons only, of which $7\frac{1}{2}$ tons were carried on the driving wheels, but though no definite statement is made, it seems likely that this was the weight empty. The majority of the engines of this type were built for various railways in Ireland.

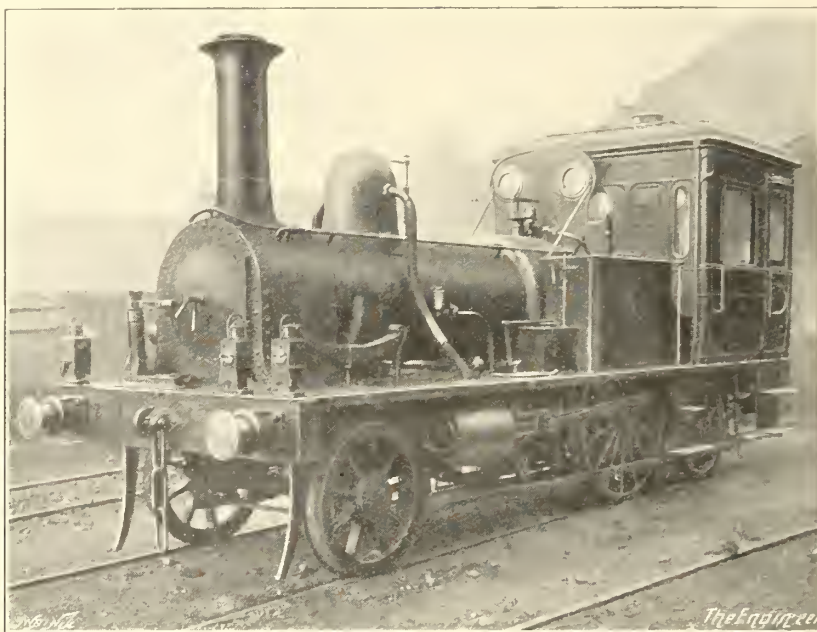

FIG. 95—TANK ENGINE, BY NEILSON & CO., EDINBURGH & GLASGOW RLY., 1859

by Jones and Potts, Kitson, and J. V. Gooch, they were inclined to clear the leading wheels.

J. V. Gooch's celebrated express tank engines of 1851-54—Fig. 96—were used on the Eastern Counties Railway for light main line trains. The driving wheels were 6ft. 6in. diameter, and in the earlier engines the cylinders were 12in. by 22in., increased in the later ones to 14in. by 22in. Heating surface of the latter, 707 $\frac{1}{2}$ square feet; boiler pressure, 110 lb. As in J. V. Gooch's previous L. and S.W.R. engines, the gridiron regulators were placed close to the inlet of the steam pipe into the steam chest. Incidentally, it may be mentioned that these were the first engines built at Stratford Works.

W. Fairbairn and Sons in 1850, followed by the Vulcan Foundry in 1853 and Neilson in later engines, adopted inside cylinders combined with inside framing throughout. Fairbairn's tank engine—Fig. 97—is interesting in that solid welded plate frames were used. These engines, although of extremely small size, worked the lighter passenger trains on the "Little" North-Western Railway—*i.e.*, the line from Skipton to Morecambe, which afterwards was merged into the Midland system. The cylinders were 9 $\frac{1}{2}$ in. by 15in., and the driving wheels 5ft. diameter. D. K. Clark, who mentioned them, gave the

The Vulcan Foundry engines¹ for the Dublin and Wicklow Railway had saddle tanks and Dodds's wedge motion. The driving wheels were 5ft. 3 $\frac{1}{2}$ in. diameter and the cylinders 13in. by 20in. Total heating surface, 776 $\frac{1}{2}$ square feet.

Neilson's engine of this type—Fig. 98—though built in 1862 for the Dublin and Drogheda Railway, may be mentioned here. It was unique in having both side and saddle tanks, and was one of the earliest to have the footplate completely

¹ Illustrated in D. K. Clark and Colburn's "Recent Practice in the Locomotive Engine," 1860, Plate 39.

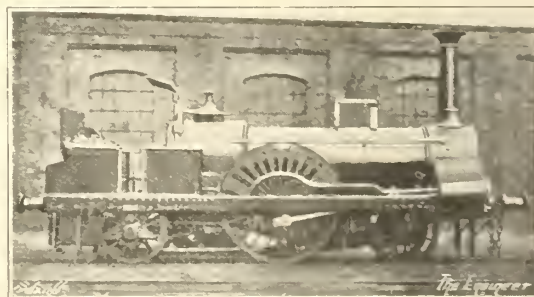

FIG. 96—J. V. GOOCH'S TANK ENGINE, EASTERN COUNTIES RAILWAY, 1854

roofed in. The cylinders were 12in. by 18in., and the driving wheels 5ft. 6in. diameter.

E. B. Wilson's 2-2-2 tank engines were somewhat similar to those of Fairbairn, but the bearings of the carrying wheels were outside, as in the "Jenny Linds." The cylinders were 10in.

North-Western Railway—Fig. 99—of which the boilers, frames and cylinders were made by Messrs. Sharp and the remainder of the work, including erection, was done in 1854-58 at Longsight, Manchester, under John Ramsbottom's supervision, had saddle tanks. J. Ramsbottom

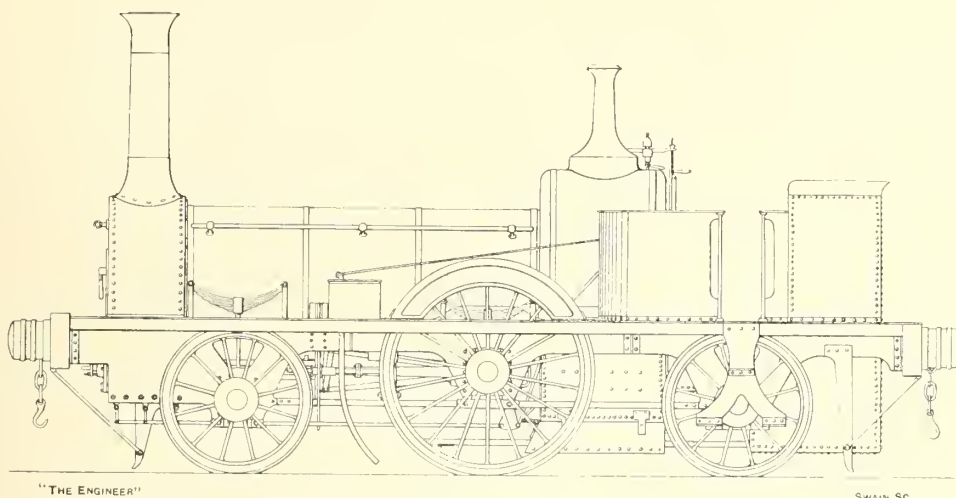

FIG. 97—TANK ENGINE BY W. FAIRBAIRN & SONS, "LITTLE" NORTH-WESTERN RLY., 1850

by 17in., and the driving wheels 5ft. 6in. The weight in working order was 19½ tons. A characteristic of both Wilson's and Fairbairn's early tank engines was the domeless boiler. In place of the dome, the fire-box casing—as in Fig. 97—was raised 1ft. above the barrel to provide a steam space, though the steam was taken from a perforated pipe at the top of the barrel. The raised flat ends of the casing were stayed by means of short longitudinal stays secured to angle irons. This form of raised fire-box casing was used for many years by Manning, Wardle and Co. in tank engines built by them.

George England and Co., of Hatcham Ironworks, London, built a number of extremely neat well-tank engines between 1850 and 1856—see D. K. Clark's "Railway Locomotives," Plate 42. The inside cylinders, 9in. by 12in., were placed behind the leading axle, and the connecting-rod was 3ft. 5in. long. The framing was of the outside sandwich type, with outside bearings only. The driving wheels were only 4ft. 6in. diameter; nevertheless, the engines were reputed to be excellent runners. The total wheel base was 12ft. 8in. D. K. Clark records that their duty was to take seven carriages on a run of 47½ miles with six stoppages, at a speed of 36 miles per hour on a consumption of 9.7 lb. coke per mile.

Sharp, Stewart and Co. discarded the outside cylinder inside-framed type for one with inside cylinders and double sandwich frames. Those built by the firm had the usual well and back tanks, but a large number for the London and

was originally locomotive superintendent of the North-Eastern Division of the London and North-Western Railway, with headquarters at Longsight, until his removal to Crewe in 1857. The above engines were in most other respects similar to the well-known 2-2-2 tender engines by Sharp Brothers, and had 5ft. 6in. wheels and 15in. by 20in. cylinders. Some of them were the first to have Ramsbottom's safety valves. For a considerable period they worked the local traffic from Manchester (London-road) to Stockport, Macclesfield, and Alderley Edge.

After 1858 the single driver tank engine almost died out. A few were built as late as 1866 by Sharp, Stewart and Co. for the Furness Railway, and a number of Sharp's old tender engines were

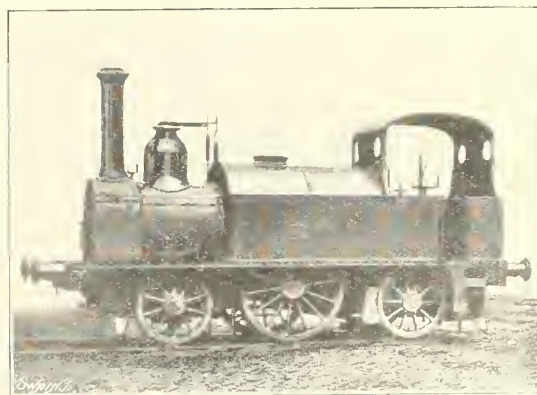

FIG. 98—NEILSON'S TANK ENGINE, DUBLIN & DROGHEDA RAILWAY, 1862

converted to tank engines on the G.N.R. and L. and N.W.R. for light branch line service. In Ireland the type held its own for several years longer, notably on the Dublin, Wicklow and Wexford Railway, for which a considerable

The Great Northern 2-2-2 express engine by R. and W. Hawthorn, 1852—Fig. 100—was a characteristic design of this firm, and embodied a number of improved details. The inside frames of 1in. iron plate extended from the front to the

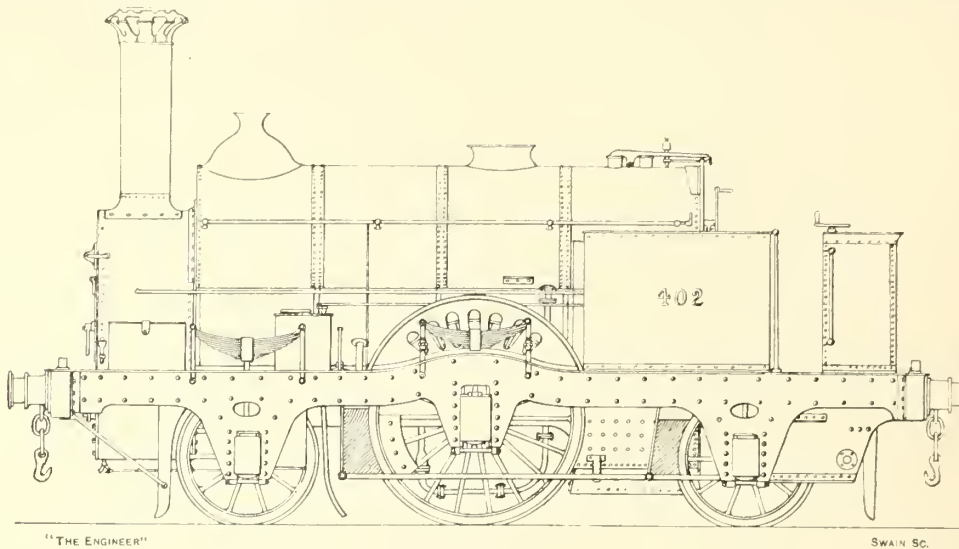

FIG. 99—SADDLE TANK ENGINE, L. & N.W. RLY., 1854-1857

number of the inside-framed type were built between 1865 and 1873.

Express Engines.—From 1850 onwards the types of standard gauge express engine became less experimental than those which were evolved between 1845 and 1849, and the majority were of

back buffer beam, instead of terminating at the front of the fire-box, as had till then been the usual practice. The outside frames were of the sandwich pattern, 5in. wide outside the flitch plates, and both frames on each side were firmly braced together between the wheels. Compen-



FIG. 100—R. & W. HAWTHORN'S ENGINE, GREAT NORTHERN RLY., 1852

the 2-2-2 type, with inside cylinders and double frames. The most notable exceptions were the London and North-Western "Bloomers" of McConnell's design, and the outside cylinder engines of the "Crewe" and London and South-Western types.

sating levers were applied between the leading and driving springs. They were patented by Messrs. Hawthorn in 1851, though, as Colburn pointed out, such "equalising beams" had been used since 1837 in America. But the credit for them must undoubtedly be given to Timothy

Hackworth, who in 1827 provided the "Royal George"—Fig. 3, page 5 *ante*—with levers between the bearings of the leading and middle axles. They were noted by the two Prussian engineers who saw the drawings and recorded that the levers were to allow the wheels to adjust themselves to the unevenness of the road. See "A Century of Locomotive Building," page 126. After their introduction on the Great Northern,

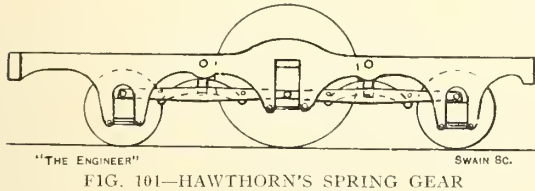

FIG. 101—HAWTHORN'S SPRING GEAR

most of A. Sturrock's locomotives were fitted with them. In the 2-2-2 and 0-6-0 engines they were placed between the leading and driving, and in the 2-4-0 engines between the coupled axles.

But in Hawthorn's first engine of the type at the 1851 Exhibition the spring gear was arranged as in Fig. 101 with one inverted spring between each pair of axles, the load being transferred to the axle-boxes by the compensating beams. The spring-borne mass was supported on four points, as in the modified Great Northern arrangement, but with the disadvantage that these points of suspension were brought too close together, and the distance between them was only about half the wheel base. The pitching oscillations of such an express engine must have been considerable;

have been that by attempting to equalise *as far as possible* the loads on the wheels the tire wear would also be equalised.

The engine shown by Fig. 100 had a dome,

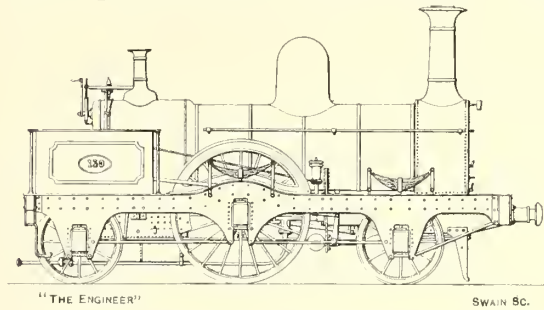

FIG. 102—STEPHENSON ENGINE, MIDLAND RLY., 1852

but, of the twelve built, at least three were domeless and provided with Hawthorn's steam collecting pipe. The general dimensions were those usual for express engines of the period:—Cylinders, 16in. by 22in.; driving wheels, 6ft. 6in.; carrying wheels, 4ft.; wheel base, 7ft. 9in. + 7ft. 3in. = 15ft. All the outside journals were of the double coned form. The boiler, 10ft. long by 4ft. diameter inside the largest (middle) ring, contained 171 2in. tubes, and the fire-box had a transverse partition. Heating surface: tubes, 874.4 square feet; fire-box, 114 square feet; total, 988.4 square feet; grate area, 13.64 square feet; total weight in working order, 27 tons 16 cwt. The boiler pressure has not been recorded, but it may be added that many of A. Sturrock's Great

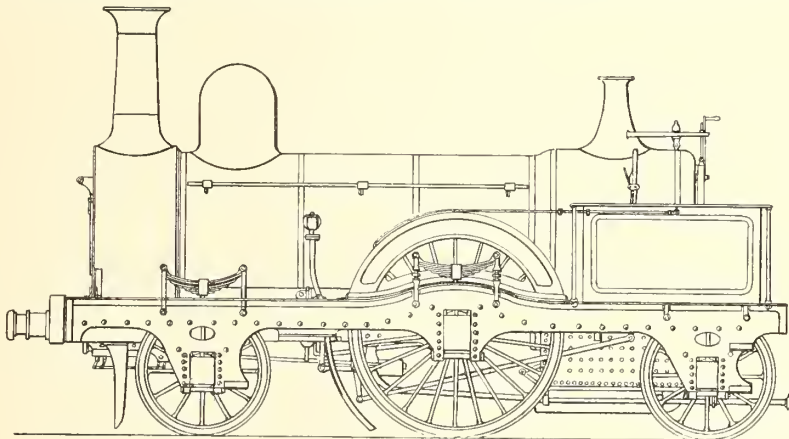

FIG. 103—MIDLAND RLY. EXPRESS ENGINE, 1853-4

nevertheless, Sir Daniel Gooch's first standard-gauge 2-2-2 engines of 1855-56 had two pairs of compensating levers, and he also adopted a similar arrangement on his six wheels coupled broad-gauge tank engines. Such a system was quite unnecessary and had the grave defect that in the case of the breakage of a spring one side of the engine was completely let down. The idea involved, in the 0-6-0 engine at least, appears to

Northern engines worked at 150 lb. The writer quotes the following passage from a letter² by A. Sturrock:—"The success of the G.N.R. was nearly entirely due to the introduction of fire-boxes of about double the area of those in use on the narrow-gauge in 1850, and the raising of the steam pressure from 80 lb. to 150 lb. . . . Engines, like horses, go well in many shapes,

² Original in possession of the writer.

sizes, and colours, but no variations such as position and diameter of a wheel or diameter of cylinder are worth anything unless there be plenty of steam at a *high pressure*, which gives economy by expansion. The finest gun is no use unless there be plenty of powder."

Six express engines by R. Stephenson and Co.,

partitions in the fire-boxes and the heating surface was increased by about 19 square feet. Of the total weight of 29½ tons, 12 tons 7 cwt. were carried on the driving wheels.

McConnell, like Archibald Sturrock, was a believer in higher pressures, and when the "Bloomers" were new they were pressed at 150 lb.

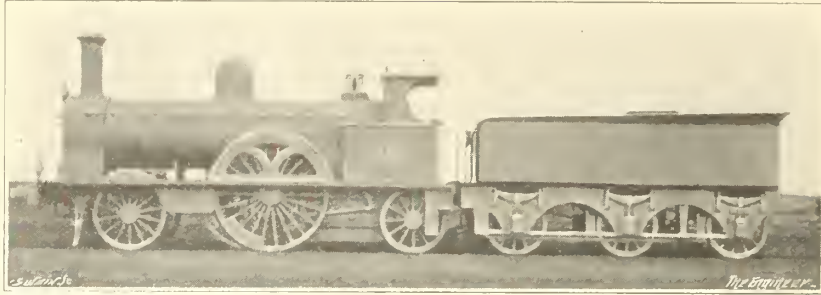

FIG. 104—L. & N.W. RLY. REBUILT 7ft. "BLOOMER," 1851-62

1852, for the Midland Railway—Fig. 102—had 6ft. 8½in. driving wheels and 16in. by 22in. cylinders. The wheel base was 15ft. 6in., equally divided; total heating surface, 1097 square feet; weight in working order, 28 tons, of which 12 tons 3 cwt. were carried by the driving wheels. The inside frames terminated at the front of the fire-box casing.

These engines may be compared with the contemporaneous Midland express engines by Sharp, Stewart and Co., illustrated by Fig. 103. In Stephenson's engines the horn plates were much deeper and were connected together by tie rods of circular section. In Sharp's engines shallow horns without tie rods were used.

Many of these old single engines were capable of very good work with fairly heavy trains. In 1889 the writer saw Midland engine 133, one of the "Stephensons" just mentioned, on a fast train of eighteen six-wheeled coaches, weighing about 215 tons behind the tender, with which it kept time from Trent to Leicester at a booked speed of 44½ miles per hour. In estimating the value of such performances it must not be forgotten that the resistance per ton of the old six-wheeled carriage stock was greater than that of modern bogie stock.

J. E. McConnell's first 2-2-2 express engines of 1851-2 for the southern division of the L. and N.W.R. had inside frames and bearings only. These engines, which were known by the nickname of "Bloomers," had 7ft. driving wheels, 16in. by 22in. cylinders, leading wheels 4ft. 6in., and trailing wheels 4ft. diameter. The wheel base, 16ft. 10in., was exceptionally long. The first ten engines had fire-boxes with transverse partitions. The boilers contained 195 2½in. tubes and had a total heating surface of 1448½ square feet, of which the fire-box provided 146.3 square feet. The second lot of ten engines had longitudinal

per square inch, though at a later date the pressure was reduced to 120 lb. Whether the moderate adhesive weight was responsible for the reduction is not definitely known. But the London and North-Western Company did not generally care to exceed 120 lb. pressure, which remained the standard at Crewe until F. W. Webb raised it to 140 lb. in 1874. McConnell also broke boldly away from the low centre of gravity theory, and in the "Bloomers" the boiler centre was pitched 7ft. 1in. above the rail level.

There were forty of the class, of which Sharp, Stewart and Co. built twenty-five in 1851-61, Kitson and Co. five in 1861, and the remainder were constructed at the Wolverton works in 1861-62. In their original condition they were illustrated in *The Engineer*, August 24th, 1923, page 196, Fig. 4. Until 1880 the greater part of the main line express service between Euston, Rugby, and Birmingham was worked by them, and in their day they were the best express engines on the line. As rebuilt by J. Ramsbottom at Crewe with boilers carrying only 120 lb. pressure, one of them is shown by Fig. 104. In this form they

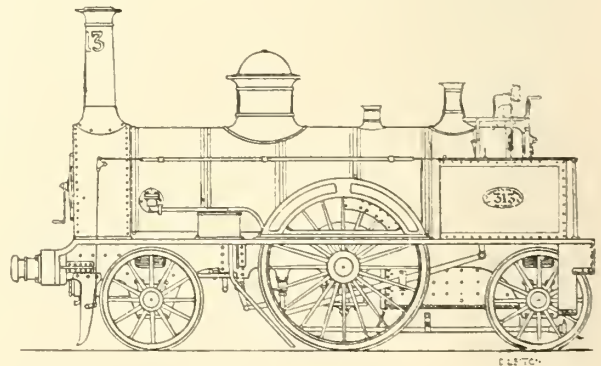

FIG. 105—L. & N.W. RLY., McCONNELL "SMALL BLOOMER," 1854-61

will be remembered by many of our readers.

Between 1853 and 1861 thirty-six somewhat similar engines—Fig. 105—known as the “Small Bloomers,” were built to McConnell’s designs, eleven by the Vulcan Foundry and Hawthorn, and the remainder at Wolverton. They had 6ft. 6in. driving wheels, 16in. by 21in. cylinders. The wheel base was 15ft. 6in. and the total weight in working order 23 tons 13 cwt. They worked the secondary fast trains on the southern division of the L. and N.W.R., but having only 10 tons on the drivers, as originally built, were never equal to the more celebrated class with 7ft. wheels. The illustration shows one of the later 1861 engines with laminated plate springs, but all the “Bloomers” of 1851 to 1854 had india-rubber springs similar to those of the engines described below.

Here it may be pointed out that the position of some of the chief locomotive superintendents at this time was not an easy one. The weight and speed of trains were rapidly increasing.

they would have been able to perform the two-hours’ run is possible had the permanent way been suitable, but the attempt does not appear to have been made.

The cylinders were 18in. by 24in., driving wheels 7ft. 6in., leading wheels 4ft. 6in., and trailing wheels 4ft. diameter. The wheel base, as in the large “Bloomers,” was 8ft. 4in. + 8ft. 6in. = 16ft. 10in. The cylindrical portion of the boiler was 11ft. 9in. long by 4ft. 3½in. outside diameter and of ⅜in. Low Moor plates. The fire-box had a long combustion chamber (McConnell’s patent), which extended into the barrel, the length at the roof, including the chamber, being 10ft. 6in., the length at the grate being 5ft. 10¼in. It was also provided with a longitudinal partition, which extended into the chamber to a line 2ft. behind the tube plate. The brass tubes were only 7ft. long, but 303 of them, 1¾in. outside diameter, were packed into the front barrel. Tube heating surface, 971¾ square feet; fire-box heating surface, including that of combustion chamber, 260 square

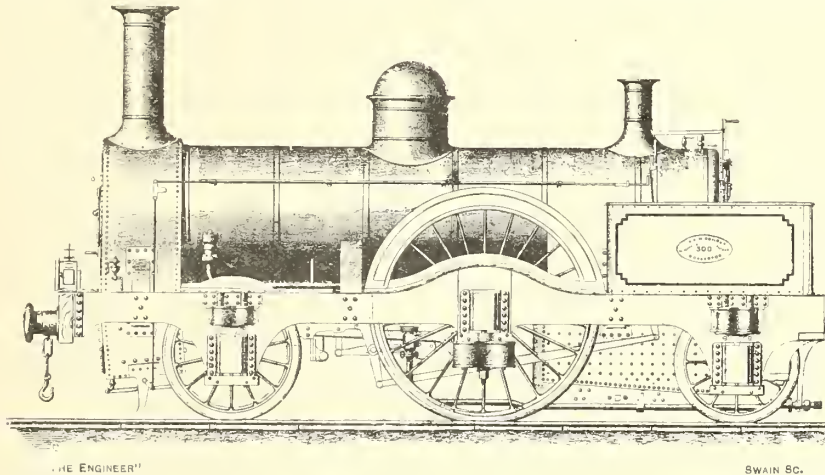

FIG. 106—McCONNELL'S EXPRESS ENGINE, L. & N.W. RLY., 1852-54

Economical engines of considerably greater power had now to be designed to meet these conditions, but they had to run on light and soft iron rails which weighed anything from about 55 lb. to 75 lb. per yard, and the permanent way department was not slow in complaining if the heavier engines rolled out and hammered the rails. The first lot of the large “Bloomers” had not been at work more than a few months when McConnell was called upon to design a much larger class for the purpose of running express trains between London and Birmingham (112½ miles) in two hours, a feat which the L. and N.W.R. directors had in 1852 announced their intention of performing. Twelve of these engines were built in 1852-54 by W. Fairbairn and Sons and E. B. Wilson and Co. Bearing in mind the above conditions, it will be conceded that these new L. and N.W.R. locomotives—Fig. 106—were amongst the most remarkable of their day. That

feet; total, 1231¾ square feet; grate area, 23½ square feet; pressure, 150 lb.; weight in working order: leading, 11 tons 12 cwt. 2 q.; driving, 12 tons 3 cwt. 3 q.; trailing, 7 tons 8 cwt.; total, 31 tons 4 cwt. 1 q.

Although McConnell was an advocate of high-pitched boilers, he apparently did not at that time care to go too far in this direction, and the centre was placed 6ft. 10in. above rail level, though this height was considerably greater than was usual in standard-gauge engines. It is not unlikely that outside influences were brought to bear, but whatever the causes, there are few more striking examples of the effects of the whole design of a too rigid limitation of a single dimension. The boiler and combustion chamber had to be recessed to allow the cranks to work underneath. In contra distinction to McConnell’s usual practice of horizontal cylinders, the latter, spaced at 1ft. 10½in. centres, were placed very low down

and inclined upwards towards the back, the bottom slide bars just clearing the leading axle. To obtain crank webs of sufficient thickness the inside bearings, 7in. diameter, were only $4\frac{1}{4}$ in. long, and this small bearing area reduced the inside frames to the position of auxiliaries, which extended only from the motion plate to the front of the fire-box casing, and consisted of two forgings, somewhat similar to bar frames. The main frames were outside and provided the principal bearings, 7in. diameter by 10in. long, for all three axles. These were the only engines which McConnell ever designed with outside frames and four bearings for the driving axle, but he discarded the hitherto usual sandwich frame as too heavy, and the outside frame with horns was formed of a single welded iron plate.

A weak point in the design was the attachment of the cylinders, which were bolted to the smoke-box, the latter being of stout plate and extended downwards. Why the inside frames were not brought to the front buffer beam is not clear, but in their absence the smoke-box and cylinder flanges had to be secured to the outside frames by means of a complicated bracket

a half times the finished diameter. The pieces when clipped together were partially welded at each end, and the complete welding of the whole length was done in a special rolling mill. Each axle was then swaged under the steam hammer, during which operation a jet of water played upon it, and enabled any unsoundness in the weld to be detected. It was finally cut to length by a circular saw and the end journals swaged down to the proper diameter. McConnell appears to have used these hollow axles before 1845 on the Birmingham and Gloucester Railway.³

The piston heads, forged solid with the rods, and the cylinder and steam chest covers were of wrought iron. It is possible that considerations of weight also affected the boiler, of which the plates were only $\frac{3}{8}$ in. thick, the usual dimension at that time for boilers about 3ft. 9in. to 4ft. diameter carrying only 110 lb. to 120 lb. pressure. McConnell's engine was pressed at 150 lb. and had a boiler 4ft. $3\frac{1}{4}$ in. diameter. Many engineers were then using $\frac{7}{16}$ in. plates, and Hawthorn's Great Northern engines with 4ft. barrels had $\frac{1}{2}$ in. plates.

The long combustion chamber, which reduced

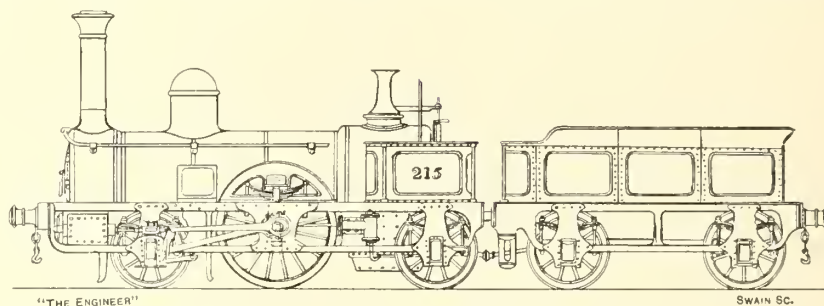

FIG. 107—VULCAN FOUNDRY LOCOMOTIVE, SHREWSBURY & HEREFORD RLY., 1853

forging. The arrangement of outside framing and cylinder attachment was so completely at variance with McConnell's prior and subsequent practice, in which simple inside plate frames were always the feature, that one can only conceive that he was forced to this design by some definite instruction in regard to the height of his boiler. The previous "Bloomers" with 7ft. wheels had their boiler centre $2\frac{1}{2}$ in. higher than the new engines with 7ft. 6in. wheels. Colburn, who referred to these engines—"Locomotive Engineering," p. 72—confused some of his dimensions and particulars with those belonging to a later class of 1861, in which the boiler centre line was raised to 7ft. $5\frac{1}{2}$ in. above rails and the simple inside-framed design restored.

In order to keep the total weight down the carrying axles were hollow, $7\frac{1}{4}$ in. outside and $4\frac{1}{4}$ in. inside diameter, leaving the metal $1\frac{1}{2}$ in. thick. They were manufactured by the Patent Shaft and Axletree Company, of Wednesbury, from a set of bars in form of sectors rolled with overlapping angles so that, when placed together for welding, they formed a complete cylinder about one and

the length of the tubes to 7ft. only, would in itself save some weight, though much of this gain was offset by the increased number of roof girder stays, arranged transversely. Of the combustion chamber and its effect mention will be made subsequently. The only point to be noted now is that these engines were specially designed for coal burning. In the smoke-box was fitted a form of superheater or steam dryer, consisting of a flat chamber or box placed a short distance in front of the tube plate. The box was traversed by short tubes registering with the boiler tubes and arranged so that the gases from the latter passed through them. The steam on its way to the cylinders passed through the body of the box surrounding the tubes.

The springs consisted of three india-rubber discs separated by $\frac{1}{2}$ in. plates and covered by casings. Two of these were placed side by side. This form of spring (Coleman's) was used by McConnell for a number of years, and was not special in the case of these engines.

The Shrewsbury and Hereford Railway, opened

³ Gauge Commission Report, Question 557.

in 1853, was supplied by the Vulcan Foundry with six 2-2-2 passenger engines—Fig. 107—of peculiar design. The steam chests and valve gear were outside, as in Stephenson's express engine mentioned previously, but differed from Stephenson's, in that the eccentrics were placed outside the outside frame. The framing itself with the peculiarly shaped axle guards bolted on looks weak, but the engines were not of large size. They had 15in. by 20in. cylinders and 5ft. 6in. driving wheels.

A. Sturrock's large bogie express engine built by Hawthorn in 1853, with 7ft. 6in. single driving wheels and 17in. by 24in. cylinders, may fitly be compared with the large McConnell engines just described. It is shown by Fig. 108, and it will be sufficient to mention that both the bogie and main framing were of the outside sandwich type. The bogie wheels were 4ft. 3in. diameter, bogie wheel base 7ft. 2in., and total wheel base 21ft. 8½in.; total heating surface, 1719.2 square feet, of which the fire-box with partition supplied 155.2 square feet; total weight in working order, 37 tons

merits mention. In the Crewe boilers the steam was usually taken from a pipe at the top of a dome, situated above the fire-box, and the regulator was placed immediately over the latter at the junction of the dome pipe and the main steam pipe to the smoke-box. A small steam chamber on the centre of the barrel slightly increased the steam space. To avoid taking all the steam from a point immediately above the fire-box, the new engines had two steam chambers, from both of which steam was taken to the regulator over the fire-box. This was a revival of the former practice of two domes, but with the disadvantage that instead of having a short T pipe from the front dome to the main steam pipe, as in Gray's engines, an additional long pipe conveyed the steam from the front chamber back to the fire-box end, whence the main pipe returned it to the smoke-box. There was an unnecessary filling of an already small steam space with two pipes; moreover, the openings into the pipes were not sufficiently high above the water level in the boiler.

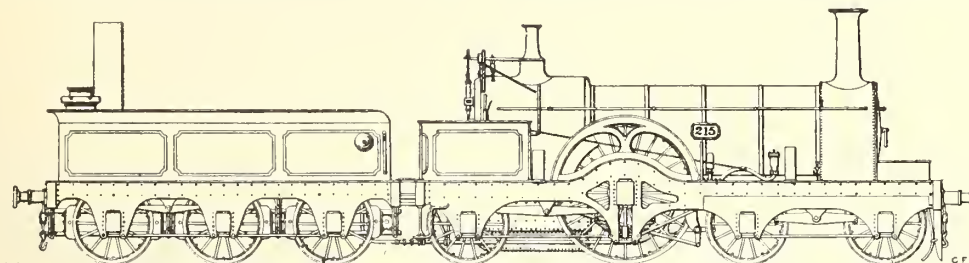

FIG. 108—A. STURROCK'S BOGIE EXPRESS ENGINE, GREAT NORTHERN RLY., 1853

9½ cwt. Only one engine of the class was built, for the reason that in size and weight it exceeded the requirements of that day. The bogie wheels and the driving and trailing wheels formed two groups, each connected by compensating levers on the three-point suspension system.

The outside cylinder express engine made very little progress between 1850 and 1855. On the L. and S.W. Railway the diameter of the driving wheels was increased in 1850 from 6ft. 6in. to 7ft. in a number of engines built by the company at Nine Elms. In other respects these engines were similar to J. V. Gooch's previous design. In subsequent engines after 1853 the diameter of driving wheels reverted to 6ft. 6in.

Whilst McConnell was building his large engines for the southern division of the L. and N.W.R., Francis Trevithick and Alex. Allan went to the opposite extreme in those built at Crewe for the northern division of the same railway. The 1846-47 types with 15in. by 20in. cylinders remained standard, and 6ft. wheels were considered large enough for express passenger traffic. But in 1854-57 F. Trevithick built fifteen engines with 7ft. wheels, on similar lines to the "Velocipede" of 1847, except that the large eccentrics outside the driving wheels of the latter gave place to the standard inside direct valve motion.⁴ One detail

Four-wheels Coupled Passenger Engines.—By 1852 the type of coupled passenger engine had settled down on most of the leading main lines to the 2-4-0 pattern, with inside cylinders and double frames. Many of these engines were built by R. and W. Hawthorn and E. B. Wilson, though a few came from Stephenson's and Fairbairn's works, and in 1854 Sharp, Stewart and Co. also adopted this design. For some years the type with inside cylinders and single frames, as evolved by Stephenson in 1842, was almost entirely abandoned. In spite of the greater tendency of the double-framed engine to break crank axles, the opinion of the locomotive engineers was that with stronger outside frames this liability decreased, and in case of a broken axle the wheel was supported by the two bearings on each side. The inside driving bearings could be made shorter, long outside bearings gave a larger bearing area than was otherwise possible, and the crank webs could be made of greater width. Generally, the coupled wheels were 6ft. in diameter, though a number had 5ft. 9in. and 5ft. 6in. wheels. The cylinders were usually 16in. by 20in. and 16in. by 22in., with the steam chest between. E. B. Wilson's engines were described

⁴ Drawings of one of these engines are given in "The Life of Richard Trevithick," by F. Trevithick.

and illustrated in *The Engineer* of October 15th, 1920, pages 370-1.

Hawthorn's engines of 1851 were built for the Great Northern Railway to A. Sturrock's general instructions, and had 6ft. driving wheels and 16in. by 22in. cylinders. The boiler was of Hawthorn's domeless type, and in accordance with Sturrock's practice carried 150 lb. pressure.

with 5ft. 6in. wheels, 15in. by 20in. cylinders, and short wheel base 5ft. 6in. + 5ft. 11in. = 11ft. 5in. They were stated to have been modelled on W. and A. Kitching's Stockton and Darlington engines—Fig. 60 *ante*—and were intended principally for the London and Hastings road, on which the curves are severe. Their chief characteristic was the form of compensating lever

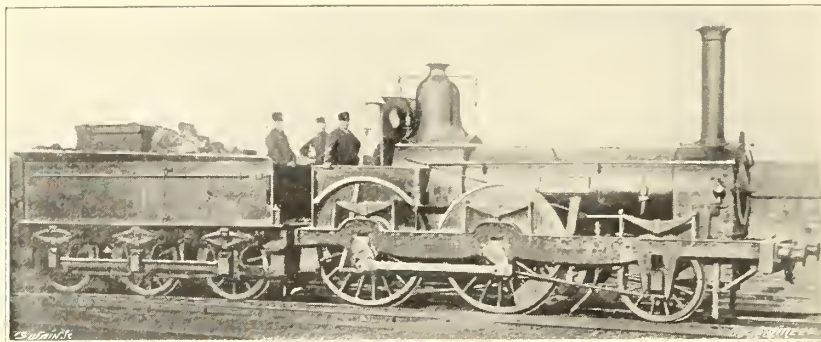

FIG. 109—JOSEPH BEATTIE, L. & S.W. RLY., 1851-55

The total heating surface was 1006 square feet, of which the fire-box supplied 102 square feet. Some very similar coupled express engines of 1855 will be illustrated later.

The London and South-Western 2-4-0 engine—Fig. 109—is interesting in that it was the first type (1851-55) designed and built at Nine Elms by Joseph Beattie, and, unlike all his succeeding passenger engines, had inside cylinders. It is illustrated chiefly on account of the peculiar shape of the outside sandwich frames, which were of a

with single spring between the coupled wheels, a spring gear which Cudworth subsequently used for tank engines. The six-wheeled tenders also had the springs of the front pairs of wheels connected by compensating levers. The boiler barrel was 13ft. 6in. long, and provided $935\frac{1}{2}$ square feet of heating surface, to which the short fire-box added $63\frac{1}{2}$ square feet, total 1099 square feet. Of the total weight in working order of 26 tons the leading wheels carried only 6 tons 4 cwt.

A number of similar engines were built at

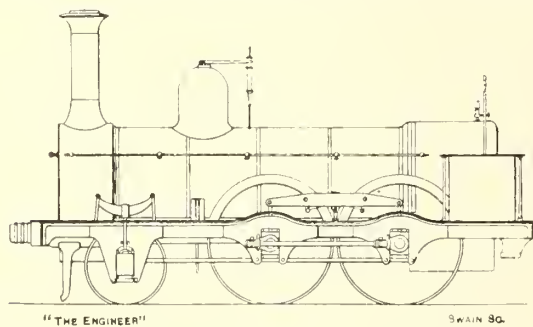

FIG. 110—SOUTH EASTERN RLY., CUDWORTH, 1853.

girder form deepened in the centre between the axles. This design was the exact opposite of the usual arch form, and shows considerable weakness near the horns where frames generally break. The inside frames were of the bar type. These engines had 15in. by 22in. cylinders, and 5ft. 6in. coupled wheels, and were also peculiar in that the leading wheels had a diameter of only 3ft.

J. I. Cudworth's first 2-4-0 engines built 1853-55, at the Ashford Works of the S.E.R., shown in the diagram—Fig. 110—deserve notice. They were of the double-framed long-boiler type,

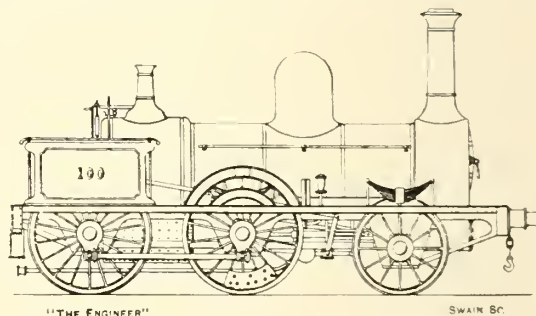

FIG. 111—CHESTER & BIRKENHEAD RLY., R. STEPHENSON, 1853

Brighton works by J. C. Craven, who in several of his designs took Cudworth as a model.

One interesting exception to the double-framed 2-4-0 engines was a type with inside frames throughout—Fig. 111—which was built in 1853 by R. Stephenson and Co., for the Chester and Birkenhead Railway. Unlike certain other firms, such as Sharp Brothers, Messrs. Stephenson did not hold to any particular type or design, and therefore in the locomotives built by this firm we find widely differing examples. Hitherto their inside-framed 2-4-0 engines had been of the

"long boiler" type, both with outside and inside cylinders, but in the Birkenhead engines the trailing wheels were placed behind the fire-box. Another change was the substitution of an ordinary raised fire-box casing for one of the vaulted Gothic type, with which several similar engines built the same year for Egypt were fitted. The type is interesting in that it was the forerunner of many similar engines of later years on

feeding the boiler when standing was fixed, as shown, at the side of the fire-box. These engines had 15in. (later 16in.) by 24in. cylinders, 3ft. 6in. leading and 5ft. coupled wheels. The total wheel base was 14ft. 6in. and the 8ft. coupling rod was long for that period. The fire-box had 113.8 square feet of heating surface, the total being 1167.8 square feet; grate area 15.64 square feet; pressure, 130 lb. Beattie used very small tubes in

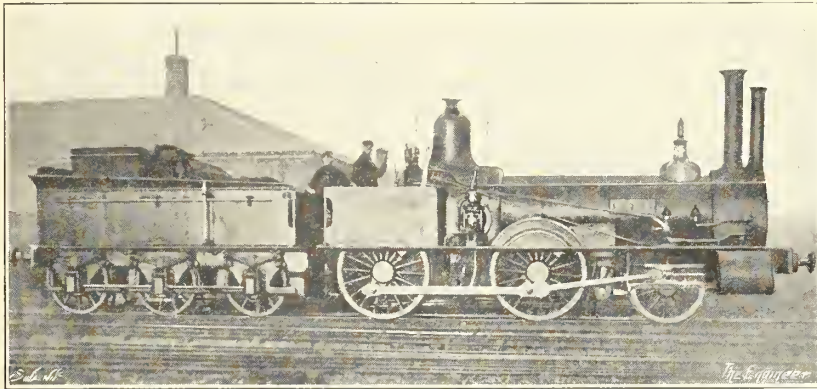

FIG. 112—L. & S.W. RLY. GOODS ENGINE, JOSEPH BEATTIE, 1855

various railways. The cylinders were 14½in. by 20in., coupled wheels 5ft. 6in. diameter, and the total heating surface 780 square feet. The unusually large size, 4ft. 3in., of the leading wheels may be noted. It is uncertain whether the balance weights shown were in the wheels when the engine was new.

The only 2-4-0 engines with outside cylinders which need be mentioned were introduced on the

his boilers, those in the engines described having an external diameter 1⅜in. only. The fire-boxes were Beattie's patent for coal burning, and the engines were the earliest coal burners on the L. and S.W.R. Of the total weight of 29 tons 4 cwt., 11 tons 7 cwt. rested on the driving and only 8 tons ½ cwt. on the trailing wheels.

The eighteen engines designed for the Eastern Counties Railway by J. V. Gooch and built

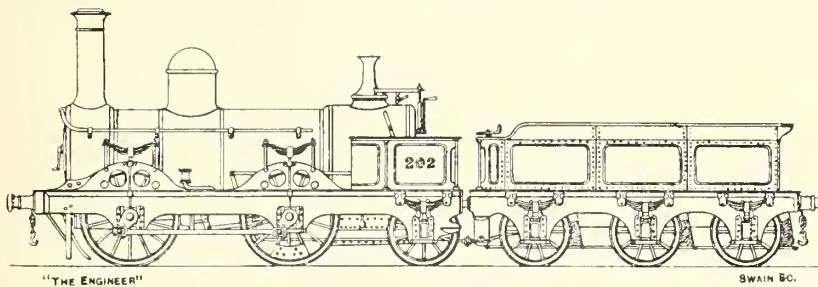

FIG. 113—SHREWSBURY & CHESTER RLY., VULCAN FOUNDRY ENGINE, 1853

London and South-Western and Great Eastern railways in 1855, and differed from the prevailing "Crewe" type in that the cylinders were horizontal and secured to the inside frames only, the frames with outside bearings at the leading end being dispensed with. Fig. 112 shows the L. and S.W.R. engines designed and built at Nine Elms by Joseph Beattie for fast goods traffic. The small chimney in front of the chimney proper was a condenser in connection with Beattie's first feed-water heating apparatus,⁵ and a donkey pump for

⁵ *The Engineer*, March 16th, 1923.

1855-56 by Sharp, Stewart, Kitson and the Canada Works (Birkenhead), were generally similar, but had 5ft. 6in. coupled wheels and domeless boilers. The "long boiler" type was discarded, and the trailing wheels, as in Beattie's engines, placed behind the fire-box. Gooch's engines were coke burners.

Mixed Traffic 0-4-2 Engines.—This, the oldest type of six-wheeled goods engine, introduced in 1833 by R. Stephenson and Co., still continued as a handy locomotive for all work. The engines—Fig. 113—built by the Vulcan Foundry in

1853-54 for the Shrewsbury and Chester and Shrewsbury and Hereford railways, present some details of interest. Both outside and inside frames were welded solid from end to end, and a great improvement was made in that the inside frames, instead of stopping short at the front of the

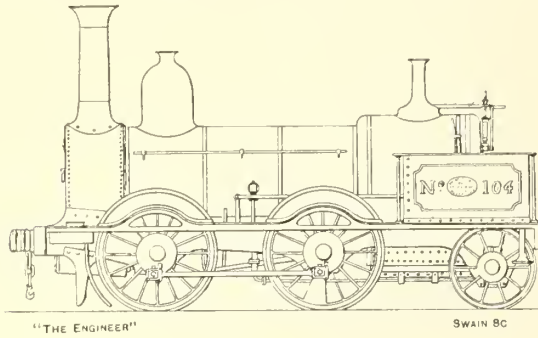

FIG. 114—SHARP BROTHERS' ENGINE, 1848-1854

fire-box casing, also extended from the front to the back buffer beams. The steam chest was Λ -shaped and placed below the centre line of the cylinders. The wheels had balance weights when new. The cast iron horn-blocks were outside the frames, the extra long spring pillars being placed outside the splashes. The latter were of cast iron, of a somewhat heavy and clumsy pattern. The valve spindles were horizontal, with their centres on a level with the centre of the leading axle, to clear which a square frame was inserted in the spindle to embrace the axle. The cylinders were 16in. by 24in., coupled wheels 5ft. diameter, and trailing wheels 3ft. 6in. diameter. A larger boiler than was then usual was provided, which contained 185 $2\frac{1}{16}$ in. tubes, and supplied a total

forty years, chiefly for railways in Wales and Ireland, though a fair number were to be found in other parts of the United Kingdom. The design shows the hand of Charles Beyer, who, until 1854, was responsible for most of Sharp's engines. The cylinders, 16in. by 22in., were inclined, with the steam chest between them, and the motion was both direct and accessible. The coupled wheels were 5ft., and the trailing wheels 3ft. 6in. diameter. The naves of the wheels of these early engines were of cast iron, though in later examples solid wrought iron wheel centres were used. The boiler, 3ft. 8in. diameter, contained 145 2in. tubes, and the total heating surface was 866 square feet.

Six-wheels Coupled Goods Engines.—As in the case of the four-coupled passenger engines, double frames and outside cranks were now generally adopted for main line goods engines, except by McConnell on the London and North-Western Railway. For mineral traffic at slower speeds the inside framed long boiler engine held its own, more especially on the North-Eastern, Stockton and Darlington, and London and North-Western Railways.

Of the types of double-framed engine, the majority had sandwich frames, such as those by Stephenson, Hawthorn, and Wilson on the Great Northern, North-Eastern and other lines. On the two railways mentioned—except in the case of about twenty engines completely reconstructed between 1870 and 1880 by P. Stirling on the G.N.R.—(outside) plate frames were never used, but on the Midland, which was until 1874 emphatically in favour of double-framed engines, sandwich frames for goods engines were discarded by Matthew Kirtley in 1852 in favour of outside plain plate frames. A typical sandwich-

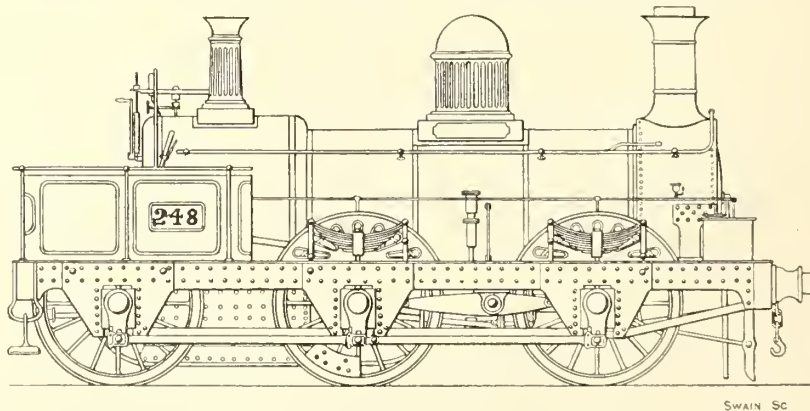

FIG. 115—GOODS ENGINE, OXFORD, WORCESTER & WOLVERHAMPTON RLY., BY E. B. WILSON & CO., 1854

heating surface of 1211 square feet, towards which the fire-box contributed 85 square feet.

In contrast to the above, Sharp's standard mixed traffic engine of 1848 to 1854—Fig. 114—is illustrated. This was a simple straightforward design, which, with variations in a few details and dimensions, was built for a period of nearly

framed goods engine by E. B. Wilson and Co. is illustrated by Fig. 115.

The usual size of cylinders was at this period 16in. by 24in., but a limited number of 17in. and 18in. by 24in. engines were built in 1852-54. For some reason, these larger cylinders did not find favour, and those 17in. diameter were subse-

quently lined up to 16in., whilst the 18in. cylinders were reduced to 17in. diameter. These were hardly cases of "over-cylindering" with small boilers, since the latter for the 17in. engines had up to 1180 square feet of heating surface, of which 112 square feet were in fire-box surface, and were amply large for the duty. Rather does it appear to have been coke consumption that decided the alteration, and in some cases

of the former were 4ft. 3in. mean diameter, 4ft. 4in. diameter outside the largest ring. The barrel was 11ft. 6in. long, and the fire-box casing was flush. Total heating surface of the Stephenson engines was 1184 $\frac{3}{4}$ square feet, of which the fire-box provided 106.6 square feet, that of the Kitson engines being 112 square feet. Owing to the use of a transverse partition in the fire-box, the grate area was reduced to 13.4 square feet.

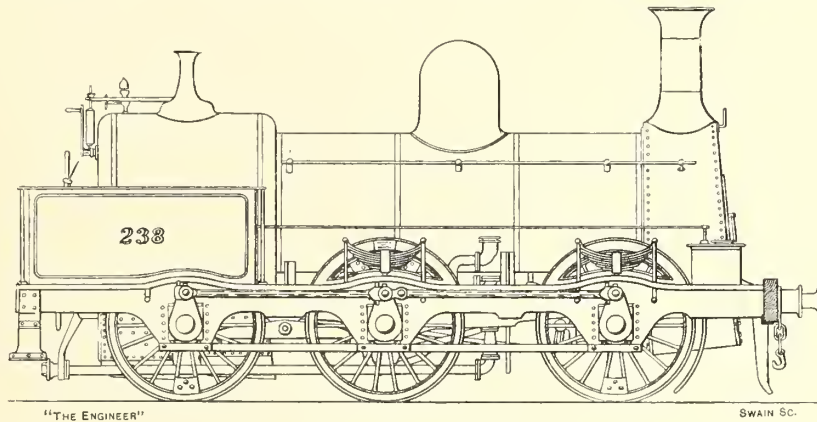

FIG. 116—SHARP'S GOODS ENGINE, M.S. & L. RLY., 1852-54

also the arrangement of the valve gear. The diameter of coupled wheels of most engines was 5ft. to 5ft. 3in.

It was still very unusual to weld the outside frames, and in an engine for the Midland Railway built by Kitson and Co., 1852, the horns were formed of two $\frac{1}{2}$ in. plates bolted on to each side of the main 1in. plate, which was in four lengths. The horn plates were connected by rectangular tie bars, bolted on to form a tension member of the structure. The inside frame extended from the front buffer beam to the front of the fire-box casing only, and was therefore defective in that the drawbar pull was taken from a strong angle iron riveted to the back of the casing, so that the fire-box was called upon to transmit the pull between driving axle and drawbar. E. B. Wilson's design was inferior to Kirtley's, in that the inside frame was not connected to the front buffer beam, but stopped short at the front of the cylinders, which were attached to it in the usual manner. It was this form of double frame, with a short inside frame extending between cylinders and fire-box casing only, which threw the driving bearings out of alignment and caused the breakage of crank axles. When D. K. Clark pointed out the defects of double-framed engines, this was the usual design, and that in which *both* inside and outside frames extended the full length of the engine from front to back buffer beams had appeared only shortly before in 1851 and only in Hawthorn's 2-2-2 engines.

The Midland engines of 1852 by Stephenson (260 class) and Kitson (270 class) had 17in. by 24in. cylinders and large boilers, which in the case

Coke was the fuel used. The smoke-box was of the drumhead type flush with the barrel, but in the engines built in 1853 and subsequently (280 class), the drumhead type was discarded, and the raised smoke-box with angle ring attachment was substituted. A characteristic of the Midland goods engines was the long wheel base. In 1850-52 it was 16ft., equally divided, increased to 16ft. 3in. in the 1853-57 engines, and to 16ft. 6in. in those built from 1858 onwards.

The 0-6-0 goods engines—Fig. 116—built in 1852-54 by Stephenson and Sharp, Stewart for the Manchester, Sheffield and Lincolnshire Railway, to R. Peacock's general instructions, were amongst the most powerful in the country. The outside plate frames were welded solid, and ante-dated McConnell's express engine with similar frames

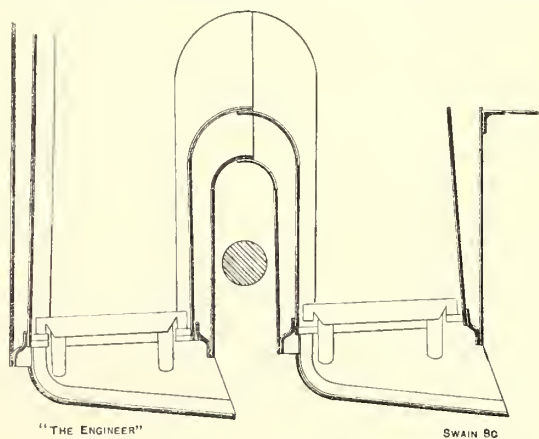

FIG. 117—FIRE-BOX, M.S. & L. RLY.

by a few months. The cylinders, 18in. by 24in., placed at 2ft. 3in. centres, were inclined downwards with the slide valves placed at a Λ angle underneath. The coupled wheels were 5ft. diameter and the wheel base 14ft. only, the trailing axle being brought forward to the middle of the fire-box, through which it passed, by means of a bridge—as shown by Fig. 117—formed in the casing and box, which divided the grate into front and back portions. This bridge was an endless source of trouble, owing to leakages.

The boiler was 4ft. 4in. diameter, and that of the Sharp, Stewart engines contained 229 2in. tubes, of which the heating surface was 1427 square feet, to which the fire-box added 145½ square feet; total, 1572½ square feet; pressure, 120 lb.; weight in working order, 33½ tons. Both connecting and coupling rods were of circular section. After running for a number of years,

without exception, had inside frames, and twelve goods engines built by the company in 1854-55 for the Oldham gradients had 18in. by 24in. cylinders. The experience with these engines was similar to that of other railways, and nearly all of them subsequently had the cylinders reduced to 17in. diameter. Their weight was 33 tons 13 cwt.

In contrast with the majority of the main line goods engines, which had double frames, the 0-6-0 mineral traffic engines were of Stephenson's long boiler type, with inside frames only. These were to be found on most of the principal railways, but chiefly on the Stockton and Darlington, North-Eastern and London and North-Western (Southern Division). Those on the last-mentioned railway were of large size, with 18in. by 24in. cylinders and 5ft. wheels, having been copied by McConnell from Sharp's "Sphinx" class of the

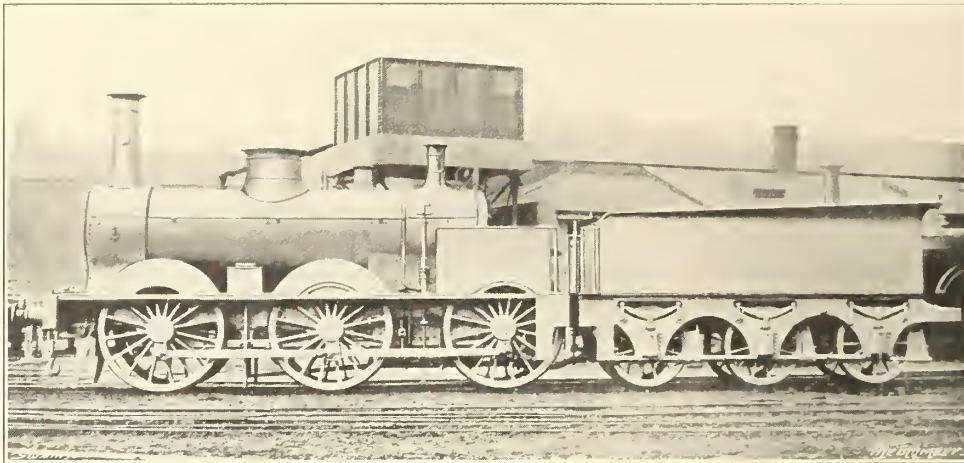

FIG. 118—L. & N.W. RLY., MCCONNELL'S GOODS ENGINE, 1854-63

many of these engines had the diameter of the cylinders reduced to 17in.

McConnell's main line fast goods engines on the southern division of the L. and N.W.R. were examples of more modern practice, and were remarkable in that large six-coupled wheels, 5ft. 6in. diameter, were employed. The first eleven engines were built in 1854 by Kitson and Co., and between 1856 and 1863 ninety-five more were built at Wolverton. The latter, one of which is shown by Fig. 118, differed from those built in 1854 in a few minor details only, such as the position of the sand boxes and the addition of injectors.

The cylinders were 16in. by 24in.; wheel base, 15ft.; the boiler barrel, 10ft. long by 4ft. 4in. diameter, contained 234 1¾in. tubes; and the total heating surface, towards which the fire-box contributed 109 square feet, was 1309 square feet; grate area, 16.3 square feet; the total weight in working order was only 26 tons 12½ cwt.

The Lancashire and Yorkshire Railway engines,

M.S. and L. Railway. A number of engines by Fairbairn, 1852-54, had boilers containing 200 2½in. tubes, 14ft. 4in. long, and fire-boxes with transverse partitions, the total heating surface being 1714 square feet. Two others by the same makers, had 247 2½in. tubes and larger fire-boxes, with a longitudinal partition, and gave a total heating surface of no less than 2082 square feet, though the grate area was only 16.32 square feet. Three others were provided by McConnell with a long fire-box with three longitudinal partitions,⁶ and the patented combustion chamber. Into these boilers 305 short tubes were packed. The tube heating surface was 978 square feet, and that of the fire-box and combustion chamber 339 square feet; total, 1317 square feet. The engines weighed from 30 to 33½ tons in working order, according to the size of the boilers. All boilers with a single longitudinal partition had two fire-holes. The

⁶ This statement is from the old official records, but the writer has not seen any drawing or further description of this unique fire-box.

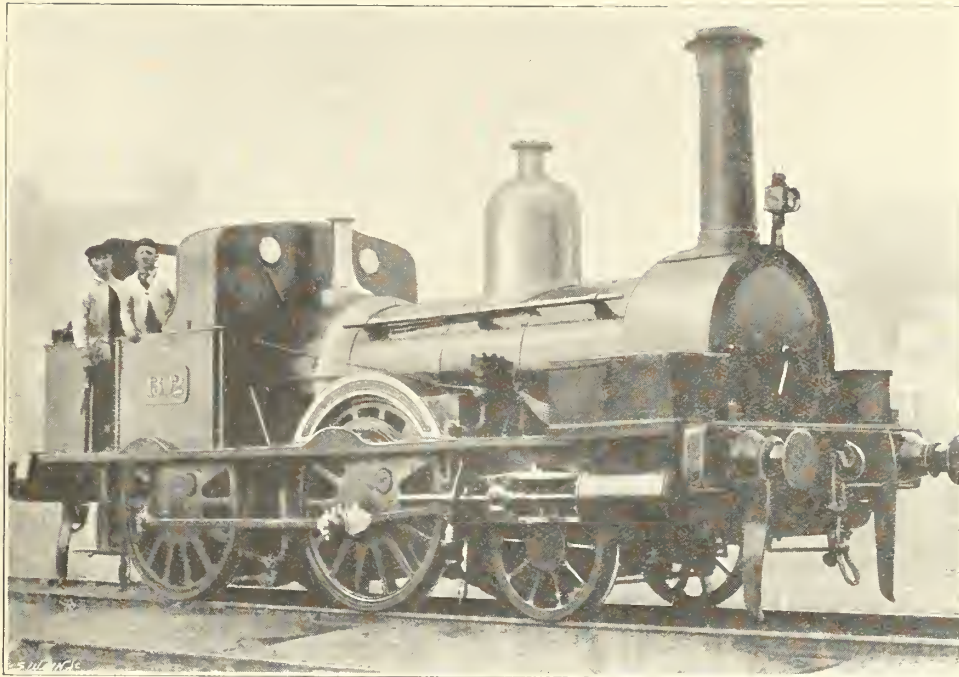

FIG. 119—SHARP BROTHERS' TANK ENGINE, MONMOUTHSHIRE RLY., 1849

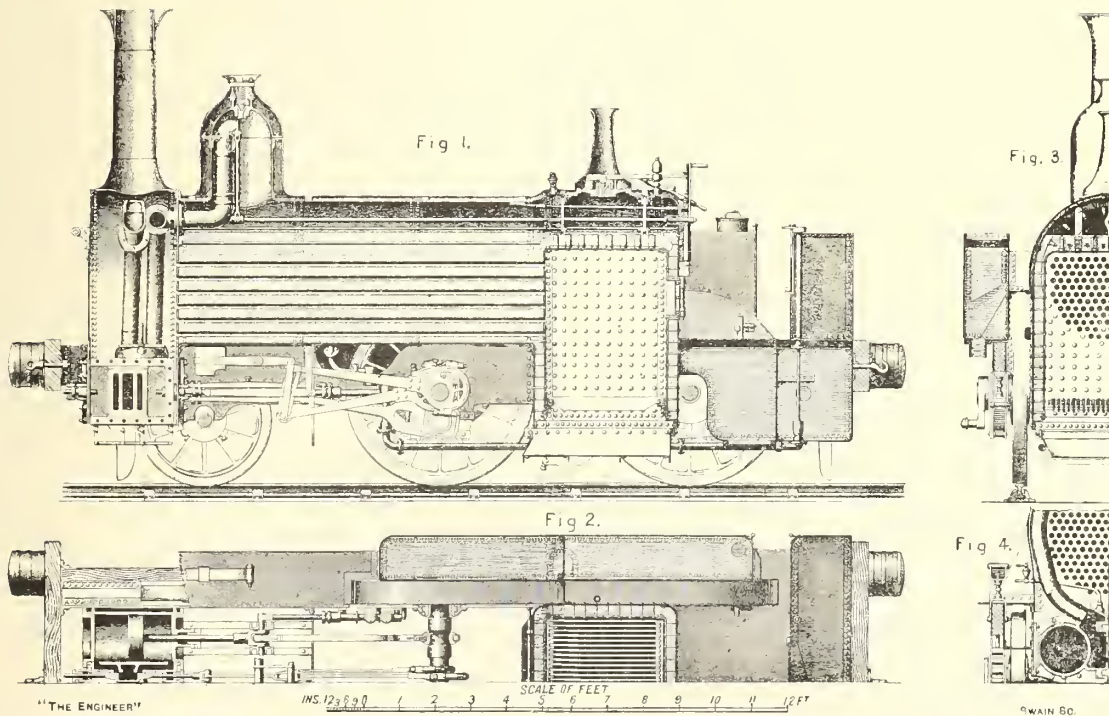

FIG. 120—SHARP, STEWART & CO.'S SIDE TANK ENGINE, SOUTH STAFFORDSHIRE RLY., 1852

earlier engines had raised fire-box casings, but from 1854 onwards most of McConnell's engines were built with flush casings. These McConnell goods engines were almost the only engines in which the 18in. cylinders were not subsequently reduced in diameter.

On other lines, except the Manchester, Sheffield and Lincolnshire, the 0-6-0 long boiler engines, with inside frames, were of considerably smaller size. The North-Eastern, on which similar engines were built until 1870, generally retained Stephenson's original dimensions of 15in. by 24in. cylinders, and wheels varying from 4ft. 6in. to 4ft. 9in. diameter, though there were a few built by R. Stephenson and Co., 1853-55, with 5ft. wheels and 16in. by 24in. cylinders.

By 1849 the Stockton and Darlington Railway had discarded the construction of the Hackworth types and their derivatives, and had also settled down to the Stephenson inside cylinder long boiler

goods engines. The cab shown was a later addition by the Great Western Railway, after the latter had taken over the Monmouthshire Railway.

Messrs. Hawthorn's 2-4-0 well tank of the same period was designed on lines similar to those of their express engine "Plews" of 1848. The outside sandwich frames were of the "arch" form, and the inside frames consisted of two longitudinals placed between the inside cranks and extending from the back of the cylinders to the fire-box casing. The inside cranks were of the Dunham half-crank form, with part of the outside web sunk into the nave of the adjoining wheel. The steam chests were vertical and were placed outside the cylinders immediately behind the outside frames, so that the eccentrics were inside the latter and outside the wheels. The exhaust was taken round the lower portion of the cylinders into a central blast pipe, which was parallel throughout its length. The trailing wheels had

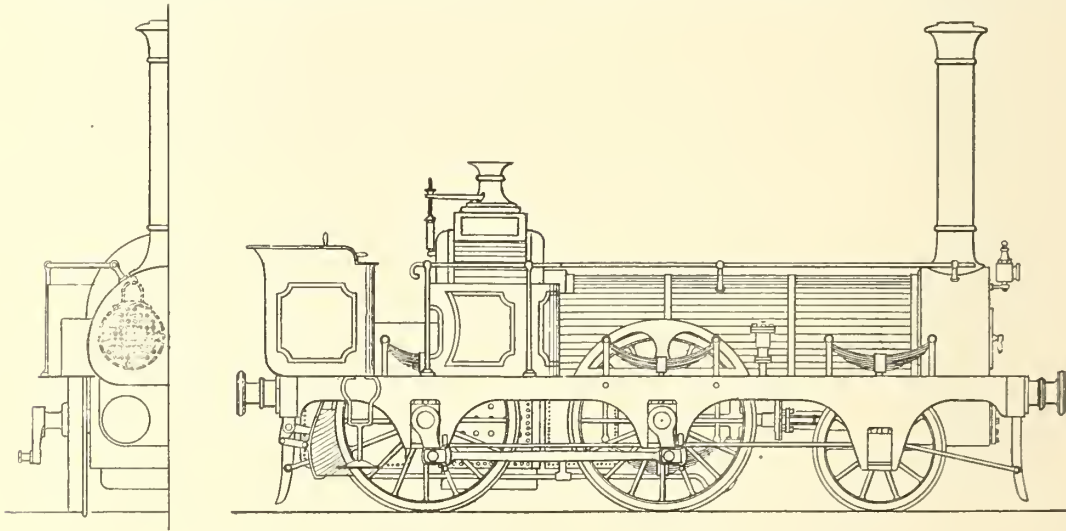

FIG. 121—E. B. WILSON'S TANK ENGINE WITH DOUBLE BOILER, 1851

engines, the majority of which during the 1852-55 period had 4ft. 2½in. wheels and 17in. by 18in. cylinders.

On all lines conveying coal traffic the short wheel base of the long boiler engine was found to be very convenient when shunting into colliery sidings. The Midland employed a considerable number of the Stephenson type engines for the coal traffic between Leeds and Derby, though none were built after 1852 for that line.

Tank Engines with Coupled Wheels.—Of these, there were as yet comparatively few, either for passenger or shunting service. For passenger traffic Sharp Brothers in 1849 built two 2-4-0 well tank engines for the Monmouthshire Railway—Fig. 119—which, if not actually the first, were certainly amongst the earliest four-wheels coupled tank engines. They were of small size, with 5ft. wheels and 13in. by 18in. cylinders. The wheel centres were of cast iron, with balance weights, and similar in design to those of Sharp's heavy

to be placed somewhat far back to clear the footplate and take the weight of the tanks and bunker. These engines were of small size, with 12½in. by 18in. cylinders and 5ft. 6in. coupled wheels. The latter were 7ft. 8½in. apart between centres, and the total wheel base was 13ft. 4in.

Sharp, Stewart's 2-4-0 side tank engine of 1852—Fig. 120—two of which were built for the South Staffordshire Railway, may fairly be described as the first of a more modern era. Unlike the early eight-wheeled side tank engines—Fig. 86 *ante*—the tanks were shortened to a length such that the motion was rendered accessible for oiling. The cylinders were 16in. by 20in., the coupled wheels 5ft. diameter, leading wheels 3ft. 6in., wheel base 6ft. 6in. + 7ft. The outside frames were of the sandwich type, and the inside frames extended backwards to the fire-box casing. The side tanks were supported by the outside frame and were fastened to gussets which, in turn, were riveted to the fire-box casing. There was also a

well tank under the coke bunker, connected to the side tanks by a large pipe outside the frames.

A small 2-4-0 well tank engine of unique design was shown by E. B. Wilson and Co. in the London Exhibition of 1851—Fig. 121. The peculiarity lay in the boiler, which had two separate barrels and fire-boxes side by side.

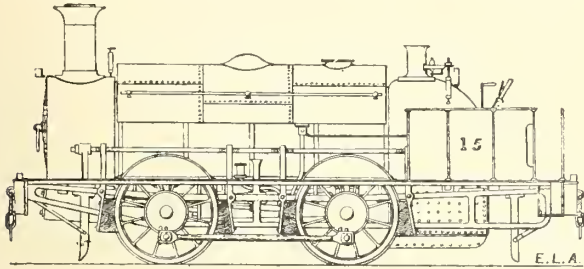

FIG. 122—SHREWSBURY & CHESTER RLY. ENGINE, 1847

There was one common smoke-box and both fire-boxes were enclosed within a single casing. The object of the arrangement was not mentioned beyond the statement that firing was to be performed alternately in each box, in which case the principle was similar to that evolved at a later date by Cudworth for coal burning. But whether coal was intended to be used in Wilson's engine is doubtful, and for coke burning the complication was unnecessary. Each boiler barrel was 1ft. 9in. diameter and the two contained 136 $\frac{3}{4}$ in. tubes, of which the heating surface was 694 square feet; total heating surface, 755 square feet; grate area, $7\frac{1}{2}$ square feet. The cylinders were 12 $\frac{1}{2}$ in. by 18in. and the coupled wheels had a diameter of 5ft. This engine was the only one of the type which appears to have been built, and the writer has no record of its subsequent history. The drawings were made by David Joy.

It was only after 1853-54 that the useful four-coupled tank engines really came into their own and began to replace those with single driving wheels. The North London Railway set the example, and the first ten engines for that line, built in 1853-54 by Stothert and Slaughter, of Bristol, were of the 2-4-0 outside cylinder type. They were followed in 1855 by other types, of which mention will be made subsequently.

The four-wheeled, or, in fact, any class of shunting tank engine, was extremely rare. The earliest of which the writer has any knowledge was Bury's 0-4-0 saddle tank engine with inside cylinders and bar frames, built in November, 1847, for the Shrewsbury and Chester Railway. This engine, with its peculiar lever brake gear actuated by right and left-handed screws, is illustrated by Fig. 122. A four-wheeled tank engine was built by Sharp Bros. in 1849 for the same railway. The small tanks were hung on each side at the front and held only 470 gallons, and when the water capacity was found to be insufficient a similar pair of tanks were added behind the driving wheels at the back. The wheels were 4ft. 6in. diameter and

the wheel base 8ft. long. The cylinders were 15in. by 22in., with valves beneath their centre line, the valve spindles being bent to pass below the leading axle. The entrance to the footplate was on the left-hand side only.

Most of the few tank engines used at this time for shunting and light goods traffic were of the intermediate shaft type previously described, but it was many years before tank engines were considered necessary for shunting duties. In 1854 Messrs. Stothert and Slaughter built six 0-6-0 well tank engines—Fig. 124—for the main line coal traffic of the Mommouthshire Railway. They had outside horizontal cylinders, 16in. by 22in., and to obtain connecting-rods of sufficient length the latter drove a trailing pair of wheels, 4ft. 6in. diameter, placed behind the fire-box.

Engine Brakes.—This subject may be mentioned here. Tender engines had no brakes on the engine wheels, the tenders only being fitted with them. This was the universal practice until about 1876, when the use of continuous brakes subjected such a strain upon the engine drawbars that it was found to be necessary to apply a retarding force to the engine itself. There was, in addition, a strong objection to the application of brake power to driving wheels on account of the torsional stresses on the axles. Possibly for this reason some of the early 2-2-2 tank engines of 1850-51, such as those on the Dublin and Drogheda Railway, were entirely unbraked, reliance being placed entirely upon the guard, who applied his van brake on a whistle signal from the driver. When standing in sidings the engine wheels were scotched. As this was dangerous, it became the usual practice, both in the case of single and coupled tank engines, to apply a clasp brake to the trailing wheels only, leaving the driving wheels free, a method which for coupled engines of the 2-4-0 type threw a strain on the coupling rods. D. Gooch, in the Great Western 4-4-0 tank engines, tried to avoid this difficulty by applying rail skid brakes as mentioned previously.

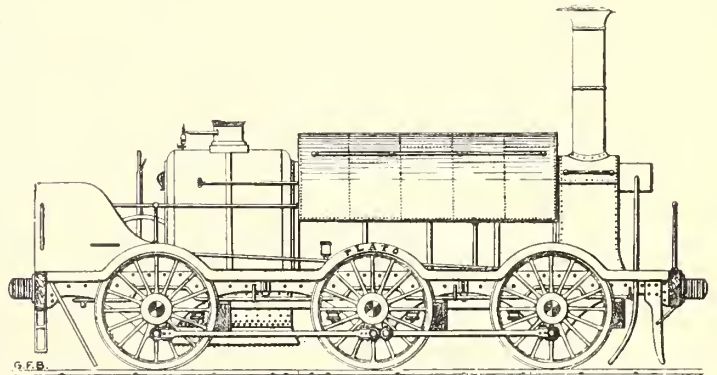

FIG. 123—BROAD GAUGE TANK LOCOMOTIVE, G.W. RLY., 1854

Broad-gauge Tank Locomotives.—On the Great Western Railway no important alterations were made between 1849 and 1854 in the designs of

the main line tender engines, and the only novelty consisted of four heavy 0-6-0 saddle-tank locomotives which in most details were similar to the tender goods engines. They are shown by Fig. 123. The inside frames were of the sandwich type. The most noticeable feature was the use of compensating levers between both pairs of wheels placed below the frames. The goods tender engine, on the other hand, had the more reasonable arrangement of levers between leading and driving springs only. These engines had 17in. by 24in. cylinders, 5ft. wheels, and a total heating surface of about 1574 square feet, pressure 120 lb. A single sand box was placed centrally in front of the smoke-box and the fireman had to ladle the sand down the two pipes with which it was provided. These locomotives were classed as "banking" engines.

A still more powerful class was built in 1856 for the Vale of Neath Railway by the Vulcan Foundry, with 18in. by 24in. cylinders and 4ft. 9in. wheels. These engines had inside plate frames, and compensating levers between leading and driving springs only. In place of Gooch's stationary link motion they were fitted with Dodds's wedge motion as modified by Henry Dübs, then manager of the Vulcan Foundry. The modern form of expansion angle iron bracket riveted to the fire-box and resting on the frames was used. Total heating surface, 1417.6 square feet; weight, 40 tons in working order.⁷ They were too heavy for the rails and were afterwards altered to tender engines.

Bristol and Exeter Railway, Broad Gauge Double Bogie Express Tank Engines.—In his evidence before the Gauge Commission in 1845, Benjamin Cubitt, then locomotive superintendent of the Brighton, Croydon and Dover Joint Committee, made the following statement:—

"I think the driving wheels may soon get too high for safety, except you have plenty of other wheels to keep on the road with. You may get the driving wheels of any height . . . if there are ten wheels, it would perhaps be all the better. Two fours on bogie frames and a pair of drivers would be a very safe carriage."⁸

Whether J. Pearson, locomotive superintendent of the Bristol and Exeter Railway, was inspired or influenced by Cubitt's suggestion is not known, but he certainly designed the 4-2-4 express tank engines, eight of which were built by Rothwell, of Bolton, in 1853-54, and in their original condition are illustrated in Fig. 125. They may certainly claim to have been the boldest departure made up to that time from the accepted canons of locomotive design, other than perhaps Trevithick's "Cornwall" and Crampton's "Liverpool." Some sectional illustrations of these engines as built in

1853—not 1868, as stated—were given in *The Engineer* Supplement, December 16th, 1910, page vi. But no description of them, beyond the meagre details in Colburn's "Locomotive Engineering," page 73, has ever been given, and the following account of their constructional details may therefore be of interest.

The cylinders were 16½in. by 24in.; driving wheels (flangeless), 9ft. diameter; bogie wheels, 4ft. diameter; wheel base, 5ft. 9in. + 6ft. 7½in. + 6ft. 7½in. + 5ft. 9in. = 24ft. 9in. The boiler was of small size for a broad-gauge engine, the barrel being 10ft. 9in. long by 4ft. 0½in. inside diameter, with 180 tubes 1½in. diameter. The writer can find no record of the heating surface and boiler pressure. Colburn gave the weight

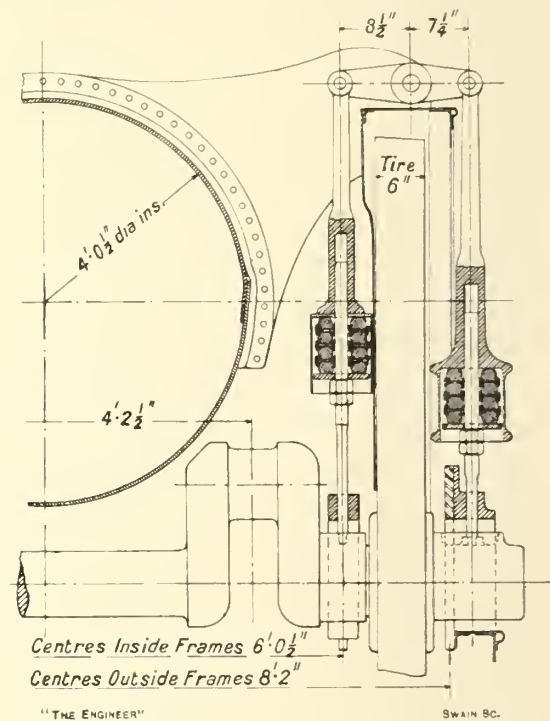

FIG. 126.—SPRING GEAR, BRISTOL & EXETER RLY.

loaded as 42 tons, presumably with the tanks full. It may be noted that the wheel base shows a symmetrical arrangement, in spite of which the engines are stated by Colburn to have run with great steadiness. There were several peculiarities of design. The smoke-box was extremely short and the cylinders projected outside about 1ft. towards the front. The inside plate frame extended from the front buffer beam to the front of the fire-box, and was only 8in. deep for the greater part of its length except at the driving hornblocks. An arrangement of angle plates, 2ft. deep, was fastened to the side of the fire-box and to the front of the well tank. From this point to the back buffer beam there was no frame at all. The inside bearings were only 5in. long, and therefore additional outside bearings, 9in. long, were pro-

⁷ Drawings of these engines are to be found in "Recent Practice of the Locomotive Engine," by D. K. Clark and Colburn, 1860, plate 31.

⁸ Gauge Commission Report, Question 1512, page 93.

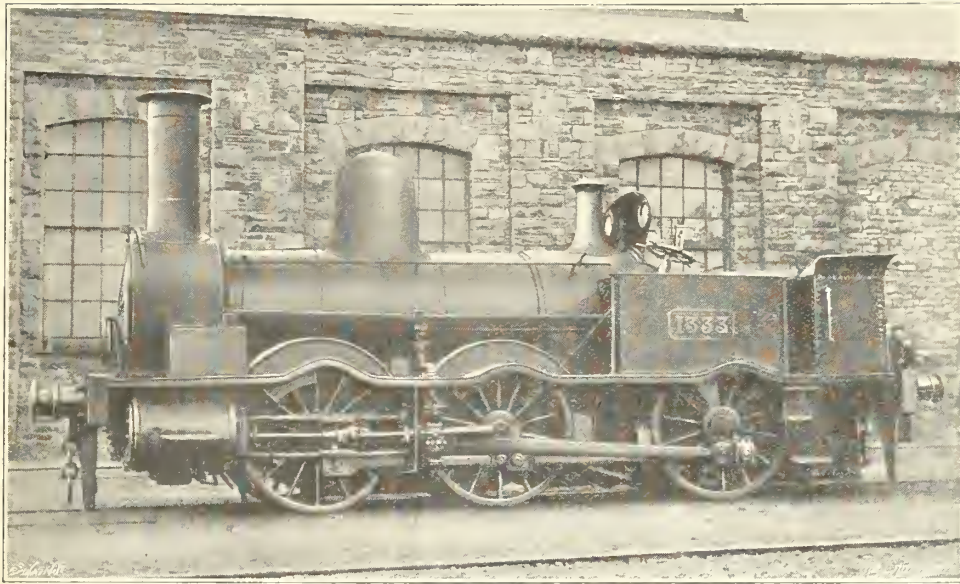

FIG. 124—STOTTIERI AND SLAUGHTER'S ENGINE FOR THE MONMOUTHSHIRE RLY., 1854

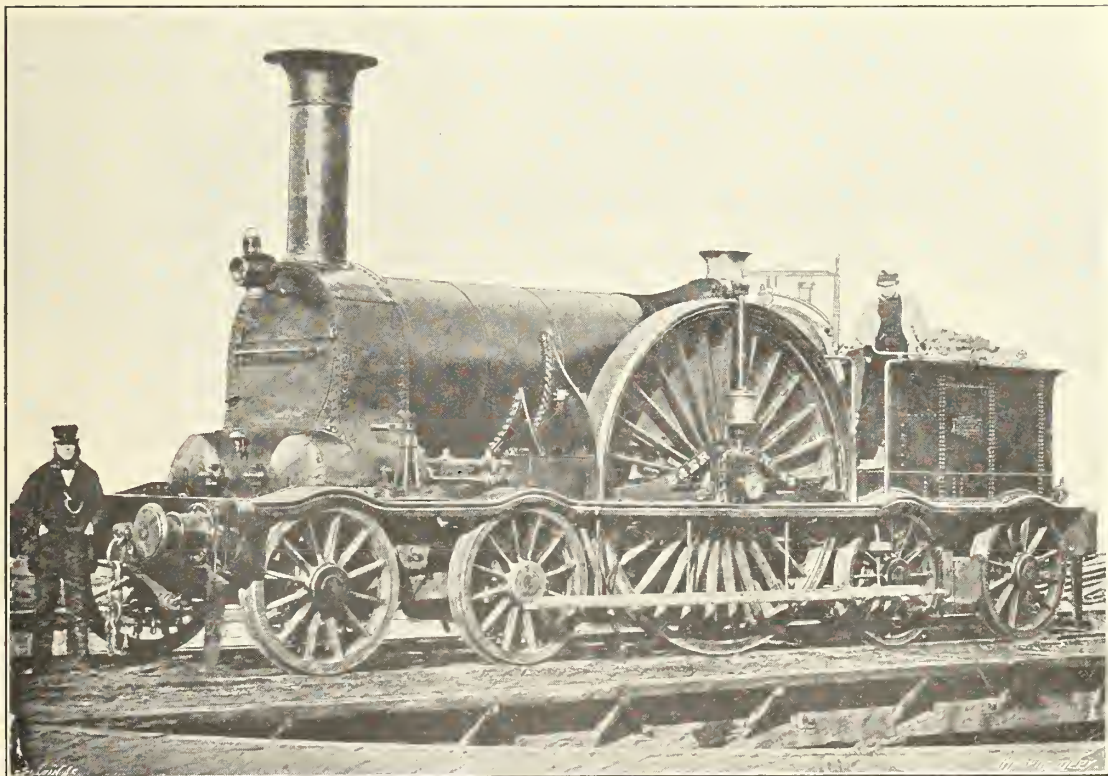

FIG. 125—PEARSON'S ENGINE FOR THE BRISTOL & EXETER RLY., BUILT BY ROTHWELL & CO., 1853

vided, the hornblocks of which were riveted to the triangular queen truss "frame," shown outside the driving wheel in the illustration. This outside frame was, in turn, riveted to an angle iron at the back of the platform, a very light form of attachment. To avoid transmitting the load through this frame to the platform, a special and unique form of spring gear—Fig. 126—was adopted. Both inside and outside springs each consisted of four india-rubber discs separated by plates and enclosed within a casing, which in the outside spring was solid with the long spring pillar, and in the inside spring was riveted to a flat foot forged on the pillar. The inside pillar was 2ft. 10in. long, and the outside one 2ft. 4½in.

on the two sides of the engine were fixed in a heavy saddle bracket, which was riveted to and spanned the boiler. The boiler itself was rigidly fixed to the inside frames by means of the large brackets shown in Fig. 125, and therefore the spring-borne load was transmitted between the springs and the inside frames through the boiler.

Each bogie wheel had an independent india-rubber spring. The bogies were of the Gooch ball-and-socket type, without lateral play, but their wheel base was somewhat longer than in Gooch's bogies. The ball of the leading bogie was secured to the underside of the cylinders by means of a casting with wings, to which two horizontal tie rods were fastened; the other ends of the

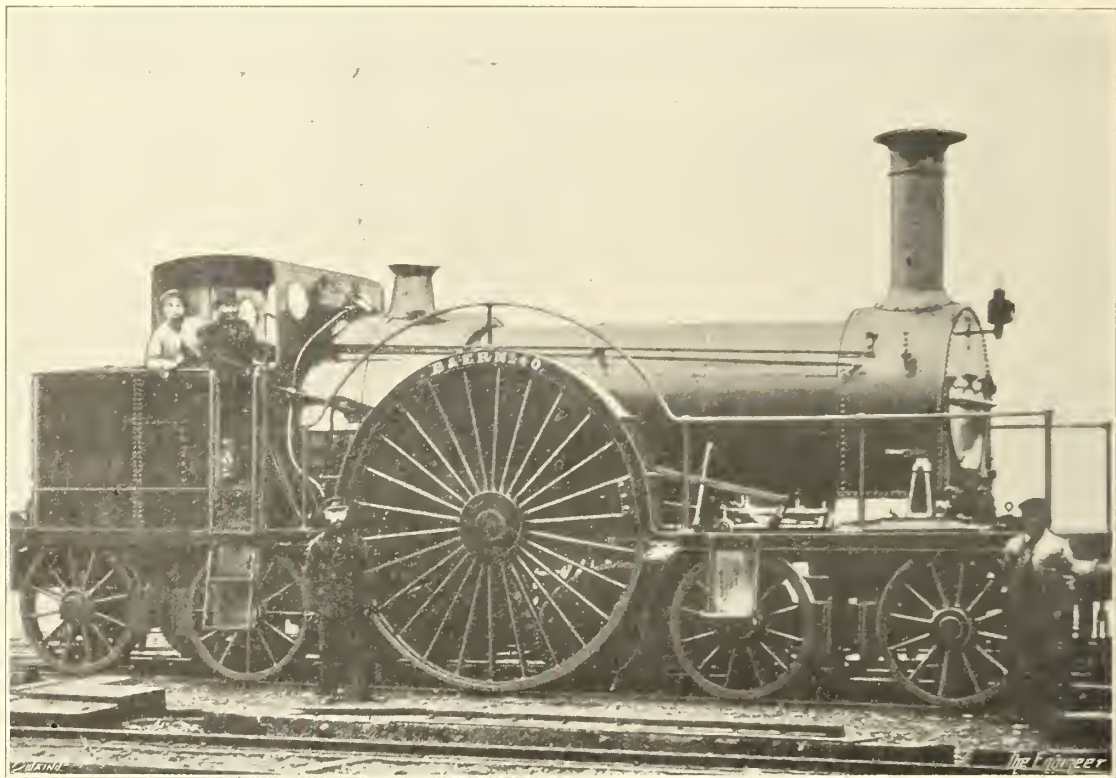

FIG. 127—PEARSON'S ENGINE FOR THE BRISTOL & EXETER RLY., BUILT AT BRISTOL, 1868

long from the top of the rubber spring to the eye for the lever. At the bottom they were widened out to 3in. diameter, and made hollow to take the 1½in. spindles, which by their vertical movements inside the pillars compressed the springs. The top portion of the inside spindle tapered from 2in. to 1¾in. diameter, and that of the outside one, which bore the greater load, tapered from 2¼in. to 2in. diameter. The spindles appear weak in that they were long thin columns under compression. At the top the inside and outside spindles were connected by a double-armed lever, the length of the inside arm being 8½in., and that of the outside arm 7¼in., to equalise the spring pressures on each side of the fulcrum. The fulcra

latter were secured to the bogie side frames, and prevented the bogies from slewing round across the track. In the absence of main frames at the trailing end, the ball pivot of the trailing bogie was simply riveted by means of a plate in the form of a cross, to the underside of the tank. No tie check rods were provided at this end. Brake blocks worked by a screw from the footplate were provided between the wheels of this bogie.

The history of these remarkable engines has never been correctly recorded. In 1868-73, after an average life of about sixteen years, all the eight original Rothwell engines were scrapped, a fact which shows that they left something to be desired. Four new engines—Fig. 127—in which

practically nothing of the originals remained, were built at Bristol in their place.

The differences in design are of considerable interest. The old 16½ in. by 24 in. cylinders, spaced at 4 ft. 2½ in. centres, gave place to 18 in. by 24 in.

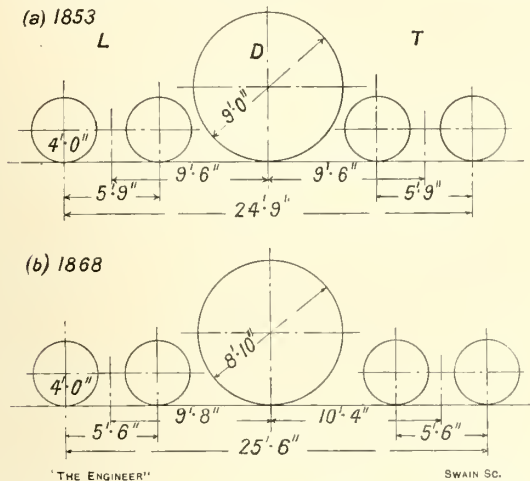

FIG. 128—WHEEL ARRANGEMENTS FOR TANK ENGINES, BRISTOL & EXETER RLY.

cylinders at 3 ft. 6 in. centres, thus involving new crank axles. The diameter of the driving wheels, which had flangeless tires, was reduced from 9 ft. to 8 ft. 10 in., and the centres were new. The bogies also were new, and the wheel base of each was 3 in. shorter. The diagrams—Fig. 128—show the two wheel arrangements, and it will be noticed that instead of the original symmetrical wheel base, the driving wheels were nearer to the leading than to the trailing bogie. The coal bunker and tank were shorter but deeper. It is an interesting, though doubtful, speculation whether the symmetrical wheel base of the old engines had produced unsteady running, and whether the alterations may have been partly due to this cause. On the other hand, the boiler and fire-box casing were about 11 in. longer in the new engines, and a redistribution of weight was probably the primary cause of the modification. The framing was entirely new; the old outside bearings and complicated spring gear, with india-rubber springs, were discarded, and a new simple inside plate frame extending from front to back buffer beam was used with plate springs above the driving axle. The new bogies had independent elliptical plate springs below each axle, and all the bogie wheels were braked. The smoke-box was lengthened and enclosed the cylinders completely. The fire-box casing was raised above the barrel, whereas in the old engines it had been flush. The new boilers had a tube heating surface of 1088 square feet; fire-box was 147 square feet; total, 1235 square feet; grate area, 23.1 square feet; the weight in working order was 15 tons 8 cwt. on the leading bogie, 18 tons 10 cwt. on the driving wheels, and 15 tons 16 cwt. on the trailing bogie, total 49 tons 14 cwt.

The fire-box was provided with transverse water tubes, and another interesting detail was an arrangement whereby the blower in the chimney was opened automatically by the closing of the regulator. Some drawings of the later new engines, with details, were given in *The Engineer*, May 9th, 1890, to which reference may be made.

The great weight, 18½ tons, on the driving wheels, which were without counterweights, is worth noting. In July, 1876, one of these engines, when working the up "Flying Dutchman," ran off the rails near Bourton, the cause being defective permanent way. After this accident, their career as tank engines ended, and the Great Western, into whose hands the Bristol and Exeter Railway had passed, converted them into 4-2-2 tender engines, the trailing bogie being replaced by a single axle with 4 ft. 6 in. wheels under the footplate. The driving wheels were reduced to 8 ft. diameter, and the weight on them was also reduced. In this form two of them ran until the abolition of the broad gauge in May, 1892.

There were two somewhat similar 4-2-4 tank engines with 7 ft. 6 in. wheels, one of which, G.W.R. 2005, built in 1862, remained in its original condition until broken up about 1887.

MISCELLANEOUS DETAILS OF CONSTRUCTION, 1846 TO 1855.

A number of details have been mentioned in the foregoing descriptions of particular engines, and therefore under this heading it will be necessary to refer only to additional items.

The inconvenient general design of goods engine with inside cylinders inclined upwards and slide bars beneath the leading axle held its own until the end of 1850, when it was finally discarded. It would probably have been given up before had not the best arrangement of inside cylinders with common steam chest between them been patented, by R. Stephenson and Co., in 1841, and in preference to paying royalty, some

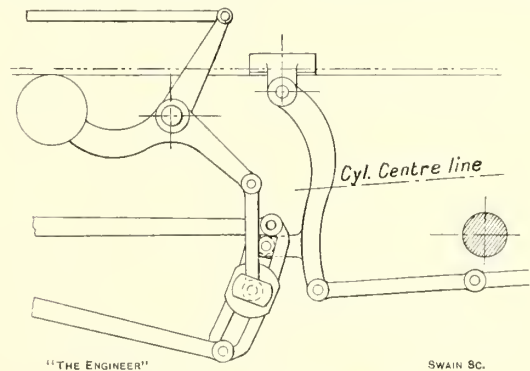

FIG. 129—VALVE GEAR, 1846 TO 1852

engineers gave the running shed staffs extra work in having to take down the slide bars, connecting-rods, and the whole of the motion when the engine had to be lifted to repair the axle-boxes. On the other hand, this inconvenient design allowed the

boiler to be placed lower in the frames than when the valves were above, and there appears also to have been an additional reason in that Stephenson's inside steam chest was then thought to be suitable only when the cylinders did not exceed 16in. diameter, but that for 17in. and 18in. cylinders it was either too narrow or the cylinder centres had to be spaced further apart, to the detriment of the crank web thicknesses. Consequently Sharp's engines of 1846-49, with 18in. cylinders, were designed as a compromise. The cylinders were placed at 2ft. 3in. centres and inclined downwards, with the slide bars above the leading axle, but the valves were below, the port faces forming a Λ . Only the valve spindle drag link passed underneath the leading axle, but as it was jointed by pins at each end, it was easily disconnected when the engine had to be lifted. In 1852 Matthew Kirtley designed twenty goods engines for the Midland Railway with 17in. by 24in. cylinders, which were built by Stephenson and Kitson; in these a similar valve gear—as shown by Fig. 129—was used. The back end of the drag link was suspended from a bent swinging lever to a projection on which the die block was attached. The expansion link was suspended from a trunnion in the middle and on the outside only of the link. McConnell also used this motion in his 18in. goods engines.

In 1853 Kirtley reduced the size of cylinders in twenty goods engines, generally similar to those of 1852, to 16½in., placed the valves between and adopted the Stephenson direct motion now usual. The cylinders were spaced 2ft. 6in. between centres, the crank webs were 4½in. thick, and the connecting-rod bearings 4½in. long. The

inside axle journals were 6¾in. diameter by 4in. long, and those in the outside frame 6in. diameter by 8in. long.

But Messrs. Stephenson themselves did not always use their patented steam chest between the cylinders, more especially for passenger engines, as is shown by the examples with outside steam chests and eccentrics which have been described.

The 2-2-2 express engine, by Hawthorn, at the 1851 Exhibition, had the modified link motion shown in Fig. 130. In it the expansion link was of extra length, and instead of being pinned to the ends of the eccentric rods and having to be raised and lowered with them, was directly connected by an eye joint to the valve rod, from which it was suspended, so that its weight was removed from the reversing gear. The eccentric rods were forked and pinned, one to each end of a long slide block movable in the expansion link, the movement being derived from a weigh bar shaft below.

It was claimed that this gear was easier to operate, since less weight had to be lifted when reversing, also that the long slide block increased the durability of the link, and that less head room was needed under the boiler. Nevertheless the use of the gear was never extended, and the similar engines built by Hawthorn in 1852 for the Great Northern Railway had the ordinary Stephenson link motion.

The necessity for expansion brackets for supporting the fire-box casing on the frames, at the same time permitting the boiler to expand when hot, had now become evident. Sharp, Stewart and Co. designed a very complicated arrangement for their 0-6-0 goods engines with double frames, in which two sliding surfaces were provided. A heavy bracket attached to the casing embraced the outside frame upon which it could move, and at the same time the bottom of the foundation ring, which had a convex surface, rested upon a hollowed out angle iron riveted to the inside frame.

Springs.—The plate springs of Stephenson's, Wilson's, Kirtley's, and other engines were usually 3ft. long, and in some 0-6-0 long boiler engines were set at an angle to clear the fire-box casing. In Sharp's engines, until 1850, the spring length was only 2ft. 6in., and in their long boiler engines, rather than set the trailing springs at an angle, their length was reduced to 1ft. 10in. only.

In some of Sharp's inside-framed engines, in which the trailing axle lay behind the fire-box, in preference to taking up room on the footplate with long plate springs, a double spiral spring was used, consisting of external and internal coils of ¾in. and ½in. square section steel respectively. The springs were enclosed within a sheet iron casing as a protection for the men in case of breakage.

Combined india-rubber hydro-pneumatic bearing springs were tried on a railway in South Wales. They consisted of a vertical india-rubber cylinder with thick walls and enclosed within a

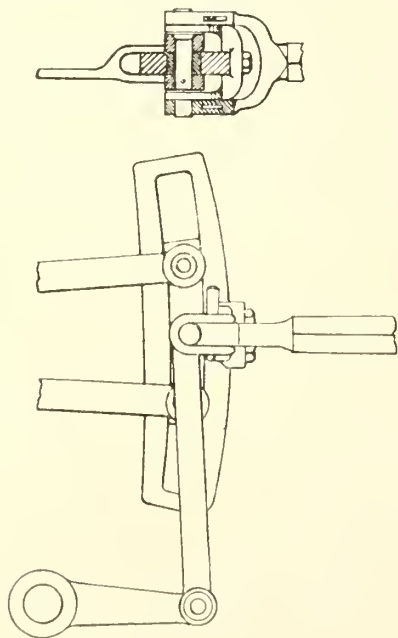

"THE ENGINEER"

SWAIN SC.

FIG. 130—HAWTHORN'S LINK MOTION. 1851

casing. The hollow interior was partially filled with water. As the spring pillar moved upwards the sides of the rubber cylinder bulged inwards, forcing up the water into an enclosed air space above. The compression of the air added an elastic cushion to the spring.

Frames.—Frames have already been considered in detail. The following comparative cost of repairs, covering a period of ten years' work, 1866-75, on the Great Southern and Western Railway, Ireland, of 2-2-2 engines, eleven by Sharp with double frames, and twenty by Bury, Curtis, and Kennedy with inside bar frames, were given by A. McDonnell.⁹ Both types of engine were designed by the makers in 1846-47, and were therefore 20-30 years old. Sharp's engines had 15in. by 20in. cylinders and 5ft. 8in. driving wheels. The boiler pressure was not stated, but would be 80-100 lb. The permanent way during the period covered was in bad condition.

	Eleven Sharp engines. Pence per mile.	Twenty Bury engines. Pence per mile.
Average life per engine, miles ...	465,471	388,028
Running gear repairs—		
Axles007	.000
Tires032	.097
Springs036	.028
Sundries for wheels and frames	.908	.012
Axle-boxes007	.054
Axle brasses013	.007
Total, materials only103	.198
Boiler repairs—		
Copper plates024	.002
Copper stays007	.001
Tubes032	.009
Fire-bars and brick arch023	.047
Sundries for boiler014	.006
Total, materials only100	.065
Total cost of repairs for whole engine, materials and wages ...	1.11	1.13

Bury's boilers referred to above had the D-shaped fire-boxes. Those of Sharp's engines were of the usual type, and had circumferential butt joints with cover strips outside. During this period most other makers constructed their boilers in three rings, of which the middle ring was the largest, but many of these boilers had the defect of two longitudinal lap joints in each ring. Sharp Brothers made their rings with a single longitudinal butt joint with one internal cover strip.

The usual practice was to stay the ends with gussets or stay rods, one end of which was secured to the barrel. Amongst those who discontinued this practice and adopted longitudinal stays between the smoke-box tube plate and fire-box casing were J. V. Gooch on the Eastern Counties Railway, and Robert Sinclair on the Caledonian Railway, though the writer does not know whether they were the first to make this improvement.

Messrs. Hawthorn, though they built many engines with domeless boilers and perforated steam collecting pipes, also constructed a large

⁹ Inst. Civil Engineers, 1876.

number with domes, in which the open end of the steam pipe was protected by a baffle chamber, as shown in Fig. 131. The regulator was placed in the smoke-box.

Blast Pipes.—A variable blast pipe reappeared in Sharp's heavy goods engines of 1848-49. It was similar in principle to that of Rothwell in 1832, and took the form of a hollow internal cone, which could be raised or lowered in the blast orifice by means of a system of levers and rods worked from the footplate. Messrs. Hawthorn also applied a variable blast pipe to some engines built in 1846 for the North British Railway.

Smoke-box Doors.—Smoke-box doors of the double folding type began to give place to single doors. The former were difficult to keep tight, though they were retained on the Midland Railway until 1873, and on the Great Southern and Western Railway (Ireland) until a much later period. The circular dished doors appear on Stephenson's drawings of

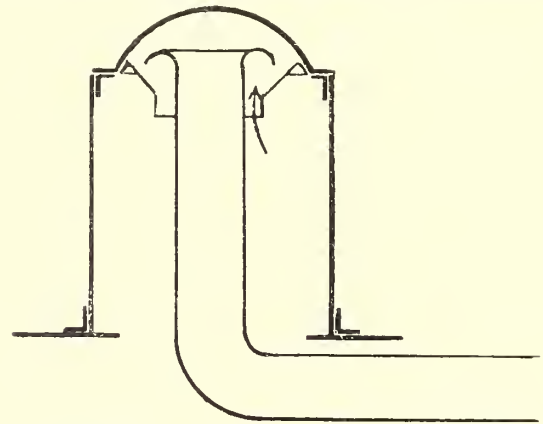

FIG. 131—R. & W. HAWTHORN'S STEAM DOME

the long boiler engines of 1843,¹⁰ and were probably invented by this firm, but they did not come into more extended use until 1847, when they also appeared on Wilson's and Hawthorn's engines. The doors were secured by crossbar and handle. Several locomotive superintendents preferred the Gooch door of \cap form, which opened upwards about a horizontal hinge. These doors, which had an awkward knack of falling unexpectedly, when open, were used on the London and North-Western Railway until 1883, with the addition of a bridle and central bolt.

The grates of the later engines of Bury, Curtis and Kennedy were in two portions. The bars of the shorter back portion were provided with hooks which rested upon rounded projections attached to a cross bearer in such a way that by withdrawing a bolt worked by a lever from the footplate, this portion of the grate rotated about the bearer, and the fire could be dropped quickly.

Gauges.—Gauge glasses with automatic ball valves appear to have been first used between 1851 and 1855, but the original suggestion is stated to

¹⁰ Illustrations given by Warren, pages 352 and 354.

have been due to the eminent German Professor Reuleaux, whose idea was carried out by Schebesta on the Austrian Kaiser Ferdinand's Nordbahn.

Steam pressures, which in 1845-49 were 100 lb. per square inch, had risen to 120 lb. in 1852, though, as mentioned previously, both McConnell and Sturrock used 150 lb. in many of their engines from 1851 onwards.

Crank Axles.—About 1851 Sturrock and Hawthorn introduced the practice of shrinking hoops over the webs of crank axles, and in 1853 David Joy, then locomotive superintendent of the Oxford, Worcester and Wolverhampton Railway, passed a bolt through each crank pin as a safeguard in case the crank axle broke. The latter improvement subsequently remained in abeyance many years, until S. W. Johnson re-introduced it on the Midland Railway.

Pistons.—The Ramsbottom dished piston with narrow spring rings made its appearance during this period, about 1852.¹¹ For some years they were used on the North-Eastern Division of the London and North-Western Railway, of which Ramsbottom had charge of the locomotive department at Longsight, Manchester. Three narrow steel or iron rings, $\frac{1}{4}$ in. wide, were used at first. In later years two broader rings of cast iron became standard practice.

Connecting-rods.—The long forked connecting-rod was frequently used by Stephenson until about 1855 on both inside and outside cylinder engines, and rods with short forks, as introduced by Alex. Allan, were the practice on the Crewe-built engines of the London and North-Western, and on several of the Scottish railways. Connecting-rod ends with gibs and cotters and dovetailed straps were general. Both Stephenson and Sharp added bolts to secure the strap, and from this practice there was evolved the present standard big-end for engines with inside cylinders, on the appearance of which the dovetailed straps with their sharp corners, always a source of weakness, began to disappear, except on the London and North-Western Railway. The writer cannot say who originated the modern big-end with cotter and two bolts, but it was applied to Matthew Kirtley's Midland goods engines of 1852, which were built by Stephenson and Kitson.

Valve Gears.—The Caledonian Railway tank engines of 1853-54, by R. Sinclair, with intermediate driving shaft, mentioned previously, had Gooch outside valve gear, arranged similarly to the system so frequently adopted on the Continent. There have been very few cases of outside excentric valve gears in this country, where they originated, and these were confined to Crampton's and a limited number of early Caledonian engines, with one example by J. Beattie on the L. and S.W.R. and the Stephenson and other exceptions already described. The sides of the tanks of the Caledonian engines were formed by the main frames between the smoke-box

and fire-box, a method adopted about fifteen years later by Krauss and Co., of Munich. The ends of the tanks formed transverse frame stays.

Sand-boxes.—Most sand-boxes were of a primitive form. In D. Gooch's saddle tank passenger engines of 1849 the sand-box was placed on the top of the saddle tank and arranged as in Fig. 132, with a funnel near the top, out of which two branch pipes descended to the front of the driving wheels. There was no method of working it from the footplate, and the fireman had to get on to the top of the tank to ladle sand down the funnel. In some later tank engines of 1852 the single sand-box was transferred to the front of the smoke-box, where the fireman could get at it more easily from the front buffer plank. Subsequently, a sand-box was placed on each side of the engine platform, in front of the leading wheels. But in Sharp's goods engines of 1848 we find a modern sand-box on each side under the platform, in front of the driving wheels, with an outlet valve worked by a rod from the footplate.

Tenders.—In regard to tenders, several designs have been shown in the preceding illustrations, and the four-wheeled tender with inside bearings—Fig. 56 *ante*—by the Vulcan Foundry may be noted. The same firm in 1845 constructed a tender for a German railway, in which the water was contained in a cylindrical "boiler" tank.

Here a word of caution is perhaps necessary. The student of the history of locomotive details sooner or later discovers that "there is nothing new under the sun." Without putting too literal a meaning upon this, it is undoubtedly the case in many instances that improvements ascribed to particular engineers are found to have been tried by others at an earlier date. As an example of this, wind deflectors on the front of the chimney top may be instanced. These are frequently supposed to have been of French origin, but some of George England's engines of 1851 were fitted with them. Unfortunately, England applied them to tank engines, on which, when running bunker first, the deflectors were worse than useless, owing to the down draught produced, and were consequently discarded. Many French tender engines were subsequently supplied with them, but they did not reappear in this country until F. W. Webb revived them at the end of last century.

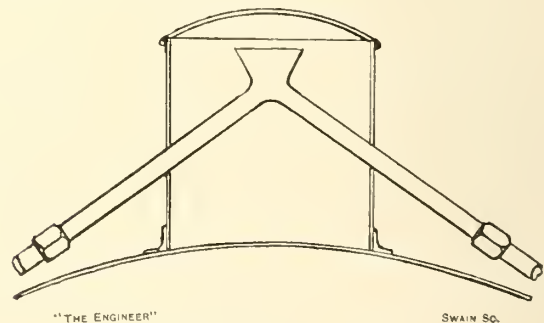

FIG. 132—SANDBOX, D. GOOCH, 1849

¹¹ This date was given by W. P. Marshall, "Proc. Inst. C.E.," Vol. 133.

Chapter IX — 1855-59

THE principal events of this period were the first introduction of the four-wheels coupled *express* engine, the success of which at that time was very doubtful, the more extended use of the bogie, and, finally, the victory, after long-continued experiments, of coal over coke for locomotive fuel. The subject of coal burning will be dealt with in a subsequent chapter.

Although Matthew Kirtley from 1852 onwards always used outside plate frames and flush fire-box casings for his goods engines, the passenger engines had sandwich frames and raised fire-box casings. The driving horns, as in Sharp's engines, were very short, but unlike Sharp's, were united by stiff rectangular tie bars. The weight in working order varied from 28 to 28½ tons.

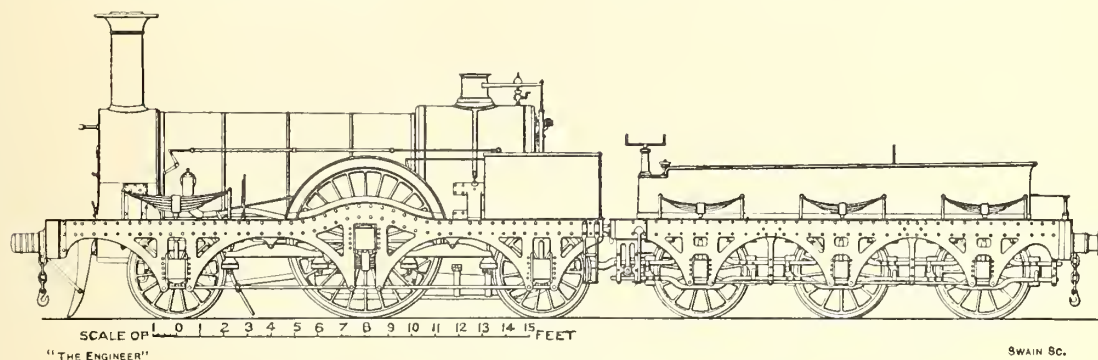

FIG. 133—G.W. RLY. LOCOMOTIVE, BUILT BY BEYER, PEACOCK & CO., 1855

2-2-2 Express Engines: Inside Cylinders.—A few of the more interesting classes may be briefly mentioned. The first standard gauge G.W.R. engines are shown by Fig. 133. They were built to D. Gooch's designs by Beyer, Peacock and Co., in 1855, and were the first locomotives constructed by this firm, which had just been founded in 1854. Their chief characteristics were the slotted out sandwich frames, and the application of compensating levers between the three axles. The arrangement of india-rubber pads on the spring pillars beneath the levers may be noted. Such pads were always a feature of G.W.R. locomotive practice until recently, as also were the long "open-plated" springs, which for the leading wheels of these engines were 4ft. 6in. long. The writer can bear testimony to the very easy and smooth riding of the engines fitted with these springs. When the above locomotives were reconstructed, the compensating levers were discarded. As originally built, the engines had 15½in. by 22in. cylinders, 6ft. 6in. driving and 4ft. carrying wheels; wheel base, 15ft. 6in. The boiler, 4ft. diameter, contained 193 2in. tubes, and had a total heating surface of 1112 square feet, of which the fire-box provided 109.8 square feet. The grate area was only 13.6 square feet. The boiler was riveted to the motion plate, but was provided with an expansion bracket at the fire-box end.

The standard Midland express engine, as built at Derby, 1856 to 1861, is shown by Fig. 134. It had 6ft. 8in. driving wheels, 15ft. 6in. wheel base equally divided, and 16in. by 22in. cylinders.

A different design by Beyer, Peacock and Co., 1856, for the Edinburgh and Glasgow Railway—Fig. 136—is characteristic of this firm, and shows the simplicity of design and neatness of appearance which the British locomotive was now assuming. Both inside and outside frames were solid and extended from front to back buffer beams, but the driving axle had inside bearings only. The fire-box was raised slightly above the barrel, but this detail was hidden by the flush clothing. The boiler, like that of Gooch's engine, was domeless, with perforated steam collecting pipe and regulator in the smoke-box. Cylinders, 16in. by 20in.; driving wheels, 6ft. 6in.; carrying wheels, 3ft. 6in.; wheel base, 14ft. 6in., equally divided. The boiler, 3ft. 11in. diameter inside the smallest ring, was pitched 6ft. 7½in. centre above rails; the 171 2in. tubes had ½in. clearance between them. The blast pipe had a 4½in. orifice,

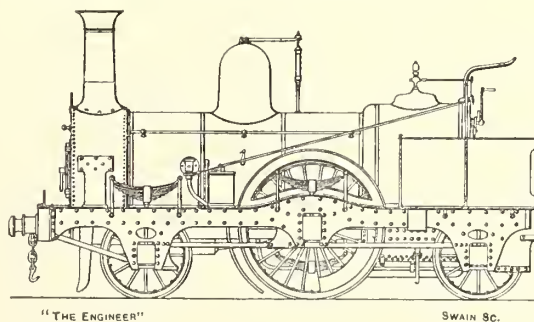

FIG. 134—MIDLAND RLY. LOCOMOTIVE No. 1, 1859

situated just above the top row of tubes, a position decided upon as a result of Peacock's experiments on the Manchester, Sheffield and Lincolnshire Railway, described fully by D. K. Clark.¹ The main crank axle journals were 6½ in. diameter by

peculiar to all the Beattie passenger engines until 1875. The trailing wheels had ordinary outside bearings only, so that the journals were removed from the influence of the heat of the fire-box. The valves were above the cylinders and actuated

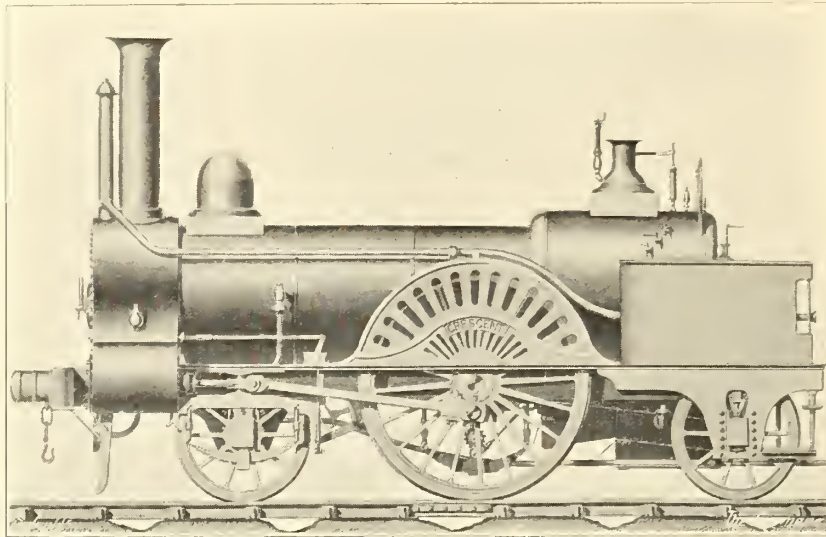

FIG. 135—J. BEATTIE'S L. & S.W. RLY. LOCOMOTIVE, BUILT AT NINE ELMS, 1856

7¾ in. long. These engines, which were re-boilered by D. Drummond in 1880 on the N.B.R., had a life of more than fifty years.

2-2-2 Engines: Outside Cylinders.—Joseph Beattie's engines of the "Canute" class—Fig. 135—were built at Nine Elms in 1855-56, and were fitted with his patent feed-water heating apparatus, with condenser in front of the chimney, and also with a combustion chamber between the fire-box and boiler barrel. The leading wheels had inside main bearings, but were also provided with small outside steadying bearings, which carried only a very small proportion of the weight.

by rocking shafts and inside Stephenson gear. The cylinders were 15 in. by 21 in.; driving wheels, 6 ft. 6 in.; leading wheels, 3 ft. 6 in.; trailing wheels, 3 ft. 7½ in. diameter; the boiler barrel contained 373 tubes, 1¼ in. outside diameter, 6 ft. long. The back portion of the barrel contained the flat-roofed combustion chamber, 4 ft. 2 in. long by 3 ft. 6 in. diameter; heating surface, tubes 625 square feet, combustion chamber 37 square feet, fire-box 107 square feet, total 769 square feet; fire-grate in two parts, 16 square feet total area. Of the total weight of 28 tons 9 cwt., only 9 tons 9 cwt. were normally available for adhesion. This

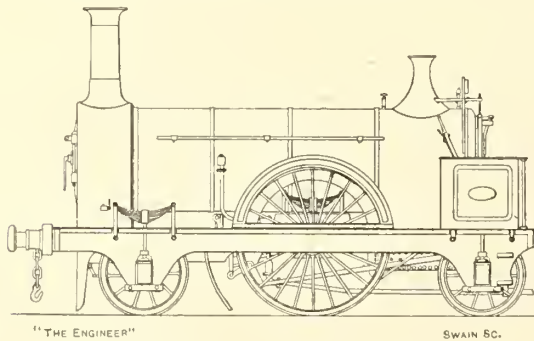

FIG. 136—EDINBURGH AND GLASGOW RLY. ENGINE, BY BEYER, PEACOCK & CO., 1856

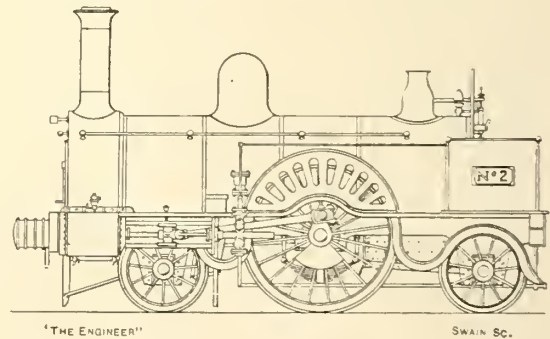

FIG. 137—P. STIRLING'S G. & S.W. RLY. ENGINE, BUILT AT KILMARNOCK, 1857

These outside axle-boxes were without guides, and the underhung springs took their load from the bottom slide bars. This arrangement was

¹"Railway Machinery," page 134.

inefficient weight distribution, caused partly by the weight of the condensing apparatus, both within and without the smoke-box, and partly by the necessity of placing the leading wheels some-

what far back to clear the outside cylinders, was possibly the reason for the abandonment of single-driver express engines by the L. and S.W.R. in favour of four-coupled engines as early as 1859, after which year no more "singles" were built. This railway was the first to discard the "single" engine.

That Beattie considered that the weight on the drivers might require modification seems to be shown by the peculiar arrangement of worm and worm wheel interposed between the spring buckle and the axle-box keep.

Fig. 137—is of interest in that it was the first express engine designed by Patrick Stirling, then locomotive superintendent of the Glasgow and South-Western Railway. It was also the first engine to be built at this company's works at Kilmarnock in 1857. This type, with outside cylinders and inside bearings throughout, appears to owe its origin partly to the old engines—Fig. 41 *ante*—built in 1839 by Messrs. Stirling, of Dundee, and partly to P. Robertson, Mr. Stirling's predecessor on the G. and S.W.R. In the design we see the genesis of the famous 8ft.

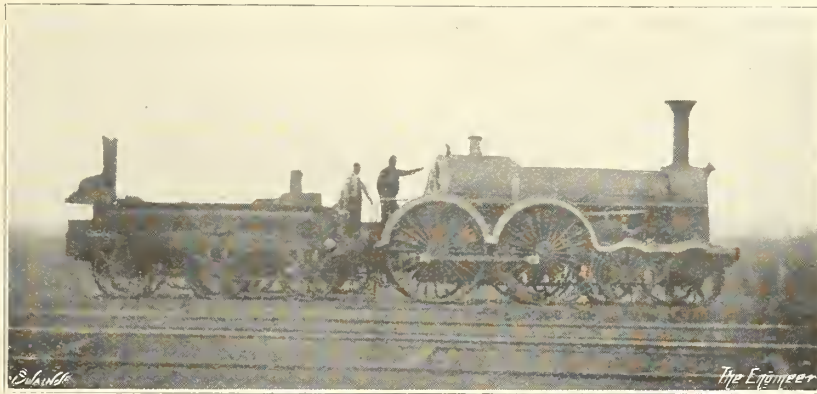

FIG. 138—G.W.R. BROAD GAUGE LOCOMOTIVE "CŒUR DE LION," BY D. GOOCH,
BUILT BY R. STEPHENSON & CO., 1855 (From a photo lent by Mr. H. V. Pegg)

Another peculiarity was the bent pipe shown underneath the smoke-box, which terminated in a large bell-mouthed end open to the front. The other end of the pipe terminated inside the smoke-box in the blast orifice, at the junction of the breeches exhaust pipes from the two cylinders. The idea appears to have been to assist the blast by means of an additional air draught through

singles of a later Great Northern period, but in 1857 Stirling used a domed boiler, and it was not until 1860 that he built several similar engines without domes. Until 1865 the engine illustrated was the standard express locomotive on the G. and S.W.R. The cylinders were 16in. by 21in., and the driving wheels 6ft. 6in. diameter.

Four-wheels Coupled Express Engines.—Although four-coupled engines had been in service for many years, their use had been confined to ordinary passenger and goods trains, and their wheels did not exceed 6ft. in diameter. In the engines about to be described the diameter of the wheels was increased to 6ft. 6in. and 7ft.

For the 7ft. gauge of the Great Western Railway D. Gooch designed the engines—shown in Fig. 138—ten of which were built in 1855 by Messrs. Stephenson. They were not intended to replace the 7ft. and 8ft. singles on the main line between London and Bristol, but were built to run the faster trains between Swindon and South Wales, where on some sections, especially between Swindon and Gloucester, the gradients are severe. The speeds of these trains were only moderate. Although the wheel arrangement was of the 4-4-0 type, there was no leading bogie, and, like the 8ft. single engines, the two pairs of leading wheels were rigid. The frames were of the sandwich type, but placed inside the wheels. The cylinders were 17in. by 24in. and the driving wheels were 7ft. diameter, the first of this size to be used for

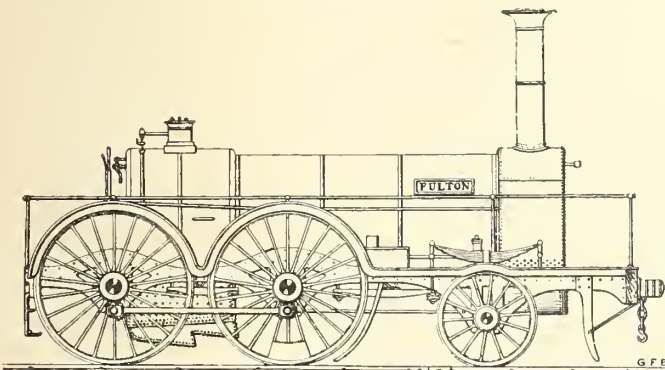

FIG. 139—GOOCH'S G.W. RLY. BROAD GAUGE 2-4-0 EXPRESS ENGINE, 1856

the orifice, thus making up for the exhaust steam taken for feed-water heating.²

One other engine of the outside cylinder type—

² Sections of an engine of this class may be found in "Proc." Inst. C.E., Vol. XVI, Plate I.

a coupled engine. The carrying wheels were 4ft. 3in. The total wheel base, which was rigid, was 17ft. 11½in., the coupled wheel base being 7ft. 5in.; boiler, 4ft. 6in. diameter; heating surface of tubes, 1444.2 square feet; of fire-box,

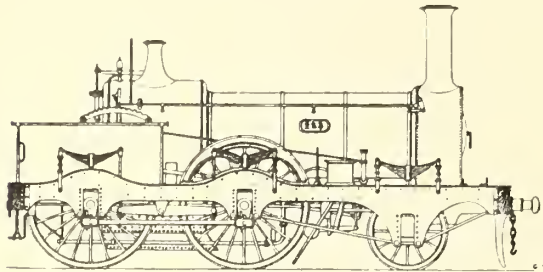

FIG. 140—2-4-0 EXPRESS ENGINE, GREAT NORTHERN RLY.,
BY R. & W. HAWTHORN, 1855

129.8 square feet; total, 1574 square feet; grate, 19.2 square feet; total weight in working order, 36 tons 13 cwt. 2 qr., of which 21 tons 12 cwt. were available for adhesion.

It cannot be said that these engines were a success for express work, though they proved fairly useful for excursion and other heavy passenger service. They were never rebuilt; two were broken up in 1872, and the others in 1876, their average mileage amounting to 497,200. The type was not perpetuated.

The following year, 1856, D. Gooch built eight 2-4-0 fast passenger engines at Swindon, followed

13 cwt. These engines also had sandwich frames inside the wheels. They were scrapped after about fifteen to twenty years service, though their early disappearance may be connected with the reduction of broad-gauge mileage, owing to the conversion of many sections of the railway to standard gauge in 1872-74.

Briefly stated, the four-coupled engine never succeeded in establishing anything like equality with the single engine on the Great Western broad gauge.

Three types of 2-4-0 express engines on standard-gauge railways merit mention. The first were Hawthorn's engines—Fig. 140—built in 1855 for the Great Northern Railway. They had double frames, the outside frames being of the sandwich pattern. The cylinders were 16½in. by 22in.; coupled wheels, 6ft. 6in.; wheel base, 15ft. 9in.; fire-box heating surface, 110 square feet; total, 982 square feet; weight in working order about 33 tons.

These engines were not intended to supersede the "singles," which on the Great Northern until the closing years of the nineteenth century remained unrivalled. The coupled engines worked some of the heavier "fast" main line trains at lower speeds, and of the inside cylinder type of that day were probably the most successful.

The Midland also tried coupled express engines. The then existing main lines of this company, with the exception of the section between Birmingham and Bromsgrove, were well suited for single

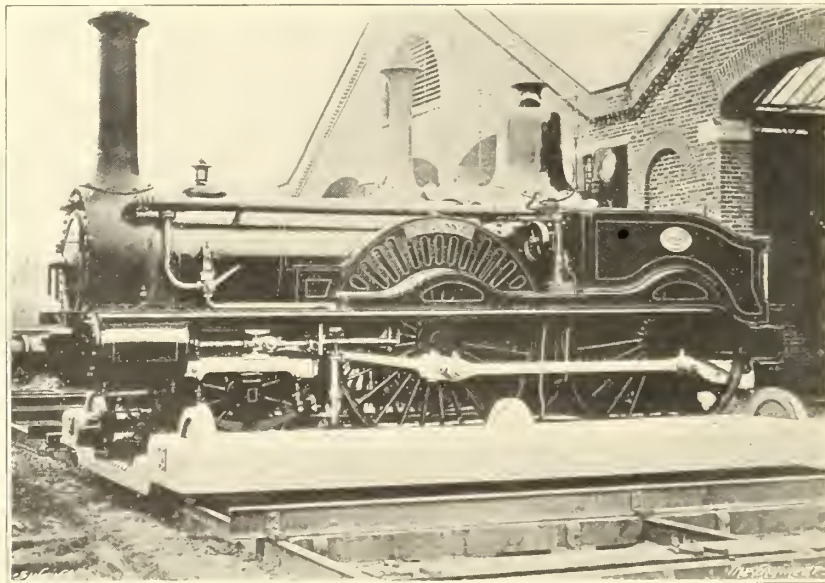

FIG. 141—J. BEATTIE'S L. & S.W. RLY. LOCOMOTIVE, BUILT AT NINE ELMS, 1859

by ten of the same class in 1863-4—Fig. 139. They were of much more modest dimensions than the type previously described, and had 16in. by 24in. cylinders and 6ft. 6in. coupled wheels; heating surface, 1263 square feet; total weight, 30 tons

engines, until in 1857 the Leicester (Wigston) to Hitchin line was opened, the gradients on which, between Wigston and Bedford, were much more severe. For the purpose of working the new London expresses, which from February, 1858,

ran on this road between Leicester and King's Cross, four 2-4-0 express engines with double sandwich frames were built at Derby. They had 6ft. 6in. driving wheels and 16in. by 22in. cylinders. As coupled express engines they were a failure, and after about three years' service were converted into single engines similar to the one illustrated by Fig. 134. The reasons for the want of success of coupled express engines will be mentioned subsequently when the subject of single *versus* coupled engines will be more fully discussed.

Joseph Beattie's celebrated 2-4-0 express engines with outside cylinders for the L. and S.W.R., first built at Nine Elms in 1859, are shown by Fig. 141.³ They were the first engines on the standard gauge to have coupled wheels as large as 7ft. The cylinders were 17in. by 22in.; the wheel base, very short for a main line express engine, was 6ft. 2½in.

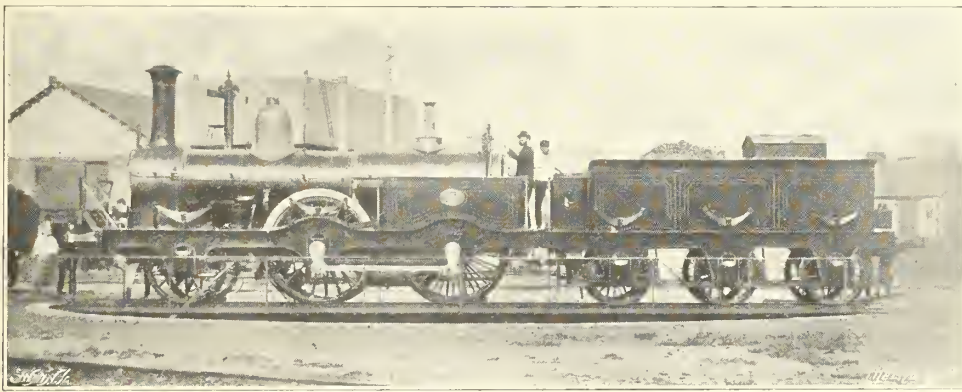

FIG. 142—CUDWORTH'S SOUTH-EASTERN RLY. LOCOMOTIVE, 1859-75

+ 8ft. = 14ft. 2½in. The boiler was provided with Beattie's patent double fire-box and combustion chamber. The front portion of the barrel, 3ft. 9in. diameter, contained 248 1⁹/₁₆in. tubes with ⁹/₁₆in. clear space between them. Total heating surface, 1149 square feet; grate area, 16.1 square feet; pressure, 130 lb.; weight in working order, 33 tons. Amongst the more interesting details other than the boiler were Allan's straight link motion with reversing shaft underneath the link, and the wedge adjustments of the connecting and coupling rods. Beattie always used horizontal wedges instead of vertical cotters, fine adjustment being possible by means of a screw and nuts.

Of the coupled express engines of this period these were the only ones which may fairly be described as really successful. One of the four 1859 engines was broken up in 1887 after completing a mileage of 869,000.

Other Four-wheels Coupled Engines.—Of these, J. I. Cudworth's standard South-Eastern 2-4-0 engines—Fig. 142—were amongst the most celebrated. They originated with six engines built

³ For complete drawings of these engines see Colburn, Plates XVI and XVII.

to Cudworth's designs by E. B. Wilson and Co. in 1856-7, the design being modified in 1859 by the addition of coal-burning fire-boxes with longitudinal partitions. From 1859 until 1875 more than one hundred of the class were built with only minor modifications, chiefly in the length of the sloping fire-box. The cylinders were 16in. by 24in.; coupled wheels, 6ft.; and leading wheels, 4ft. 6in. diameter; wheel base, 14ft. 10in., equally divided. The earlier engines of 1859 had fire-boxes 7ft. 6in. long, which with midfeathers provided 140³/₄ square feet of heating surface. In later years Cudworth shortened the fire-boxes, reducing the grate area from 22.4 to 19.8 square feet and the heating surface to 113.7 square feet. The total heating surfaces of the two sizes of boiler were 950 and 938.7 square feet respectively; pressure, 120 lb. The sloping fire-box enabled the designer to place the trailing axle underneath

instead of behind it, and an excellent weight distribution resulted as follows:—

				Long fire box engines.	
				T.	C.
Leading	9	10
Driving	10	10
Trailing	10	10
				<hr/>	
				30	10
				Short fire-box engines.	
				T.	C.
Leading	9	15
Driving	10	15
Trailing	10	6
				<hr/>	
				30	16

The design of the fire-boxes will be referred to subsequently.

Scottish locomotive engineers were very partial to a large-wheeled 2-4-0 engine for main line goods traffic. Fig. 143 shows one of these designed by B. Connor for the Caledonian Railway, and built 1858-64 by Neilson & Co., Beyer, Peacock & Co., and at the company's works at St. Rollox. This design, with inclined cylinders, was a direct derivative of the old "Crewe" type, but the engines were considerably larger, having 6ft. 2in.

coupled wheels and 18in. by 24in. cylinders. Similar engines with modified boilers were constructed for the Caledonian Railway until the end of 1877.

Robert Sinclair's Eastern Counties Railway⁴ main line goods engines of 1859 by Neilson and Co.—Fig. 144—were somewhat similar but had

capacity of 135 gallons to provide an extra water supply in addition to that in the tender. The total heating surface varied from 1041 in the later to 1079 square feet in the earlier engines. Pressure, 120 lb.; weight in working order, 30 to 31 tons in the earlier engines of 1859 to 1861. The tenders had wood frames with iron horn-plates bolted on.

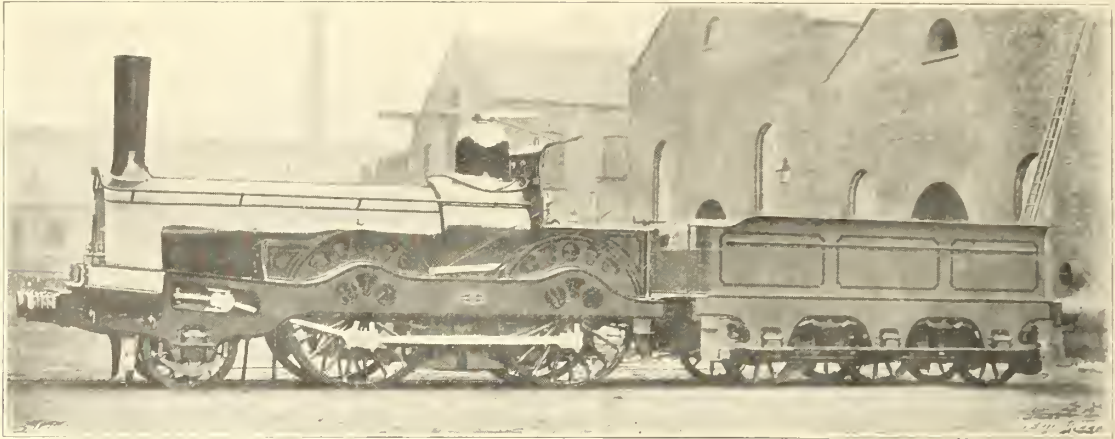

FIG. 143—E. CONNOR'S CALEDONIAN RAILWAY LOCOMOTIVE, 1858-64

horizontal cylinders, inside bearings for the leading wheels, and the Neilson type of flush fire-box casing. The coupled wheels were 6ft. 1in. diameter and the cylinders 18in. by 24in. Subsequently in 1861-66 90 more engines of the class, but with 17in. by 24in. cylinders, were built by various firms. In them the dome was placed on the middle of the boiler, and large cabs were provided. The boiler barrels were in four rings lap jointed transversely, the first and third rings being of the largest diameter. In the later engines of 1863-66 Sinclair adopted four rings of equal diameter with circumferential butt joints as in Sharp's earlier engines. Compensating levers were

Four-coupled Mineral Engines.—Several of the leading Scottish railways adopted the 0-4-2 type with outside cylinders almost exclusively for mineral traffic, and these engines were designed by such well-known engineers as Sinclair, Allan, P. Stirling, and Messrs. Neilson and Co. A typical engine by the last mentioned firm is illustrated by Fig. 145. One of Patrick Stirling's engines for the Glasgow and South-Western Railway, built by Hawthorns in 1857, is shown by Fig. 146. It was one of Stirling's earliest designs, and very unlike his later work. These engines had 5ft. coupled wheels and 16in. by 22in. cylinders.

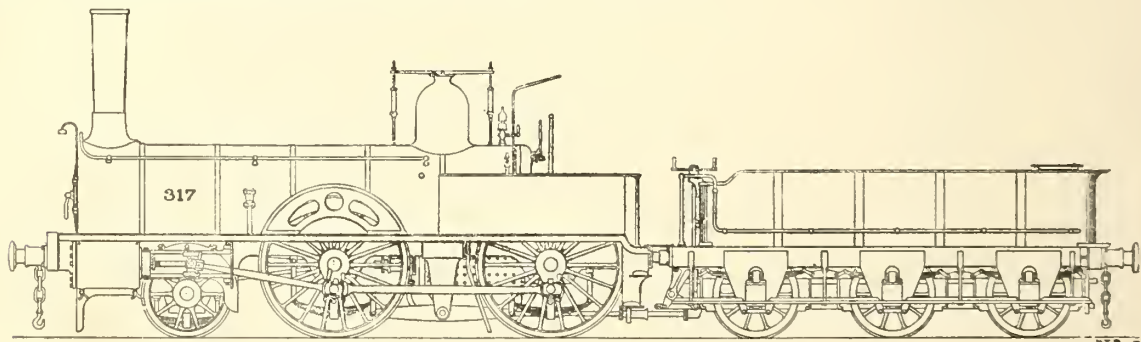

FIG. 144—R. SINCLAIR'S GOODS ENGINE FOR THE EASTERN COUNTIES RAILWAY, NEILSON & CO., 1859

provided between the coupled wheels. A cast iron footplate was added to increase the weight at the trailing end, but in those engines of the same class built by Stephenson and Hawthorn in 1861 this casting took the form of a hollow water-box of a

Bogies: General.—Till this time the bogie had made very little progress in British locomotive practice, and with the exception of the American type engines on the Birmingham and Gloucester Railway was almost entirely confined to broad—7ft.—gauge engines. Of 4-4-0 tender engines the

⁴ Clark and Colburn (1860), Plate XLI.

only example was one—possibly two—of the above-mentioned American Norris engines which had had the rear single driving wheels experimentally replaced by two coupled axles, at some



FIG. 145—NEILSON & CO.'S MINERAL ENGINE, 1861

period between 1846 and 1850. A 4-4-0 tank engine, designed and built by Stothert and Slaughter, of Bristol, was placed in service on the Monmouthshire Railway about 1850, but does not appear to have been very successful.

On the straight and comparatively well-laid British main lines, there was then very little necessity for leading bogies. The early bogies turned loosely about a fixed pivot, had no controlling arrangement, and offered such a small resisting moment that they tended to oscillate from side to side, sometimes to a dangerous extent. Their short wheel base was always considerably less than the width of the gauge, the base of the Norris engines being only 3ft. Fernihough, in October, 1845,⁵ pointed out this dangerous oscillation, and was the first to suggest that it might be damped by the frictional resistance of a bearing ring of large diameter, and that under this condition the bogie would prove useful. It was nearly twenty years afterwards that both Messrs. Stephenson and W. Adams carried out Fernihough's suggestion in a modified form.

Gooch's 4-4-0 7ft. gauge tank engines of 1849 had a bogie base of 5ft., but their turning movement was so extremely limited by the relative positions of the bearing springs, buffer beam gussets, and cylinders that the engines were hardly more flexible than if they had been of the 2-4-0 type. To assist the curving of these engines the driving wheel tires were made without flanges, so that the guidance of the engine was left entirely to the flanges of the bogie, which, unless the latter had not been an almost rigid truck, would have involved considerable danger. Pearson's 4-2-4 tank engines on the Bristol and Exeter Railway

had better bogies with a 5ft. 9in. wheel base, but even in this case the whole guidance of the engine was left to the bogies since the driving tires were flangeless.

With the notable exception of Sturrock's celebrated G.N.R. inside cylinder 4-2-2 express engine, No. 215, of 1853—Fig. 108 *ante*—the bogie of which had a base of 7ft. 2in., it does not appear to have been then understood either in this or in any other country that a bogie with a very short wheel base was not suitable for allowing the engine to place itself in the best position for traversing a curve, especially for turning the head of the engine. The leading bogie with long wheel base was the result of the accidental influence of placing outside cylinders in a horizontal position, so that, to provide room for attaching the latter to the main frames, the bogie wheels had of necessity to be spaced well apart. In the case of the latter bogie some designers omitted to allow sufficient clearance for the turning movement of the leading wheels, and neither cut out the main frames nor bent them inwards, and, in certain cases, the engines refused to stay on the rails even on moderately sharp curves. The result was either the abandonment of the bogies for a time or a return to the older design with bogie of very short wheel base placed far back as in Gooch's engines, thus shortening the distance from the rigid pivot to the centre of the trailing coupled axle. The latter form and arrangement of bogie for engines with inside cylinders disappeared when Adams in 1864 introduced the long wheel base bogie with lateral movement of the pivot controlled by check springs. A similar lateral control had previously been designed by R. Stephenson and Co. in 1861, but does not appear to have been carried out. In Adams's, and also in Cowan's 4-4-0 engines of 1865 for the Great North of Scotland Railway,

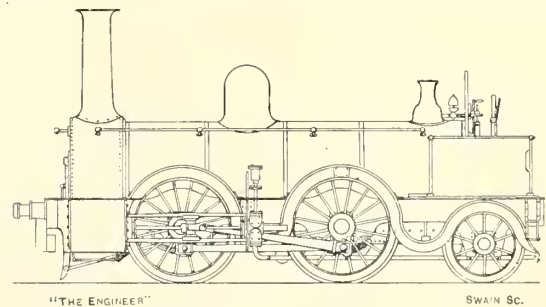

FIG. 146—P. STIRLING'S G. & S.W. RLY. ENGINE, 1857

which had rigid pivots, the frames were properly cut out to secure the necessary turning clearance.

Tank Engines, with Leading Bogies.—In 1855 five 4-4-0 side tank passenger engines—Fig. 147—were built by Messrs. Stephenson for the North London Railway. They constituted an entirely new departure, and as regards wheel arrangement were the forerunners of the later standard engines of

⁵ Evidence before Gauge Commission, Question 4873.

this railway. The cylinders (inside) were 15in. by 22in.; diameter of coupled wheels, 5ft. 3in., and of bogie wheels, 3ft.; the total wheel base was 16ft. 3in.; the coupled wheels being spaced with

In 1857 Messrs. Hawthorn built six 4-4-0 saddle tank engines for the East Kent (later, part of the London, Chatham and Dover, Railway to T. R. Crampton's design. They were noteworthy in

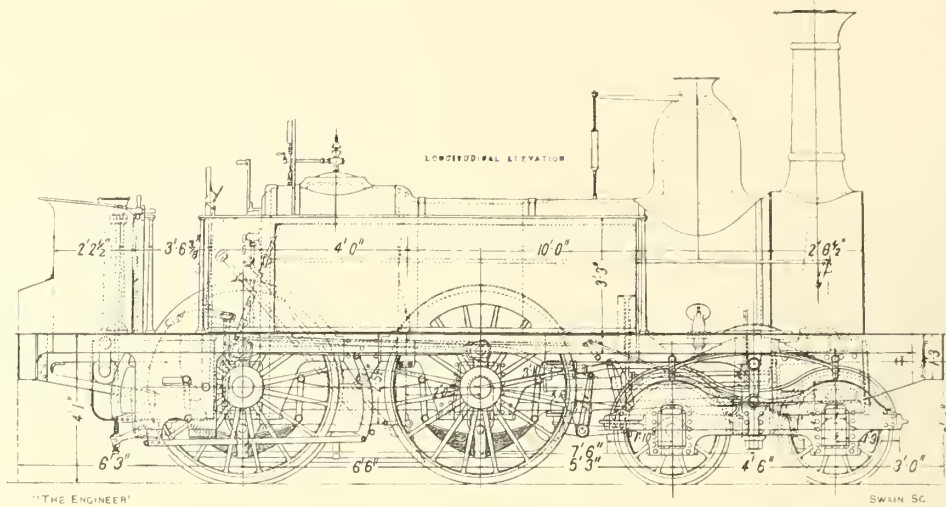

FIG. 147—R. STEPHENSON & CO'S TANK ENGINE FOR THE NORTH LONDON RAILWAY, 1855

centres 6ft. 6in. apart. The pivot was fixed and of the Gooch ball-and-socket joint type, and the bogie, like Gooch's, had a single inverted spring on each side. As the coupled wheel springs were connected by compensating levers, the engine was suspended on three points. The bogie frames and axle-boxes were outside the wheels. Its wheel base was only 4ft. 6in., and the pivot was placed behind the smoke-box. In this respect it resembled

anticipating the well-known French type of coupled engine, derived from their Crampton's, in which the outside cylinders were placed immediately in front of the first coupled axle under the middle of the boiler and the connecting-rods drove the trailing axle. The steam pipes were taken through the sides of the smoke-box. The cylinders were provided with steam jackets with internal ribs. As in many Continental designs, the whole of

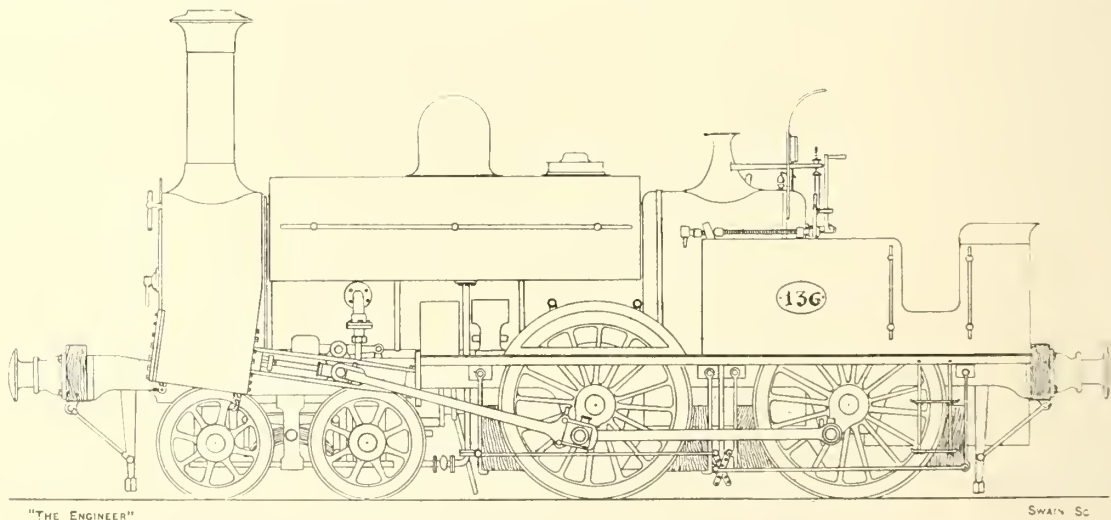

FIG. 148—J. C. CRAVEN'S L.B. & S.C. RLY. TANK ENGINE, 1859

Gooch's design, and also in that the driving wheels were without flanges, the tires being 6in. wide, those of the remaining wheels having a width of 5in. The clasp brake on the trailing wheels only was characteristic of Stephenson's tank engines at this period.

the Gooch valve gear was outside. The bogie wheel base was 4ft. in length; the cylinders were 15in. by 20in.; and the coupled wheels 5ft. 6in. diameter. In general appearance they were very similar to some tender engines which will be described later.

An experimental engine designed by J. C. Craven for the L.B. and S.C.R., and built in 1859 at Brighton works, is shown by Fig. 148. Its chief features were the steeply inclined outside cylinders, 15in. by 22in., spaced 6ft. 4½in. centre to

supported on angle iron brackets fixed on the four corners of the engine and bogie framing.⁶

Other Four-wheels Coupled Tank Engines.—Only one or two types need be mentioned. Fig. 149 shows the well-known 2-4-0 side tank engines

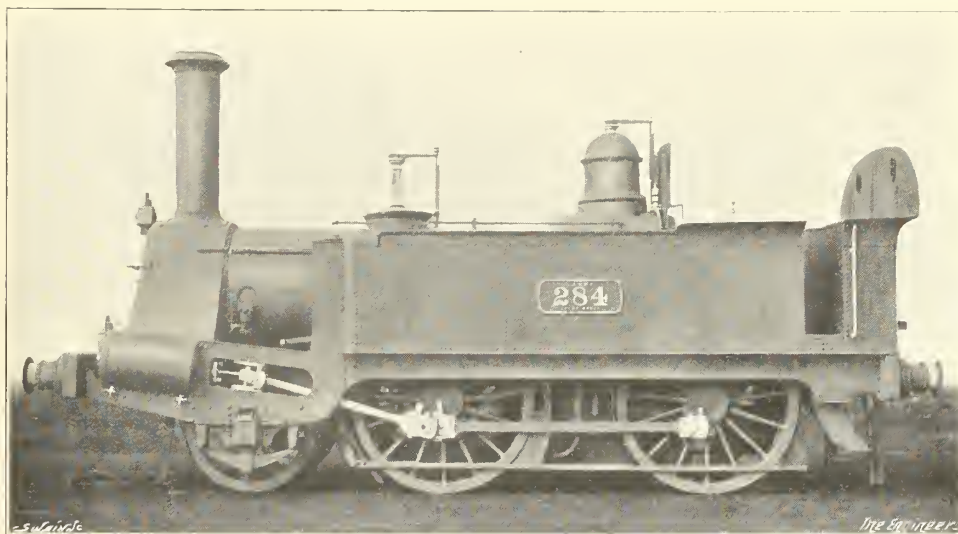

FIG. 149—F. TREVITHICK'S L. AND N.W. RLY. SIDE-TANK ENGINE, 1856

centre, and the rigid centre pin bogie placed with its leading axle under the cylinders. The coupled wheels were 5ft. and the bogie wheels were 3ft. diameter. The bogie had bar frames, and a compensating lever with single spring on each side. The bogie wheels were 4ft. apart; centre of bogie to driving axle, 8ft. 0½in.; coupled wheel centres, 6ft. 9in.; total wheel base, 16ft. 9½in. All bearings were inside. This engine worked satisfactorily, but a somewhat similar engine of 1861, in which the outside cylinders were horizontal and placed

of the L. and N.W.R., originally built by F. Trevithick, at Crewe. They were mostly conversions of the Allan type of 2-4-0 tender goods engines, though the first examples of the class built in 1856 were constructed with side tanks. The coupled wheels had a diameter of 5ft., the cylinders were mostly 15in. by 20in., and the pressure varied from 110 lb. to 120 lb. There were more than one hundred of these engines, which were ultimately employed on local traffic on all parts of the line.

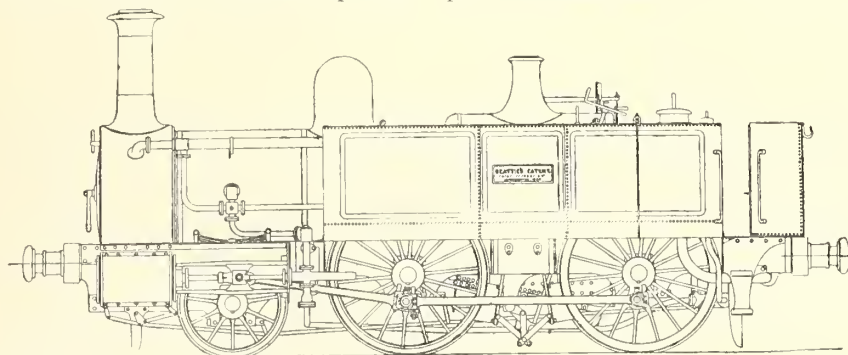

FIG. 150—BEYER, PEACOCK & CO.'S TANK ENGINE FOR THE BELFAST & COUNTY DOWN RLY., 1858

between the bogie wheels, with the wheel base extended to 19ft. 2¾in., of which the bogie base was 5ft. 11in., was a complete failure, and would not remain on the rails. This was probably due to the peculiar design, in which the body of the engine was not carried on the bogie centre, but was

Another 2-4-0 side tank passenger engine—Fig. 150—by Beyer, Peacock and Co., 1858, for the

⁶ The description of these engines is taken from "The Locomotives of the L.B. and S.C.R.," published by the Locomotive Publishing Co., Ltd. The drawing is by Mr. G. F. Burt.

Belfast and County Down Railway, had outside horizontal cylinders, 15in. by 22in., and 5ft. 6in. coupled wheels. It was provided with Beattie's patented feed-water heating apparatus. The brake

of considerably larger dimensions than the latter. The cylinders were 15in. by 24in.; the coupled wheels, 5ft. diameter; and the weight in working order was 29 tons 3 cwt. The saddle tanks



FIG. 151—W. JENKIN'S L. & Y. RLY. TANK ENGINE, 1860

[Photo. Locomotive

blocks were actuated by a form of toggle joint. This was a favourite form of brake gear with Charles Beyer, and appeared on several of Sharp's earlier tank engines, for the design of which he was responsible.

Passenger Tank Engines, with Six-wheels Coupled.—In 1856 the first six-coupled tank engines—Fig. 151—designed expressly for passenger trains were built at the Miles Platting (Manchester) works of the Lancashire and York-

extended from the front of the smoke-box to the front of the fire-box casing. The four first engines of 1856-57 were slightly different in details from the engine illustrated, which was built in 1860. The former had coupling rods of circular section, which were standard on the L. and Y.R. until the latter date.

0-6-0 Goods Engines.—During this period the standard British 0-6-0 goods engine attained the final characteristics which it has continued to hold

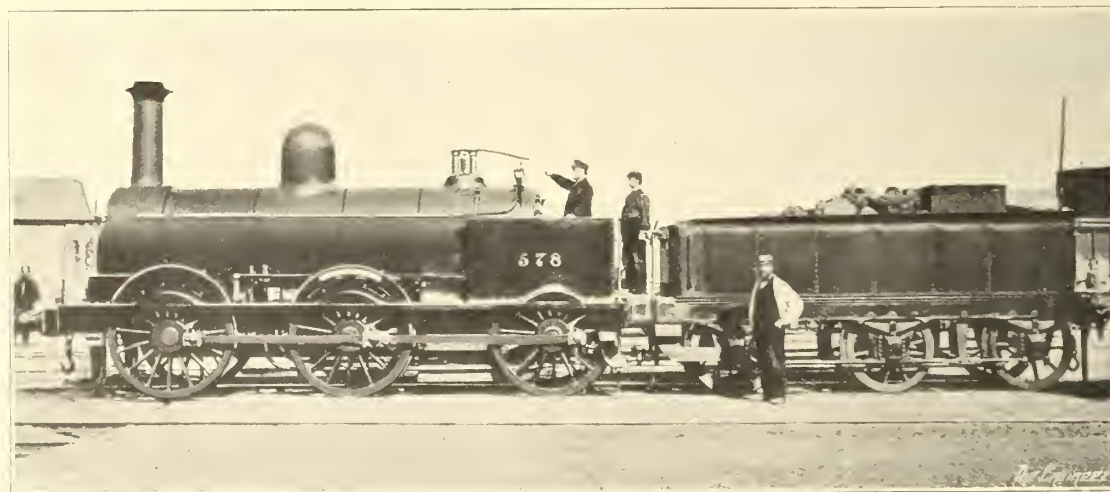

FIG. 152—JOHN RAMSBOTTOM'S L. AND N.W. RLY. GOODS ENGINE, 1858-72

[Photo. Locomotive

shire Railway for service on the severe gradients of the Oldham branches. These engines, designed by W. Jenkin, antedated Stroudley's celebrated Brighton "Terriers" by sixteen years, and were

until the present day. The modern engines are larger, and many of the latest have been provided with superheaters, but in their main features, such as the solid inside slab frames, slightly inclined

inside cylinders, etc., the design is similar to that of the old engines.

Although not the earliest, Ramsbottom's 0-6-0 D.X. standard goods engines may claim first attention. The first experimental engine of the type was built, not at Crewe, but at Longsight, Manchester, in 1858, and was laid down when Ramsbottom was superintendent there of the North-Eastern division of the L. and N.W.R. Subsequently, from September, 1858, until 1872, no less than 857 of these engines were built at Crewe for the L. and N.W.R., in addition to 86 for the Lancashire and Yorkshire Railway, which were also constructed at Crewe during 1871-74. All of these engines, 943 in number,

24in., inclined at 1 in 8; coupled wheels, 5ft. 2in. diameter; wheel base, 7ft. 3in. + 8ft. 3in. The boiler was telescopic with the largest ring at the fire-box end, and contained 192 $1\frac{1}{2}$ in. tubes; total heating surface, 1102 square feet; grate area, 15 square feet; pressure, 120 lb.; weight: leading, 9 tons 14 cwt.; driving, 10 tons; trailing, 7 tons 6 cwt.; total, 27 tons in working order.

The engines were extremely light. The tractive force per pound M.E.P. was 111.9, and, taking 85 per cent. of boiler pressure as the mean effective pressure when starting, the total tractive force was 11,410 lb., which gives a factor of adhesion of 5.3.

The inside frames were stayed longitudinally between the horns. The details presented some

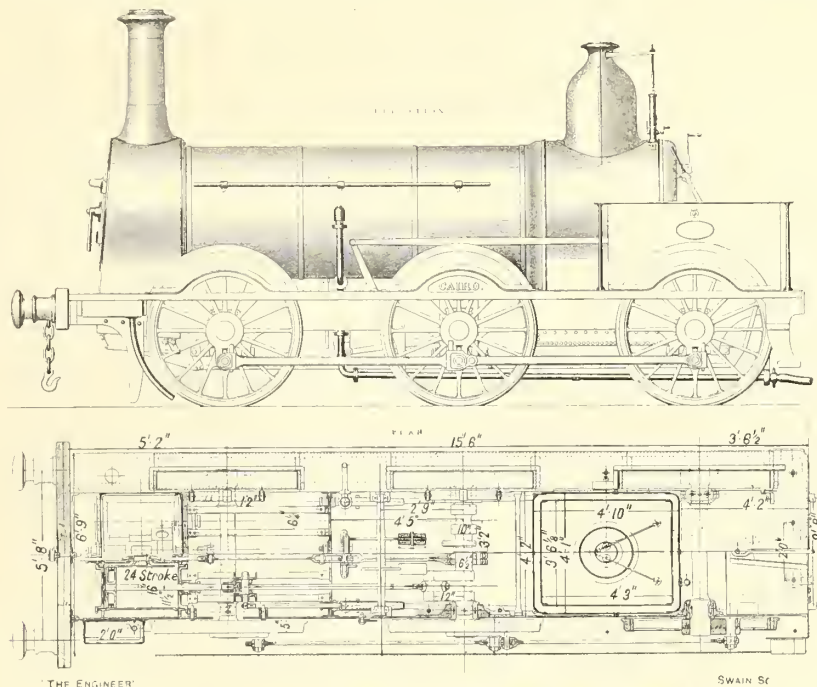

FIG. 153—BEYER, PEACOCK & CO.'S GOODS ENGINE FOR THE EGYPTIAN RAILWAYS, 1857

were identical in almost all respects, and the class presented the first example of standardisation and mass production of locomotives on such a large scale. In this connection, it should be added that similar standard work on a smaller scale had long been the practice with a few of the private locomotive building firms, notably Sharp Brothers and E. B. Wilson and Co. It is extremely probable that Ramsbottom acquired his first ideas on such standardisation from Messrs. Sharp Brothers, where he had been employed for several years before becoming N.E. divisional locomotive superintendent for the L. and N.W.R. in 1852, and subsequently for the next five years had ordered many of Sharp's standard locomotives and spare parts for use on the railway.

Fig. 152 shows one of these goods engines as originally built.⁷ The cylinders were 17in. by

⁷ For sectional elevation and plan see Colburn's "Locomotive Engineering," Plate XV.

important novelties, though whether these appeared in the earliest of the class in 1858 or were incorporated about 1860-61 the writer is unable to say. The most important of them was the screw reversing gear, which Ramsbottom brought out about 1858-59, and as far as the writer knows, he was the first locomotive engineer to use it.⁸ The regulator in the dome was of the double-beat type. The engines of 1861 and later had brick arches, which, instead of being inclined upwards from front (tube plate end) to back, were inclined downwards in the opposite direction to deflect the air which entered the fire-box through two square openings in front below the arch. No fire-door deflector appears to have been used with this arrangement. Volute springs placed above the axle-box and below the footplate were used for the

⁸ An interesting use of a wheel reverse through pinion and rack is shown by a Stephenson drawing of 1841; see Warren, page 362.

trailing axle. The motion was of the form with two slide bars and short forked connecting-rod, a design which, derived from Allan's outside cylinder engines, became standard on most L. and N.W.R. engines until 1904.

One of the best examples of the British standard goods engine, illustrated by Fig. 153, was designed by Charles Beyer, of Beyer, Peacock and Co., in 1857, and therefore antedated Ramsbottom's engine described above. Beyer's influence on locomotive design was very marked, more especially after the founding of Beyer, Peacock and Co. in 1854. Though the engine illustrated was built for the Egyptian railways, it represents a classic design, of which a number of engines with various minor modifications were built for home railways. The principal features were the plain simplicity

13½ in. at the top. Stephenson's and Sharp's chimneys were also tapered in a similar manner, as also were those of Messrs. Hawthorn, though to a smaller extent, and at a later period we also find the same principle in many of W. Stroudley's Brighton engines. Most of the other builders used parallel chimneys, and the only designer, who between 1850 and 1860 employed chimneys wider at the top than at the choke, was Robert Sinclair on the Caledonian and afterwards on the Eastern Counties Railway. The form of chimney decreasing in diameter towards the top was probably due to the old theory that the action of the jet of steam was that of a series of plugs which filled the chimney, and that as part of the steam condensed on its way up it was therefore necessary to reduce the chimney area to allow for the decrease of

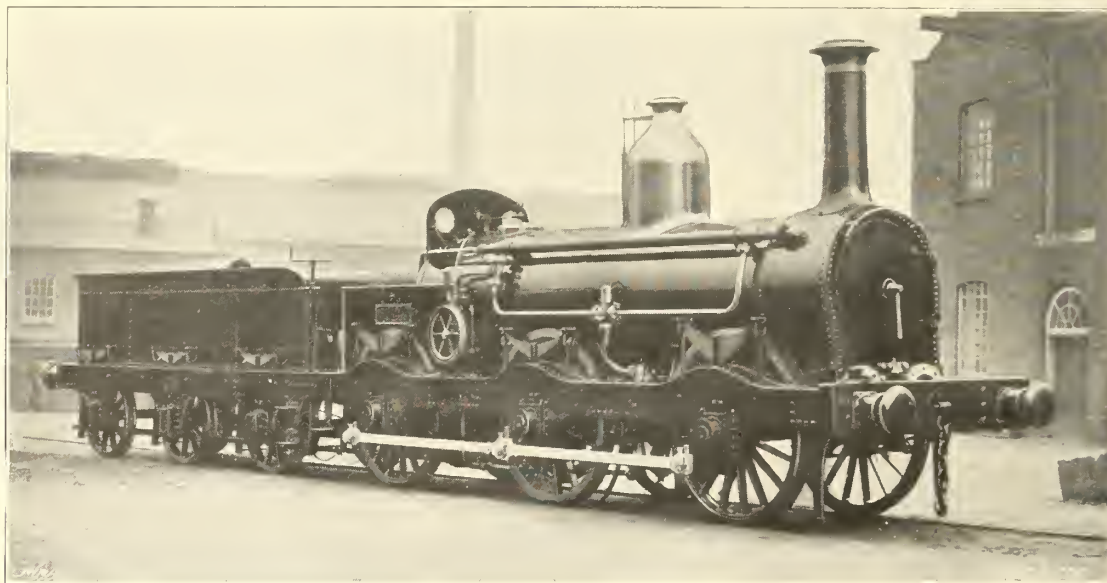

FIG. 154—BEYER, PEACOCK'S GOODS ENGINE FOR THE MIDLAND RAILWAY, 1858

of the engine and the solid deep plate frames, in which Beyer rarely employed tie bars between the horns. The hornblocks were welded solid with the frames, a form of construction to be found in some of Stephenson's early four-wheeled engines of 1832. The fire-box casing was raised, but in similar engines built from 1861 onwards it was flush with the barrel. Many of Beyer-Peacock's early engines had the dome over the casing, though the firm had no definite standard, and during the same period built designs with domes on the centre of the barrel, and also with domeless boilers. Probably the position of the dome was decided in accordance with the ideas of the railway locomotive engineers.

The taper of the chimney, which was of larger diameter at the bottom than at the top, was also another feature of Beyer-Peacock's practice for many years. In the engine illustrated the chimney was 15 in. diameter above the mouthpiece and

volume. Moreover, the fuel used before 1860 was generally coke, and the volume of smoke-box gases was less than in coal-fired locomotives. Beyer, Peacock and Co. and others had the benefit of the knowledge derived from Peacock's blast pipe experiments⁹ on the M.S. and L. Railway, as a result of which their blast pipes were placed at a level immediately above the top row of tubes, and not close to the base of the chimney as had been the practice till that time. It should, however, be noted that in the model at Paris of Stephenson's "Planet" class, built in 1833, the blast nozzle is placed near the bottom of the smoke-box and the chimney prolonged downwards in the form of a "petticoat."

The goods engine described above had 16 in. by 24 in. cylinders, 5 ft. wheels and wheel base 15 ft. 6 in., equally divided. The dimensions did not differ greatly from those of Ramsbottom's

⁹ See D. K. Clark's "Railway Machinery," pages 133-134.

engine, but the 191 tubes were 11ft. 7½in. long by 2in. external diameter, as against 192 tubes 10ft. 9in. long by 1½in. diameter in the L. and N.W.R. engine. In spite of this the fire-boxes were of practically equal length.

The double-framed goods engine was nevertheless generally preferred, and an interesting example is illustrated in Fig. 154. It was built by Beyer, Peacock and Co., in 1858, for the Midland Railway, the locomotive department of which desired to test Beattie's patented fire-box and feed-water heater, and therefore left the design of the two engines in the hands of the builders.

Both inside and outside frames extended from front to back buffer beams, and were the first examples on the Midland Railway of this improved construction. The solid deep outside frame without tie rods between the horns was characteristic of a design used by the firm for similar engines for more than forty years. A minor, nevertheless important, detail was the snapped rivet heads both in the frames and in other parts of the engine. Whenever they could be avoided

feet; of combustion chamber, 74 square feet; total, 910 square feet; grate area, 17 square feet; weight in working order, 33 tons 3 cwt. The pressure is not definitely known, but was probably 130 lb., as in other Midland engines of 1858.

One other 0-6-0 type may be briefly mentioned. Two engines were built for the Glasgow and South-Western Railway and were the first 0-6-0 locomotives designed by P. Stirling and of a type with outside cylinders very rare in British practice—Fig. 155. They were built by R. and W. Hawthorn at the end of 1855. The cylinders were 16in. by 21in.; coupled wheels, 4ft. 6in.; wheel base, 12ft. 4in., equally divided; total heating surface, 770¾ square feet, of which the small fire-box provided only 48¾ square feet; grate area, 9½ square feet. The tender was on four wheels, 3ft. diameter. The type was never repeated, and P. Stirling designed no more six-coupled engines until eleven years afterwards, by which time he had abandoned outside cylinder coupled engines and domed boilers.

Neilson's Single-cylinder Locomotive.—In 1857

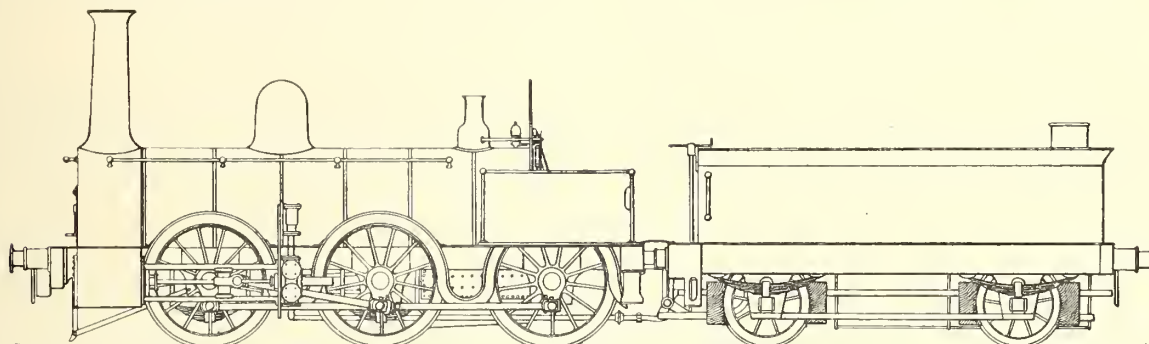

FIG. 155—P. STIRLING'S GOODS ENGINE FOR THE GLASGOW AND SOUTH-WESTERN RAILWAY, BUILT BY R. & W. HAWTHORN, 1855

Beyer, Peacock and Co. never used countersunk heads. The snapped heads were of larger diameter than those generally used, and instead of being well rounded were considerably flattened on the top. This may seem an unimportant detail, but the writer has frequently heard it stated by various district locomotive superintendents on different railways that they had rarely, if ever, known one of Beyer Peacock's rivets loose in any part of an engine. The writer can confirm this statement from one of his own experiences when he had to remove some of them which had been in the engine twenty-five years, and all had finally to be drilled out.

The cylinders were 16in. by 24in.; coupled wheels, 5ft. diameter; wheel base, 8ft. + 8ft. 3in. The boiler contained Beattie's patented fire-box and combustion chamber, to be described later. There were 396 tubes, 1¾in. outside diameter, in the front part of the barrel, the length between the tube plates of combustion chamber and smoke-box being only 5ft. 6¾in.; heating surface of tubes, 722 square feet; of fire-box, 114 square

Messrs. Neilson and Co., Glasgow, constructed a number of four-wheeled saddle tank shunting locomotives¹⁰ for colliery and ironworks railways in Scotland. They are shown in the diagram, Fig. 156, and were of unique design. A single cylinder, 10in. by 16in., was placed on the centre line of the engine below the furnace at the foot-plate end. The piston-rod, which came out at the back of the cylinder, was pinned to the centre of a transverse crosshead, to the outer ends of which the connecting-rods were attached. The latter drove the trailing wheels, 3ft. 2in. diameter, by means of outside crank pins. The trailing wheels were coupled to the leading wheels. The left-hand coupling-rod worked directly on the driving crank pin extension in the usual manner, but on the right-hand side a thin crank was interposed between the connecting and coupling-rods in such a way that the right-hand and left-hand coupling-rods were at 90 deg. This arrangement assisted the engine over dead centres, and prevented the two connecting-rods from moving the wheels in

¹⁰ W. M. Neilson's patent, April, 1856, No. 988.

opposite directions at the beginning of a stroke. The fire-box consisted of a \square -shaped furnace, 3ft. 8in. long, with flat top stayed with transverse girders, and between the furnace and smoke-box tube-plates were 74 tubes, 5ft. long. Steam was taken from a dome at the back of the boiler to a valve at the side of the footplate, which served as a regulator, and thence passed downwards to a steam chest on the left-hand side of the cylinder. The reversing gear consisted of two eccentrics, one at each end of the leading axle, with short rods terminating in gab forks, to which a transverse shaft was attached by lifting links. The valve spindle came out at the back of the cylinder, where it was attached to a short "crosshead." To the outer ends of this crosshead two long valve rods, which passed one on each side of the cylinder to the cross shaft, were connected.

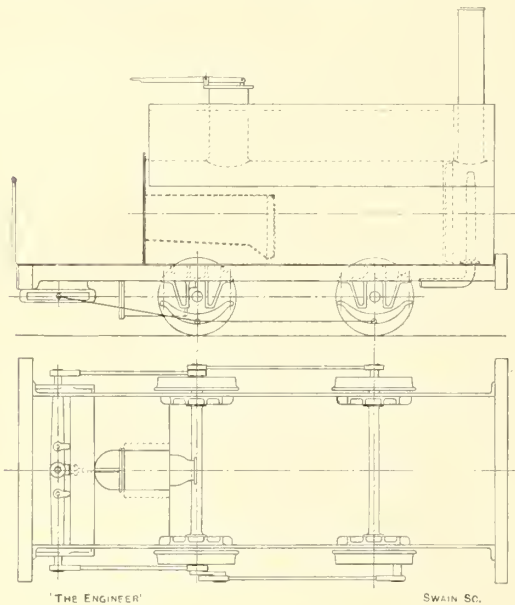

FIG. 156—NEILSON'S SINGLE CYLINDER ENGINE, 1857

DETAILS.

In 1855 *Beattie's Feed-water Heating Apparatus* came into use on the London and South-Western Railway. It went through various modifications, and was fully described in *The Engineer*, March 16th, 1923, page 280, and in the "Locomotive Superheating and Feed-water Heating" supplement of the *Locomotive Railway Carriage and Wagon Review*, pages 77 to 79. It is interesting to note that the system of taking about 15 per cent. of the exhaust steam from the blast pipe and condensing it in the tender or in other special apparatus employed, does not appear to have affected the back pressure in the cylinders, either by increasing or decreasing it. A series of trials by Bauschinger with similar German condensing feed-water heating apparatus showed a similar result. The friction in the long pipes appears to have offset any theoretical advantage due to con-

densing. Beattie's system, which undoubtedly showed considerable thermal economy, was tried on several British railways, but, except on the L. and S.W.R., was abandoned after a short time, partly on account of the complication and expense of upkeep, but probably chiefly owing to the introduction of injectors in 1859-60.

Cast Iron Fire-bars may have been used at a very early period, but their more extended application dates from about 1856-58 in connection with coal fuel.

Stays.—In 1855 David Joy on the Oxford, Worcester and Wolverhampton Railway, owing to fire-box stay troubles due to bad water, drilled the ends of the stays with "detector" holes, $\frac{1}{8}$ in. diameter, to give warning of the impending breakage of the stay.

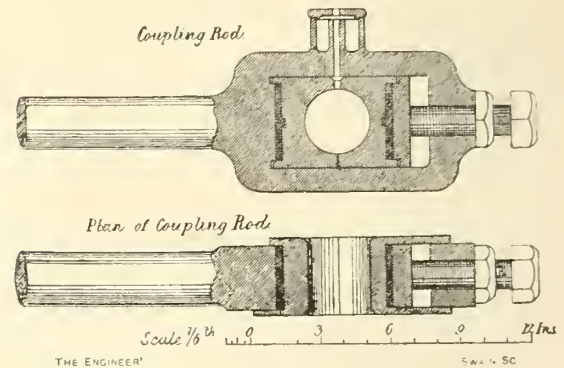

FIG. 157—FAIRBAIRN'S COUPLING ROD

Coupling Rods.—The form of coupling rod used by J. Beattie on the L. and S.W.R. from 1859 and for many years later is shown in Fig. 158. The usual vertical cotters were replaced by horizontal wedges with a fine screw adjustment, which enabled the brasses to be taken up without hammering down the cotters too tightly. A peculiar design of coupling-rod end was applied by W. Fairbairn and Sons to some tank engines built in 1855, and is shown in Fig. 157. Elastic india-rubber cushions were placed between the ends of the brasses and the iron body of the rod end to allow for careless adjustment of the length by fitters and drivers. The arrangement does not appear to have had much, if any, further application.

Axle-boxes, Wheels, Tires, Etc.—The axle-box—Fig. 159—was designed by Messrs. Fairbairn for end carrying axles to provide a lateral controlling force tending to restore the box to its central position by means of round india-rubber washers, when leaving a curve. The angle-box A did not bear directly against the horncheeks B. Interposed between them were the side pieces D, with double inclined planes, and between the latter and the channel-shaped horncheeks B, three rubber washers C were placed on each side. The restoring force was exerted by the effort of the latter to resist compression. This appears to have been one

of the earliest forms of axle-box with controlled side play and a small angular movement, but like the coupling-rod does not appear to have had more than a few experimental applications.

At about the same time, Bissell trucks were patented in this country in May, 1857, though their earliest application to a British-built engine—for abroad—was not made until about three years afterwards.

A form of compensating lever for double-framed engines was applied by Kitson and Co., in order to connect the springs of one carrying and two driving bearings on each side. The arrangement is shown by Fig. 160. The lever was inclined, one end being connected to the spring pin of the carrying bearing, and the other to a long spring pin common to the inside and outside springs of the driving axle.

Tires were of wrought iron welded in some cases with steeled-faces. According to W. P. Marshall,¹⁰ solid steel weldless tires were manufactured by Krupp in 1851, but when they were first used in this country is uncertain. Beattie's iron tires of 1859 were made with a lip on the outside—Fig. 161—to prevent the tire from coming off. A stud was inserted between each pair of spokes.

Valve Gears and Motion.—In 1856 Alex. Allan's straight link motion was first applied to two 0-4-2 goods engines on the Scottish Central Railway, of which the inventor was then locomotive superintendent. The gear, which was extensively used, is so well known as to require no further mention. It has not been applied to any new engines in this country for more than twenty-five years, but a considerable number of L. and N.W.R. engines, built from 1874 to 1897, were fitted with it, and many are still in service.

In most of the engines with Stephenson's link motion the valve rods were jointed and suspended by swing links from a small bracket attached to the bottom of the boiler, and in later and improved designs this bracket was fastened to the top of the motion plate. This was a good arrangement, in that it enabled the designer to obtain long excentric rods, since the expansion link could be placed well in front of the motion plate. This motion, in the case of the 16in. and 17in. engines of the 1855-80 period, always gave good results. Some engineers objected to the wear of the pins at the valve-rod joints, and Ramsbottom was one of the first to modify this design. In his D.X. goods engines of 1858 the valve-rods worked in a guide attached to the slide bars. The arrangement was different from that usually seen in that the valve-rods were of rectangular section, and both worked together in a single rectangular guide. Since their inner sides rubbed against each other, rubbing plates of brass were let into these sides.

This motion was adopted at a later date on the Great Western Railway. Whether it had any advantages over the usual designs is very doubtful. It certainly had the disadvantage of shortening the excentric rods. Matthew Kirtley in the Midland engines of 1857 and later, used a gun-metal valve-rod guide, bolted on the top slide bars, instead of to the motion plate, and in this

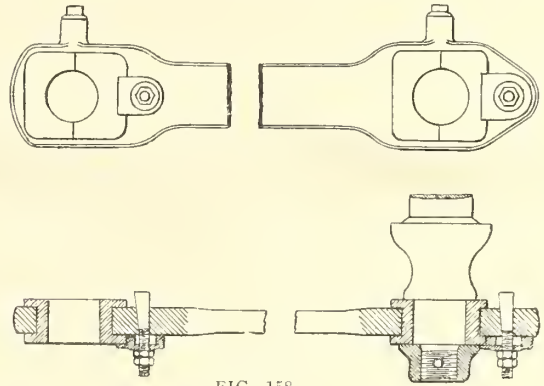

FIG. 158

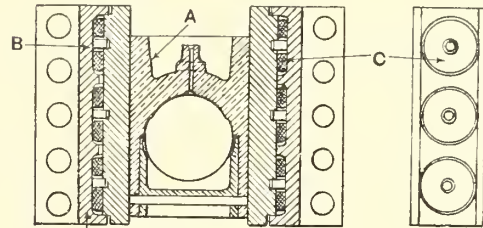

FIG. 159

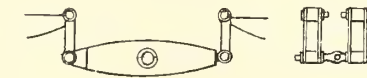
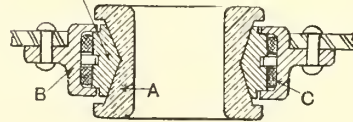

FIG. 161

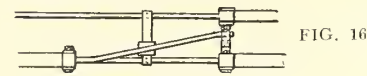

FIG. 160

"THE ENGINEER"

FIGS. 158 TO 161

way obtained the advantage of long excentric rods. Each valve-rod worked in a separate circular hole in the guide in the usual manner. This motion can be seen on nearly all the Midland 2-4-0 engines, on which it was used until 1881. It was illustrated in a drawing of a Midland goods engine—*The Engineer*, Supplement, June 7th, 1872.

¹⁰ "Proc." Inst. C.E., 1898

Chapter X—Locomotive Performances, 1845-59

FROM the opening of the Liverpool and Manchester Railway in 1830 until the end of 1845, there were plenty of records by Pambour, Whishaw, and in the Gauge Commission evidence, from which speeds and performances could be analysed. These have already been briefly mentioned. Subsequently a certain amount of similar information covering the period 1845 to 1853 is also available, derived principally from experimental trials, some of which were stimulated by the gauge controversy. Much of it was recorded by D. K. Clark in "Railway Machinery." But during the period from 1853 until about 1876 there is hardly any information whatever. Very few experiments appear to have been made, and these, with the exception of coal-burning trials, mostly with goods engines, were not at the time considered of sufficient interest for publication. The greatest void is the absence of authentic speed records of express trains of known weights. No train-timing enthusiast, such as the late C. Rous-Marten, appears to have existed, and the very few records which found their way into print appeared in the daily Press and were mostly either inaccurate or mythical.

G.W.R. Broad Gauge.—In August, 1847, trials were made with the eight-wheeled 8ft. single engines—"Great Britain" class—with 18in. by 24in. cylinders, from Paddington to Swindon and back—154½ miles. Weight of engine and tender, 50 tons.

	"Great Britain."	"Iron Duke."
Average speed for six double journeys, miles per hour	51	53.4
Average speed for best double journey, miles per hour	54.5	56.7
Gross average load, engine, tender and train, tons	103.5	105
Coke per mile, average, lb.	34.4	36.6
Total water per pound of coke, lb.	8.23	8.4
Temperature of water in tender, deg.	109	91
Coke fired per square foot of grate per hour, lb.	83.6	93.1

The rate of firing was not given by D. K. Clark, but has been calculated by the writer from the available data. The total water per pound of coke does not represent the equivalent evaporations from and at 212 deg. Unfortunately, the actual boiler pressures were not stated, but on the basis of a working pressure of 100 lb., these equivalent evaporations would be:—"Great Britain," 9.4, and "Iron Duke," 9.9 lb. per pound of coke.

One of the first things likely to occur to the modern observer is the heavy coke consumption per mile on a very easy road as regards curves and gradients with light trains weighing 53½ to 55 tons behind the tender. As a result of experiments on other railways Clark—"Railway Machinery," page 316—stated that "with equal weights of

coke and coal, coke is capable of evaporating 50 per cent. more water than coal, their mechanical values being in the ratio of 2 to 3."¹ Based on these figures the coke consumption of the Great Western engines was equivalent to rates of 51.6 lb. to 54.9 lb. of coal per mile with exceedingly light trains. These figures are manifestly absurd. The 2:3 ratio appears to have been derived as a result of early coal-burning trials, either with fuel of poor quality or in small coke-burning fire-boxes unsuitable for coal. In the early attempts at coal burning the hydrocarbons were not properly consumed, and coated the inside surfaces of the tubes with soot, a bad conductor of heat. This may partly account for Clark's ratio. Further, Edward Woods stated² that in the trials with McConnell's engines, the Hawkesbury coal used contained only 67 per cent. of carbon, whilst the coke contained 94 to 96 per cent.

M. Perdonnet ("Chemins der Fer," 1865) pointed out that on the Eastern Railway of France the weight of coal compared with that of coke consumed in the same fire-boxes was in the ratio of 14 to 10, which is not far from Clark's figure, but he added that the coal burnt was very impure and that the coke had been produced from washed coal.

The writer travelled a great deal on the foot-plates of the G.W.R. 8ft. single engines between London and Newton Abbot, a few years before the abolition of the broad gauge, when the Welsh coal consumption was about 28 lb. to 32 lb. per mile with average train loads of 120 to 130 tons, or about double the weight of those in the 1847 experiments. The general dimensions of the later engines differed only slightly from those of the 1848 period, but the boiler pressure was higher.

One reason given for the high coke consumption of 1848 was that the grates and fire-boxes were too large for coke burning. Clark stated that in subsequent trials in 1849 with similar engines, six of the "Great Britain" or "Iron Duke" class, with 21 square feet grate area, 142 square feet fire-box, and 1769 square feet total heating surface, evaporated 7.69 lb. of water per pound of coke, whereas seven of the similar "Courier" class, but with 23.6 square feet of grate area, 149¾ square feet of fire-box, and 1739¾ square feet of total heating surface, evaporated only 7.19 lb. of water per pound of coke, the average loads and speeds being practically the same as those in the earlier trials. These heating surfaces are those given by D. K. Clark, who in nearly all cases estimated them on the "fire-side." The

¹ See also "Railway Machinery," page 123.

² "Proc." Inst. C.E., Vol. XVI, Discussion on D. K. Clark's paper "On the improvement of Railway Locomotive Stock."

actual water-side surfaces were:—"Iron Duke" class, fire-box 147.87, total 1945 square feet; "Courier" class, fire-box 162, total 1919 square feet. The fire-boxes had transverse midfeathers. The figures 7.69 lb. and 7.19 lb. for "evaporation" were the amounts of water actually used. As subsequently given by the same author, they were 9.17 lb. and 8.6 lb. respectively, from and at 212 deg. The coke burnt per square foot of grate per hour was 90 lb. for the "Great Britain" class and 75 lb. for the "Courier" class. The maximum boiler pressure at the time of the trials was 100 lb., but was subsequently raised to 115 lb. or 120 lb. The blast pipe orifice, which was placed only 2 in. below the crown of the smoke-box, was stated by Clark³ to have been 5½ in. diameter. This was Tredgold's outside measurement, and the actual orifice during some of the trials was 5 in.⁴

Though with thick coke fires a gas producer action would occur and loss might result from the formation and escape of CO, it is hard to believe that this action took place in the case of the G.W.R. engines with their extremely large grates, unless the transverse partition tempted the fireman to maintain too thick a fire in the back compartment of the fire-box. This was certainly one of the defects of such partitions, which in these G.W.R. engines were so high that it was hardly possible to fire the front compartment properly. Clark pointed out that these engines had too many tubes packed together with but ½ in. clearance, and that this was one of the causes of the inferior evaporative results. There were 303 2 in. tubes in a barrel 4 ft. 7¼ in. inside the smallest ring. In the reconstructed engines of 1870 to 1876 the tubes were reduced to 1½ in. diameter, and in some cases to 1¼ in., but 369 to 377 of them were contained in a barrel of practically the same diameter. The transverse fire-box partitions were discarded, and the boiler pressure was raised to 140 lb. The spaces between the fire-bars, which in the old coke-burning engines had been 1¾ in., were reduced to about ¾ in. in the coal-burning type. These are the engines of which the actual coal consumption in later years is referred to above, and, of course, the increased pressure must be taken into consideration when making comparisons.

The broad-gauge 8 ft. single engines from 1847 until about 1880 undoubtedly performed the fastest running in the country. In 1848 the 9.50 a.m. from Paddington arrived at Swindon (77¼ miles) in 85 min. with an intermediate stop at Didcot, and the run from the start to the latter station, then 53 miles, must have been performed in 56 min. if time were kept. In this connection there was a story current for many years that the "Great Britain" had on May 11th, 1848, covered the 53 miles in 47½ min., start to stop, the average speed being 66.9 miles per hour. It is just within

the bounds of possibility that this may have been done with one of the very light trains of those days, but there is no authentic confirmation⁵ of the performance, which was never repeated. What makes it somewhat doubtful is the softness of the iron rails of those days, and the low moment of inertia of the light rail sections, in addition to which the effect of an almost continuous, though very slight, rising gradient has to be taken into consideration.

Charles Sacré, afterwards chief locomotive engineer of the M.S. and L. Railway, was present at the trials in 1847-49 of the 8 ft. singles, and many years afterwards told C. Rous-Marten that the maximum speed which could be obtained down the Wootton-Bassett bank of 1 in 100 was just over 78 miles per hour. Pearson's Bristol and Exeter 9 ft. double-bogie tank engines are stated to have attained 81.8 miles per hour down the Wellington bank of 1 in 81. If this latter speed was actually attained it probably remained a record for more than thirty years.

Standard-gauge Engines.—In May, 1848, the Midland Railway made a trial between two standard 2-2-2 engines, one a "Jenny Lind," by E. B. Wilson and Co., and the other one of Sharp Bros.' engines.⁶ Each engine ran a train consisting of nine carriages and two vans from Derby to Masborough. Both engines were almost new and the test was made to ascertain which was the better for fast trains.

The line rises to Clay Cross (20 miles) at an average gradient of about 1 in 330 and then falls similarly for the remaining 20 miles. Therefore, comparing the figures with those of the Great Western "Iron Duke" and "Courier" classes, the "Jenny Linds" show better results, for not only was the road harder, but the trains were heavier, though the gross loads were almost the same. The coke consumptions are, as in the case of the G.W. engines, high, but it would seem that the trials were somewhat in the nature of a race to see which engine could "get there first," and probably more coke was burnt than would otherwise have been the case.

In these engines the fire-boxes and grates were of very moderate dimensions, and the high coke consumption appears to have been due to the forcing of the boilers, and much unburnt carbon monoxide, and probably coke also, must have been pulled through the tubes. The Wilson engine with 11 ft. tubes evaporated more water per pound of coke than the Sharp engine with 10 ft. tubes. In a second trial with heavier loads of seventeen carriages, weighing 99.8 tons behind the tenders,

⁵ Nearly forty years afterwards the writer often talked to the fireman of the "Great Britain" during this run, who always maintained that it had been done as recorded, but as he was sixty-five to seventy years of age when the conversations took place, his evidence is of doubtful value.

⁶ These trials are not mentioned by D. K. Clark, but he gives other comparative trials between similar engines on the M.S. and L.R. at considerably lower speeds ("Railway Machinery," page 314).

³ "Railway Machinery," page 130.

⁴ Tredgold's "Steam Engine," 1852 edition, Table XIII, page 61.

the respective quantities of water used were approximately $7\frac{1}{2}$ lb. and 6 lb. per pound of coke.

As regards loads and speeds combined, these performances were certainly the best on record of that day. With a net load of 100 tons the Wilson engine passed the eighteenth milepost from the dead start in 26 min. 19 secs., and the Sharp engine in 27 min. 55 sec., the gradient being uphill the whole way. The superiority of the Wilson engine was almost entirely due to the much higher pressure—120 lb. per square inch.

The following are the published figures, to which the writer has added the data marked †:—

	Wilson's "Jenny Lind."	Sharp's Engine.
Cylinders	15in. by 20in.	16in. by 20in.
Diameter of driving wheels ...	6ft.	5ft. 6in.
Boiler tubes	124	161
	2in. by 11ft.	2in. by 10ft.
Heating surface—Tubes ...	720 sq. ft.	847 sq. ft.
Fire-box	80 "	72 "
Total	800 "	919 "
Working pressure	120 lb.	80 lb.
Weight of engine, loaded ...	24 t. 1 c.	21 t. 9 c.
Weight of tender, loaded ...	15 t. 13 c.	12 t. 11 c.
Weight, total, loaded ...	39 t. 14 c.	34 t. 0 c.
†Tractive force per lb., m.e.p. ...	62.5 lb.	77.58 lb.
†Tractive force at 65 per cent. boiler pressure	4876 lb.	4034 lb.
†Tractive force at 35 per cent. boiler pressure	2625 lb.	2172 lb.
†Weight on driving wheels ...	10 tons	9.1 tons
Weight of train	64 tons	64 tons
Gross weight, engine, tender and train	103 t. 14 c.	98 tons
Time from start to stop ...	46 m. 32 s.	50 m. 10 s.
†Average speed throughout ...	51.9 m.p.h.	48.1 m.p.h.
Maximum speed	59 m.p.h.	58.5 m.p.h.
Coke consumption	13 cwt.	16 cwt.
Coke per mile	36.2 lb.	44.5 lb.
†Coke per gross ton-mile35 lb.	.45 lb.
†Coke per net ton-mile56 lb.	.69 lb.

The coke consumptions were given only to the nearest hundredweight, and therefore all figures involving them can only be approximate.

In February, 1848, a very light special newspaper express from London (Euston) to the North was worked by Midland engines of the above-named classes. From Rugby to Derby the Sharp engine ran through at an average speed of 52.5 miles per hour. A Wilson "Jenny Lind" took the train on from Derby to Altofts Junction, north of Normanton, $63\frac{3}{8}$ miles, in 68 min., the average speed being 56.1 miles per hour. This train was arranged by W. H. Smith and Son to convey copies of *The Times* containing Lord John Russell's Budget speech of February 18th, 1848, from London to Glasgow. Leaving Euston at 5.35 a.m. on the 19th, it reached Wolverton, $52\frac{3}{8}$ miles, in exactly one hour, and from Wolverton to Rugby the average speed was 51.4 miles per hour. The writer does not know what type of L. and N.W.R. engine was used, but in all probability it was one of the long boiler Stephenson rear-driver single engines, as these were the only express engines then available (Fig. 58). On the lines north of Normanton (Altofts Junction), afterwards the N.E.R., the

average speed was about 50 miles per hour. The train reached Glasgow, *via* Newcastle and Edinburgh, in 10 h. 22 min., the net *running* time for the $470\frac{3}{4}$ miles being 9 h. 32 min.⁷

In April, 1847, Stephenson's three-cylinder engine, at that time of the long boiler type with rear driving wheels, was tried on the L. and N.W.R. and worked a special express weighing about 30 tons from Wolverton to Birmingham. The run from Wolverton to Coventry, $41\frac{1}{2}$ miles, was stated to have been performed in 42 min.⁸ This engine was sold to the York, Newcastle and Berwick Railway, and W. W. Tomlinson⁹ records that it "took the Royal train from Berwick to Newcastle at an average speed (excluding a stoppage of 5 minutes) of 57 miles per hour. The writer is inclined to believe that some error in this figure occurred at some time or other, since the objection of H.M. the late Queen Victoria to high speeds was well known.

Some particulars of an early run in August, 1845, of a light special express from Sunderland to London (Euston) *via* Derby and Rugby were given in *The Engineer* of September 1st, 1905.

Of the performances of the L. and N.W.R. engines, including McConnell's "Bloomers" (7ft.) and 300 class (7ft. 6in.), the latter with combustion chamber, as well as the small Allan type Crewe engines, a very full record is given in the exhaustive report of Edward Woods and H. P. Marshall as a result of experiments made by them during February and March, 1853. The most important particulars were fully summarised by D. K. Clark ("Railway Machinery," pages 314-316) and are too long for detailed analysis here. Suffice it to say that in the trials between the 7ft. "Bloomer" No. 291 and the "Crewe" engines the following average results were obtained from the first five experiments, in which only these two classes were concerned:—

	7ft. McConnell "Bloomer" No. 291.	6ft. Crewe engine, "Heron" class.
Mean net train load (seventeen carriages), tons	86	86
Mean gross load, including engine and tender, tons	132	115
Mean speed, miles per hour ...	34.27	33.67
Mean maximum speed, miles per hour	50	45.4
Coke per ton-mile of train load only, lb.357	.344
Water evaporated per pound of coke, lb.	6.75	7.54
Coke per mile, lb.	28.08	27.13

No. 291 had 16in. by 22in. cylinders and those of the "Crewe" engines were 15in. by 20in.

One important point is not mentioned, and appears to require explanation. McConnell's

⁷ There were delays at Newcastle and Berwick in conveying the papers across the rivers, as the High Level and Border Bridges were not then opened. Full details of this run appeared in *THE ENGINEER*, July 6th, 1900, page 16.

⁸ *THE TIMES*, April 29th, 1847; the *RAILWAY CHRONICLE*, May 8th and 15th, 1847.

⁹ "The North-Eastern Railway: its Rise and Development," page 539.

engines were constructed to work at 150 lb. boiler pressure. During the trials they were pressed at 120 lb. and 130 lb. to correspond with the pressures carried by the "Crewe" engines. This fact appears to the writer to vitiate comparison between the engines as actually designed and intended for service.

In all the cases previously mentioned the coke consumption was probably greater than the average, for D. K. Clark gives instances in regular practice in which the coke consumption was 18 lb. to 25 lb. per mile, and in some trials of J. V. Gooch's main line tank engines on the Eastern Counties Railway it was as low as 15 lb. to 15½ lb., with trains of 45½ to 68 tons at a mean speed of 38 miles per hour.

When coke-burning boilers were "forced" the long boiler appeared to advantage. "The method of extending the heating surface by increase of length, whether in the fire-box or tubes, but especially in the latter, is consistent with the soundest practice, and Stephenson's long boiler was in all respects a decided advance upon previously existing examples."¹⁰

COAL BURNING IN LOCOMOTIVES.

Locomotive Fuel, 1825 to 1850.—The early Stockton and Darlington engines were coal burners. This fuel was cheap and obtainable from the collieries served by the railway. The large furnace volume of the flues, more especially in the case of the return-flue boilers, materially assisted the process of combustion. The areas of the flues were large and the velocity of the gases comparatively slow, so that time was allowed for the gases and air to become mixed. The evaporation *per square foot of heating surface* was considerably higher than that of the later multitubular boilers. Much of the smoke was consumed, though a considerable amount must have been emitted, since we find a clause in the Act for the Liverpool and Manchester Railway which prohibited the emission of smoke. In 1828 George Stephenson was experimenting with the "Lancashire Witch" and "Twin Sisters" locomotives to solve the problem of coke burning. Although coal was not prohibited, the result of the Act was that from 1829 coke for many years became the universal fuel on main line railways other than the Stockton and Darlington and one or two other lines in the Durham area.

The early multitubular boilers with their small fire-boxes and grates and short tubes were unsuitable for bituminous coal burning, in that there was insufficient grate area and fire-box volume and inadequate time for proper combustion. The early experimental attempts to overcome these difficulties took the forms of (1) providing special means for increasing the air supply above the fuel, (2) the addition of some form of combustion chamber between the fire-box and the tubes, and (3) increasing the length of path of the gases

inside the fire-box by means of complicated bridges, generally in the form of water "pockets," which deflected the gases downwards on to the fire before they entered the tubes. This last method added a certain amount of heating surface, of doubtful value, but was detrimental in that the space occupied reduced the fire-box volume, thereby increasing the velocity of the gases and consequently decreasing the time for combustion. It is unnecessary to describe most of these systems in detail; many of them were illustrated in Clark and Colburn's "Recent Practice in the Locomotive Engine" (1860), beginning with Gray and Chanter's early fire-boxes of 1837-39 and ending with Alexander Allan's and D. K. Clark's systems of 1857-58. With the exception of Clark's most of them were characterised by extreme complication and a multiplicity of awkward joints, which, whatever the merits of the systems as efficient coal burners, ultimately condemned them on account of heavy fire-box repairs.

In one of Chanter's fire-boxes, not described in the work mentioned above, there were three vertical brick partitions between which the gases and air passed on their way to the tubes.¹¹ But the most interesting feature of this design, which was tried in 1841 or 1842 between Birmingham and Derby, was the use of transverse water tubes extending from side to side in the fire-box and supporting the brick partitions. In this we have what is probably the first example of *fire-box* water tubes above the grate.¹²

Hall's System.—The earliest arrangement which appears to have been successful in consuming smoke was that of Samuel Hall, of Nottingham. It was applied to a small four-wheeled engine "Bee" on the Midland Counties Railway in 1841. It was originally entirely an air admission system, in which sixteen of the lower boiler tubes were prolonged to the outside of the smoke-box door, where they were bell-mouthed to catch air which was conveyed through the boiler to the fire-box. Eight additional air tubes were inserted through the sides of the casing and fire-box. A steam jet or blower was provided in the chimney for use when the engine was standing. A brick arch was also fixed in the fire-box,¹³ though this seems to have been a subsequent addition after the engine had been working a short time. The blower may be considered to have been an adaptation of Nicholson's steam jet of 1806, but the brick arch for deflecting the gases appears to have been entirely new. The plan was abandoned, chiefly owing to the smoke-box becoming red hot. With its disappearance loco-

¹¹ "Proc." Inst. Mech. E., 1860; Markham on "Coal Burning in Locomotives."

¹² A water tube grate was used on Stephenson's S. and D.R. "Experiment" of 1826 or 1827—see Warren, pages 120 and 133. T. Hackworth's "Globe" of 1830 had transverse water tubes in the flue, somewhat similar in principle to those of Galloway's later stationary boilers.

¹³ Markham, "Proc." Inst. Mech. E., 1860.

¹⁰ D. K. Clark's "Combustion of Coke in Locomotive Fire-boxes," "Proc." Inst. C.E., Vol. XII, 1853.

motive engineers lost sight of the value of the brick arch for about fifteen years. Hall's system seems to have cropped up from time to time in later years. D. K. Clark wrongly ascribed it to Edward Wilson on the Oxford, Worcester and Wolverhampton Railway in 1858.¹⁴

Hall appears to have been the first originator of the idea of the brick arch, though the late Mr. Bowen Cooke¹⁵ ascribed it to a driver on the London and Birmingham Railway, who built a block of bricks in the fire-box as a sort of heat reservoir. This was a failure, and the block was converted into an arch by removing the middle portion. The date was not mentioned, but was probably later than Hall's arrangement.

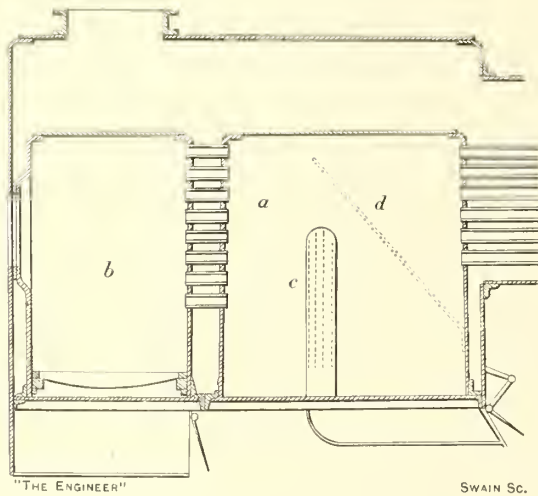

FIG. 162—DEWRANCE'S FIRE-BOX. 1845

Dewrance's Double Fire-box.—In 1845 the Liverpool and Manchester engine "Condor" was constructed to John Dewrance's design with the double fire-box shown in Fig. 162.¹⁶ The back box with the grate bars was the fire-box proper and was connected with the front box or combustion chamber *a* by a series of tubes. This was the first system in which the value of fire-box volume for coal burning appears to have been recognised. Air was admitted from a front damper through a series of vertical perforated tubes *c* in the combustion chamber, which was otherwise air-tight at the bottom. A subsequent addition of an inclined deflector plate *d* was made to increase the length of the path of the gases. The engine was stated to have performed satisfactorily as regards coal burning, but the use of the system was never extended.

Air Inducing Steam Jets.—In 1845 Messrs. Hawthorn supplied an engine to the Eastern Counties Railway, in which a series of steam jets

¹⁴ Clark and Colburn, "Recent Practice in the Locomotive Engine," page 30, and Colburn's "Locomotive Engineering," page 296.

¹⁵ "Proc." Inst. Mech. E., March, 1908, page 350.

¹⁶ From Clark and Colburn's "Recent Practice in the Locomotive Engine."

near the fire-door injected air, which was brought through a pipe. The steam and air were blown downwards on to the surface of the fire, and a second row of steam jets placed along the top of the fire-box tube plate deflected the smoke and gases downwards before they entered the tubes. The idea was subsequently developed by D. K. Clark.

J. E. McConnell's Boiler.—McConnell's boiler of 1852-53 is shown by Fig. 163. Its outstanding features were very large grate¹⁷ and fire-box volume, the latter obtained by extending the upper part of the fire-box into the barrel, thus forming a combustion chamber. The fire-box and chamber were divided into two separate compartments by a longitudinal partition with water space between, and therefore two fire-doors were necessary. In the earlier examples each compartment had a vaulted semicircular roof, as in Hawthorn's 1839 patent. The front portion of the barrel contained 305 $1\frac{3}{4}$ in. tubes 7 ft. long in the case of the express engines (Fig. 106 *ante*), although the boiler diameter was only 4 ft. $3\frac{1}{4}$ in. outside.

The principle of the combustion chamber was good and has since been extensively used in modern American practice, but the dimensions and details were faulty. In spite of the extra complication the evaporative power was poor. On the other hand, the coal burnt was much cheaper than coke, and there was absence of smoke. To cram 305 $1\frac{3}{4}$ in. tubes into the barrel was a mistake and impeded free giving off of the steam. The combustion chamber appears to have been too long in relation to the tube length and the steam space was very restricted. The top of the vaulted roof of the fire-box was too far from the grate. McConnell stated ("Proc.," Inst. C.E., Vol. XII.) that by placing the tube plate some distance within the boiler the tubes were not liable to be choked with cinders, and this made it possible to reduce the tubes from $1\frac{3}{4}$ in. to $1\frac{3}{8}$ in., "giving in the same boiler an equal flue area with an increased proportion of tube heating surface." (?) He also gained a large addition of flame surface.

The above-mentioned reduction of tube diameter from $1\frac{3}{4}$ in. to $1\frac{3}{8}$ in. is not borne out from either the Wolverton official records or McConnell's own specification of the 7 ft. 6 in. express engines, 300 class. Nearly all his engines, both passenger and goods, had $2\frac{1}{4}$ in. or $2\frac{1}{2}$ in. tubes, but in those with long combustion chambers the tube diameter was $1\frac{3}{4}$ in., the smallest size recorded at the time when he made this statement. Probably he was speaking from memory, and meant a reduction from $2\frac{1}{4}$ in. to $1\frac{3}{4}$ in.

Although the boilers were coal burners, they were also used for coke, and in Woods and Marshall's trials of engine No. 300 (D. K. Clark, "Railway Machinery," page 315) coke was the

¹⁷ The illustration shows a long boiler engine with overhanging fire-box, and consequently short grate. The express engines had grates varying from 5 ft. $10\frac{1}{2}$ in. in the earlier to 7 ft. long in the later examples.

fuel used. As coke burners they were not successful, the smoke-box temperatures being exceedingly high, and were said to have reached 1100 deg. to 1200 deg. Fah.

spaces were only $\frac{1}{2}$ in. The double fire-box with longitudinal partition was retained.

J. Beattie's Boiler.—The coal-burning fire-box by Joseph Beattie dated from 1853, and consisted

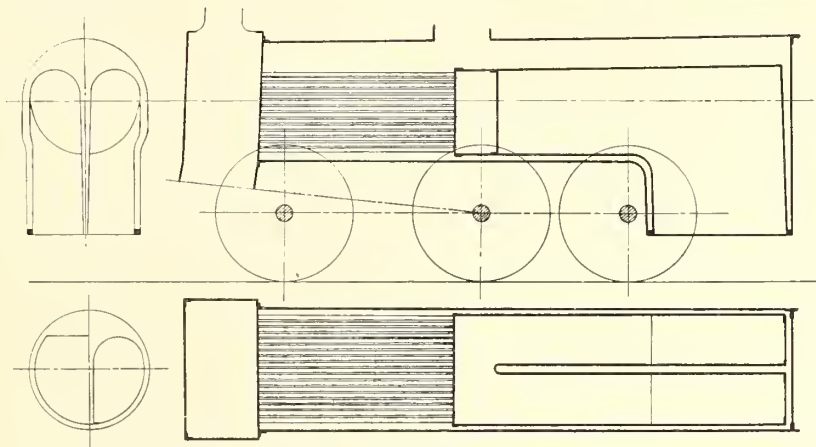

Fig. 163—McConnell's System, London & North-Western Railway

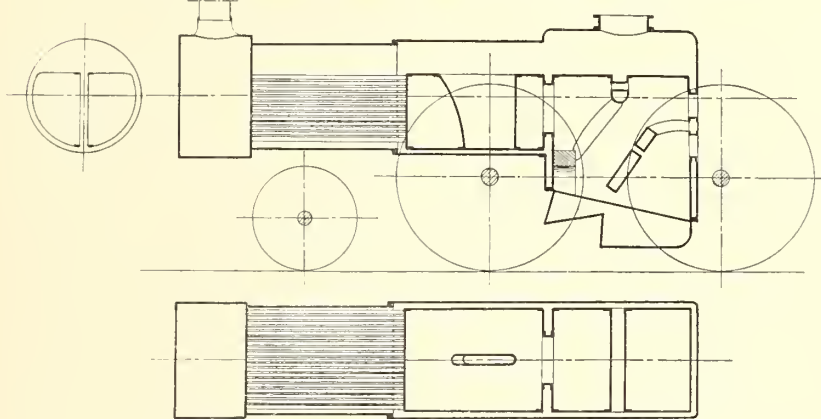

Fig. 164—Beattie's System, London & South-Western Railway

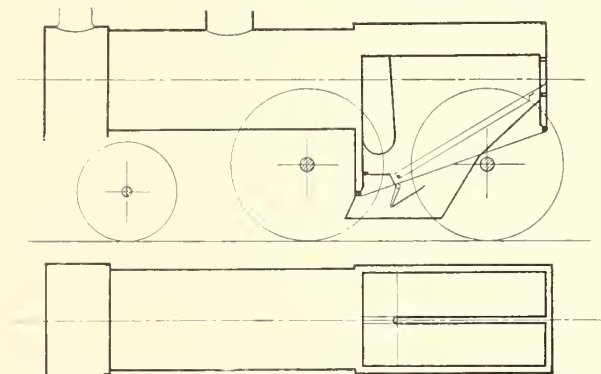

Fig. 165—Cudworth's System, South-Eastern Railway
COAL BURNING FIRE-BOXES, 1852-59

In his later boilers of 1862 McConnell compromised by shortening the combustion chamber, reducing the tubes to 214 and lengthening them to 9ft. 4in., though their diameter was increased from $1\frac{3}{4}$ in. to $1\frac{7}{8}$ in. Even in this case the tube

of an auxiliary small box and grate placed outside at the back of the ordinary fire-box. Coal was burnt only in the latter and coke in the former. The main box had a transverse water bridge or diaphragm. The underlying idea was common to

all Beattie's fire-boxes, in that the gases from the coal in the back box passed over incandescent fuel in the front box nearer the tube-plate, thus completing the combustion.

In 1855 Beattie produced an extended and more complete modification of his system. The small outer fire-box was suppressed, and in its place the main fire-box was divided transversely by an inclined water bridge into back and front compartments, each with its separate fire-hole. The two fire-holes were in the same vertical plane, the lower one serving the back compartment. The two compartments had separate dampers. The heaviest coal firing was done in the back compartment, the gases from which passed through openings in fire tiles over the water bridge, and were then deflected downwards by the water pocket in the roof on to the incandescent fuel in the front compartment, in which only a little coal was burnt slowly. Thence the gases passed through a fire tile heat "accumulator" into a combustion chamber, which occupied half the length of the barrel, and contained a second fire tile heat accumulator. From the combustion chamber the gases passed through the tubes to the smoke-box. As these tubes were only about 5ft. to 6ft. long, a very large number, 370 to 400, only $1\frac{3}{16}$ in. or $1\frac{1}{4}$ in. diameter, were used. The combustion chamber, like the fire-box, had a flat roof and was stayed with longitudinal girders.

In 1859 the boiler had developed into the form shown by Fig. 164, which was similar in general design, but the fire tiles, which had proved a source of trouble, were discarded.

In place of the tiles in the fire-box the perforated brick arch shown was substituted, and those in the combustion chamber were replaced by a narrow vertical midfeather, which connected the water spaces above and below the chamber. The wide passage between the fire-box and combustion chamber was also replaced by a series of tubes not shown. Air was admitted through hollow stay bolts in the sides and ends of the fire-box. This was probably the most fearful and wonderful boiler and fire-box ever placed in service on a large scale, and must have caused the running shed boiler repairing staff furiously to think. But it was undoubtedly most efficient as a means of extracting heat units from the fuel, and there were no locomotives in the kingdom which could touch Beattie's in fuel economy, of which part was due to the feed-water heating apparatus. In fact, it is doubtful whether the boilers could have been kept long in service had they been fed with cold water. Nevertheless, in spite of the hot feed, the complicated combustion chamber, with its adjuncts, had to be discarded, and in Beattie's later engines, from about 1863, only the double fire-box was retained.¹⁸ It remained standard on the London and South-Western Railway until 1877.

¹⁸ See drawing of Beattie's 2-4-0 tank engine, THE ENGINEER, February 5th, 1892.

Cudworth's Fire-box.—J. I. Cudworth, on the South-Eastern Railway in 1857, designed the double fire-box with sloping grate, 7ft. 6in. long—shown by Fig. 165. It was divided by a longitudinal water partition, and two separate fire doors, as in McConnell's system, were required. The fire-box volume was obtained without any complicated combustion chamber. Each side was fired alternately, the coal being put on underneath the doorways, where most of the gases were given off. The shaking of the engine when running caused the incandescent fuel to descend gradually along the sloping grate to the front, and the gases passing over it were properly consumed. The partition was cut away near the tube-plate, so that the gases from the two compartments could combine before entering the tubes. Cudworth's fire-box was fitted to all the S.E.R. engines, and some were in service until 1891. A large number were also used on the London, Chatham and Dover and the Brighton railways.

Other Coal-burning Systems.—Jenkins on the Lancashire and Yorkshire Railway in 1857 used tubular stays in the front of the fire-box, and added a small hook-shaped cast iron arch in the position in which the brick arch is now placed. Yarrow on the Scottish North-Eastern Railway employed a similar arrangement with a brick arch, but the brick arch had already been fitted to a number of Midland engines. A chimney blower formed part of both systems. D. K. Clark's air induction steam jets in the sides, and later in the front and back of the fire-box, were also introduced in 1857, and after trials on the North London and Eastern Counties Railways were adopted in 1859 as standard practice on the Great North of Scotland Railway. When running the steam jets were only put into action occasionally, since the blast was then sufficient to draw a large supply of air through the tubes. The steam jets were turned on as soon as the regulator was shut. In effect, therefore, they took the place of an ordinary blower, but were more effective than the latter, since the drawn in air was distributed over the surface of the fire and effected more complete combustion of the gases.

Coal Consumption and Evaporation.—D. K. Clark ("Proc.," I.C.E. 1860) gave the following results obtained from the chief systems mentioned above, with trains of 102 to 116 tons gross weight, and average speeds, excluding stops, of 33 miles per hour:—

	Pounds coal per mile.	Pounds per ton-mile.	Water per pound of coal.
McConnell	35½	.31	5.9
Beattie, with feed water heater shut off	24	.235	8.31
Cudworth	26	.225	8.6

Midland Railway Coal-burning Engines.—It was on the Midland Railway, between 1856 and 1860, that the final solution of the bituminous coal-burning fire-box problem was attained. The experiments covered a long period and were carried out by Charles Markham under Matthew

Kirtley's direction. Various expedients were tried, including air tubes in the fire-box front and sides. Then brick arches of various shapes were added, and finally firehole door deflector plates of various lengths and inclinations. Some experiments included the use of a

fire. Full particulars of the experiments were given in a paper by Charles Markham, "Proc.," Inst. Mech. Engineers, 1860.

It appears to the writer that one of the main reasons why the Midland locomotive department succeeded in adapting the ordinary plain coke-

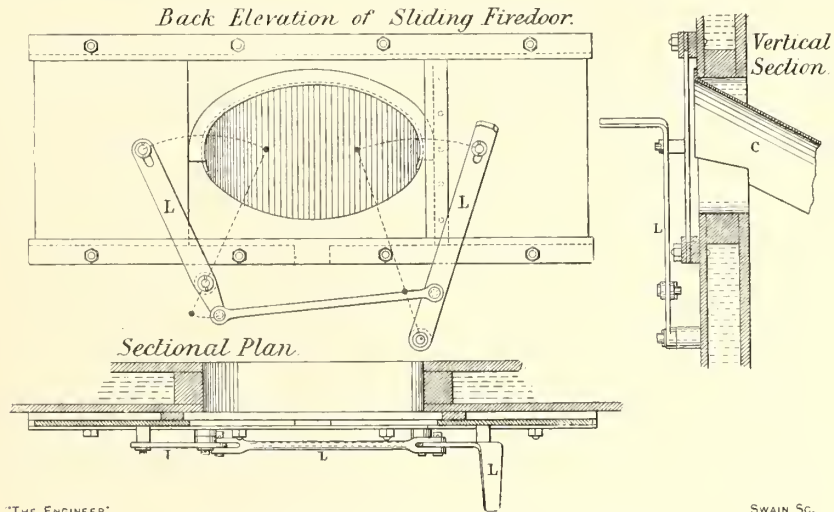
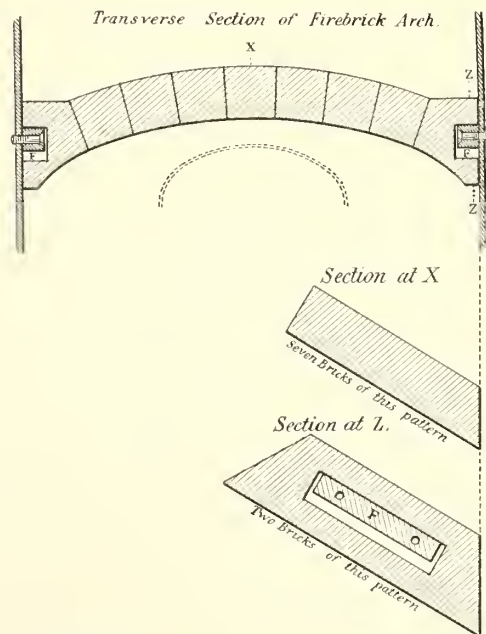

FIG. 166—MIDLAND RLY. FIRE DOOR, 1856-60

form of combustion chamber built up of firebricks inside the fire-box. Eventually all ideas involving air holes and combustion chamber were discarded, and the tests concentrated upon the best combinations of simple brick arch and deflector plate. With regard to the latter Markham observed "that every addition made to the length of the deflecting plate attached to the fire-door was attended with marked improvement in the combustion of smoke, the plate causing the air to be deflected on to the surface of the fire." Transverse fire-box midfeathers were found to be troublesome owing to the difficulty of cleaning and removing clinker from the front part of the fire-box. Deflecting plates attached to the fire-door were found to be less convenient than loose scoops, which were substituted for them. The fire-holes were enlarged to an oval form, 18in. wide by 11in. high, and the doors made of the well-known double-sliding pattern actuated by levers, one of the simplest and most convenient doors ever designed—Fig. 166. They have the advantage that when running with the doors very slightly open the air enters at the middle only and is deflected down into the centre of the fire-box.

burning fire-box for coal-burning, whereas McConnell, Beattie, and others found it necessary to adopt combustion chambers, midfeathers and other complications, was that the Midland engineers made most of their experiments with goods engines, of which the original coke-burning boilers were of large size, with greater heating



"THE ENGINEER"

SWAIN SC.

FIG. 167—MIDLAND RLY. BRICK ARCH, 1859

By the end of 1859 the Midland had arrived at the simple fire-box, with brick arch and deflecting plate as we know it to-day. The final form of brick arch—Fig. 167—consisted of nine blocks, seven 20in. long by 5in. thick, and two special side bricks with recesses to allow them to be supported by square bars, which were hidden in the recesses and therefore not exposed to the

surface and larger fire-box volume than was then usual. They had 1131 square feet of heating surface, of which the fire-box supplied 84 square feet. The volume of the latter was about 69½ cubic feet, and the grate area 14.5 square feet. The tubes, 2in. diameter, were 11ft. 9½in. long, with ample space between them.¹⁹ Except that the grate area was somewhat small owing to the partition, the Midland boilers of 1852-59 otherwise approximated in dimensions to those built for most other railways during 1865-74, when coal burning had become general. In 1852-53, when Beattie and others began their experiments, the ordinary coke-burning fire-boxes of the engines at their disposal were of considerably smaller dimensions, and the subsequent complicated designs resulted from efforts to obtain sufficient space and length of run for complete combustion of the gases.

The far-reaching results of the Midland experiments were not fully appreciated for some time. D. K. Clark²⁰ pointed out that in the Midland trials Derbyshire hard coals evaporated only 6.7 lb. of water per pound of coal, whilst Durham coke evaporated 7.9 lb. of water per pound of coke, or 18 per cent. more water. The cases can hardly be compared, if only for the reason that the goods engines, in which coke was tried in the experiments, were of very different dimensions from those using coal, though this fact was not mentioned in Markham's paper. The only fair comparison which can be made lay in the results given by two exactly similar passenger engines, No. 131, fitted with brick arch and deflector plate for coal burning, and No. 135 burning coke. These engines gave the following results:—

Engine.	Fuel.	Pounds fuel per mile, average.	Pounds water per pound fuel, average.
131	Shireoaks coal	21.38	7.0
131	Rhondda Valley coal	18.9	7.75
135	Durham coke	23.5	7.7

The coal was reported as producing clinker which affected the production of steam. When the relative costs of coal and coke are taken into consideration, there can be no doubt as to the value of the Midland results.

It should be mentioned that the fire-hole deflector plate was also independently introduced

¹⁹ Markham only gave the total heating surfaces in his paper, but the numbers of the engines were given, from which the writer has been enabled to add the above dimensions.

²⁰ Colburn's "Locomotive Engineering," supplementary chapter on "Coal Burning," page 299.

by G. K. Douglas, of the Birkenhead, Lancashire and Cheshire Junction Railway early in 1858.

Welsh Coal Burning in Locomotives.—The problem of burning Welsh steam coal of the comparatively smokeless variety differed from that which faced engineers who were testing bituminous coal. Its solution was undertaken by Joseph Tomlinson on the Taff Vale Railway in 1858.²¹ Tomlinson had previously been one of Matthew Kirtley's assistants on the Midland, and was probably fully conversant with the trials then being made on the latter railway. The Welsh coal contained about 90¼ per cent. of carbon and was in this respect nearly equivalent to coke. The absence of smoke rendered complicated fire-boxes and combustion chambers unnecessary, and neither brick arch nor deflector plates were required. Not even a steam jet or blower had to be used when the engine was standing. The difficulties arose owing to the intense heat of combustion on the grate. The wrought iron fire-bars burnt out, and would not last two days without having to be sent to the smiths' shop to be straightened, and some engines had to have two new sets per day to run 100 miles. With heavy firing the bars fused. Eventually, good results were obtained by covering the fire-bars with a layer of broken fire-bricks in small pieces, after which they lasted about four months. The spaces between the bars, which had been 1in. in coke-burning fire-boxes, were reduced to ½in., and the fire-door was made with five or six 2in. holes to admit a little air above the fire.

The fuel consumption was found to be slightly in favour of coal, as compared with coke. The water evaporated was from 7½ lb. to 8 lb. per pound of coal, and was practically the same as with coke. These results were obtained on slow-speed coal trains, at speeds of 11½ to 16½ miles per hour, but when the speed was 50 per cent. higher the increased fuel consumption resulted in a 10 per cent. decrease in the water evaporated per pound of coal. The cost of coke at that time was 12s. 6d. and of coal 6s. 8d. per ton.

In addition to the economy in cost of fuel from the substitution of coal for coke, there was a considerable saving in the upkeep of fire-boxes and tubes. On an average throughout the kingdom, a set of brass tubes would last 150,000 miles, as against 100,000 miles when coke was used, and the fire-box abrasion, which was very severe, especially under the fire-door and in the lower portions of the box, when coke was used, was reduced in an even greater proportion.

²¹ "Proc." Inst. Mech. E. Paper by Joseph Tomlinson, 1858, on "Burning of Welsh Coal in Locomotives."

Chapter XI—British Locomotives for Abroad

WITH the exception of one or two engines of special design built in 1832-35 for American railways, no mention has so far been made of locomotives exported overseas, because until about 1852 the types and classes were generally of the makers' standard designs used in this country.

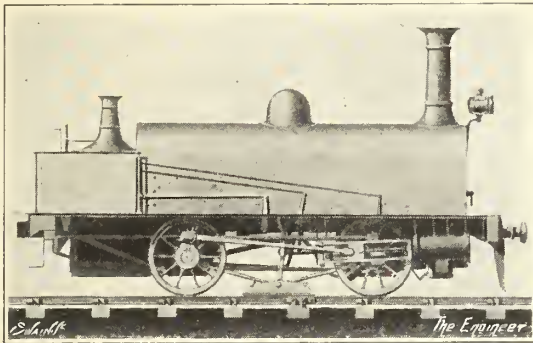

FIG. 168—ENGINE FOR GIOVI INCLINE, ITALY, 1855

European Railways.—The products of the majority of the British locomotive manufacturers were represented on the European Continent, though the larger number of engines were by Stephenson and Sharp. Before 1850 the output of the French and German firms had become equal to the requirements of these countries, and with a few isolated exceptions, orders from the latter ceased. By 1856 the export of engines to Belgium had also practically stopped. There still remained a trade with railways in other countries, which were later in adopting railway transport.

It is not proposed, nor is there any necessity, to describe engines built for the Continent, except in the case of two special designs which were not represented in this country.

Twin Tank Engines by R. Stephenson and Co. for the Giovi Incline, Italy.—These were built for working the heavy gradients of 1 in 29 to 1 in 36 on the main railway between Turin and Genoa. The problem of special locomotives for long steep gradients with severe curves confronted Continental engineers before its solution was demanded from British builders, and in 1852 the Austrian Government offered prizes for locomotives adapted to work the Semmering inclines. No British makers competed, and of the four special designs evolved, those by Maffei and Engerth never had their counterparts in British practice. On the other hand, the double boiler articulated locomotive on two steam bogies, by Cockerill, of Seraing, was the forerunner of the "Fairlie"

engine, and the single boiler articulated engine, by W. Gunther, of Wiener Neustadt, was the prototype of the "Meyer" type.

The Italian engineers were not satisfied with the designs for the Semmering, and suggested that two engines placed back to back would be simpler, provided they were arranged with the equivalent of a single footplate so that one engine driver could be responsible for their working, though two drivers and one fireman were subsequently employed. Robert Stephenson was consulted and approved of this suggestion.¹

The first Giovi engines of 1855 consisted of two 0-4-0 saddle-tank locomotives back to back. One of these units is shown by Fig. 168.² The saddle tank contained 3 tons of water, and was of such a length that the ratio of weight distribution on the two axles remained approximately the same as the water and fuel were consumed. The cylinders were 14in. by 22in., and the coupled wheels 3ft. 6in. diameter; wheel base, 8ft. 6in.; total heating surface, 731.5 square feet; weight in working order, 27 tons 12½ cwt. The maximum total adhesive weight for the pair of engines was, therefore, 55½ tons, but as there were 2½ miles of damp tunnel, in which the coefficient of adhesion was low, the boiler pressure was limited to 88 lb.

The excentric sheaves were forged solid with the driving axle, and sledge brakes, the shoes of which were 2ft. 8in. long, were provided.

In service it was found that the weight of more than 13¾ tons per axle was too great for the rails, and subsequently Messrs. Stephenson built twin 2-4-0 and 0-6-0 types for the same railway.

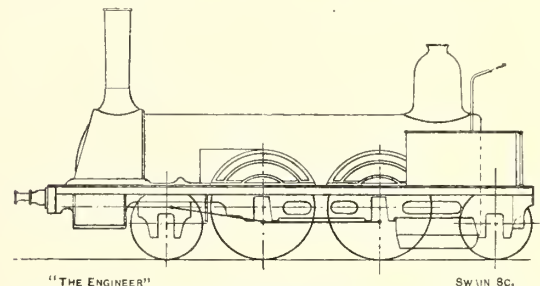

FIG. 169—STEPHENSON'S ENGINE FOR THE GREAT LUXEMBOURG RAILWAY, BELGIUM, 1860

The twin system with two engines back to back was also used in India (1858) and on the Cape Government Railways (1875).

2-4-2 Passenger Tender Engine.—The 2-4-2 type for so long associated with French practice,

¹ The original idea was due to T. R. Crampton, who patented it in August, 1846 (Colburn, page 91).

² For this illustration the writer is indebted to R. Stephenson and Co., Ltd., Darlington.

had its origin in this country in 1860, when R. Stephenson and Co. built an engine—Fig. 169—for the Belgian Great Luxembourg Railway.³ Robert Sinclair, through whom the engine was

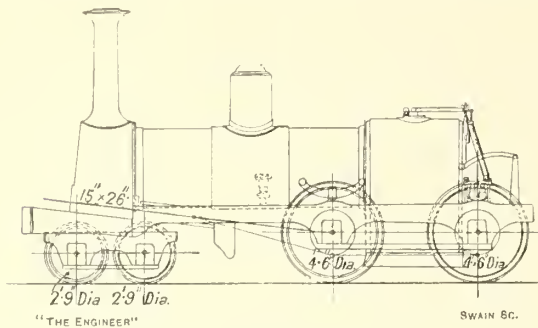

FIG. 170—HAWTHORN'S ENGINE FOR THE ARICA & TACNA RAILWAY, SOUTH AMERICA, 1854

ordered, suggested that Messrs. Stephenson should take their long boiler 2-4-0 engine with outside cylinders and add a pair of small wheels at the trailing end, and he also proposed that both the leading and trailing axles should be made to swivel by means of Bissell trucks.⁴ This would have resulted in an unsteady motion, and the engine was built with a "Bissell" at the leading end only, and was the first constructed in this country with a two-wheeled pony truck. The length of the radial arm was 4ft. 0 $\frac{1}{4}$ in. The

17ft. 4in. The boiler contained 121 2 $\frac{1}{8}$ in. tubes, 13ft. 10in. long. Heating surface 1001 square feet, of which the fire-box provided 70 $\frac{1}{2}$ square feet. The sloping smoke-box front was a feature of many of Sinclair's designs. Compensating levers were placed between the springs of the coupled wheels.

The 2-4-2 tender engine never took root on British railways, for which none were ever built, unless exception be made of twenty Webb compound locomotives of the "Greater Britain" type of 1891 with uncoupled driving wheels. From 1873 onwards it was adopted on some of the French railways on a very large scale, and there were also many examples in Belgium and Germany.

Bogie Locomotives for Abroad.—The severe curves on some of the Chilean and Peruvian railways necessitated the use of bogies. R. and W. Hawthorn's engines for the Arica and Tacna Railway—Fig. 170—had inside cylinders 15in. by 26in., coupled wheels 4ft. 6in. and bogie wheels 2ft. 9in. diameter; bogie wheel base, 3ft.; total wheel base, 18ft. 2in. In 1858 Messrs. Kitson built four 4-4-0 engines—Fig. 171—with outside inclined cylinders for the Copiapo and Caldera Railway. The tenders were also carried on two four-wheeled bogies. The engine bogie had a fixed centre pivot, 3ft. 6in. wheels and 5ft. base; cylinders, 16 $\frac{1}{2}$ in. by 24in.; coupled wheels, 5ft. 2in. diameter; total wheel base, 15ft. 6 $\frac{1}{4}$ in.,



FIG. 171—KITSON'S ENGINE FOR THE COPIAPO & CALDERA RLY., CHILE, 1858

cylinders were 15in. by 22in., coupled wheels 5ft. 6in., and leading and trailing wheels 3ft. 8in. diameter. Wheel base 5ft. 4in. + 6ft. =

³ During the same year Schneider and Co., of Creusot, built two 2-4-2 passenger engines for the Great Russian Railway.

⁴ For this information the writer is indebted to R. Stephenson and Co., Ltd.

the distance between the coupled wheel centres being 8ft. 3in. Total heating surface, 1068 square feet. The American cab with open front and weatherboard may be noticed. Both connecting and coupling rods were of circular section.

R. Stephenson and Co. also built ten 4-4-0 engines with outside cylinders for the Smyrna-Aidin

Railway in 1859. The cylinders were horizontal, and the bogie necessarily had a long wheel base in accordance with modern standards.⁵

The first 4-6-0 engines built in this country, which the writer can trace, were made by R. and

frames and inside cylinders, 14in. by 20in. The fire-box casings were of the old "Gothic" type. Amongst the many types built between 1852 and 1860 by various British firms the canopied 2-2-4 tank engine—Fig. 172—deserves mention. It was

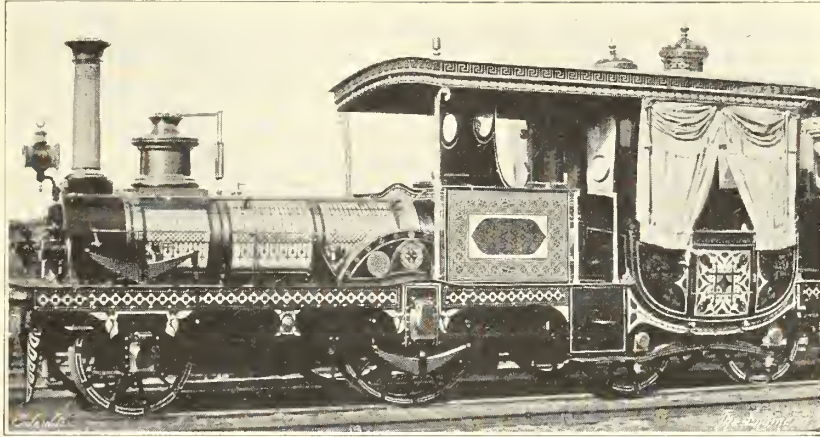

FIG. 172—STEPHENSON'S ENGINE FOR THE VICEROY OF EGYPT, 1859

W. Hawthorn in 1860 for the Copiapo Extension Railway to the general designs of Mr. Edward Woods. The rails weighed only 42 lb. to the yard, and the weight on any pair of wheels could not exceed 7 tons, so that three coupled axles were necessary. The coupled wheels had a diameter of 4ft., and the outside cylinders were 16in. by 24in., coupled wheel base 10ft. 9in., the front pair being

made by Messrs. Stephenson in 1859 for the Viceroy's private use, and, like many Egyptian locomotives of that period, was most elaborately and expensively decorated. The cylinders were 8in. by 14in.; diameter of driving wheels, 5ft.; total heating surface, 409½ square feet.

Messrs. Stephenson also built in 1860 two heavy 0-6-0 goods engines with 5ft. wheels and 17in. by

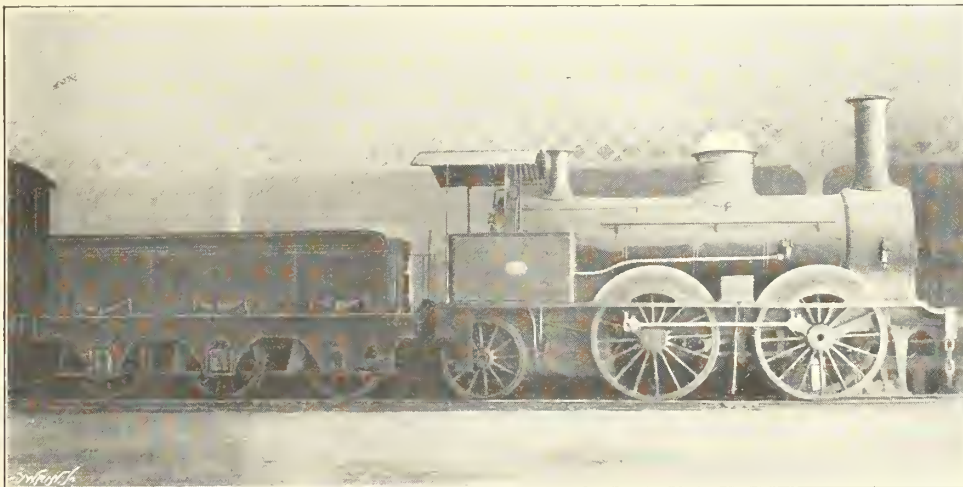

FIG. 173—STEPHENSON'S ENGINE FOR THE SYDNEY & GOULBURN RLY., NEW SOUTH WALES, 1854

without flanges. The whole of the motion was outside, Gooch's valve gear being used.

Locomotives for Egypt.—The first engines for Egypt were built in 1852 by R. Stephenson and Co. They were 2-4-0 passenger engines with inside

28in. cylinders. These were the first built in this country with such a long stroke.

Locomotives for British Colonies.—The earliest engines exported went to the other side of the Atlantic. In 1838 Timothy Hackworth built three six-coupled engines with vertical cylinders and return-flue boilers for the Albion Coal Mining

⁵ One of these engines is illustrated in "A Century of Locomotive Building," page 410.

Company, Nova Scotia. They were fitted with parallel motion instead of crossheads and guide bars.⁶ They appear to have been the first locomotives in what is now the Dominion of Canada.

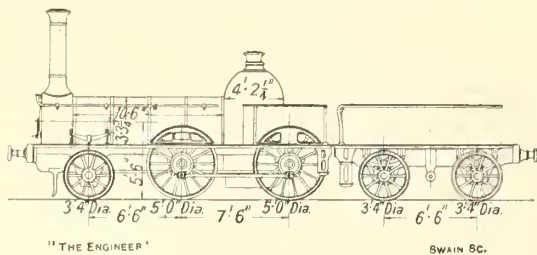

FIG. 174—VULCAN ENGINE FOR THE GREAT INDIAN PENINSULA RAILWAY, INDIA, 1852

In 1845 Sharp Bros. built four single-driver engines for Jamaica, and in 1853 sent an engine to Demerara.

It was not until 1854 that the first locomotives were sent to Australia—see Fig. 173. Built by Stephenson and Co. for the Sydney and Goulburn Railway, they were obviously of J. E. McConnell's design, and had 5ft. 6in. leading and driving wheels and 16in. by 24in. cylinders. One of them is still preserved at Sydney. Two engines by Stephenson and Co., 1859, for the Adelaide and Gawler Bridge Railway, South Australia,

Locomotives for India.—Comparatively little has been published concerning the earlier Indian engines, so that a few brief notes may be of some interest.

The first public railway to be opened for traffic was the 5ft. 6in. gauge section of the Great Indian Peninsula Railway between Bombay and Thana, on April 16th, 1853, followed by an additional length to Kalyan, 33 miles. The first main line locomotives in India were eight 2-4-0 engines built by the Vulcan Foundry in 1852—see Fig. 174—for the above section of the G.I.P.R. They were of very small dimensions, the cylinders being only 13in. by 20in. and the coupled wheels 5ft. diameter; total heating surface, 777½ square feet. The high dome-shaped fire-box casing and the tender wheels with inside bearings were the principal features.

These engines had inside frames and bearings throughout. This simple design was a feature of the 5ft. 6in. gauge locomotives for India, and with only one exception outside or double frames were never used. The additional width between the frames due to the wider gauge allowed ample room for inside bearings of adequate length and crank webs of sufficient thickness. The "mixed" frame, in which the carrying wheels only had outside bearings, was also rare, the exceptions being a few 2-2-2 and 2-4-0 engines of the

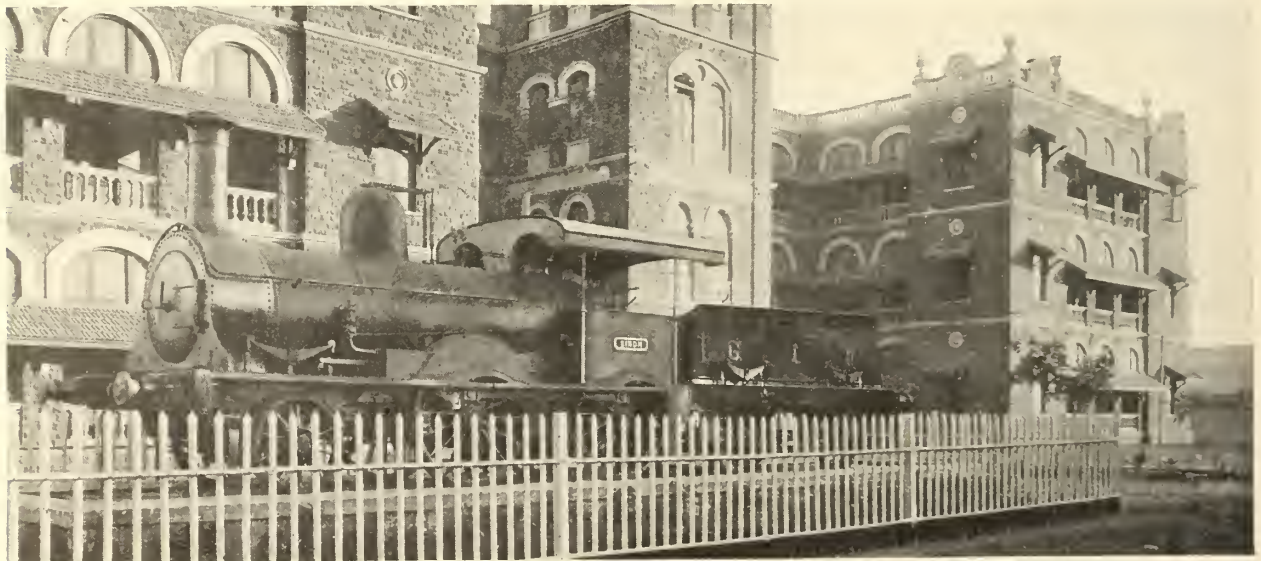

FIG. 175—KITSON'S PASSENGER ENGINE FOR THE GREAT INDIAN PENINSULA RAILWAY, 1856, PRESERVED AT PAREL LOCOMOTIVE WORKS, BOMBAY

were of the 4-4-0 type with leading bogies. The earliest Victorian engines were built by Stephenson's in 1855 for the Geelong Railway, and were followed by others in 1857 by George England and Co., of Hatcham Ironworks, London.

⁶ These engines are described and illustrated in "Timothy Hackworth and the Locomotive," by Robert Young.

"Crewe" type with outside cylinders. Inside cylinders were the general rule, though between 1860 and 1869 the majority of the East Indian Railway engines and a limited number on other lines were built with outside cylinders.

Returning to the G.I.P.R., the subsequent passenger engines by Kitson and Co., 1856, were of

a larger 2-4-0 type with 5ft. 6in. coupled wheels and 15in. by 21in. cylinders. This type, with cylinders enlarged to 16in. by 22in., was the favourite design for about twenty years on most Indian railways. Fig. 175 shows one of these

The weight of the engine in working order was $27\frac{1}{2}$ tons and of the six-wheeled tender $20\frac{1}{2}$ tons.

The goods traffic of the E.I.R. was for more than twelve years conveyed by four wheels coupled "mixed traffic" engines of the 0-4-2

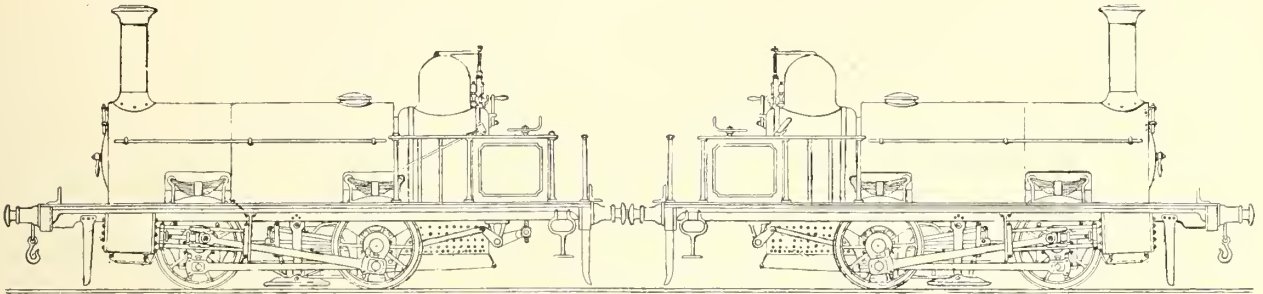

FIG. 176—PAIR OF WILSON'S TANK ENGINES FOR THE GHAT INCLINES, G.I.P. RLY., 1856

engines—"Sindh"—preserved in front of the chief mechanical engineer's offices at Parel, Bombay.

The first Ghat engines were built by E. B. Wilson and Co. in 1856. They were four-coupled tank engines, which worked in pairs back to back similarly to Stephenson's Giovi tank engines. Each of Wilson's engines had outside cylinders, 15in. by 22in., and 4ft. wheels. The first of these engines started work in July, 1858. In the early days of Indian railways, locomotives had to be built one-and-a-half to two years before they were placed in service. Fig. 176 shows a pair of these little engines as originally built.

The first main line passenger engines for the

type. There were eighty of these engines by the Vulcan Foundry, Hawthorn, E. B. Wilson, Kitson, Fairbairn, and Stothert and Slaughter. The cylinders were 16in. by 22in.; diameter of coupled wheels, 5ft.; of trailing wheels, 3ft. 9in.; total heating surface, 1156 square feet; grate area, 18 square feet. Many of these engines had a length of service of forty to forty-five years.

A historic East Indian Rly. 2-2-2 tank engine is shown by Fig. 177. A number of engines to this design were built by Kitson and by Stothert and Slaughter in 1856-57 for local traffic in the Calcutta district. The engine "Express," illustrated, was one by the latter firm. It had 6ft. driving wheels and 12in. by 22in. cylinders. It

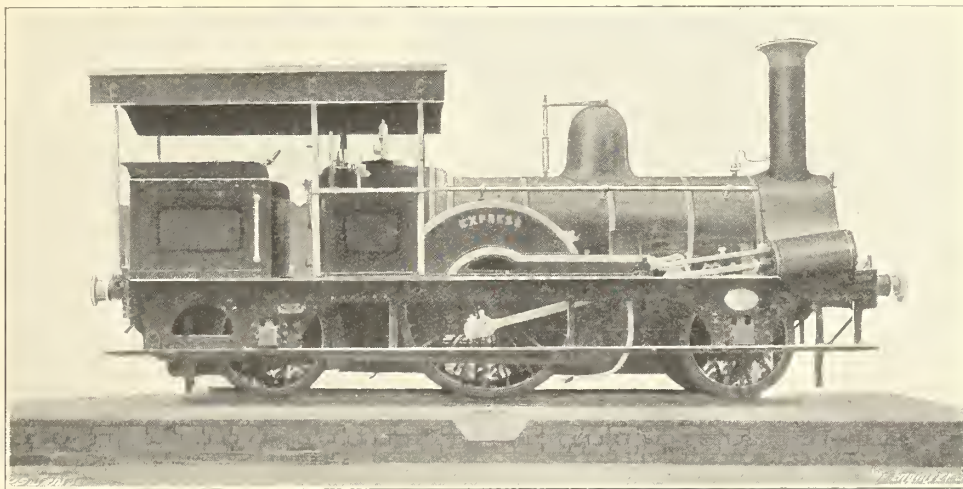

FIG. 177—STOHTERT & SLAUGHTER'S LOCOMOTIVE FOR THE EAST INDIAN RAILWAY, 1856, MOUNTED ON A PEDESTAL AT THE JAMALPUR LOCOMOTIVE WORKS

East Indian Railway, built in 1855-56 by Beyer, Peacock and Co., the Vulcan Foundry, and E. B. Wilson, were of the 2-2-2 type with 6ft. 6in. driving wheels and 15in. by 22in. inside cylinders.

has the appearance of John V. Gooch's Eastern Counties design with outside cylinders and mixed framing. The "Express" is now preserved at the Jamalpur locomotive shops on a pedestal on

which it was placed in 1901 during Mr. Alan W. Rendell's superintendency. The inscription records that it was the first locomotive which ran passenger trains between Howrah and Ranee-gunge, and also that it conveyed troop trains to the latter station during the memorable year 1857.

A number of early tank engines on the E.I.R. were of the 0-4-2 type with coupled wheels 4ft. diameter and outside cylinders 12in. by 18in.; they were followed by a somewhat larger class with 4ft. 6in. wheels and 14in. by 18in. cylinders. All were built in 1857-59 by Stothert and Slaughter, of Bristol.

Another of these tank engines, named "Faerie Queen," is mounted on a pedestal inside the Howrah terminus, Calcutta.

The Madras Railway 2-2-2 passenger engines by Kitson, 1856, were similar to the tank engine "Express" of the E.I.R., but were provided

with separate tenders. This railway was the first in India to employ 0-6-0 goods engines. They were built to Mr. (afterwards Sir) John Hawkshaw's designs by Beyer, Peacock and Co. in 1858, and had 5ft. wheels and 16in. by 22in. cylinders. The weight in working order was $28\frac{1}{2}$ tons; the tender weighed $19\frac{3}{4}$ tons when fully loaded. In appearance they were somewhat similar to the goods engines—Fig. 153 *ante*—built by the same firm for Egypt, and were fitted with the Jenkins arch and tubular stays in the front wall of the fire-box, as used on the Lancashire and Yorkshire Railway for coal burning. A number of typical Indian locomotives of this period were illustrated in *The Engineer* as follows:—0-4-2 engine, by Beyer, Peacock, April 26th, 1867; 2-4-0 engine, by Sharp, Stewart, March 27th, 1868; 0-6-0 engine, by Sharp, Stewart, June 12th, 1868.

Chapter XII—1860-65

BETWEEN 1860 and 1865 the existing locomotive types were enlarged and improved, but only one or two new types were introduced. The most notable advance was in reality due to the steel maker, and we now meet with a rapidly extending use of steel tires and axles, and even tentative trials of steel boilers and fire-boxes. But although many of the locomotive engineers of that day almost immediately

1862. One of these as originally built was illustrated in *The Engineer* of December 1st, 1922, page 580, and in *The Locomotive Magazine* of October 10th, 1903.

The type was a direct derivative of the Allan "Crewe" engine with outside bearings for the carrying axles, and cylinders placed between the outside and inside frames. The large size of the driving wheels, 8ft. 2in., allowed the 17½ in. by

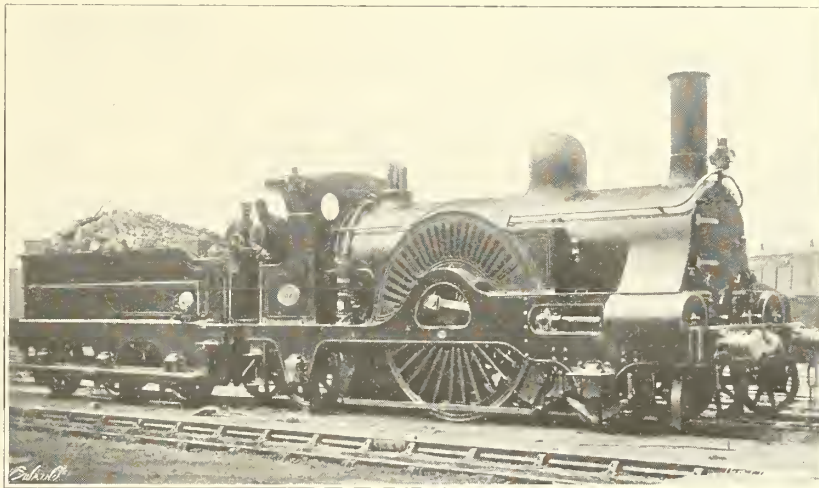

[Photo. Locomotive

FIG. 178—B. CONNOR'S LOCOMOTIVE FOR THE CALEDONIAN RLY., 1859—RE-BUILT

adopted steel tires, they were much more cautious when crank axles, and more especially steel boilers were concerned, and it was at least twenty years later before steel could be said to have gained the victory over Low Moor or Farnley iron. In addition to employing stronger material, the locomotive engineer was also endeavouring to design various methods of making his engines more flexible on curves. Injectors, screw-reversing gears, and the Ramsbottom tender water pick-up apparatus were also products of this period. These, together with other improvements in details, will be considered at the end of this section, after the more notable locomotives of the day have been described.

2-2-2 Express Engines.—Outside Cylinders.—At the end of 1859 Benjamin Connor built the first of the Caledonian "8ft." single engines at the company's works at St. Rollox. In all, twelve were constructed there between 1859 and 1865, and four more in 1875. There were also three exported by Neilson and Co. to Egypt, one of which was shown in the London Exhibition of

24in. cylinders to be placed horizontally, and in this respect the engines differed from the "Crewe" type, which had inclined cylinders. The general dimensions of this and other single express engines of the period are given in the table. The centre of the boiler was 6ft. 6¾ in. above rail level, some reduction in height being obtained by using Gooch's stationary link motion. The tires were of Krupp steel, and the driving axles of cast steel, made, according to Clark, at St. Rollox works. Incidentally it may be added that a large number of these straight driving axles broke in service; they were 6½ in. diameter throughout except at the journals, which were concave, and the wheel seats were also 6½ in. diameter. But whether the material or the dimensions were faulty has not been recorded. The driving wheels had crescent-shaped balance weights forged solid with the rims, and, as far as the writer can trace, these were the first examples of this construction. In Colburn's "Locomotive Engineering" D. K. Clark stated that the valves had 1½ in. laps and long travel for the special purpose of obtaining a free exhaust

at high speed from the exposed outside cylinders, in which steam was liable to condensation, and therefore more sluggish in leaving the cylinders. This was in accordance with R. Sinclair's practice. The engines were provided with cabs, injectors,

built from the end of 1859 to the middle of 1865, though, being sixty in number, were much more numerous. They were much lighter engines, with cylinders 16in. by 24in., 6ft. between centres, and driving wheels 7ft. 7½in. diameter, with only 11½

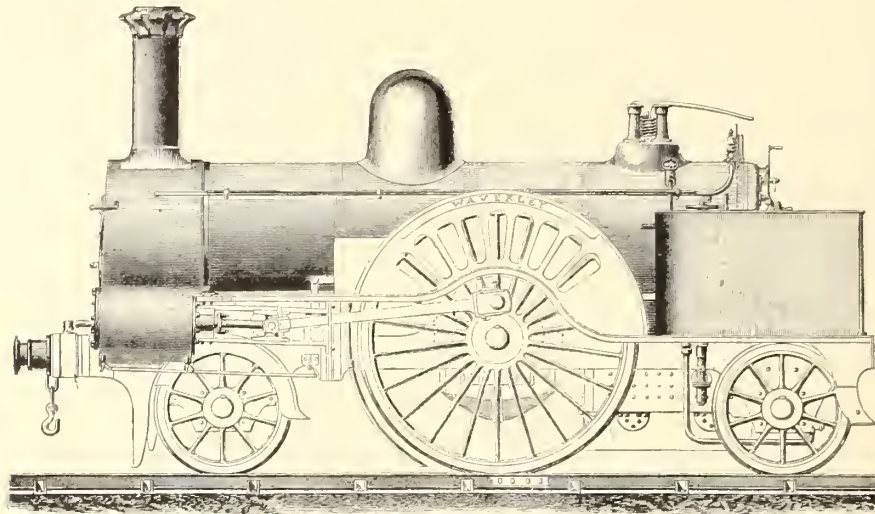

FIG. 179—J. RAMSBOTTOM'S L. AND N.W. RAILWAY EXPRESS ENGINE, 1859

and with brick arches and deflectors for coal burning. The weight—14 tons 11 cwt.—on the driving wheels was very heavy for the period. These engines rendered excellent service and worked the West Coast Scotch expresses between Carlisle and Glasgow and Edinburgh until 1883-4, when D. Drummond replaced them on the heaviest trains by coupled engines. In their rebuilt condition they were as shown in Fig. 178, with flush boiler, on the middle of which the dome was placed. As originally built the dome was on the fire-box casing, which was raised above the barrel.

tons on them. Unlike all preceding "Crewe" designs the carrying wheels had inside bearings only. To place the leading axle sufficiently far forward the cylinders were inclined, but nevertheless the wheel base, as in the case of the "Caledonian" and Great Eastern outside cylinder engines, was somewhat short. The writer frequently observed the running of the "Lady of the Lake" class from the platforms of wayside stations, and noticed that the engines swayed or "nosed" from side to side. The unbalanced portions of the reciprocating masses affected these

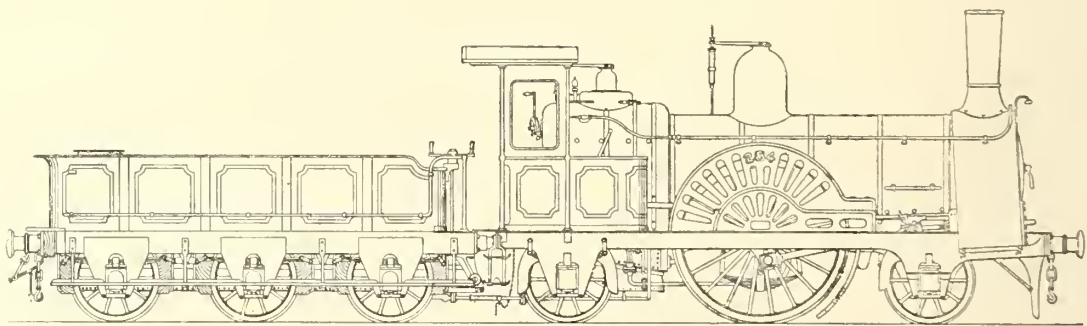

FIG. 180—R. SINCLAIR'S GREAT EASTERN RLY. EXPRESS ENGINE, 1862

The London and North-Western engines of the "Problem" or "Lady of the Lake" class—Fig. 179—by J. Ramsbottom, were contemporaries of the "Caledonian" engines, and were also

light outside cylinder engines to a considerable extent, and the effect was aggravated by the external action between the rails and the flanges of engines with short wheel base. In most respects

they were simple straightforward engines and presented several features of interest. The boiler was telescopic and pitched with centre 6ft. 7in. above the rails. The smoke-box was provided with an ash hopper, an arrangement initiated by Ramsbottom and used on most of the L. and N.W.R. engines until the end of F. W. Webb's superintendency. Horizontal screw reversing gear was fitted, the nut being connected to the reversing rod by a lever pivoted near the centre. The cylinders and valves were lubricated by means of condensation lubricators, and the 50 engines built from November, 1860, had Giffard's injectors, whilst the first ten were built with crosshead pumps.

Between 1895 and 1899 F. W. Webb rebuilt all these engines. The new boilers, which had somewhat larger fire-boxes, were raised about 3in., and the pressure was increased to 150 lb. The diameter of the driving wheels with thicker tires became 7ft. 9in., and volute springs replaced the plate springs under the driving axle. The weight was increased to 31 tons 7 cwt., of which 14 tons 5 cwt. was available for adhesion. About ten years later all were broken up. In their latest condition they were illustrated in *The Engineer*, December 25th, 1896, and April 16th, 1897.

Robert Sinclair's Great Eastern express engines with outside cylinders—Fig. 180—were built by Fairbairn, Kitson, the Avonside Company, and Schneider (Creusot) between 1862 and 1867. In them we again find the Allan "Crewe" type. The cylinders were 16in. by 24in. and the driving wheels 7ft. 1in. diameter. Other leading dimensions are given in the table. They had many features in common with the "Caledonian" engines, *e.g.*, the boiler barrels were parallel with circumferential butt strips, and Gooch's valve gear was employed. The weight on the leading axle was carried by a transverse plate spring, with the addition of a light longitudinal plate spring above each journal. Screw reversing gear was fitted. These engines worked the fastest main line expresses for more than twenty-five years.

It will be noticed that the celebrated French firm of Schneider et Cie. appears amongst the makers of these engines, of which they built six in 1866-67, the last being shown in the Paris Exhibition of 1867. At the same time they also constructed ten 2-4-0 engines for the Great Eastern. These were the first orders for locomotives for home railways which had been placed outside this country since the American Norris engines of 1840, the reason being that British firms were then too fully employed to be able to give quick delivery.

2-2-2 Express Engines with Inside Cylinders.—Of the type with inside bearings for all wheels, three remarkable engines—Fig. 181—were built at Wolverton in 1861 for the southern division of the L. and N.W.R. They were the last express engines designed by J. E. McConnell before his retirement in 1862 from the position of locomotive

TABLE I.—Single Express Engines, 1860 to 1865 Period.

Railway.	Designer.	Date	Cylinders.	Driving wheels.	Carrying wheels.	Wheel base.	Tubes	Heating surface		Grate area	Pres- sure.	Weight on driving wheels.		Total weight loaded.	
								Tubes.	Firebox			Total.	l.	c.	l.
1 C.R.	B. Connor	End of 1859	17½" × 24" outs.	8' 2"	3' 8"	7' 2" + 8' 6" = 15' 8"	192 1½"	1080	89	15.9	120	14 11	30 13		
2 L. & N.W.R. (N.D.)	J. Ramsbottom	Do	16" × 24" outs.	7' 7½"	3' 7½"	7' 7" + 7' 10" = 15' 5"	192 1½"	1013	85	14.9	120	11 10	27 0		
3 G.E.R.	R. Sinclair	1862	16" × 24" outs.	7' 1'	3' 7"	7' 0" + 8' 6" = 15' 6"	190 1½"	969	82.3	15.7	120	11 7½	29 5½		
4 L. & N.W.R. (S.D.)	J. E. McConnell	1861	18" × 24"	7' 7½"	4' 6"	8' 6" + 9' 6" = 18' 0"	214 1½"	980.3	242.5	25	150	14 6	34 14		
5 G.N.R.	A. Sturrock	1860	17" × 22"	7' 0"	4' 3"	9' 6" + 8' 6" = 18' 0"	164 2"	883.6	177	1660.6	150	13 7	34 12		
6 G.W.R.	D. Gooch	1862	16" × 24"	7' 0"	4' 0"	8' 0" + 8' 0" = 16' 0"	187 2" ½ 1½"	1226	122	14.6	130	12 16½	29 16		
7 S.E.R.	J. I. Cudworth	1861	1" × 22"	7' 0"	{ 4' 9" } { 4' 0" }	8' 6" + 8' 3" = 17' 3"	170 2"	974.9	163	21.2	130	12 12	33 2		
8 M.R.	M. Kirtley	1864	16½" × 22"	6' 8"	4' 2"	8' 0" + 8' 0" = 16' 0"	2"			16	140				

Nos. 1, 2 and 3 outside cylinders; Nos. 1 and 3 mixed frames; No. 2 inside frames; No. 4 inside frames; Nos. 5 and 6 double sandwich frames; Nos. 7 and 8 double plate frames.

superintendent. One was shown in the London 1862 Exhibition, together with Ramsbottom's "Lady of the Lake," to which it offered a complete contrast. The outside framed design of the 1852 engines—Fig. 106 *ante*—was discarded for

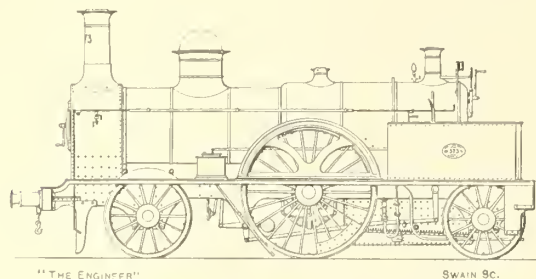

FIG. 181—J. E. MCCONNELL'S L. AND N.W. RAILWAY ENGINE, 1861

the simple inside plate frame of the "Bloomers," and to clear the crank axle the boiler centre was pitched 7ft. 5½in. above rail level, or about 9in. higher than in any other engine of that day. The boiler was provided with McConnell's combustion chamber, which was not quite so long as that of the previous engines, and allowed a tube length of 9ft. 4in. The fire-box had a longitudinal partition. The great length of wheel base—18ft.—should be noted.

These engines met with a considerable amount of hostile criticism, very much of which was unfair. Clark¹ wrote: "The great height of the centre of the boiler, 7ft. 5½in., is excessive, and tells upon the rails when the engine sways. In the 'Lady of the Lake,' though she has driving wheels as large, the centre is 11in. lower, and thus in conjunction with a compact wheel base and a balanced driving wheel, produces a safe, steady and easy running engine." Now, the McConnell engines, with their inside cylinders, were also

of the "Lady of the Lake" class mentioned previously certainly did. Moreover, when running at high speed on a straight road, such as the L. and N.W. main line, the steadying action of the 18ft. wheel base was a great advantage over the short 15ft. 5in. base of the "Crewe" engine. In 1874 coupled engines were built at Crewe works with wheel base 15ft. 8in., considerably less than that of McConnell's engines, though the boiler centre was 7ft. 4¾in. above rails, or only ¾in. lower. P. Stirling's inside cylinder 2-2-2 engine of 1886, with 7ft. 6in. driving wheels, had a 19ft. 1in. wheel base and a boiler centre 7ft. 6in. above rails. No one criticised these later engines on the grounds of instability. The criticisms of McConnell's complicated boiler were more to the point, but the truth is that much of the hostility to his engines emanated from Crewe. Old L. and N.W.R. main line drivers, who had driven both types of engine,² told the writer which of the two they preferred. It was not the "Crewe" engines, and they were fairly unanimous on the subject.

In Colburn, page 258, is given a comparative table of coal consumption of the two types of 7ft. 6in. singles from particulars supplied from Crewe. The "McConnells" burnt 41.68 lb. per mile, with trains averaging 11.7 vehicles, or 99.56 tons, and the "Lady of the Lake" class consumed 26.77 lb. per miles, with 8.58 vehicles, or 72.93 tons. But neither speeds nor gradients were mentioned. The "McConnells" were working the heavier and faster express trains over the London-Rugby section, and the "Ladies" mostly the light Irish mails between Stafford and Holyhead, an easier road for most of the distance, so that no proper comparison can be made. But although the conditions told against the "McConnells," there is no doubt that with light trains up to about 80 or 90 tons the "Lady of the Lake" class were more economical, in addition to which the repairs to their boilers must have been less.

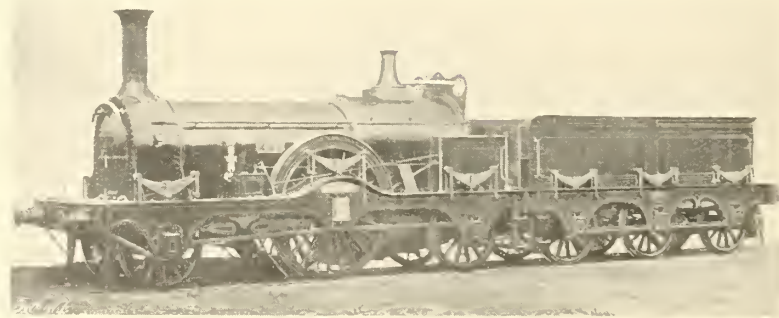

FIG. 182—A. STURROCK'S SINGLE DRIVER EXPRESS ENGINE, G.N. RLY., 1860

balanced, and rolled rather than swayed. But the rolling, which was not excessive, was taken up by the springs, and did not act against the rails in the way in which the short jerky lateral "nosing"

The engines numbered 5 to 8 in Table I had double frames, with outside bearings for all axles. The wheel base of Sturrock's Great Northern

¹ Colburn, page 258.

² These include not only the 7ft. 6in. engines mentioned above, but also McConnell's 7ft. "Bloomers."

engine—Fig. 182—18ft. in length, and the position of the leading axle under the middle of the smoke-box, may be noticed. The placing of this axle well forward was also continued during P. Stirling's time. Both the G.N.R. and D. Gooch's G.W.R. standard gauge express engines had

illustrated in Fig. 134 *ante*. The latter lasted about fifteen to eighteen years, whereas the engine now illustrated was in regular service until 1904. The last Midland 2-2-2 engine was built in March, 1866.

2-4-0 *Express Engines*.—Three different types,



FIG. 183—CUDWORTH'S SINGLE DRIVER "MAIL" ENGINE, SOUTH EASTERN RLY., 1861

sandwich frames, though of different designs. Perhaps the most remarkable thing in connection with Gooch's standard gauge engines of the 1862-64 period was the employment of the Stephenson link motion, whilst McConnell, Sinclair and Connor in many of their contemporary express engines used Gooch's valve gear. A possible reason for this difference was that Joseph Armstrong, who then had charge of all the G.W.R. standard gauge engines at Wolverhampton, exercised considerable influence.

Cudworth's 7ft. 2-2-2 "Mail" engines for the South-Eastern Railway—Fig. 183³—had double plate frames and cylinders 17in. by 22in. They were provided with the patent double fire-box, which gave a large grate area of 21.2 square feet. The total heating surface was 1137.9 square feet, and the weight was about 33 tons in working order. For nearly 24 years these engines worked the Dover Mail express trains over

with 6ft. 6in. coupled wheels, may be briefly noted. First a standard express engine, by Sharp, Stewart and Co., 1862-4, for the London, Chatham and Dover Railway.⁴ This railway, which was of later date than other main lines, always employed coupled engines. The outside frames were of iron plates, and Cudworth's long sloping fire-boxes were used, but without the longitudinal partition and double fire-doors. Cylinders, 16½in. by 22in.; wheel base, 14ft. 3in. in the earlier and 14ft. 9in. in the later engines; heating surface, 1065 + 82 = 1147 square feet; grate area, 19.9 square feet; pressure, 120 lb.; the weight empty was 31 tons 18 cwt., of which 21 tons 2 cwt. were carried by the coupled wheels. The arrangement of the balance weights was peculiar, those in the trailing wheels not only being larger than those in the driving wheels, but also placed on the same side as the outside cranks. In the subsequent engines of 1865 for the same

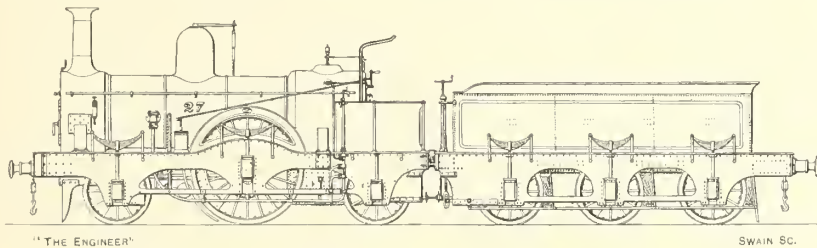

FIG. 184—M. KIRTLEY'S MIDLAND RLY. ENGINE, 1865

a road by no means easy in regard to gradients, with loads which averaged 135 to 140 tons.

The Midland engines are shown by Fig. 184, and the design of slotted-out plate frame, with solid tension members, may be compared with the much weaker sandwich frame with bolted tie bars,

railway, the usual sizes and positions of balance weights were adopted.

The Gooch standard gauge coupled engines, of which eight were built in 1862 by G. England and Co., were used on the northern division of the G.W.R. between Wolverhampton and Chester,

³ See also *THE ENGINEER*, December 24th, 1875, page 441.

⁴ Illustrated in the *Locomotive Magazine*, August, 1902.

where speeds were only moderate. They had the perforated type of sandwich frame, so long associated with the Great Western. Cylinders, 16in. by 24in.; wheels, 4ft. and 6ft. 6in.; wheel

coupled engines. An express engine of 1865 by R. and W. Hawthorn to Fletcher's design had inside bearings only for the coupled wheels, and outside for the leading wheels. The axle guards for the

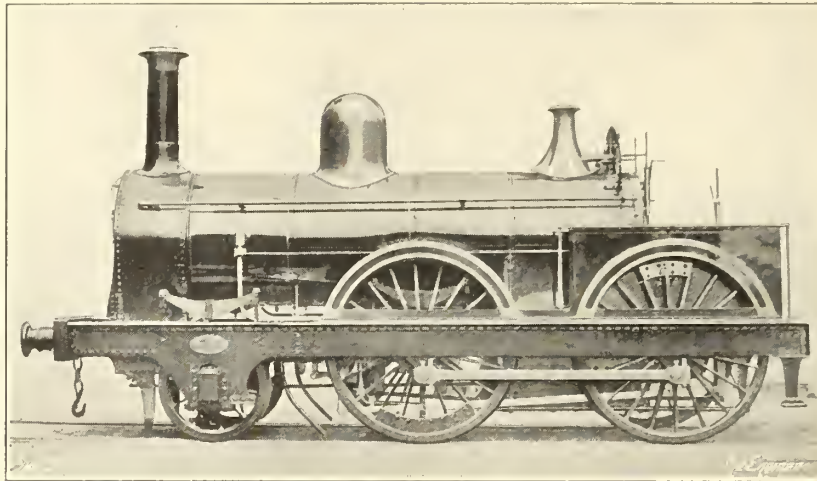

FIG. 185—BEYER, PEACOCK LOCOMOTIVE FOR THE WEST MIDLAND RLY., 1862

base, 16ft., equally divided. The boiler contained 195 2in. tubes, which gave a heating surface of 1091 square feet; total heating surface, 1200.8 square feet. These were the only 6ft. 6in. coupled engines on the G.W.R. standard gauge until 1873, and though of Gooch's design, had Stephenson's link motion. Long "open plate" springs were fitted.

After Joseph Beattie, Edward Fletcher on the

latter were bolted on, and Fletcher did not discard this old-fashioned design until 1870. Cylinders, 16in. by 22in.; wheels, 4ft. 6in. and 6ft. 6in.; wheel base, 16ft., equally divided; heating surface, $1085 + 98 = 1183$ square feet; weight in working order, 34 tons 5 cwt., of which the driving wheels carried 13 tons 17 cwt., and the trailing wheels 10 tons.

A standard 6ft. coupled passenger engine by



Photo. Locomotive

FIG. 186—STEPHENSON'S BOGIE ENGINE FOR THE STOCKTON & DARLINGTON RAILWAY, 1860

North-Eastern Railway was the next engineer to abandon "single" engines completely. Until 1863 the East Coast expresses were worked by 6ft. 6in. single engines, and subsequently by

Beyer, Peacock and Co., in 1862, is shown by Fig. 185. It is characterised by the extreme neatness and symmetry of design. Six of these engines were built for the West Midland Railway (later

G.W.R.), and others were sent abroad. The cylinders were 16in. by 20in.; total heating surface, 1035 square feet; weight loaded, 27 tons. The frames were in one piece from end to end, a design much preferable to the type with bolted on axle guards.

Passenger Engines with Leading Bogies.—A few interesting types with leading bogies made their appearance on British railways during the 1860 to 1865 period. Most of them were designed and built by Messrs. Stephenson, and perhaps it was in accordance with the fitness of events that six of them were for the Stockton and Darlington Railway. The first type consisted of two engines—Fig. 186—built in 1860, with 16in. by 24in.

wheels were necessary, and Colburn describes them as simply “passenger” engines. The bogie wheels were 3ft. 6in. diameter, and to accommodate the horizontal outside cylinders were spaced at 6ft. 1in. centres. The bogie pivot had a spherical upper portion which rested in a socket, through the bottom of which it was prolonged as a stem secured underneath by a nut. This arrangement was similar in principle to D. Gooch’s bogie of 1849. There was no lateral movement of the pivot, and very little clearance between the bogie wheel flanges and the main frames, which were not cut away. The coupled wheel centres were only 7ft. 5in. apart. Total wheel base, 20ft. 0½in.; total heating surface, 1053 square feet;



FIG. 187. STEPHENSON'S BOGIE PASSENGER ENGINE FOR THE STOCKTON & DARLINGTON RLY., 1862 [Photo. Locomotive]

cylinders and 6ft. coupled wheels. The bogie wheels were 3ft. 6in. diameter. The large and roomy American type of cab was a distinguishing feature of these two engines, which were intended for the Barnard Castle and Tebay line over the exposed Pennine hills.

Nevertheless, in spite of the obvious improvement in providing adequate shelter for the enginemmen, the succeeding four engines—Fig. 187—had the then usual form of front weather boards only. These latter engines were also by Stephenson and Co., 1862, and complete drawings were published in Colburn’s “Locomotive Engineering.” They were remarkable in having coupled wheels of the large diameter of 7ft. 0½in., though the cylinders were only 16in. by 24in. They might fairly be termed express engines, but the S. and D.R. had no express trains for which such large

grate area, 12¾ square feet; weight in working order, about 46 tons. A small auxiliary tank for heating the feed water by means of spare steam from the boiler was placed underneath the foot-plate.

Twenty-four remarkable 4-4-0 engines—Fig. 188—were built in 1861-62 for the London, Chatham and Dover Railway by the firms of Hawthorn, Slaughter, and the Canada Works (Birkenhead), to the designs of T. R. Crampton. These, with the exception of six 4-4-0 saddle-tank engines previously mentioned, for the same railway, were the only examples in this country of coupled “Cramptons” with rear driving wheels and cylinders placed near the middle of the engine. The Gooch link motion was placed outside. This was the type of drive afterwards so well known on French railways. The cylinders

were 16in. by 22in., coupled wheels 5ft. 6in. diameter, with compensating levers between their springs. The valves on the top of the cylinders were inclined at about 1 in 9½. The bogie had outside bearings with 3ft. 6in. wheels and only

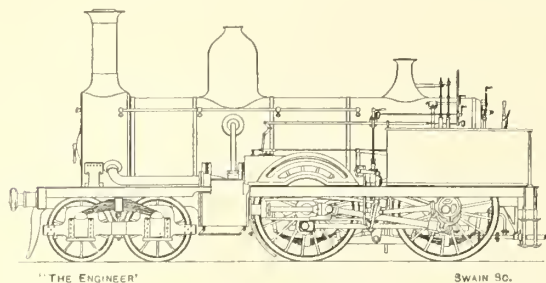

FIG. 188—ENGINE FOR THE L.C. & D. RAILWAY, 1861-62

4ft. wheel base, and had a radiating movement without side play. The steam from the dome was taken by pipes which came out from the sides of the boiler, so that they were exposed only for part of their length instead of wholly, as in the case of the usual French designs. The heating surface was 1200 square feet, of which the long sloping Cudworth fire-box with longitudinal partition provided 130 square feet. The distance from the bogie pin to the front coupled axle was 9ft. 9in. and the total wheel base 18ft. 11in.

This type of engine was not a success on British

years' service the engines had to be scrapped. New 2-4-0 engines with inside cylinders and motion and double frames were designed by William Martley, the locomotive superintendent, and constructed by Sharp, Stewart and Co. in 1864, but the boilers of the "Cramptons" were used for them.

The remaining 4-4-0 engines to be mentioned—Fig. 189—were designed by Edward Fletcher for the Whitby-Malton section of the N.E.R. and built in 1864-65 by Stephenson and Co. The Whitby line is noted for extremely severe curves, and the use of a bogie was a practical necessity, when the time came for replacing the four-wheeled engines which had till then worked the line. The cylinders were 16in. by 22in., the driving wheels 5ft., and the bogie wheels 3ft. diameter. As in most inside-cylinder engines of that period, the bogie pin was placed behind the vertical centre line of the smoke-box. These engines worked on the Whitby line for about twenty-five years.

But the 4-4-0 bogie tender engine had not yet gained a solid footing in this country, and the examples described above were exceptional. It was not until the mid 'seventies that the bogie for passenger tender engines could be truly said to have come to stay. Only on the Great North of Scotland Railway, where it was introduced by Messrs. Stephenson in 1861, did it become standard practice, and from that date no more 2-4-0 engines were built for this line.



FIG. 189—E. FLETCHER'S NORTH-EASTERN RLY. LOCOMOTIVE FOR THE WHITBY LINE, 1864-65

railways. The "Chatham" engines damaged the road severely, and it was stated that one or two accidents were due to their having passed over the line immediately before the trains which came to grief. The result was that after about three

Passenger Tank Engines.—Between 1860 and 1865 several interesting new types of tank engines were constructed, the majority of which embodied flexibility of wheel base. There has always been more scope for variations of tank engine design,

more especially in the wheel arrangements, than in the case of tender engines.

Of the six-wheeled tank engines with rigid wheel base, several railways, such as the Manchester, Sheffield and Lincolnshire, and London, Chatham and Dover, preferred the 2-4-0 type with

tanks were at the back. McConnell's engine—Fig. 191—had 5ft. 6in. coupled wheels, 4ft. trailing wheels, and 15in. by 22in. cylinders. The first five of 1860 had domes, raised fire-box casings, and combustion chambers, but in the last ten of 1862 the domes and combustion chambers were

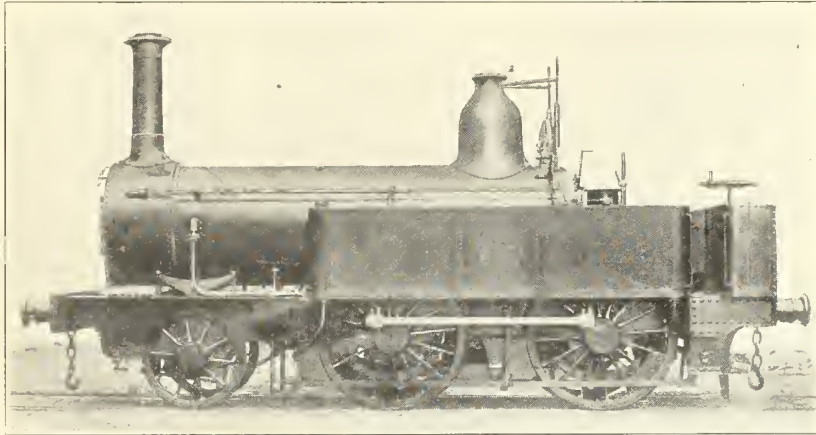

FIG. 190—BEYER, PEACOCK'S TANK ENGINE. WEST MIDLAND RLY., 1861

double frames. In 1861 Beyer, Peacock and Co. introduced the inside-framed engine—Fig. 190. These engines were built by the firm for more than twenty years for branch line traffic on home and foreign railways. The earlier engines had 5ft. coupled wheels, 15in. by 20in. cylinders, and 120 lb. pressure. The latest, in which the dome was placed over the middle of the barrel, had 5ft. 6in. wheels, 16in. by 24in. cylinders, and 140 lb. pressure.

A minority of engineers adopted the 0-4-2 tank

discarded, and the casings were flush, as shown in the illustration. All were built at Wolverton and were the first L. and N.W.R. tank engines to work the local trains in the London district.

An unusual design of 0-4-2 tank engine, shown by Fig. 192, was built in 1859 by Kitson and Hewitson for the Leeds, Bradford and Halifax Junction Railway (afterwards part of the Great Northern Railway). The trailing wheels were the same size as the drivers, *viz.*, 5ft., and from this fact it might be assumed that the engine was intended

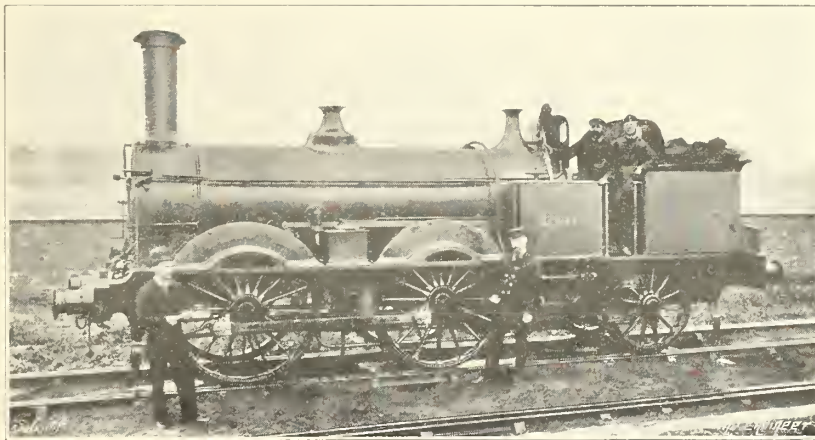

FIG. 191—J. E. McCONNELL'S TANK ENGINE FOR THE L. & N.W. RLY., 1862
(Photo. Locomotive)

engine. Amongst them were McConnell, on the L. and N.W.R. (Southern Division) and Cudworth, on the S.E.R. The former used inside and the latter outside framing, and in both cases the

to be of the six-coupled type, but this was not the case, as there were no crank bosses or crank pins attached to the trailing wheels. No balance weights appear to have been used.

Joseph Beattie's celebrated outside cylinder 2-4-0 well tank engines—Fig. 193—of which there were eighty-five, cannot be passed over. With the exception of three, all were built by Beyer, Peacock and Co. from 1863 to 1875, and until

engines, even with fairly heavy loads. All had Beattie's patented fire-boxes and feed-water heating apparatus. The cylinders were 15½ in. by 20 in. (those built after 1871 16 in. and 16½ in. by 20 in.); wheels, 3 ft. 7¾ in. and 5 ft. 6 in.; wheel



FIG. 192—KITSON'S TANK ENGINE FOR THE LEEDS, BRADFORD & HALIFAX RAILWAY, 1859

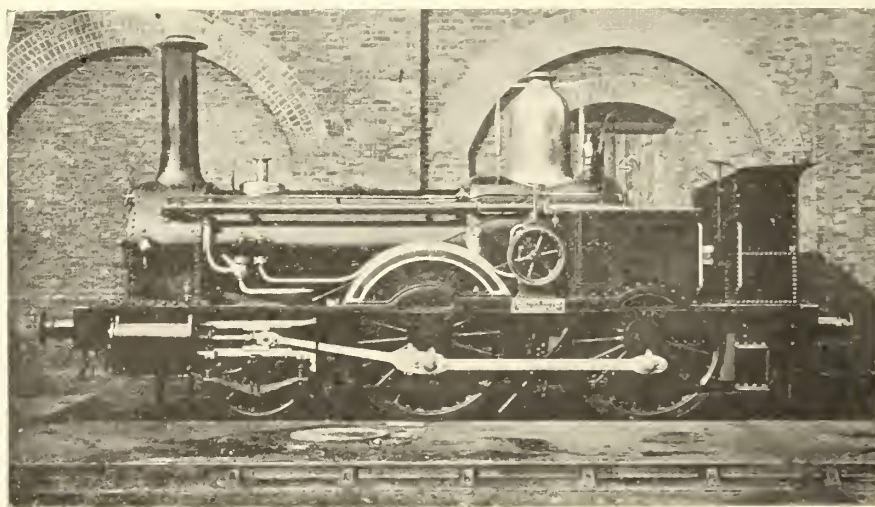

{Photo. Locomotive

FIG. 193—J. BEATTIE'S TANK ENGINE FOR THE L. & S.W. RLY., 1863

about 1890 most of them worked the extensive local traffic in the London area. Although of small size, they were extremely smart and fast-running

base, 5 ft. 6 in. + 7 ft. The boiler, 3 ft. 8 in. diameter inside the smallest ring, contained 224 1½ in. tubes; heating surface: tubes, 858 square

feet; fire-box, 80 square feet; total, 938 square feet; grate, 14.8 square feet; pressure, 130 lb.; weight in working order: leading, 10 tons 10 cwt.; driving, 11 tons 12 cwt.; trailing, 12 tons 7 cwt.; total, 34 tons 9 cwt. A water tank was placed between the frames over the leading axle; another, also between the frames, was under the footplate. The slide valves of the later engines were balanced. All had Allan's straight link motion. Sectional drawings were given in *The Engineer* of February 5th, 1892.

On January 10th, 1863, the Metropolitan Railway was opened between Bishop's-road and Farringdon-street. It was then a broad—7ft.—gauge line, and for some months was worked entirely by the G.W.R. broad gauge tank engines—Fig. 194. These, designed by D. Gooch, were probably amongst the most ungainly and clumsy locomotives of their day. Unlike those of all other G.W.R. broad gauge engines, the cylinders were outside, and owing to the width of the gauge, were spaced at about 8ft. 2½in. centres. In addition, they were somewhat steeply inclined to clear the leading wheels. The outside position of the cylinders was adopted to make room for the tanks and condensing apparatus, of which the flap valves were placed below the smoke-box. The tanks were placed partly under the boiler and partly under the footplate. The latter tank was too far removed from the cylinders, and the tank below the boiler was left to do practically all of the condensing. Flap valves, worked by rods from the footplate, directed the exhaust steam either up the chimney or into the tank under the boiler. The condensing pipe from the right-hand cylinder crossed to the left-hand side of the tank, and that from the left-hand cylinder to the right-hand side, to obtain sufficient length and flexibility. They were prolonged within the tank, being perforated with holes to distribute the exhaust steam. The arrangement was defective, since the placing of condensing pipes below the water level and the production of a vacuum in them when steam was shut off resulted in the risk of drawing water into the cylinders. To prevent

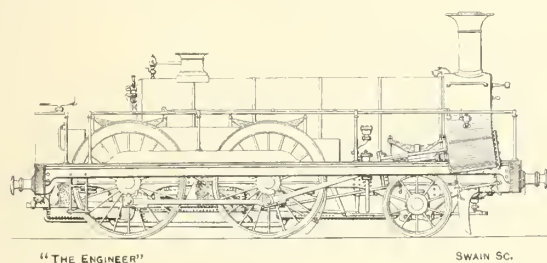

FIG. 194—D. GOOCH'S BROAD GAUGE METROPOLITAN SERVICE TANK ENGINE FOR THE G.W. RLY., 1862

such a mishap additional automatic flap valves were placed in the exhaust pipes, but there was much difficulty in keeping them water-tight. Stated briefly, when the pipes and connections

were not engaged in sucking air from the outside, they were busily employed in allowing water to leak out from the inside. The tanks had insufficient capacity, got overheated, and the chimney exhaust had to be resorted to in the tunnels.

These engines had 16in. by 24in. cylinders, 6ft. coupled wheels, and a rigid wheel base 8ft. +

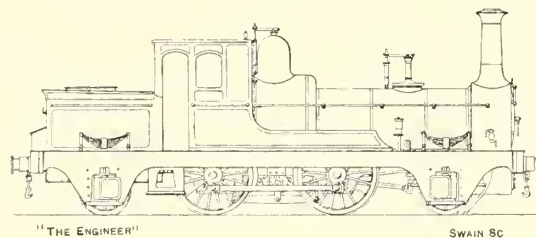

FIG. 195—CROSS & CO.'S "WHITE RAVEN," FOR THE ST. HELENS RLY., 1863

7ft. 6in. There were 22 of them, of which six were built by the Vulcan Foundry, 1862; six by Kitson, 1863, and the remainder at Swindon in 1863-64. They were the first condensing tank engines to be put into service. There were also two similar standard gauge engines, built at Swindon in 1864, with 5ft. 6in. coupled wheels and 15in. by 24in. cylinders. Some of them were converted to 2-4-0 tender engines and the condensing gear removed, after which they lumbered along for a few years between London, Windsor, and Reading.

The addition of arrangements for making the wheel base flexible was the cause of a large increase in the number of eight-wheeled tank engines.

The 2-4-2 radial tank engine first appeared in November, 1863, and was provided with W. Bridges Adams's radial axle-boxes at both ends. This engine, the "White Raven" (Fig. 195) was built by Cross and Co., St. Helens, for the St. Helens Railway, but before being placed in regular service was tried on the North London Railway. In addition to the radial axle-boxes, the engine was fitted with the Adams patented spring tires. Between the rim of the wheel and the tire, which was of Krupp steel, a steel hoop spring was placed round the wheel, with the object of making the tire fit the wheel elastically, being neither too loose nor too tight. Mr. Adams considered this the safest form of tire, as it had no tendency to burst; it had sufficient yield to minimise the effect of blows, and was pliant enough to cause better adhesion between tire and rail.⁵

The "White Raven" had 15in. by 20in. cylinders, coupled wheels, 5ft. 1in. diameter; radial wheels, 3ft. 3in. leading and 3ft. 1in. trailing; wheel base, 7ft. + 8ft. + 7ft. = 22ft.; heating surface, 687 square feet; pressure, 140 lb.; capacity of tanks, 950 gallons; coal capacity, 25 cwt.; weight loaded: leading, 7 tons 15 cwt.;

⁵ See "Proc." Inst. C.E., Vol. 23, 1863-64; also Colburn's "Locomotive Engineering," pages 276-278, where a full description of this engine is given.

driving, 11 tons 15 cwt.; coupled, 11 tons 5 cwt.; trailing, 10 tons; total, 40 tons 15 cwt.

Since the radial axles were the principal feature, some particulars of them are given. The first idea of a radial axle appears to have originated with the French engineer, Edmond Roy, in 1857, but the arrangement was defective. At the same time a Mr. Strong, of the Caledonian Railway, proposed what was in most respects a similar idea to that subsequently adopted by Adams, but had straight instead of curved guides. It was mechanically defective in that the axle-boxes would have had to be slack in the guides. Nevertheless, some shunting engines with this arrangement were built in Germany, even after Adams's much improved axle-boxes had appeared.

Unlike the radial axle-boxes, the patent spring tires did not meet with extended application, and appear to have been soon discarded.

In 1864 Robert Sinclair designed the 2-4-2 tank engine shown in Fig. 196, of which twenty were built by Neilson and Co. for the Great Eastern Railway to work local trains in the London area and country branches. They differed from the "White Raven" in that the leading axle formed part of a Bissell truck, but the trailing axle was rigid. In this and other respects their design followed that of the 2-4-2 tender engine, built by Messrs. Stephenson for the Luxembourg Railway in 1860 to Sinclair's general instructions—Fig. 169 *ante*.

The pin of the Bissell was attached to the boiler

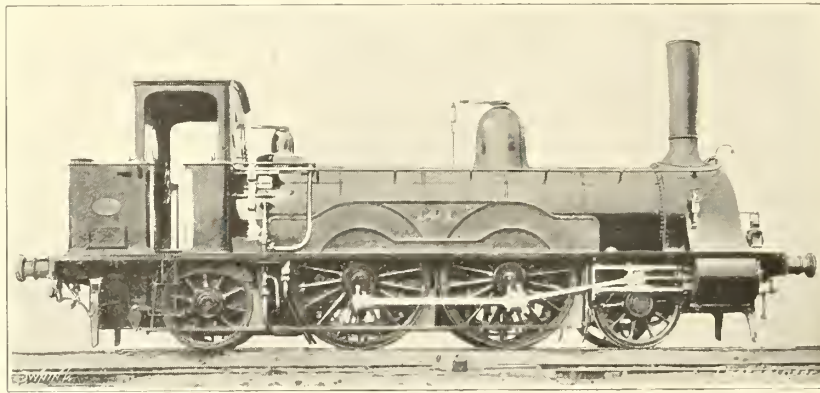

[Photo. Locomotive

FIG. 196—SINCLAIR'S TANK ENGINE FOR THE GREAT EASTERN RAILWAY, 1864

In Adams's patent of 1863 the axle-box itself was made with curved sides which worked inside corresponding curved guides on the horncheeks. The outside journals were each made with a central collar which worked inside a corresponding recess in the brass, and the lateral movement of the axle was transmitted to the axle-box through the collar and brass. In the "White Raven" each radial axle-box had a lateral movement of $4\frac{1}{2}$ in. each side, and the radii of curvature were struck from the centre of the nearest coupled axle, in this case 7 ft. distant. One thing was lacking, viz.: the employment of some form of controlling arrangement, and neither spring control nor inclined planes were used with these early axle-boxes. The result was that the engine was too flexible, with a tendency to excessive lateral oscillation. The "White Raven" came into possession of the L. and N.W. Railway when the latter absorbed the St. Helens Railway in 1867, and a few years afterwards the radial axle-boxes were removed, and the engine was converted into a 2-4-0 tender engine with rigid leading axle. Nevertheless, Adams's system was the origin from which all modern forms of radial axles, including the Webb type, have been derived, and on the Continent of Europe such axles are to this day termed "Adams axles."

through the intermediary of cross plates and angle irons. To transmit the weight of the truck a hemispherical pivot, $6\frac{1}{2}$ in. diameter, was fixed to the barrel about 1 in. in front of the leading wheels and fitted into a corresponding recess in a transverse cast iron girder. At each end of and forming part of this girder were double inclined planes, which rested upon corresponding planes of steel fixed on the transverse plate of the truck. When the engines were new the planes were inclined at 1 in 6, and had a tendency, when returning to the central position, to come down with a slam. The incline was afterwards reduced to 1 in 24, and the amount of lateral movement was increased from 1 in. to $1\frac{1}{2}$ in. on each side. The length of radial arm was 4 ft. 2 in.

The cylinders, 15 in. by 22 in., were outside, as in all Sinclair's engines. Coupled wheels, 5 ft. 7 in., carrying wheels, 3 ft. $7\frac{1}{4}$ in. diameter; wheel base, 5 ft. 4 in. + 6 ft. = 17 ft. 4 in.; overhang of frames at each end, 5 ft. 9 in.; boiler barrel, 13 ft. 6 in. long by 3 ft. 11 in. diameter outside; heating surface, of 143 $1\frac{1}{2}$ in. tubes, 966 square feet; total, 1034 $\frac{3}{4}$ square feet; pressure, 120 lb.; weight in working order, leading, 8 tons 7 cwt.; driving, 9 tons 14 cwt.; coupled, 9 tons 4 cwt.; trailing, 9 tons $1\frac{1}{4}$ cwt.; total, 36 tons $6\frac{1}{4}$ cwt.

Radial axles were not, however, confined to eight-wheeled tank engines, and in 1864-66 A. Sturrock designed some 0-4-2 back tank engines in which the trailing axles were provided with Adams's radial axles. All the bearings were outside, and the main frames were of the sandwich

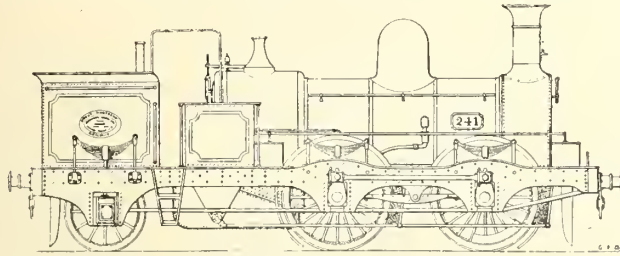

FIG. 197—A STURROCK'S TANK ENGINE FOR THE G.N.R., BUILT BY THE AVONSIDE ENGINE CO., 1865

pattern which Sturrock used for all his engines. There were twenty of these engines, fifteen by the Avonside Engine Company and five by Neilson on the Great Northern Railway, and fourteen more by Neilson on the London, Chatham and Dover Railway. The G.N.R. engines, one of which is illustrated in Fig. 197, had domes on the middle of the boiler, but in the Chatham engines—Fig. 198—they were placed on the front ring.

The cylinders were 16½ in. by 22 in.; coupled wheels, 5 ft. 6 in.; and the trailing wheels, 4 ft. diameter. The Chatham engines of 1866 had 183 brass tubes 2 in. diameter in a boiler barrel 4 ft. 1½ in. diameter outside. Their total weight in working order was:—Leading, 13 tons; driving, 14 tons 2 cwt.; trailing, 14 tons 5 cwt.; total, 41 tons 7 cwt.

The wheel bases differed. That of the first ten G.N.R. and of the L.C.D.R. engines was 7 ft. 6 in. + 11 ft. 9 in., but in the second ten G.N.R. engines

bearings were 16 in. by 6 in. diameter, with central collars 7½ in. diameter by 2 in. wide, and the main bearings also had central collars. The tops of the radial axle-boxes were flat, and the spring pillars had sliding brass shoes. The lateral movement was 2½ in. each side, but there was no controlling force.

These were excellent engines and performed a vast amount of hard work for many years. Their fault was considerable oscillation at the trailing end at high speeds, owing to the great length of wheel base between the driving and radial axles, and absence of controlling force. This oscillation was transferred to the front van or coach of the train, in which the movement was sometimes very uncomfortable.

The 4-4-0 outside cylinder engines—Fig. 199—of the Metropolitan Railway, by Beyer, Peacock and Co., 1864, remain to be described. They were not the first of the type, since the same firm had built eight very similar, but smaller, engines for the Tudela and Bilbao Railway, Spain, in 1862. The four-wheeled leading truck was on the Bissell system, and in the Metropolitan engines was pivoted 6 ft. 8 in. behind its centre line. The wheel base of the truck was 4 ft.; that of the coupled wheels, 8 ft. 10 in.; total base, 20 ft. 9 in.; the cylinders were 17 in. by 24 in., and to clear the truck, were placed at a considerable inclination; diameter of coupled wheels, 5 ft. 9 in.; and of truck wheels, 3 ft.; the tires were of Krupp steel; the boiler, 4 ft. diameter inside the smallest ring, contained 166 2 in. tubes, which provided 912.6 square feet of heating surface, to which the fire-box added 101.2 square feet; pressure, 130 lb.; tank capacity, 1000 gallons; weight in working order: truck 11 tons 3½ cwt., driving 15 tons 9½ cwt., trailing 15 tons 10 cwt., total 42 tons 3 cwt.; weight empty, 35 tons 8¾ cwt.

The principal feature was the condensing appa-



FIG. 198—L.C. & D. RAILWAY TANK ENGINE, 1866

[Photo. Locomotive]

was 12 ft. 9 in. between driving and trailing wheels. The radii of curvature of the centre lines of the axle-boxes were 7 ft. 9 in. and 8 ft. 6 in. for the two engines respectively. The radial axle-box

ratus for use in the tunnels. The exhaust steam was "shunted" from the blast pipe into a large pipe, entering the top of the tank, and was discharged upon the surface of the water. The result

was that the upper portion only of the water in the tank was heated, as there was no circulation. A smaller pipe with open upper end was then added. This end entered the mouthpiece of the larger pipe for a short distance, and the lower

and most, if not all, of the older engines were altered to this system. The wheel base of the bogie remained 4ft., as in the earlier engines. That the original design, in spite of the large coupled wheels, proved extremely satisfactory, is

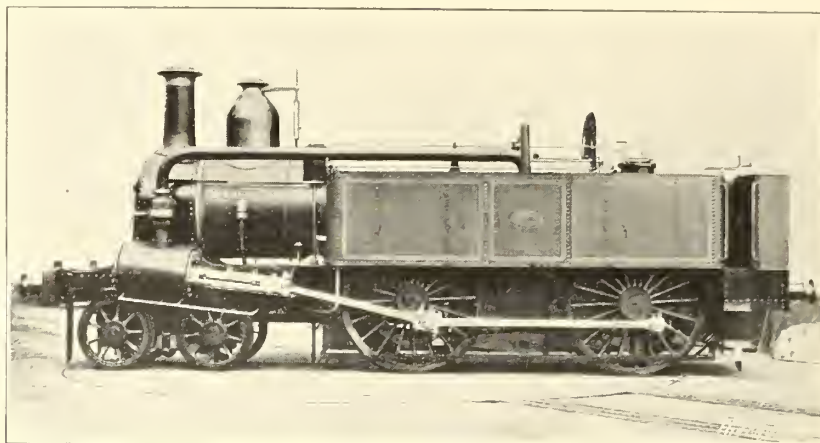

FIG. 199—BEYER, PEACOCK'S METROPOLITAN RLY. TANK ENGINE, 1864

end, also open, dipped into the tank. The greater part of the steam found an exit through the annular space between the pipes, and played upon the surface of the water, but sufficient steam passed into the small pipe and caused circulation of the water. The tank capacity of the later engines of 1879 to 1884 was enlarged to about 1140 gallons, and the weight in working order increased to 46 $\frac{3}{4}$ tons, of which the driving wheels carried 18 tons 18 cwt., and the trailing wheels 17 tons 18 cwt.

borne out by the fact that Beyer, Peacock built no less than 148 of these engines, of which 120 were in use on the Metropolitan and the District railways. The L. and N.W.R., Midland and L. and S.W.R. had twenty-eight between them. Five others were built in 1871 for the Rhenish Railway (Germany). The last of the type were delivered to the Met. District Railway in 1886. A complete list of detailed dimensions of the later engines was given in *The Engineer*, May 17th, 1889, page 415.

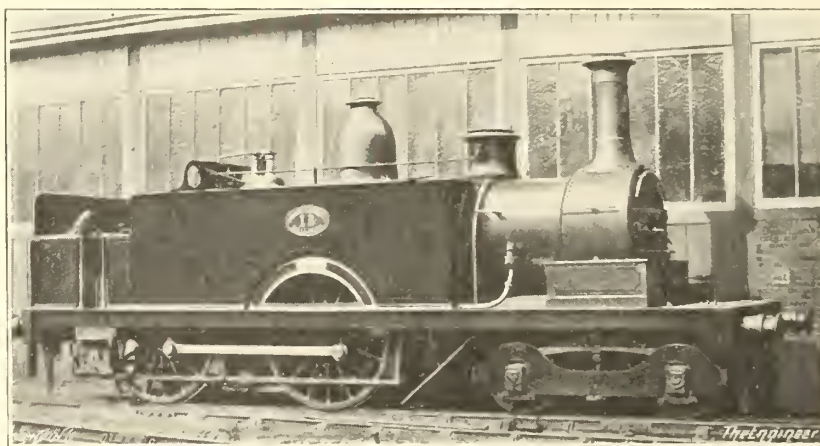

FIG. 200—W. ADAMS'S TANK ENGINE FOR THE NORTH LONDON RLY., 1863

The four-wheeled Bissell bogie truck appears to have left something to be desired. The engines built between 1864 and 1871 were provided with it, but in those from 1879 onwards an Adams sliding bogie, with central pivot, was substituted,

The original No. 1 of 1864 ran 632,145 miles before being re-boilered in 1887. The original boilers were of Yorkshire iron. No. 1 was also the first to be broken up, as the result of an accident in 1897, and then had 1,050,000 miles to her credit.

The handsome 4-4-0 side tank engines—Fig. 200—were built at the Bow Works of the North London Railway between 1863 and 1869, to the designs of William Adams, following the general lines of Stephenson's tank engines of 1855 for the same railway, but the bogie was of a much improved type, with longer wheel base. The engines of 1865 and later, of which the illustration shows one, were considerably larger and the bogies were the first to be provided with lateral traverse for the pivot. The bogie frames were outside, 6ft. 6in. apart, and connected transversely at the middle by two channel irons faced with steel on their upper sides. The pivot, 6in. diameter, passed through a bush arranged to slide laterally on the steel faces, with a traverse of 4½ in. each side, but in the first engines there was no controlling force. Soon afterwards india-rubber side check springs were added. The bogie wheel base was 6ft. A single inverted spring took the load on each side. All axles and tires were of steel. The coupling rods were of Bessemer steel and in the engines built from the beginning of 1866 were made with Ramsbottom's bushed ends, for which Adams used cast iron bushes lined with white metal. As compensating levers were placed between the springs of the coupled wheels, the spring-borne weight was carried on three points, a system to which Adams consistently adhered for many years.

The inside cylinders, 17in. by 24in., were inclined at 1 in 18, and placed at 2ft. 4in. centres; coupled wheels, 5ft. 9in. diameter (increased subsequently to 5ft. 11in. with thicker tires); bogie wheels, 3ft. diameter; wheel base, 6ft. + 8ft. 2in. + 8ft. = 22ft. 2in.; the boiler, 11ft. 8in. long by 4ft. 1in. diameter, contained 120 brass tubes, 2½ in. diameter; heating surface of tubes, 846 square feet; of fire-box, 112 square feet; total, 958 square feet; grate area, 16½ square feet; total weight in working order, about 42 tons, of which

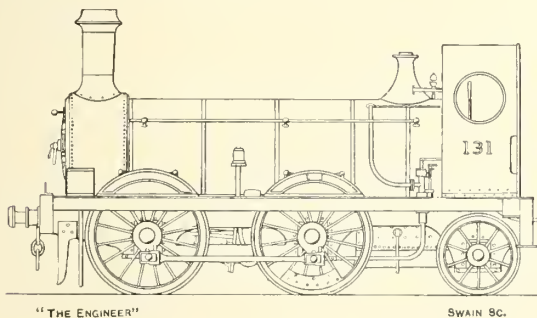

FIG. 201—P. STIRLING'S GOODS ENGINE, G. & S.W. RLY., 1864

30 tons were available for adhesion. The high boiler pressure of 160 lb. was carried.

Four-wheels Coupled Goods Engines.—The last of Bury's type of 0-4-0 engines with bar frames was built for the Furness Railway in 1861 by W. Fairbairn and Sons, who still adhered to

this design after the disappearance of the firm of Bury, Curtis and Kennedy. A more modern type of 0-4-0 engine for use on mineral branch lines was subsequently built by Sharp, Stewart and Co. for the same railway, and by P. Stirling at Kilmarnock Works for the Glasgow and South-Western Railway. These engines had plate frames, and, unlike the Bury and Fairbairn engines, had cylinders inclined downwards towards the back with slide bars above the leading axle.

Some 0-4-2 engines of excellent design were built, 1859 to 1864, mostly by Beyer, Peacock and Co., for the Edinburgh and Glasgow Railway. In them the small trailing wheels had outside bearings to keep the journals away from the heat of the fire-box. These engines, which had 5ft. wheels and 16in. by 22in. cylinders, were in service for about forty-five years.

P. Stirling's 0-4-2 goods engines, built by R. and W. Hawthorn, 1864, for the Glasgow and South-Western Railway, are shown in Fig. 201, and were the first in which the well-known Stirling external characteristics made their appearance. The domeless boiler had Hawthorn's perforated steam pipe. Stirling's first domeless engines of 1860, built by Sharp, Stewart and Co., were arranged differently. The internal steam pipe had eight short vertical tubes, each 1in. diameter, fixed in the upper side immediately beneath the safety valve casing above the fire-box. The upper ends of these short tubes were open to admit steam to the main pipe. These earlier engines were without cabs. In the engines illustrated, the regulator was of the gridiron slide type, placed in the smoke-box with a double-armed vertical pull-out handle. The trailing end was carried on a single laminated transverse spring. The tires of the coupled wheels were of steel, but those of the trailing wheels were of wrought iron. There was one pump and one injector. The cylinders were 16in. by 22in.; coupled wheels, 5ft.; and trailing wheels, 3ft. 6in. diameter; the boiler contained 162 2in. tubes, pitched at 2½ in. centres; heating surface of tubes, 852 square feet; of fire-box, 78 square feet; total, 930 square feet; pressure, 120 lb. per square inch.

Six-coupled Goods Engines.—Fig. 202 shows the engine sent by Sharp, Stewart and Co. to the London Exhibition of 1862, and afterwards exported to Egypt. Six similar engines were built for the London, Chatham and Dover Railway. It is illustrated to show the solid slotted-out outside plate frames, a design immediately afterwards adopted by M. Kirtley on the Midland Railway. The inside frames extended from front to back buffer beams, whereas in Kirtley's engines of 1863-65 they stopped short at the fire-box, and retained the old defect of causing the draw-bar pull to be retained through the latter.

Sharp's engine had 17in. by 24in. cylinders, 5ft. wheels, and 120 lb. pressure; wheel base, 15ft. 6in., equally divided. The fire-box was of

the Cudworth type, with long sloping grate and two fire-doors; grate area, 27.5 square feet; total heating surface, 1192 square feet; weight of engine in working order, 32 tons.

constructed by other firms and at Gateshead Works.

An extraordinary type of six-coupled tender engine, considering the period when it was built,

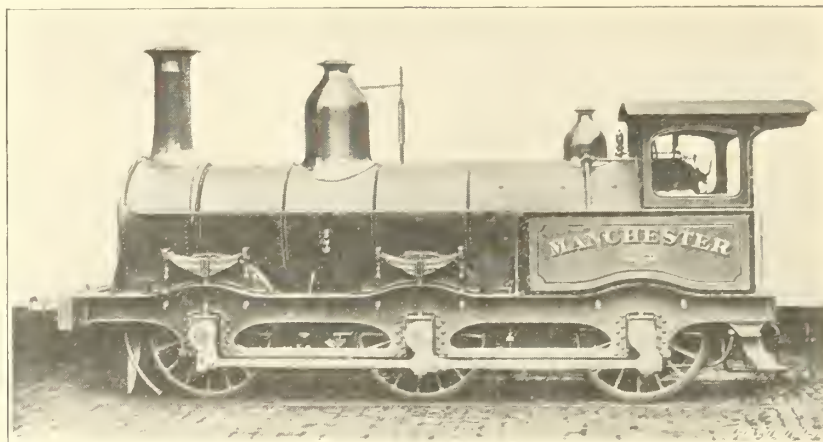

FIG. 202—GOODS ENGINE FOR EGYPT BY SHARP, STEWART & CO., 1862

One of Kirtley's Midland engines of the 1863-69 period, with 5ft. 2in. wheels and 16½in. by 24in. cylinders, is illustrated in Fig. 203. From 1860 onwards the Midland engines carried 140 lb. pressure.

A large number of the North-Eastern six-coupled engines of E. Fletcher's designs had double frames and all wheels in front of the fire-box. They had 5ft. wheels, 16in. by 24in. cylinders and 130 lb. pressure. They were intended for long-distance coal trains, but despite the short wheel base were very frequently to be seen on fast main-line goods trains. The outside

is that shown in Fig. 204. It was supplied to the Llanelly Railway by Messrs. Fossick and Hackworth, of Stockton, in 1864 (not 1844 as was erroneously given in J. Tomlinson's address before the Institution of Mechanical Engineers in 1890). The Hackworth, who was a member of this firm, was Thomas, the brother of Timothy, and the engine illustrated was the last design of the Hackworth school, in so far as the steeply inclined cylinders attached to the smoke-box were concerned. The long connecting-rod which drove the trailing wheels, and the rectangular steam chest above the cylinders with very long valve

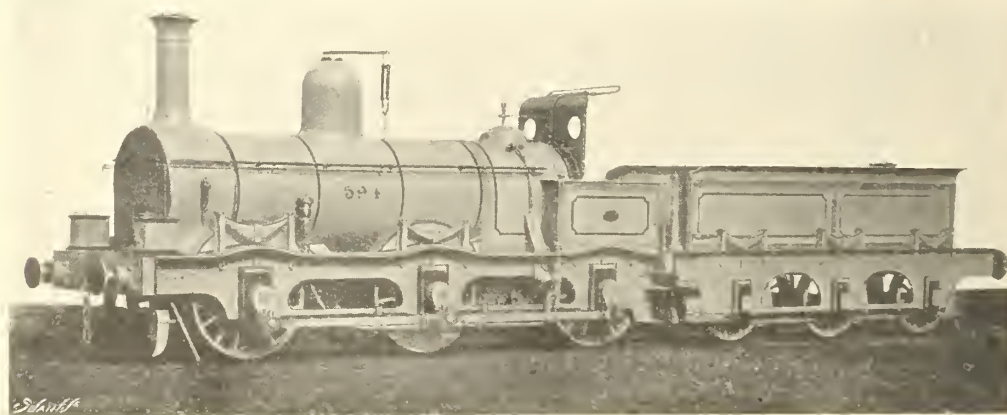

FIG. 203—M. KIRTLLEY'S GOODS ENGINE FOR THE MIDLAND RAILWAY, 1863-69

framing was of the then somewhat antiquated type, with horn-plates bolted on. The majority of these engines were built by Hawthorn and Stephenson, 1860 to 1866, and a number were also

rods, were amongst the peculiar features of this engine. The valve motion appeared to be a form of John W. Hackworth's radial gear, according to the writer's recollection, but unfortunately no

sketch of it was made which could definitely settle this point. The engine was preserved for many years at Swindon as a curiosity. It had 16in. by 24in. cylinders and 4ft. 6in. wheels.

Tank Engines for Steep Gradients.—For the Lickey incline on the Midland Railway, M.

built by the same firm in 1866 for the Great Northern Railway, on which line they were employed in the King's Cross goods yard, and in working through the Metropolitan tunnels. For this service the latter engines were fitted with condensing apparatus. The cylinders were 18½in.

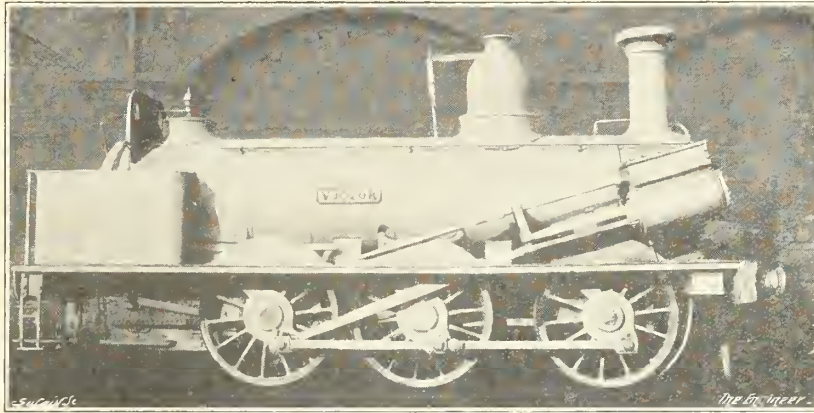

[Photo. Locomotive

FIG. 204—FOSSICK AND HACKWORTH'S GOODS ENGINE FOR THE LLANELLY RLY., 1864

Kirtley in 1860-63 built some 0-6-0 back tank engines with double frames. The design was generally similar to that of the tender goods engines, but the coupled wheels were only 4ft. 2in. diameter. The inside cylinders were 16½in. by 24in.; pressure, 140 lb. per square inch; and the weight in working order, 35 tons. They were tested, unbanked, with a load of 140 tons up the two miles of 1 in 37.

Similar engines were designed by Joseph Tomlinson for banking on the Navigation incline of the Taff Vale Railway, on which the gradient was 1 in 20. These engines, which were built by Sharp, Stewart and Co., 1865-67, had saddle tanks, 16in. by 24in. cylinders, 4ft. wheels, and 130 lb. pressure.

Eight-wheels Coupled Tank Engines.—The two most powerful tank engines in this country were to be found on the Vale of Neath Railway.

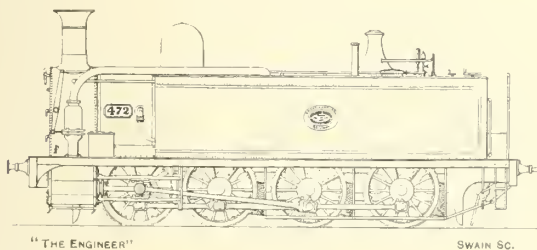

FIG. 205—TANK ENGINE FOR THE GREAT NORTHERN RLY. BY THE AVONSIDE CO., 1866

They had eight coupled wheels and outside cylinders, and were built in 1864 by the Avonside Engine Company, of Bristol. The illustration—Fig. 205—shows one of two very similar engines

by 24in., and the diameter of the wheels 4ft. 6in.; the wheel base of the Vale of Neath engines was 4ft. 10in. + 4ft. 10in. + 5ft. 7in. = 15ft. 3in., and the side tanks were considerably shorter than those of the G.N.R. engines. The latter had a wheel base of 15ft. 10in., the distance between the centres of the second and third pairs of wheels being increased to 5ft. 5in. The boiler barrel of the V. of N. Rly. engines was 13ft. 1½in. long by 4ft. 2¾in. diameter inside at the front ring, and 4ft. 5in. diameter at the back ring; fire-box casing, 7ft. long by 3ft. 10in. wide; 203 ¼in. tubes gave a heating surface of 1588 square feet, to which the fire-box added 155 square feet; total, 1743 square feet; grate area, 23.8 square feet; pressure, 140 lb. The G.N.R. engines had longer boilers and shorter fire-boxes, and the number of tubes was reduced to 184 2½in. diameter. The total heating surface was 1550 square feet.

The fire-boxes had longitudinal partitions and transversely placed roof girder stays. The cylinders were spaced with centres 6ft. 9½in. apart, and the steam chests were let through holes in the frames. Gooch's stationary link motion was used, the links being placed in front of the second axle, the excentric rods passing one above and the other below this axle. The radius rod passed below the leading axle, and was deeply cranked to clear it. The connecting-rods were 9ft. 5in. long. The total weight of the engines was 56 tons.

The tires of all wheels had flanges, but the leading and trailing axle-boxes had a lateral movement in the guides of ½in. on each side, controlled by a special arrangement of check springs, the invention of M. Caillet, a French engineer, which will be described subsequently.

Whether these were the earliest eight-coupled

engines actually used in this country is not quite certain. Clark ("Railway Machinery," 1855) shows a diagram of an eight-wheels coupled tender engine by Stubbs, of Llanelly, with 3ft. wheels and 9ft. 6in. wheel base, but gives no information beyond stating that it was designed to run on mineral lines in Wales. The writer has not been able to trace this engine, which, if it ever got beyond the stage of a design only, must have been built between 1850 and 1853. There was another eight-coupled tank engine, with 20in. by 24in. cylinders and 4ft. 9in. wheels, on the Llanelly Railway, stated to have been built in 1865. Including it, but exclusive of the engine shown by Clark, the above five tank engines were the only representatives of the eight-coupled type on British railways for many years, and all were scrapped before the end of 1880.

tried experimentally in 1863, and a considerable number were built in 1864-66, but P. Stirling, who succeeded Sturrock on the G.N.R. in 1866, shortly afterwards converted them to ordinary tenders. The Manchester, Sheffield and Lincolnshire Railway also had a number, which met with a similar fate.

Sturrock was not the first engineer to adopt a steam tender, the credit for which was due to M. Verpillieux, who constructed one in 1843 for the Lyons and St. Etienne Railway.

The Fairlie double bogie tank locomotive and the Fell central rail engine also made their first appearance during this period. Engines of these types will be considered later.

Frames.—It is unnecessary to add much to the particulars already given, beyond pointing out that solid plate frames were still welded, and the



[Photo. Locomotive

FIG. 206—A. STURROCK'S STEAM TENDER LOCOMOTIVE, G.N.R., 1863

Sturrock's Steam Tenders.—A full account of these tenders with drawings and complete specification, appeared in *The Engineer*, January 17th and May 9th, 1919, to which readers may be referred for fuller particulars. Fig. 206 shows one of the steam tender locomotives on the Great Northern Railway. The six wheels of the tender were coupled through outside cranks, and two 12in. by 17in. inside cylinders were placed underneath at the front end, the middle axle being cranked to take the drive. Stephenson's link motion was fitted. Steam from the boiler of the locomotive was taken from a second regulator in the dome through an external pipe to the tender, and probably had a considerable percentage of moisture in it by the time that it reached the tender cylinders. The exhaust passed into a tubular condenser in the bottom of the tender, and heated the feed water, after which it made its exit to the atmosphere through a short chimney at the back. The engines fitted with these tenders were capable of hauling heavy coal trains between Doncaster and London, *via* Lincoln, but burnt a large amount of fuel. There was also the difficulty of maintaining steam in a boiler of moderate dimensions. The drivers were stated to have disliked them exceedingly, as they had the equivalent of two engines to look after, and the heat on the footplate was excessive. These tenders were first

time for slotting them out of a solid rolled plate had not yet arrived.

The method of securing outside cylinders to the main frames by deepening the latter and slotting an aperture through which the steam chests passed was used by Sinclair from the end of 1859, though it had been introduced by Allan on the Scottish Central Railway in 1856. The steam chests were fitted to the frames by ribs, and a connection was made across the engine by a box either of plates and angles or in later engines by flanged castings.

Radial and Other Axle-boxes with Lateral Movement.—Whether, following Roy's 1857 design, W. Bridges Adams was the next to invent a radial axle, in 1863, is uncertain, since a prior claim has been made on behalf of Wöhler,⁶ locomotive superintendent of the Lower Silesian Railway, whose name is so well known in connection with the classic experiments on repetition of stress. But the date of Wöhler's radial axle-box is doubtful, and the writer cannot trace an engine so fitted before 1865. Wöhler, however, arranged for a controlling force by means of a special spring pillar with a loose cam-shaped piece between it and the axle-box, such that the pressure of the spring caused the box to return to its mid

⁶ Heusinger v. Waldegg, "Handbuch für Spezielle Eisenbahn Technik."

position. Adams's early radial axle-boxes had no controlling force, with the result that on straight track there was considerable lateral oscillation of the radial axle. The idea of a controlling force was suggested in 1864⁷ by G. H. Phipps, who proposed a plate spring perpendicular

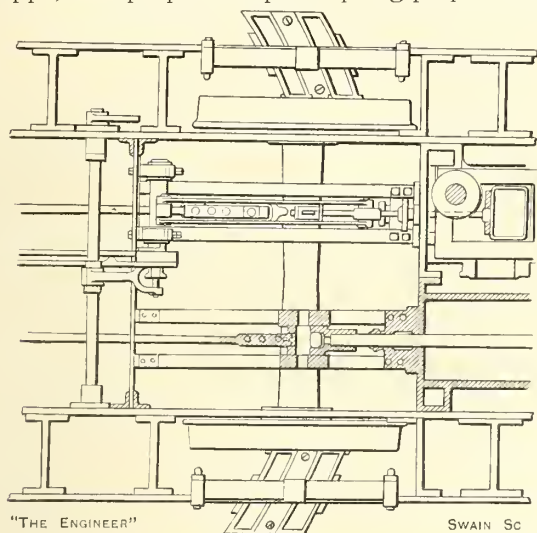

FIG. 207—W. BRIDGES ADAMS'S RADIAL AXLE, 1863

to the axle and pressing against the collar of the journal. Phipps's suggestion was afterwards carried out in a modified form by Webb and others.

The original form of Adams's axle-box which had a central collar on the journal is shown by Fig. 207.

The length allowed for the radius of curvature of these early axle-boxes and Bissell trucks is of interest, and the three types of engine already described may be compared. In the "White Raven," the first engine built, which was of the 2-4-2 type, a_1 and a_2 —Fig. 208—were equal, and the rigid wheel base was equal to b . The radius of curvature at each end was equal to a_1 or a_2 . There was no apparent reason for this dimension, which seems to have been tentative. Subsequently W. B. Adams made some experiments on the North London Railway, the details of which have not been left on record; but he arrived at the conclusion that the centre of the radius should be midway between the radial axle and a point half-way between the centres of the rigid axes,

that is $r = \frac{a + \frac{b}{2}}{2}$ The radius for the 0-4-2 tank

engines of the L.C. and D.R. was calculated in this way. That of the G.N.R. engines, in which a was 1ft. longer, should by this rule have been 8ft. 3in., but was made 8ft. 6in. In the case of the Great Eastern 2-4-2 tank engines the same rule was used, and it seems to have been the original

⁷ "Proc." Inst. C.E., Vol. 23, 1864.

intention to employ it in the G.E.R. engines for Bissell trucks at both ends, but as built the trailing axle was fixed, so that the rigid wheel base was $b + a_2$. In spite of this change no alteration was made in the length of the radial arm at the leading end.

Baldry's later rule, derived mathematically from Euclid III. 36, may be most simply expressed $r = \frac{a(a+b)}{2a+b}$, a value which is less than that given by Adams's rule by an amount equal to

$\frac{4}{4(2a+b)}$. Baldry's rule makes no allowance for flange clearances, and the length of radial arm derived from it should be lengthened to maintain the flange of the radial wheel against the outer rail and so prevent "hunting" of the axle from side to side. Taking these points into consideration, it will be found that Adams's old empirical rule gives results not far from those used in the best practice of to-day, except in the case of 2-4-2 tank engines.

The parallel end axles of the eight wheels coupled tank engines of the Vale of Neath Railway were provided with the somewhat complicated controlling arrangement shown by Fig. 209, the invention of M. Caillet, and patented in this country by Mr. Slaughter, of the Avonside Engine Company. Two laminated controlling springs were mounted on a transverse rod, the ends of which were extended to enter freely into recesses in the bearing spring pillars. On to these extensions forked brackets were screwed, the outer ends of which abutted against the sides of the bearing spring pillars, the inner ends bearing on the extremities of the laminated controlling springs. Nuts at each side could be screwed up to give an initial controlling force. In mid-position the outer ends of the forked brackets did not exert any pressure against the vertical spring pillars. The latter had rounded ends which fitted into recesses

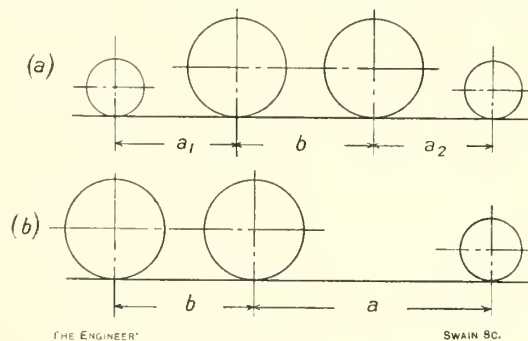

FIG. 208

in loose pieces sliding on the tops of the axle-boxes. The lateral movement of the axle-boxes was allowed for by making their width between flanges greater than the faces of the horncheeks. When the axle was displaced laterally on a curve the axle-boxes moved underneath the surfaces of

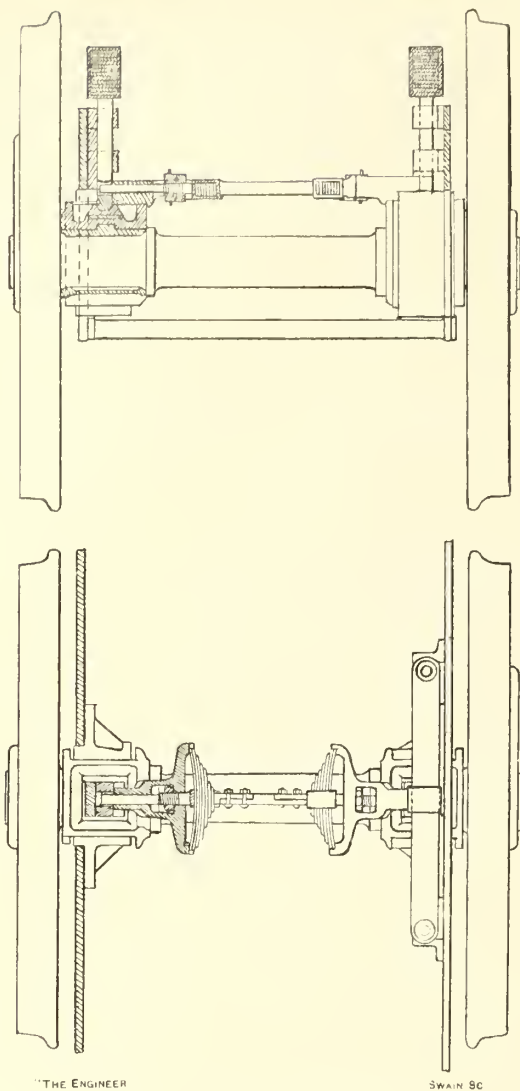

FIG. 209—CAILLET'S MOVABLE AXLE

the pieces below the spring pillars, moving the forked bracket, and compressing the controlling springs. No movement took place until the initial controlling force was overcome. The initial resistance offered by the check springs was 24 cwt. The arrangement proved defective in that the force due to the check springs was transmitted to the engine frames in such a way that the latter, not being sufficiently stiff, bent outwards, and the transmission through the vertical spring pillars was also mechanically defective. The arrangement is interesting in that it was the earliest case in which check springs appear to have been actually used.

Bogies.—In 1865 we meet with the first tender engines having four-wheeled bogies, with lateral movement of the pivot, in six 4-4-0 engines with outside cylinders, built by Neilson to the designs of W. Cowan for the Great North of Scotland Railway. These engines are illustrated in Col-

burn's "Locomotive Engineering." The bogie had a long 6ft. wheel base. The spherical pivot was carried in a cast iron socket on a sliding block bearing on steel slides and guided by two transverse plates. The lateral traverse was 1in. on each side. There were no inclined planes or other form of controlling force. The Adams bogies with spring controlling force have already been mentioned. William Adams's patent was dated February 13th, 1865, but it had been anticipated by R. Stephenson and Co., who in December, 1861, prepared a design, due to their chief draughtsman, J. D. Wardale, for a 4-2-2 tank engine for the Metropolitan Railway, which was, however, not patented. In this design the bogie centre block was arranged with lateral sliding motion controlled by a volute spring on each side, the arrangement being identical in principle with that of Adams. This engine, the drawings for which were submitted to Mr. (later Sir) John Fowler, was not built. Copies of these drawings were published in the *Locomotive*, June, 1924. In 1864 Messrs. Stephenson built eight 4-4-0 tank engines for the Buenos Ayres Great Southern Railway, in which similar spring-controlled sliding bogies were used. The drawings for these engines were dated January, 1864. There is no reason for supposing that Adams had any knowledge of Stephenson's designs.

Tires.—By far the most important development in locomotive construction during this period was the substitution of steel for wrought iron tires, and it is not too much to say that express engines with coupled wheels became a practical success entirely as a result of this change, the credit for which is due to the steel manufacturer, and not to the locomotive engineer.

The old wrought iron tires were originally made of Staffordshire iron, and as loads increased and a better material was required Low Moor or Bowling iron was employed. But all iron tires were defective in that the soft material was squeezed out or crushed when the loads on the wheels exceeded very moderate limits. Wrought iron tires with steeled faces were tried by D. Gooch, Isaac Dodds, and others from 1840 onwards, but their success was sometimes doubtful, and they were stated to have been unreliable owing to brittleness. A steel bar was added to the pile from which the tire was rolled. This was worked to form the tread, but the chilling which occurred during shrinking not only affected the material detrimentally, but so hardened the treads that the latter had to be ground. Gooch seems to have altered his method of steeling the treads, for in D. K. Clark's description of the G.W.R. 4-4-0 tank engines of 1849 it is stated that the steel face was fixed to the iron body by means of dovetails and zinc joints.

Wrought iron tires were at first scarf welded, but double V welds and butt welds were afterwards used, the latter being preferred. The soundness of the weld was tested by means of a

stretching block, but the tire smith on most railways put a mark on the edge of the tire on each side of the weld to locate its position and prevent the wheel shop from securing the tire by a stud or rivet in the region of the weld.

The first to make a weldless tire was the late Mr. (afterwards Sir) F. Bramwell in 1844, when he was manager of a railway carriage works. A coiled wrought iron hoop was wound helically round a barrel and then welded into a solid mass. It was then finished into a true and uniform ring by the continuous rolling process introduced about 1839-40 by J. G. Bodmer. Bodmer's tire rolling mills were at that time made by P. R. Jackson, of Salford, though they were not intended by the inventor for making weldless tires, but to use rolling as a finishing process, leave a hard skin on the tread, and avoid turning the tire in a lathe.

In 1855 Bramwell's method of manufacturing weldless wrought iron tires was taken up by Owens' Patent Wheel and Axle Company, of Rotherham, and also by a firm in France, though the first tires made on this system to a large scale did not come on to the market until about 1861. Owing to the improvements in steam hammers the helical hoop was now hammered down in dies. For tires 5in. wide the unwelded hoop was about 12½in. to 15in. high, and its diameter about one-half that of the finished tire. Whether large driving wheel tires were made on this system the writer has not been able to ascertain definitely, but in 1863 Kitson, of Leeds, was rolling weldless wrought iron locomotive tires, which were fixed to the wheel centres by means of a hooked lip without using studs.

Early attempts at making welded steel tires in this country had naturally been made, but the material then tried was of such a nature that a sound weld could not be relied upon. The first successful steel locomotive tires were manufactured by Krupp, of Essen, in 1851 (according to W. P. Marshall), and before 1860 Krupp's tires had made considerable progress in Germany and France. When steel tires were first used for locomotives in this country the writer has been unable to trace exactly, but it was probably about 1859 when Naylor and Vickers, of Sheffield, supplied some to the L. and N.W.R. The same firm delivered steel tires to the G.N.R. and M.S. and L.R. in 1860, to the N.E.R., N.L.R., and G. and S.W.R. in 1861, and to the Midland and the Great Southern and Western (Ireland) railways in 1863. Robert Sinclair's G.E.R. 2-4-0 engines, built by Messrs. Stephenson in 1861, the Caledonian 8ft. 2in. express engine, and the Crewe-built "Lady of the Lake," all of which were shown at the 1862 Exhibition, had tires of Krupp steel. Krupp's tires were also used for the Metropolitan 4-4-0 tank engines of 1864, and on the Midland 2-4-0 fast passenger engines of 1867. But the smaller railways appear to have been quite as much to the fore in their adoption of steel. On the Taff Vale, under Joseph Tomlinson, the

change from iron to steel began in 1861, and after 1863 no iron tires were used except for tenders. The Maryport and Carlisle Railway also adopted steel about 1862.

There were several methods of making steel tires. Krupp made a square bloom of crucible cast steel, which was drilled through in two places, and the holes opened out into a single aperture. The bloom was then reheated, reduced to a circular shape under the hammer, and finally shaped in the rolls. Naylor and Vickers introduced the process then used at Bochum in Westphalia, and made crucible tires in moulds. The method of casting was then kept secret, but it was commonly understood that the moulds were highly heated and the castings allowed to cool in them very gradually. Six tires were cast together, one above the other, and then separated by a saw; each was then finished to size and contour in the rolls. Both these processes were very expensive.

When the Bessemer process was first used the material was such that welded tires could be made. This method was soon discarded and replaced by one in which a large ingot was hammered into a cylindrical form and cut into discs, which were reheated, punched, and rolled in a Galloway tire machine which finished the tire in one operation at the second heat. About 1864 Messrs. George Brown and Co., of Rotherham, also brought out an improved tire rolling mill, which seems to have ante-dated the rolling in use at Bessemer's works.

The first tire rolled on this machine was made of wrought iron puddled into a ball and punched, and the event is stated to have created some stir. An Irishman accepted a wager to bowl this tire from Rotherham to Doncaster and back, and more than 100 persons accompanied him on the journey. The manner of entry of this tire into Doncaster appears to have been somewhat unorthodox, seeing that the railway had no part in the proceedings.

The later usual method of hammering a steel ingot, cutting off the end, and punching a hole to allow it to be rolled into a finished tire followed immediately, and Messrs. Henry Bessemer and Co. appear to have been the first to adopt this plan. There is, however, much in the history of steel tire making between 1851 and 1865 which is still obscure.

In 1866 the L. and N.W.R. erected a Bessemer plant at Crewe under J. Ramsbottom's supervision. The ingots were cast in the form of solid short cones, which were then hammered in a special duplex hammer invented for the purpose. The resulting short conical disc was by this method consolidated in the centre, through which it was punched and afterwards rolled. To test the material at Crewe some of the bored tires were made red hot and shrunk on to solid cast iron wheel centres. It was stated that no cases of fracture occurred.

There appears to be no information as to the tensile strength of English steel tire material of

the days before 1868, in which year the Steel Committee tested steel bars of hammered tire material, of which Bessemer steel showed a mean "elastic strength" of 23.3 tons per square inch, ultimate strength 35.09 tons per square inch, with an extension of 11.1 per cent. Crucible steel gave a mean "elastic strength" of 20.62 tons per square inch, ultimate breaking strength 35.51 tons per square inch, with an extension of 9.17 per cent.

When the writer was at Swindon a number of tires originally put on in 1868-71, which had run long mileages, were removed, and afterwards tested and analysed. The results are given in Table II. The high tenacity of the Krupp tire may be noted.

The results given by steel tires, as regards wear and mileage, compared with iron tires were very marked. The Great Eastern 2-4-0 engines of 1861 with Krupp tires were stated to have run 60,000 to 70,000 miles without being re-turned. One pair ran 68,000 miles for $\frac{1}{4}$ in. wear on the treads. In the case of Midland engines of the 1867-71 period, William Kirtley, afterwards locomotive superintendent of the L.C. and D.R., stated that with the heaviest engines only 50,000 to 60,000 miles could be obtained with iron tires, crucible cast steel tires gave a mileage of 120,000 to 150,000, the tires having a thickness of $2\frac{3}{8}$ in. when new. The softer Bessemer steel tires ran about two-thirds of the mileage of the crucible steel tires.

Although the locomotive superintendents were glad enough to avail themselves of the harder material and so keep their engines out of the shops, there were some countervailing disadvantages. There was a considerable number of tire fractures; a peculiarity of some of these being that the tires broke into several pieces, which were thrown off to a considerable distance. Many, though not all, of these occurrences took place in frosty weather, and for a long time it was held that frost had a detrimental effect on the material of the tire. The writer considers that the breakages were due to other primary causes. First, the shrinkage allowance at that time was settled by rule of thumb, and there were probably very many cases of tires shrunk on too tightly, and put to work in an overstressed condition. A tire snapping from this cause alone would naturally be expected to break in one place only. But, in addition, there probably was a lack of suitable heat treatment, and work was done on the tires at critical temperatures. If these two primary causes were combined with the secondary effect of frost, not on the tire itself, but in making the road bed hard and unyielding, it is conceivable that a sudden lateral blow, acting upon a brittle and already overstressed tire, might cause it to break in several places. Several such breakages occurred in the case of the tires of leading wheels. An additional likely cause may have been the presence of excess of phosphorus, which would make the tire brittle at low temperatures.

TABLE II.—Steel Tires of 1868-1871.

Maker.	Nature of steel.	Date put on.	Dia. of driving wheels.	Weight on driving wheels (pair)	Total mileage	Tensile test.			Chemical analysis				
						Breaking stress per sq. in. on original area	Elongation in 2' in 2 1/2'	Contraction of area	C.	Si.	Mn.	S.	P.
Vickers	Crucible	Oct., '68	ft. 5 9	t. 11 10	411,349	L 37.65 X 35.36	21.5	32.7	.34	.11	.13	.02	.059
Cammell	Bessemer	Apr., '68	5 9	12 0	314,417	L 36.01 X 35.51	15.1 24.65	23.7 43.4	.34	.033	.46	.08	.037
Cammell	Bessemer	Sept., '69	5 9	12 0	273,087	L 37.88 X 36.53	10.0 20.77	11.1 31.73	.36	.063	.418	.06	.021
H. Bessemer	Bessemer	Nov., '69	6 0	10 10	301,435	L 35.78 X 32.86	15.0 12.86	26.88 28.69	.45	.013	.375	.08	.05
Krupp	Crucible	'71	5 9	16 18	193,447	L 44.7 X	17.6 5.0	11.36 5.6	.52	.271	.468	.037	.066

L, Test piece along the tire.

X, Test piece across the tire.

The first four tires were taken off 2-1-0 tender engines of the G.W.R. The fifth (Krupp) tire was removed from one of the Metropolitan District Railway 4-4-0 tank engines and owing to the sharp curves on that line, and the heavier weight on the wheels, underwent much more severe service.

Steel Axles and Motion Parts.—In the use of steel for axles and motion parts, as in the case of tires, Continental locomotive constructors were ahead of those in this country. It is but fair to add that there was a greater incentive to use steel abroad, where, except perhaps in Sweden, there was no iron of the special and extremely high quality of the Low Moor, Bowling and Farnley brands, which, for locomotive purposes other than tires, had proved in every way satisfactory to British engineers. The purity of Yorkshire iron was chiefly due to the absence of sulphur in the "Better-bed" coal, which lay in the district. There was, therefore, very great reluctance in this country in giving up such reliable material for the more uncertain steel of that day. Moreover, Continental engineers, who were building larger engines for freight and mineral trains, were striving to reduce the detailed weights and turned to steel as the best means of effecting this end.

At the 1851 Exhibition in London Krupp showed steel axles. When steel axles were first used in British practice the writer has been unable to determine. The Caledonian Railway provided "cast steel" straight driving axles for the large 2-2-2 engines, with 8ft. 2in. driving wheels, about 1860. They were made at St. Rollox, but subsequently a number broke in service, though this may possibly have been due to insufficient diameter. On the Taff Vale Railway from 1863 onwards, Joseph Tomlinson used either "cast" or Bessemer steel for all axles except crank axles. Messrs. Vickers made forged steel crank axles in 1865, and in 1866 supplied them to the S.E., L.C. and D., and L. and Y. railways. The London and North-Western Railway adopted Bessemer steel crank axles about 1866, and some of Sturrock's Great Northern engines of the same period had Krupp steel axles. But for many years there was considerable distrust of steel crank axles, except perhaps on the L. and N.W.R., and it was nearly twenty years before they were generally considered to have "made good." It is probable that much of the distrust was due to the lack of "work" put into the early axles. The hammers, though large enough for forging wrought iron axles, were not always sufficiently powerful to affect the "core" of the steel axle, and only the surface metal received suitable "work," so that perfect homogeneity of structure was lacking. The heat treatment was probably in many cases defective.

Referring to heat treatment, it may be of interest to refer to a locomotive by Borsig, in the London 1862 Exhibition. This engine had connecting, piston and coupling rods, crank pins and axles of Krupp steel. A letter by Borsig, published subsequently in Paris, stated that all these parts were, when forged, tempered by being heated in an air furnace to a red heat. After the "tempering," they were reheated to a cherry red, and cooled. Any bad material showed cracks, and was rejected. In mentioning this letter, the writer does not imply that the British steel makers

of that day did not subject their steel to proper heat treatment, but whether all the railway and locomotive works fully understood the new material with which they were dealing is an open question, and they may not have been so thoroughly coached by the steel manufacturers as were the German locomotive builders.

The following direct tensile tests were made by Wöhler upon the axle steels, which he also tested under alternating stresses, and are of interest in that both German and English steels were then used for locomotive axles in this country.

Bars from steel axle by	Ultimate tensile strength, tons per sq. in.	Elongation, per cent.
Krupp, 1853	41.8	23.7 and 17.4
Krupp, 1862	48.98	12.1
Krupp, 1862	50.15	18.6 and 11.7
Bochum, 1863, average	42.27	18.65
Borsig, 1863	39.41	21.7
Borsig, 1863	37.26	22.3
Vickers, 1868	29.14	19.5
Vickers, 1868	26.27	15.8

The German figures have been reduced to British tons per square inch. The length of the specimens from which the elongations were derived were not given.

A test of Messrs. Naylor, Vickers and Co.'s axle steel made by Sir W. Fairbairn showed a tensile strength of 39.58 tons per square inch. Tests by the "Steel Committee" in 1868 gave the following results:—Hammered Bessemer steel axles: "Elastic strength," 21.87 tons per square inch; ultimate breaking strength, 33.47 tons per square inch; permanent extension, 12.1 per cent. Hammered crucible steel axles: "Elastic strength," 25.56 tons per square inch; ultimate breaking strength, 40.93 tons per square inch; permanent extension, 8.72 per cent. The specimens tested were 1.382in. diameter by 4ft. 2in. long, and therefore the percentage elongation figures are smaller than would have been obtained with shorter test specimens. The loose expression "elastic strength" is that used in D. K. Clark's synopsis of the original report ("Rules, Tables and Data for Mechanical Engineers," 1878 edition).

In 1862 Robert Sinclair on the G.E.R. used Krupp steel for piston rods, valve spindles, straight axles and crank pins, as well as for guide bars. He also used cast steel horncheeks and cast iron axle-boxes with chilled faces.

Axle-boxes and Journals.—To avoid the working loose of brasses when fitted into axle-boxes, the former were frequently cast in. Axle-box keeps were sometimes made to contain sponges or closely packed cotton waste, and in some cases the sponges were held up to the journals by springs. The writer cannot state definitely who introduced these improvements, but some of them were used by Sinclair.

Boilers.—In 1860 the Midland Railway, under Matthew Kirtley's superintendency, re-introduced welded longitudinal seams to replace the old lap-

jointed seams. This practice coincided with an increase of pressure to 140 lb. The boilers were made of $\frac{7}{16}$ in. Yorkshire iron plates in three barrel rings. The plates were rolled with thickened edges, tapering up to $\frac{3}{8}$ in., the length of taper being 4 in., and similar thickened edges were used for the circumferential joints. The longitudinal seams were welded, all three rings being of the same diameter. The circumferential joints were strengthened by outside double-riveted butt strips, and in addition hoops were shrunk over the middle of each ring, crossing the welded joints and being secured by a few rivets. Hoops and covering strips were blocked before being shrunk on, and all rivet holes were drilled with the hoops in place. The rings were made in two semi-circular portions, so that two longitudinal welds were necessary for each ring. The weight of a welded boiler with the higher pressure 11 ft. long by 3 ft. 11 in. inside diameter was $7\frac{3}{4}$ tons, as compared with $6\frac{1}{2}$ tons for the old construction, and the cost was about 12½ per cent. greater. Tests of strips showed that the original plates had a tenacity of 23.6 tons and the welded portions 20.6 tons per square inch. After trials with nineteen boilers lasting over six years the welded boiler was adopted in 1866 as standard, owing to the lessening of repairs necessitated by grooving, but welding was discontinued a few years later, except in the case of the middle ring, on which the dome was placed.

Owing to their great length, Cudworth's fire-boxes from 1860 were provided with transverse in place of longitudinal roof girder stays. Generally, alternative girders were slung on each side from tee irons attached to the casing. This was probably the earliest application of transverse girders, but whether sling stays were then new the writer is unable to state. Cudworth also used tilting grates at the tube plate end.

The earliest steel boilers were made in 1862 and 1863 for the Maryport and Carlisle and the L. and N.W. railways, in the latter case at Crewe. The Crewe boilers seem to have been experimental, since Low Moor iron was still being used for some years afterwards. The L. and N.W.R. engines carried only 120 lb. pressure until about 1872. Steel boilers were looked upon with even greater suspicion than steel crank axles. The plates pitted much more rapidly than those of wrought iron, and generally their behaviour was far from satisfactory. A. Allan tried steel fire-boxes on the Scottish Central Railway during 1860-63. From about 1862 the boilers for the Maryport and Carlisle Railway had steel fire-boxes and tubes made by D. Adamson and Co., of Hyde, for engines built by Mr. Tosh, locomotive superintendent at Maryport. They appear to have lasted for several years.

The rigid fastening of the motion plate to the barrel was dispensed with, but it was still thought advisable to carry the plate up to the boiler to give the latter support in the saddle formed by the double angle irons. A rubbing plate was some-

times riveted to the boiler, to protect it when sliding in the saddle.

Fittings.—The most important detail with the exception of steel tires was the injector invented by Giffard in France in 1859. The patent rights were taken up in this country by Sharp, Stewart and Co. in 1860, and some notes regarding the invention were given in *The Engineer* of August 31st, 1923, page 231. It was adopted at once by most railways, though many locomotives were for a time also provided with feed pumps in case of emergency. As soon as the new appliance had proved itself, the pumps, except in the case of Beattie's South-Western engines, were soon discarded. Engineers were not sorry to get rid of them, especially the crosshead-driven type. Apart from their inability to feed the boiler when the engine was standing, the hydraulic ram action when working at high speeds caused many bursts of both pumps and pipe connections. W. Stroudley at a later date re-introduced crosshead pumps on the Brighton engines to deal with hot feed water, and Professor Goodman, experimenting with them, found that the pressure sometimes amounted to 3500 lb. per square inch. It was reduced to 900 lb. per square inch by enlarging the capacity of air vessels and pipes to five times the capacity of the pumps, but further enlargement failed to reduce it materially below this point.⁸

Clack boxes were generally fixed to the front or middle ring of the boiler, but P. Stirling, on the Glasgow and South-Western Railway, about 1861, when fitting his engines with injectors, delivered the feed into the water spaces at the sides of the fire-box immediately above the foundation ring. Judging from the fact that the clack boxes re-appeared on the boiler barrel shortly afterwards, the fire-box side delivery appears to have left something to be desired, though in the first G.N.R. 8 ft. singles the clack boxes were also fixed on the sides of the fire-box casings.

Roscoe's well-known displacement lubricators came out in 1862. The inventor was district superintendent at Leicester (M.R.). Within a few years all Midland engines, as well as many on other railways, were fitted with them, and for about twenty-five years they were almost universal. The principle was similar to that of Ramsbottom's lubricator, but the steam entered the side of the oil vessel near the top instead of through a vertical tube through the bottom.

Screw Reversing Gear.—The credit for this invention is due to John Ramsbottom, who first applied it to the "Lady of the Lake" 2-2-2 engines at the end of 1859. The design is shown in Colburn, Plate II. Sinclair adopted it about 1862, but the design, which had a catch on the hand wheel, was different. This arrangement was designed by the late Dr. W. H. Maw, and was extensively copied on the Continent, both in Germany and France.

⁸ Goodman, "Mechanics Applied to Engineering."

Chapter XIII—1866-69

EXPRESS ENGINES WITH "SINGLE" DRIVING WHEELS.—Before the year 1866 had come to an end, most of the leading railways had discontinued the construction of "single" engines, at least for a considerable period. This does not

illustrated by Fig. 210. They had 17in. by 24in. cylinders, driving wheels 7ft., and carrying wheels 4ft. diameter, wheel base 7ft. 8in. + 8ft. 4in. = 16ft. An excellent feature of Great Western practice was the ample boiler power pro-

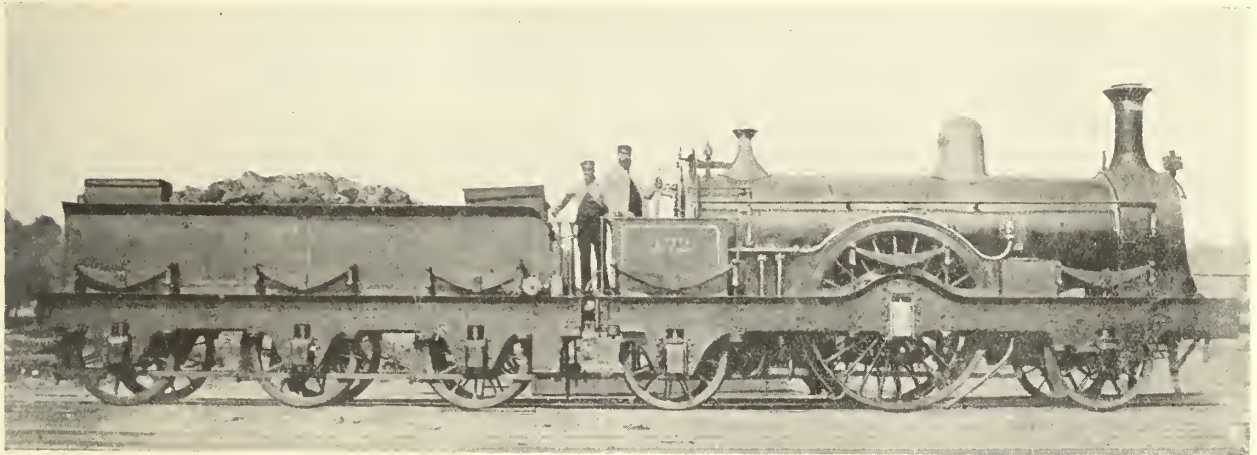

[Photo. Locomotive

FIG. 210—ARMSTRONG'S EXPRESS LOCOMOTIVE, GREAT WESTERN RAILWAY, 1866-69

imply by any means that those already built were relegated to secondary services, since for many years to come the majority of express trains were worked by them. There were two railways, the Great Northern and the Great Western, the locomotive superintendents of which differed from

vided. The barrel was 11ft. long by 4ft. 2in. diameter, and the total heating surface 1268.9 square feet, of which the fire-box supplied 98 square feet; grate area, $16\frac{3}{4}$ square feet. The original weight was 29 tons 4 cwt., of which 12 tons 8 cwt. rested on the drivers. Subsequently



FIG. 211—CONVERTED GOODS ENGINE, G.W.R.LY., 1900-02

their colleagues on other lines, and held stoutly to the single engine.

Joseph Armstrong's G.W.R. standard gauge express engines, built at Swindon 1866-69, are

this weight proved insufficient, and modifications were made which increased the total weight to $31\frac{1}{2}$ tons, of which 14 tons were available for adhesion. An unusual metamorphosis of these

engines took place when 21 of the total of 30 were converted by W. Dean in 1900-1902 to 0-6-0 goods engines, as shown by Fig. 211, the old frames and motion being retained.

In 1866 A. Sturrock on the G.N.R. fell into line with other locomotive engineers, and designed six

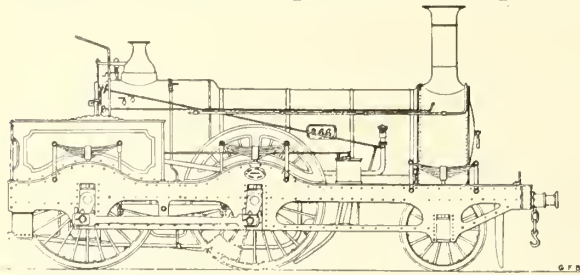

FIG. 212—A. STURROCK'S EXPRESS ENGINE, G.N.R., 1866

large 2-4-0 express engines, which were built by John Fowler and Co., of Leeds, and the Yorkshire Engine Company, of Sheffield. They had double frames, the outside members being of the sandwich type. The engines are illustrated in Fig. 212. The cylinders were 17in. by 24in., driving coupled wheels 7ft. diameter. The leading wheels were placed underneath the smoke-box, with the

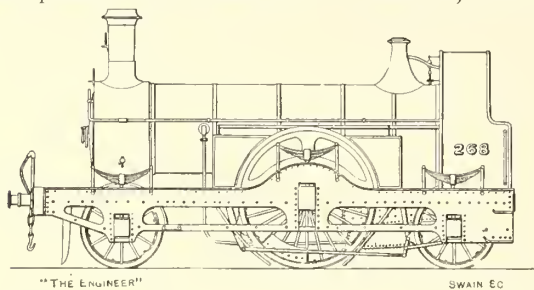

FIG. 213—A. STURROCK'S G.N.R. ENGINE AS REBUILT 1873-5

result that the remarkably long wheel base of 9ft. 7in. + 8ft. 6in. = 18ft. 1in. was obtained. The axles and tires were of steel, and the outside coupling rod cranks had the long throw of 14in. In this respect Sturrock seems to have followed E. B. Wilson's practice. The engines were not

subsequently; suffice it to say here that the coupled express engine was far from showing superiority over the "single" at that time.

As soon as P. Stirling took charge in 1866 of the locomotive department of the G.N.R., he determined to adhere to single engines, just as he had done on the Glasgow and South-Western Railway. His first express engines, of which 13 were built at Doncaster, 1868 to 1870—Fig. 214—differed completely from his outside cylinder inside framed designs for the Scottish railway. The G.N.R. engines were of an enlarged and much improved "Jenny Lind" type, with inside cylinders, inside bearings for the driving wheels only, and outside bearings for the carrying wheels. Stirling at once adopted Sturrock's long wheel base with leading axle under the centre line of the smoke-box. The domeless boiler with perforated steam pipe, and the plain but efficient G. and S.W. cab with circular side windows also appeared. The cylinders were originally 17in. by 24in.; but some years later were enlarged to 17½in. diameter. The driving wheels of 12 engines were 7ft. 1in. diameter, but the thirteenth—No. 92—had 7ft. 7in. drivers, the wheel centres having been taken from Sturrock's large bogie engine, which was broken up in 1870. The wheel base of the first twelve was 9ft. 6in. + 7ft. 6in. = 17ft., increased in the case of No. 92 to 9ft. 9in. + 7ft. 9in. = 17ft. 6in. The boiler, the centre of which was pitched 7ft. 2in. above rail level—7ft. 4in. in the case of No. 92—had a total heating surface of only 1011¾ square feet, of which the fire-box provided 89½ square feet; grate area, 16.4 square feet; pressure, originally 130 lb.; weight on drivers, 14 tons; total weight in working order, 33 tons. The hornblocks were of cast steel.

The heating surface of Stirling's engines was always comparatively small, but he rightly preferred plenty of space between the tubes, which in the above engines were 192 in number and 1¾in. diameter. In one of them the tubes were reduced to 1⅞in. diameter without affecting the efficiency of the boiler from the running point of view. The fire-box roofs were stayed by girders.

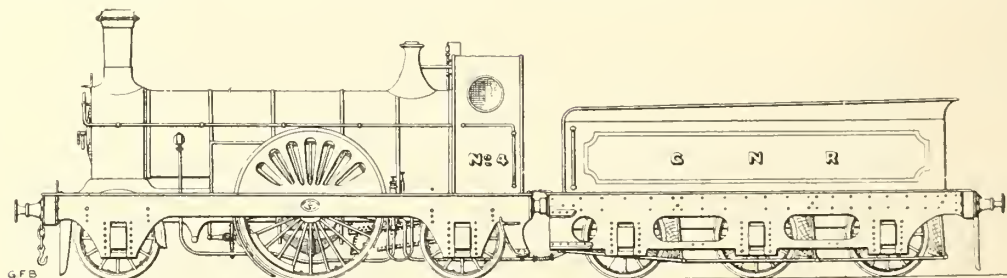

FIG. 214—P. STIRLING'S EXPRESS ENGINE, GREAT NORTHERN RAILWAY, 1868

very successful on the fastest express trains, and between 1873 and 1878 Stirling rebuilt all of them as 2-2-2 single engines—as shown in Fig. 213. The reasons for this alteration will be mentioned

Four-coupled Express and Passenger Engines.—P. Stirling also designed the 2-4-0 engine illustrated by Fig. 215. Twenty of the type were built by the Avonside Engine Company

and the Yorkshire Engine Company in 1867-68, and therefore preceded the single engines described above. As built, the cylinders were 17in. by 24in., enlarged subsequently to 17½in. diameter. Diameter of driving wheels, 6ft. 7in.; and of leading wheels, 4ft. 1in.; wheel base, 9ft. 6in. + 8ft. 3in. = 17ft. 9in.; total heating surface, 1085½ square feet. The leading plate springs were placed below the platform behind the

trains, and to the end of Stirling's life the single engine remained supreme for Great Northern express work. It is a noteworthy fact that though Stirling's "singles" of all classes did wonderful work, the coupled engines, though very good for semi-fast and stopping trains, were much inferior on the expresses. The reason probably lay in the fact that the celebrated old engineer went somewhat too far in reducing his boiler power.

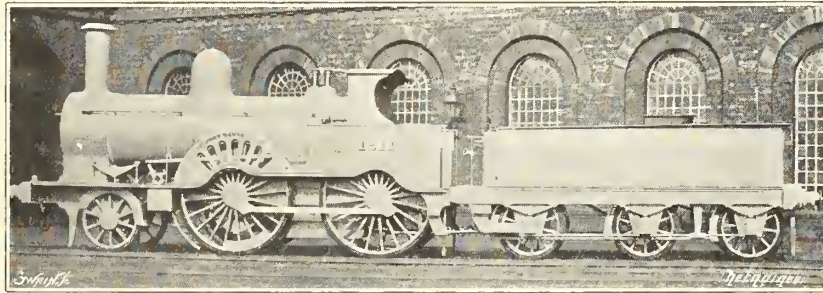

FIG. 215A—J. RAMSBOTTOM'S ENGINE FOR THE L. & N.W. RLY., 1866-73

framing, an inaccessible position in case of breakage. Nevertheless this practice was continued throughout Stirling's superintendency, and it was not until Mr. Ivatt's time that all Stirling's engines were altered and the springs removed to the usual position above the platform. Fig. 215 does not depict one of these engines as originally built, but is sufficiently indicative of the class.

From 1874 onwards the cylinders of the later engines were 17½in. by 26in., but in most respects the type remained the same until 1895, the principal changes being that the pressure was increased

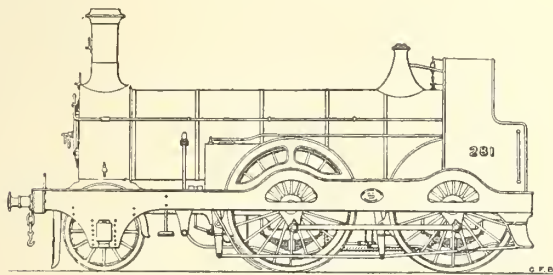

FIG. 215—P. STIRLING'S PASSENGER ENGINE FOR THE GREAT NORTHERN RAILWAY, 1867-68

about 1888 to 160 lb., and the wheel base between leading and driving wheels lengthened to 9ft. 8in. On the other hand, as time went on the tube heating surface, as in the case of nearly all Stirling's engines, was reduced, though that of the fire-boxes remained practically the same. The total heating surface of the later engines was only 929.3 square feet in spite of the larger cylinders.

The first twenty engines of 1867-68 were probably intended for express trains, but if so, they were soon relegated to service with secondary

The 2-4-0 express engines of the L. and N.W.R.—Fig. 215A—were built at Crewe 1866-73, to J. Ramsbottom's designs, and were primarily intended for the express services between Crewe and Carlisle, and Crewe and Holyhead. They must not be confused with F. W. Webb's later "Precedent" class, which, though of similar general dimensions and mainly derivatives of them, differed in several material respects. There were 96 of the "Ramsbottoms," of which the illustration shows one of the last twenty, which were provided with cabs, instead of the small weatherboards of the earlier engines. All were fitted with Stephenson's link motion. The frames and all bearings were inside in accordance with the invariable practice of the L. and N.W.R. The cylinders were 17in. by 24in. (though in a few of the earlier engines they were stated to have been 16in. diameter originally); driving wheels, 6ft. 7½in.; leading wheels, 3ft. 7½in.; wheel base, 7ft. 5in. + 8ft. 3in. = 15ft. 8in. The boiler, the centre of which was 6ft. 11in. from rails, contained 192 1¼in. tubes, of which the heating surface was 1013 square feet; total heating surface, 1102 square feet; grate, 14.95 square feet. Weight in working order of the earlier engines:—Leading, 9 tons 8 cwt.; driving, 10 tons 10 cwt.; trailing, 8 tons 15 cwt.; total, 28 tons 13 cwt. The pressure was 120 lb., a figure somewhat low for the period when the engines were built.

The earlier engines of 1866-71 were provided with Ramsbottom's usual air inlets, consisting of two circular holes, 7in. diameter, in the front of the fire-box under the brick arch, and covered by doors worked from the footplate to regulate the air entry. These holes were abandoned by F. W. Webb, as they caused trouble with the fire-box

plates. Although steel boilers had been tried previously, these engines had boilers of Low Moor iron $1\frac{3}{32}$ in. thick.

For the Derby-Manchester section and also in anticipation of the opening in 1868 of the main

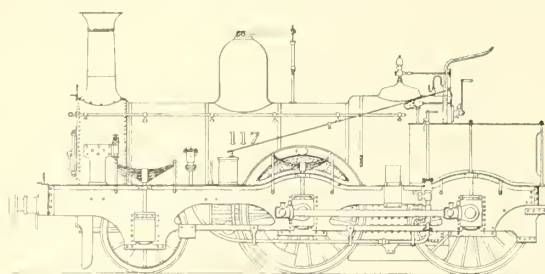

FIG. 216—M. KIRTLLEY'S MIDLAND ENGINE, 1866-68

line extension from Bedford to St. Pancras, for the traffic on which the existing single engines were not suitable in view of the gradients, the Midland Railway placed in service a type of 2-4-0 fast passenger engine, of which there were two distinct designs, though the general dimensions were similar. Both classes had $16\frac{1}{2}$ in. by 22 in. cylinders, 4 ft. 2 in. leading and 6 ft. 2½ in. coupled wheels, with a wheel base of 8 ft. + 8 ft. 6 in. = 16 ft. 6 in. Like all Midland passenger engines built before 1870, the boilers, which carried 140 lb. pressure, had raised fire-box casings. But the details of the motion and outside framing were entirely different, and as they represent typical designs, both are illustrated. The engines—Fig. 216—were designed and built at Derby in 1866-68. The outside plate frames were of the slotted out type, the ties between the horns being solid with the plates. The cylinders were horizontal, and the

account of the strength and solid design of the original frames. They were rebuilt by S. W. Johnson in 1895-99, with 18 in. by 24 in. cylinders, and nearly twenty of them are still at work, under London, Midland and Scottish Rly. Nos. 1 to 22.

Of the other class—Fig. 217—thirty were built by Beyer, Peacock and Co. in 1867, and were typical of this firm's double plate framed engine. The frames were not so deep as those of the Derby-built engines, and were without the tie connections between the horns. The platforms were lower. The tires were of Krupp steel. The valve spindles were suspended by swing links from brackets attached to the motion plate. These engines also did good service for a period of thirty to thirty-five years, but the writer understands that the design was not so adaptable for the larger 18 in. by 24 in. cylinders, which were later required, and they were broken up.

The original boilers of the above engines were 11 ft. long by 3 ft. 11 in. diameter inside the front ring, and contained 168 2 in. tubes. The total heating surface was $1071\frac{1}{2}$ square feet, of which the fire-box supplied 80.1 square feet; grate area, 14.8 square feet; the average weight was $33\frac{1}{4}$ tons.

As now running, the Derby-built engines—L.M.S., Nos. 1 to 22—with 18 in. by 24 in. cylinders, have a total heating surface of $1079\frac{1}{2}$ square feet, with larger fire-box, and weigh $41\frac{1}{4}$ tons in working order.

The excellent little passenger engines—Fig. 218—were amongst the earliest of S. W. Johnson's design. They were built for the G.E.R., 1867-72, during his locomotive superintendence of that railway, thirty by Sharp, Stewart and Co., and ten at Stratford works, and were derived from a class for which he was responsible when on the North British Railway. The latter had larger 6 ft.

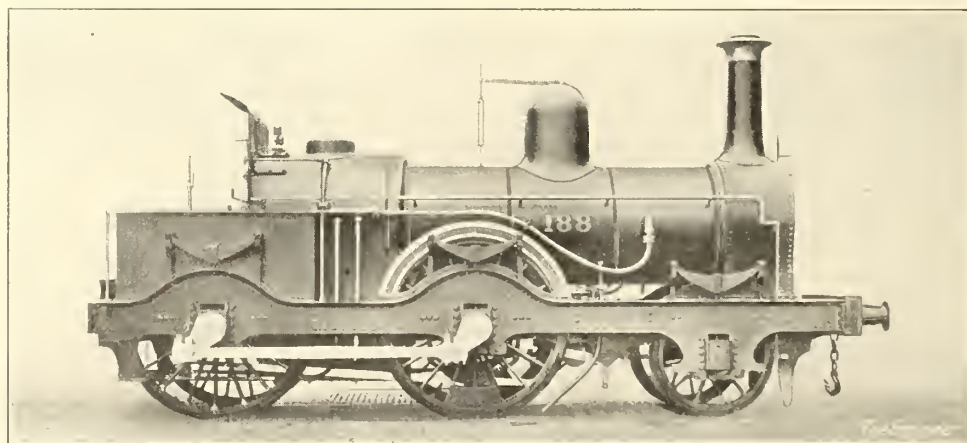

FIG. 217—M. KIRTLLEY'S MIDLAND ENGINE, BUILT BY BEYER, PEACOCK & CO., 1867

valve spindles were supported by the usual Midland type of guides bolted by means of flanges to the upper slide bars, of which there were four. These engines, which have done excellent service, seem to bear a charmed life, chiefly on

wheels and domeless boilers. The cylinders of the G.E.R. engines were 16 in. by 22 in.; diameter of coupled wheels, 5 ft. 7 in.; wheel base, 14 ft.; total heating surface, $772\frac{3}{4}$ square feet; weight of engine in working order, 29 tons $2\frac{3}{4}$ cwt.; pressure,

140 lb. For a period of thirty-five to forty-seven years they worked principally over the long cross-country lines of the Great Eastern.

Of 2-4-0 express engines with outside cylinders, the majority were to be found on the London and

total, 920 square feet; pressure, 140 lb.; grate area, 14.4 square feet. The total weight in working order of the earlier engines was 33 tons. This type of engine was built until 1874, the last series by Dübs and Co. having 17½ in. cylinders.



FIG. 218—S. W. JOHNSON'S ENGINE FOR THE GREAT EASTERN RAILWAY, 1867

South-Western and Caledonian Railways. Joseph Beattie's engines on the former line were generally similar to those already described—Fig. 141 *ante*. All had 17 in. by 22 in. cylinders and 130 lb. pressure, and, with the exception of thirteen with 7 ft. wheels, had 6 ft. 6 in. coupled wheels.

For the express and fast trains on the northern sections of the Caledonian Railway, and also between Greenock, Glasgow and Edinburgh, this type of coupled engine—Fig. 219—was designed by B. Connor. As on the L. and S.W.R., there were two classes, with 7 ft. 2 in. and 6 ft. 8 in. coupled wheels, of which the former, built in 1867-68 by Neilson and Co. and at St. Rollox works, had the largest coupled wheels in the country. The old Crewe type of mixed framing was retained. The cylinders of both classes were 17 in. by 24 in., and the wheel base 7 ft. 1½ in. + 8 ft. 7 in. = 15 ft. 8½ in. The boilers were small,

A feature of Caledonian practice was the use of double coned journals.

Four-coupled Mixed Traffic Engines.—Although presenting no special features beyond extreme simplicity, P. Stirling's 0-4-2 engines, the "maids of all work" on the G.N.R., must not be omitted. This type—Fig. 220—was the first designed and built by Stirling for the G.N.R. at Doncaster in 1867, from which year until 1895, no less than 154 were placed in service, with only slight variations in detail between the first and the last. They worked most of the passenger traffic in the West Riding, and the greater part of the main and branch line "locals," in addition to all the important main line fast goods trains. The cylinders of the earlier engines were 17 in. by 24 in., enlarged subsequently to 17½ in. by 24 in., which remained the standard size for all of the class. Coupled wheels, 5 ft. 7½ in. diameter;

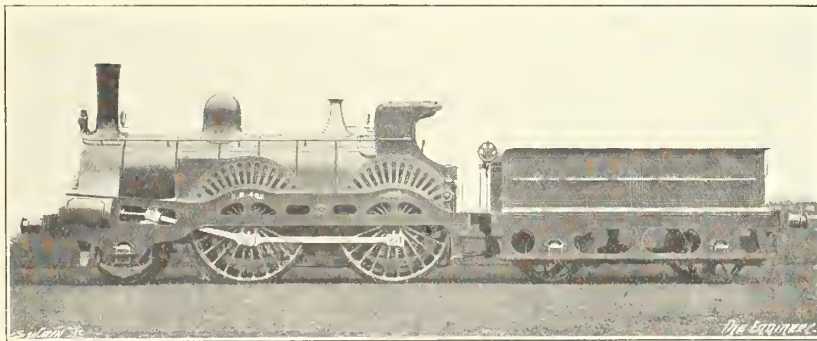

FIG. 219—B. CONNOR'S CALEDONIAN RAILWAY ENGINE, BY NEILSON & CO., 1868

as regards total heating surface, which varied in different classes. In the engines—Fig. 219—by Neilson and Co., 1868, there were 150 2 in. tubes in a barrel 4 ft. 2 in. diameter outside; tube heating surface, 834 square feet; fire-box, 86 square feet;

trailing wheels, 3 ft. 7½ in. diameter; but in the last thirty-three engines, from 1882 onwards, the diameter of the latter was increased to 4 ft. 1½ in. There was some variation in the boilers, but the heating surface was always small, ranging from

1075 square feet in the earlier to $837\frac{1}{2}$ square feet in later engines. The heating surface given by P. Stirling to his boilers had a way of becoming "small by degrees and beautifully less" as the years passed by, not only in the case of these, but also of his express engines. The pressure was 140 lb. The wheel base was 7ft. 3in. + 7ft. 11in.

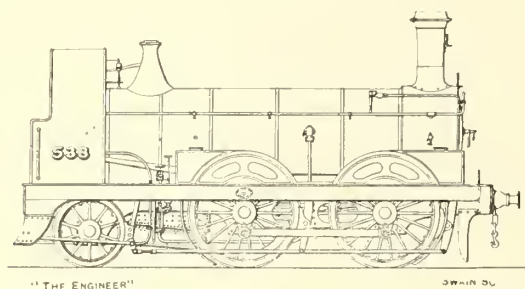

FIG. 220—P. STIRLING'S GREAT NORTHERN ENGINE, 1867-79

= 15ft. 2in. until 1882, when the distance between driving and trailing centres was increased to 8ft. The average weight in working order was about $32\frac{1}{4}$ tons, of which nearly 26 tons were available for adhesion.

If one might be allowed to criticise engines which had a long career of usefulness, it would be from the standpoint of insufficient grate area. When working even moderately hard, they threw out a large amount of cinders and unburnt fuel, the result of forcing the small boiler and grate with a small blast pipe. All these engines have now disappeared. H. A. Ivatt rebuilt about ten of them with larger domed boilers in 1902, but discontinued the experiment shortly afterwards. A number of similar engines were designed by

Brassey and Co., of the Canada Works, Birkenhead, for the S.E.R. to J. I. Cudworth's designs. They were derived from some similar 0-4-2 tank engines of 1863-64, and to increase the coal and water space was substituted for the single trailing axle. The axle-box pillars of the coupled wheels were connected by long compensating beams with single spring between, a revival of Cudworth's 1853-55 practice—Fig. 110 *ante*. The bogie, which had a 6ft. wheel base, was of the outside framed pattern, with similar compensating beams, and brake blocks actuated by hand were applied to its wheels. The cylinders were 15in. by 20in.; coupled wheels, 5ft. 7in. diameter; bogie wheels, 3ft. 8in. diameter; wheel base, 7ft. 3in. + 7ft. 3in. + 6ft. = 20ft. 6in.; total heating surface 903 square feet; and pressure, 130 lb. The weight of the locomotive in working order was 33 tons 14 cwt., of which the bogie carried 11 tons $12\frac{1}{2}$ cwt.

A very similar engine was built by J. C. Craven at Brighton works later in 1866. It had 5ft. coupled wheels, 16in. by 20in. cylinders, and the coupled wheels had independent springs.

The celebrated outside cylinder 4-4-0 side-tank engines designed for the North London Railway by W. Adams and built at Bow Works, are illustrated in Fig. 222. The first of these engines came out in July, 1868, since when they have remained the standard type on that railway, with minor modifications which left the principal features of the design untouched. In many respects they were a bold departure. The bogie was of the Adams sliding type, first used in 1865 and having a lateral movement of 2in. each side. But the drawings of these and other early Adams bogies on the Great North of Scotland Railway show no

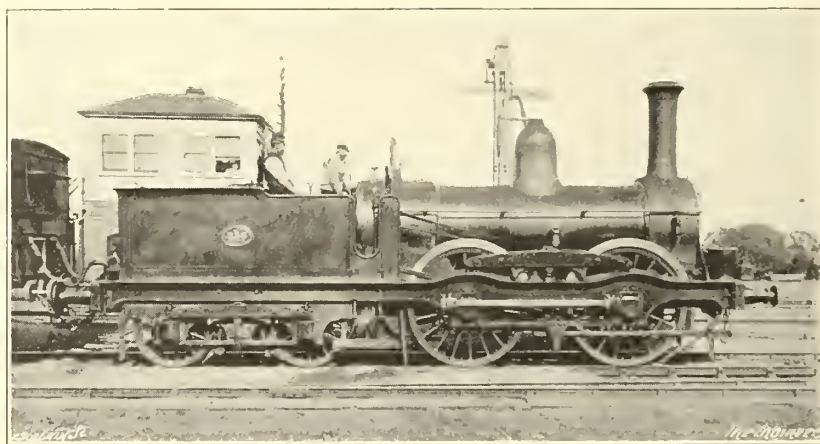

(Photo. Locomotive)

FIG. 221—J. I. CUDWORTH'S SOUTH-EASTERN RAILWAY TANK ENGINE, 1866

James Stirling and built by Neilson and Dübs for the Glasgow and South-Western Railway.

Four-coupled Passenger Tank Engines.—The first 0-4-4 tank engines with front coupled wheels and trailing bogies—Fig. 221—were built by

check springs, which were evidently a later addition. In fact, it was stated that the lower part of the sliding block was made a moderately tight fit between the angle iron slides, so that lateral movement should not take place too readily,

or, in other words, the deviating force was opposed by frictional resistance. But very shortly afterwards india-rubber check springs were added. Between the upper portion of the pivot block, which was widened into a ring, and the

on the bogie was 15 tons 14 cwt., about 1 ton more than when the engine was loaded, owing to the weight of the water and coal being chiefly behind the driving wheels.

Six Wheels Coupled Tender Engines.—The

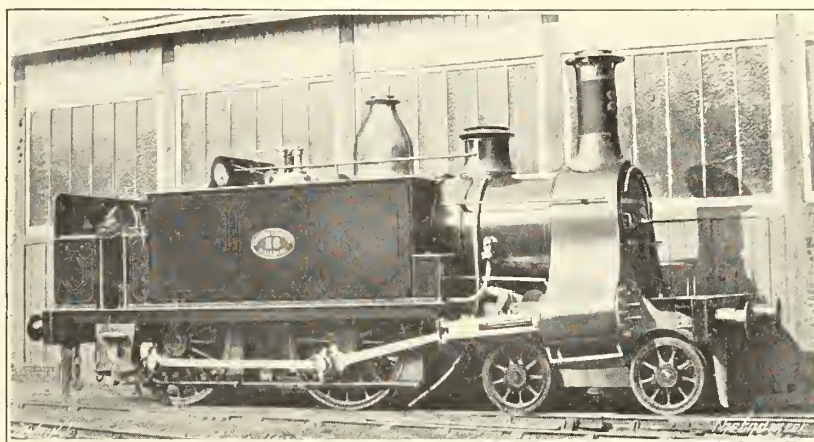

[Photo. Locomotive

FIG. 222—W. ADAMS'S NORTH LONDON RAILWAY TANK ENGINE, 1868

plate sliding on the bearing a thick rubber ring was interposed. Although nearly all locomotive engineers, including Adams himself in later designs, dispensed with the india-rubber ring, and also used spiral or plate check springs for controlling the lateral movement, the rubber ring and check springs are still in use on the North London and Great Eastern bogies.

The cylinders were secured by passing the steam chests through the frames, and to keep them from working loose each steam chest was made with longitudinal planed projections which fitted into grooves in the transverse castings uniting the frames. The horn cheeks of the driving and coupled axle-boxes were of steel, and the horn blocks were of the horseshoe pattern now almost universal. The boiler pressure was 160 lb., the highest at that time in this country. The leading dimensions were:—Cylinders, 17in. by 24in.; coupled wheels, 5ft. 4in.; bogie wheels, 2ft. 9in.

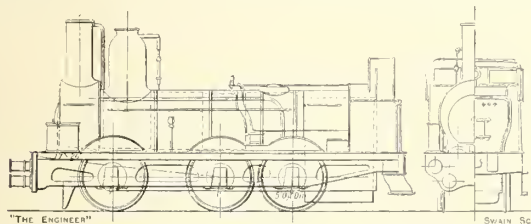

FIG. 223—W. BOUCH'S STOCKTON AND DARLINGTON RAILWAY ENGINE, 1866

diameter; wheel base of bogie, 5ft. 8in.; coupled wheel base, 8ft.; heating surface, 1015 square feet; weight in working order, 43 tons 12 cwt., of which the bogie carried 14 tons 14½ cwt. Of the total weight, 38 tons 12 cwt. empty, the amount

only 0-6-0 engines which need be mentioned were of W. Bouch's Stockton and Darlington "long boiler" type, which from 1866 to 1874 was with slight variations standard on that line. They were built at the company's North Road Engine Works at Darlington and by Hawthorn and Co., Stephenson and Co., Hopkins Gilkes and Co., of Middlesbrough, and other makers. The diagram Fig. 223 shows these engines. Bouch always preferred the "long boiler" engine, for the reason that a larger water area was available. The shape of the inside plate frames is clearly shown in the diagram. A very unusual feature was the fire-box, which had a flat top stayed by direct iron stays to a flat outside casing plate in a very similar manner to the Belpaire fire-box, but differed from the latter in that the top of the outside wrapper plate was lower than the top of the boiler barrel. By the use of direct stays the weight on the trailing wheels was reduced by about ¾ ton. The fire-box had a longitudinal midfeather below the level of the fire-door. The feed-water heater was of Bouch's design, in which the cold feed was led into an annular space round the chimney, where it was heated by exhaust steam which passed through a coil. The exhaust was taken to the chimney by means of a pipe led from the exhaust space just below the base of the blast pipe.

The cylinders of all Bouch's S. and D. engines were 17in. diameter, but the stroke varied from 24in. upwards. The majority had 26in. stroke, but five engines built by Hawthorn in 1870 had 28in. stroke. The wheels had a diameter of 5ft. and, unlike those of many long boiler engines, the driving tires had flanges. Wheel base, 7ft. 9in. + 5ft. 3in. The boiler barrels varied from 14ft. to 14ft. 6in. in length by 4ft. diameter, and the

heating surface attained 1300 square feet in the largest of the type. The weight of the latter in working order was $37\frac{1}{2}$ tons.

Six Wheels Coupled Tank Engines.—These were chiefly used for special service on lines with severe gradients, and there were very few engines specially designed for shunting work. The Great

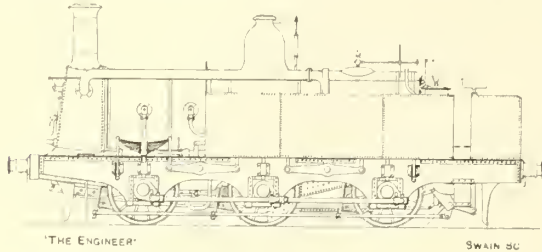

FIG. 224—R. H. BURNETT'S METROPOLITAN RAILWAY TANK ENGINE, 1868

Western in 1864 led the way with 0-6-0 saddle-tank engines for local goods traffic, and a few similar engines were built at Doncaster for the G.N.R. by P. Stirling.

Of the three types which merit special mention, the first—Fig. 224—was specially designed by R. H. Burnett for the passenger traffic on the St. John's Wood section of the Metropolitan Railway, and was built by the Worcester Engine Company in 1868. The gradients, varying from 1 in 27 to 1 in 80, are very severe, and the line rises 235ft. in $2\frac{3}{4}$ miles. The principal consideration which affected the design was that the normal steam pressure of 130 lb. was liable to fall rapidly owing to the necessity for continuous condensing in the tunnel, with the consequent absence of

link motion. The springs of all three axles were connected by compensating levers, which were placed outside the outer frames, for the reason that they were intended to be removed if found unnecessary in service. They were dispensed with subsequently, but whether that was done before the engines were sold is uncertain. The driving and trailing springs were placed in recesses behind the tanks. The wheels were 4ft. in diameter; the wheel base was 14ft. and the leading and trailing axles had lateral play; heating surface, 1132 square feet; grate area, $22\frac{1}{4}$ square feet; weight (full), 45 tons. These engines were too large for the work and less economical than the standard 4-4-0 tank engines, and when Joseph Tomlinson became locomotive superintendent they were laid aside, and afterwards sold to the Taff Vale and Sirhowy Railways, on which the cylinders were lined up to $17\frac{1}{2}$ in. and 18in. diameter. Sectional drawings were published in *The Engineer*, October 4th, 1895.

For the Brecon and Merthyr Rly. main line, which has very long banks of 1 in 38 to 1 in 40, the engines illustrated in Fig. 225 were designed and built by Sharp, Stewart and Co., 1865-68. These were considered extremely powerful engines at that time, and their duty was to take ten loaded wagons and two vans—100 tons—at the regulation speed of 8 miles per hour up the Talybont bank of 1 in 38 for about $6\frac{3}{4}$ miles. They were saddle-tank engines of the Stephenson long boiler type, the wheel base being 12ft. The cylinders were 17in. by 24in.; coupled wheels, 4ft. 6in.; the boiler barrel was 4ft. $1\frac{3}{4}$ in. diameter outside and contained 148 2in. tubes, 13ft. 9in. long; tank

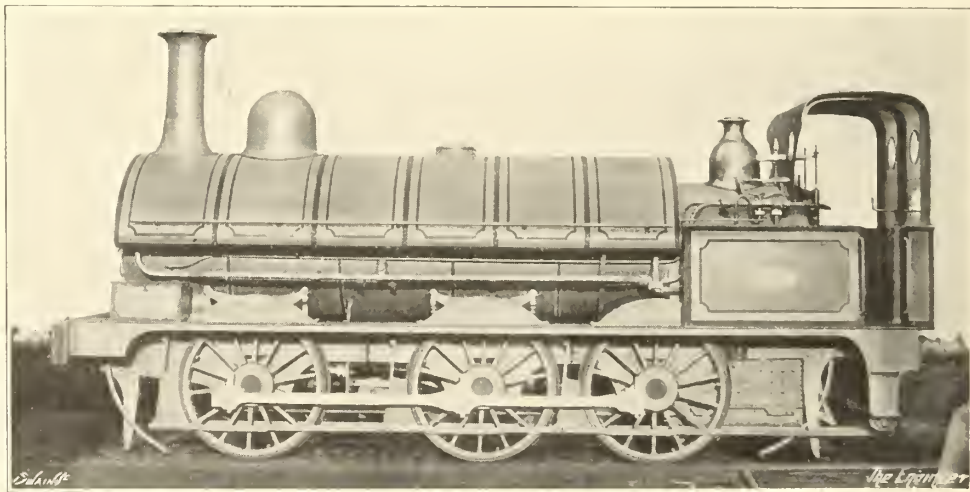

FIG. 225—SHARP, STEWART & CO.'S TANK ENGINE FOR THE BRECON & MERTHYR RLY., 1865-68

blast, and therefore great cylinder power was necessary as a reserve. The cylinders, 20in. by 24in., the largest of that day, were inclined at 1 in $8\frac{1}{2}$. The valves were on the top and were actuated by rocking shafts and Allan's straight

capacity, 1100 gallons; weight loaded, 38 tons.

Some banking engines for the Furness Railway, built 1868-73 by Sharp, Stewart and Co., to their own designs, had very long side tanks, cut away to provide access to the motion. The cylinders

were 18in. by 24in.; wheels, 4ft. 6in. diameter; total heating surface, 1144 square feet; grate, 15 square feet; pressure, 145 lb.; weight loaded, 41 $\frac{3}{4}$ tons. The iron frames were 1 $\frac{1}{4}$ in. thick and the Yorkshire iron boiler plates $\frac{1}{2}$ in. thick. The crank axles were of Bessemer steel.

Six-coupled Passenger Tank Engines.—In 1868 the North British Railway followed the lead of the Lancashire and Yorkshire in the use of 0-6-0 saddle-tank engines for local passenger services, and a considerable number were built at Cowlairston from 1868 to 1873. It is unnecessary to illustrate these engines, which presented no features of special interest. The saddle tanks extended from the back of the smoke-box to the back of the fire-box casing. The cylinders were mostly 16in. by 24in.—though a few had 22in. stroke—and the coupled wheels, which had inside bearings only, were 5ft. in diameter. Pressure 130 lb.; weight in working order, about 36 $\frac{1}{2}$ tons. These engines were designed by Mr. Wheatley, then locomotive superintendent.

DETAILS.

During this period (in 1868, according to W. P. Marshall) frame plates were supplied in one piece from the rolling mills, after which welded frames disappeared. Adams's method of attaching the cylinders and also his sliding bogie have already been mentioned.

Boilers.—The fire-box with direct roof stays in place of girders made its appearance in W. Bouch's Stockton and Darlington engines, but it is by no means certain that these were the first engines in this country to have this method of staying. It had previously been employed in Belgium and France, and direct stays in combination with roof girders had been used in America. According to the late Edward Reynolds direct stays had been used in some of the earliest Great Northern engines, the date of which was not given.

In 1866 Dudgeon's tube expander, an American invention, was introduced into this country. The tubes were secured by a shoulder and the end beaded over by the same tool. It was first tried on the North London Railway by W. Adams, to whom Zerah Colburn gave a sample.

Motion, &c.—Early in 1866 Ramsbottom applied bush ends to the coupling rods of the 2-4-0 engines previously described. This simplification, which dispensed with brasses and cotters, was almost immediately taken up by most locomotive engineers, largely to avoid the trouble caused by drivers who persisted in hammering the cotters down. Though others applied bushes to the rods of six-coupled goods engines, Ramsbottom himself confined them strictly to four-coupled passenger engines, and in all his goods engines used brasses and cotters. It was not until 1873 that F. W. Webb applied bushes to the six-coupled engines of the L. and N.W.R. On the G.W.R. J. Armstrong, between 1868 and 1876,

compromised by fitting bushes to the crank pins of the leading and trailing wheels only, retaining cotted brasses for the driving pins. Ramsbottom and Kirtley used bronze bushes. Adams and McDonnell used cast iron lined with white metal, and after 1873 Webb forced solid white metal bushes into the coupling rods.

Joseph Beattie's semi-circular balanced slide valve was at this period applied to many of the L. and S.W.R. express engines. The valves were of hard cast iron with two cast iron packing rings, and, though somewhat complicated, were very successful.

The convenience in "notching up" with the screw reversing gear induced several designers to combine a screw with the reversing lever for the purpose of reversing quickly, and also of putting the engine into full gear immediately steam was shut off. W. Bouch's arrangement of 1865¹ used on a number of N.E.R. engines, consisted of a torpedo-shaped screw on which a square thread was cut. The catch of the reversing lever could be moved into or out of the continuous notch formed by the screw thread. This reversing gear was applied by R. Stephenson and Co. to a considerable number of engines.

A different design for an engine by Sharp, Stewart and Co. is shown in Plate XXIV. of Colburn's "Locomotive Engineering." The boss of the reversing wheel had a trunnion nut attached, which was pivoted on a pin at the back end of a plain sector. The reversing screw passed through the lever in such a way that a half nut attached to the trigger rod could be made to engage in the thread, in which case the lever moved slowly as the hand wheel was rotated. In mid-position the screw was horizontal, but the position of the trunnion pivot was such that as the lever moved into fore-gear the screw and wheel turned through an angle about the pin and the screw assumed a position inclined downwards towards the front. In back gear the inclination was upwards towards the front. This arrangement was invented about 1862-63 by M. Belpaire and was applied to nearly all the locomotives of the Belgian State Railways. Edward Fletcher, on the N.E.R. express engine, used a modification of Bouch's gear mentioned above, but there were very few other applications of the combined lever and screw on British railways.

Fire-box Water Tubes.—In 1868 James Pearson, of the Bristol and Exeter Railway, applied water tubes to the fire-boxes of the reconstructed 4-2-4 tank engines—Fig. 127 *ante*. There were five tubes, each about 4in. internal diameter, placed transversely in an inclined position. Upon these brickwork rested, forming a flattened arch. The tubes were screwed at both ends into an angle collar, the latter being riveted to the fire-box sides.

¹ Illustrated in "A Century of Locomotive Building," by J. G. H. Warren (face p. 371), and in "The Development of British Locomotive Design," by the writer.

There do not appear to have been any facilities for cleaning the tubes, which were removed after a few years' service.

In 1861 R. Stephenson and Co. designed a boiler for the Metropolitan Railway, with a long

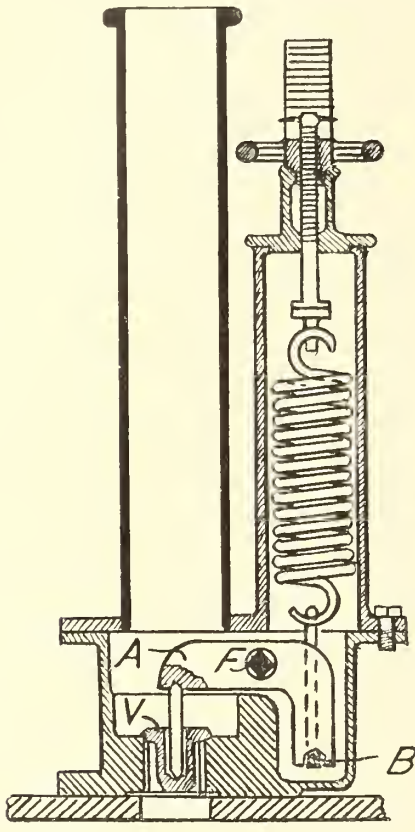

FIG. 226—NAYLOR'S SAFETY VALVE

circular combustion chamber having 250 transverse water tubes $1\frac{1}{4}$ in. diameter. This boiler does not appear to have been made.²

Safety Valves.—The Naylor safety valve—Fig. 226—introduced about 1866 by Kitson and Co., was for some years standard on the Lancashire and Yorkshire and the North-Eastern railways. Its object was to overcome the defect of the increased force on the back of a direct spring-loaded valve as the latter lifted and compressed the spring. The spindle of valve V acted on the end A of a bent lever, the other end B of which was attached by a stirrup to the spring. As the valve lifted the horizontal distance between the spindle and the fulcrum F decreased only very slightly, but the end B, was by its rotation brought very much nearer to the vertical line through F, and the leverage on this side considerably decreased. Therefore the moment of the force lifting the valve remained practically constant, whilst the opposing moment exerted by the spring

² Described and illustrated in the "Chronicles of Boulton's Siding," by A. R. Bennett.

was greatly lessened. For a time these valves bid fair to rival the Ramsbottom duplex valves, but the latter had the advantage that the driver could ease them regularly by using his lever, whereas the enclosed Naylor valves, in case of sticking, were inaccessible.

Blast Pipe.—It is perhaps in the fitness of things that the Stockton and Darlington Railway, on which Hackworth's contracted nozzle first appeared, should have been the line upon which one of the most extraordinary designs of blast pipe was tried by W. Bouch. This arrangement—Fig. 227—which bore some sort of resemblance to a church organ, had two objects in view, viz., to produce a continuous instead of intermittent blast, and to give greater surface of jet for entraining the gases. The exhausts entered a rectangular chamber to which two bent pipes with closed ends were attached. The action of these reservoirs was presumably intended to be similar to that of the air vessel of a pump. The blast pipe or pipes took the form of a number of open-

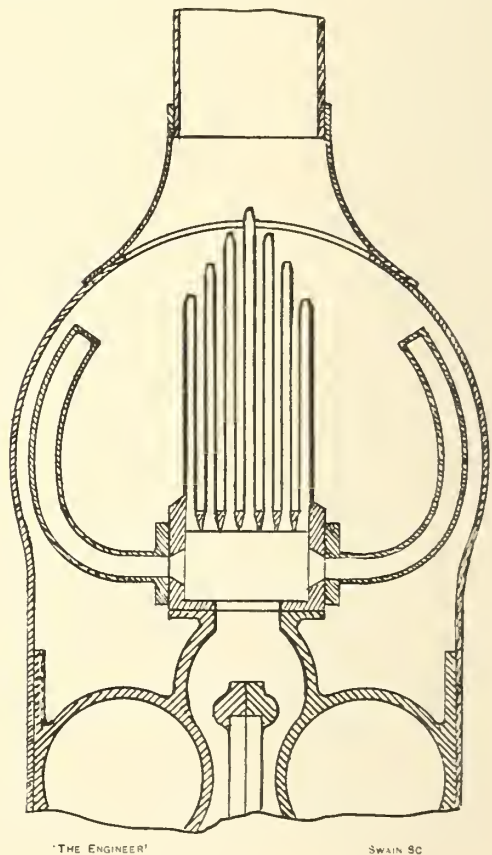

FIG. 227—W. BOUCH'S BLAST PIPE, STOCKTON AND DARLINGTON RAILWAY

mouthed tubes of different heights, through which the steam was discharged continuously into the chimney.

It is interesting to observe that the old piston plug theory of the action of the steam in the

chimney was by no means held by all engineers. J. A. Longridge in 1852 pointed out before the North of England Mining engineers that the effect of the jet of steam was a frictional action between the surface of the jet and the surrounding air.

Sand Boxes.—W. Adams in the North London engines placed a single sand box on the boiler. The outlets were arranged in a horizontal base plate, and each was closed by a cone at the bottom of a vertical rod actuated by lever gear from the footplate. Cudworth on the S.E.R. also began to place the sand box on the boiler for the purpose of keeping the sand dry. In this case a square box surrounded the base of the dome. Sand boxes on the boiler have never found favour in this country, owing to the tendency to spill sand, which finds its way to the motion.

Cabs.—The elaborate "American" cab on Stephenson's engine of 1860 (Fig. 186 *ante*) might be expected to have been received with favour, but that was far from being the case. There were two obstacles. Many locomotive superintendents considered that if drivers were made too comfortable some were prone to fall asleep on duty, but it is

L.R., adopted the completely covered over footplate about 1865, supported the bent weatherboard by columns, and retained it until 1877 in spite of the "drumming."

The early Great Western experience with iron-roofed cabs, of which a number were applied in 1872-73, was similar to that of the Midland. The drivers objected to the rattling and a return was made to the old straight front weatherboard, which gave hardly any protection whatever. Later G.W.R. cabs from 1876 onwards had roofs with wood battens. P. Stirling built no engines after 1863 without cabs, but their use on most railways was deferred until about 1870-77, according to the particular views held by the different locomotive superintendents. It was not until 1886 that the Stephenson "American" cab of 1860 was re-introduced by T. W. Worsdell on the N.E.R.

LOCOMOTIVES FOR IRELAND AND OVERSEAS, 1860-69.

Ireland.—With very few exceptions, locomotives in Ireland were similar in general design to

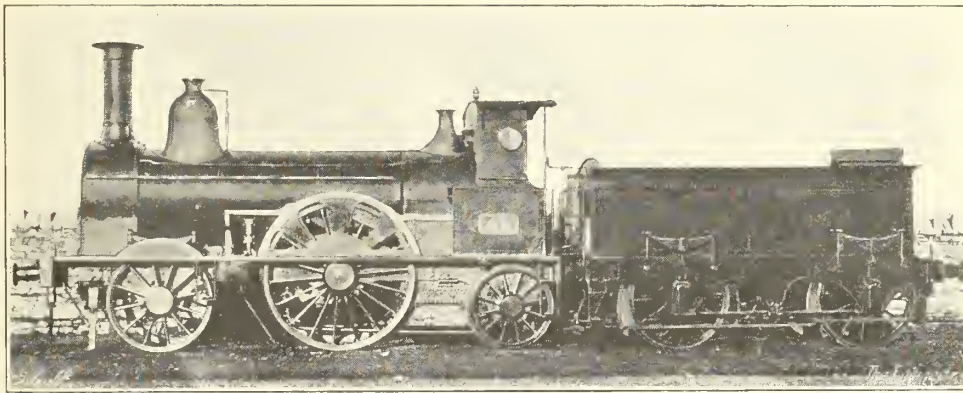

FIG. 228—J. WAKEFIELD'S G.S. & W. RAILWAY EXPRESS ENGINE, 1858-63 [Photo. Locomotive]

also true that the drivers themselves objected to being closed in. They were a hardy lot in those days. The usual protection consisted merely of a flat weatherboard placed at the back on the top of the fire-box casing. On the Midland Railway in 1863 some boys threw bricks down from an overbridge at Loughborough, severely injuring a driver, after which M. Kirtley gave better protection by bending the top of the weatherboard completely over the footplate, supporting it at the back by means of two columns. This form of weatherboard rattled when the engine was running, and the twenty engines or so fitted with it were known as the "drummers." The drivers objected strongly to it, and asked for its removal. A compromise was reached whereby the weatherboard was bent over part only of the footplate and was not supported by pillars. This arrangement, shown in Fig. 216 *ante*, was standard on the Midland until 1872. Sacré, on the M.S. and

those on this side of the Irish Channel, though of smaller size, since train loads were lighter. The cylinders were in nearly all cases inside. The majority of the main line "single" engines were of what may be termed the "McConnell" type, with all bearings inside the frames. The first engine built in Ireland in 1845 at the works of Grendon and Co., Drogheda, for the Dublin and Drogheda Railway, was of that type. An express engine of the Great Southern and Western Railway, built at the Inchicore works of the company, during the 1858-63 period, to the designs of John Wakefield, is shown in Fig. 228. The cylinders were 15in. by 22in., and the driving wheels 6ft. 6in. diameter. As in McConnell's engines, the leading wheels were of large size, 4ft. 6in. diameter, but the trailing wheels were only 3ft. 8in. diameter. But the engines differed in that the wheel base, 14ft. 10in., was shorter.

A number of 2-2-2 engines of similar type, but

of neater design, were built by Beyer, Peacock and Co., for the different railways which afterwards were amalgamated into the Great Northern Railway of Ireland in 1876.

Most of the 2-4-0 engines, with the exception

extremely like Ramsbottom's engines on the L. and N.W.R., but differed from the latter in that the fire-box casing was raised slightly above the barrel, and the valve motion was of the suspended swing link type, instead of having rectangular

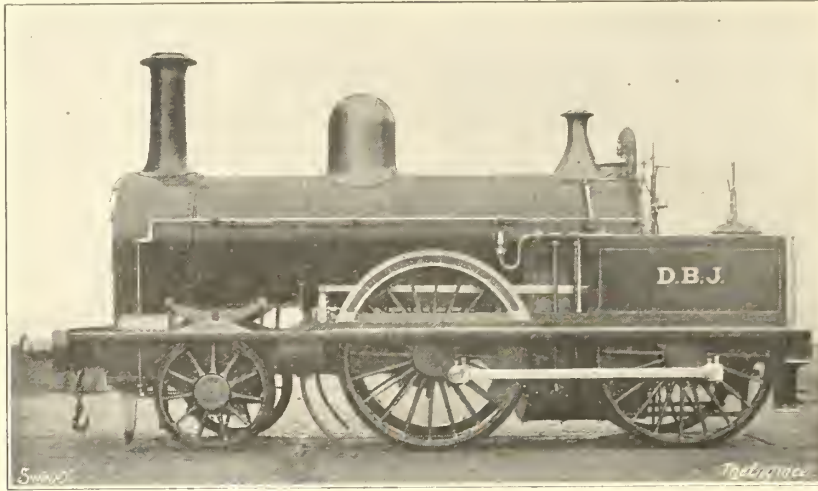

FIG. 229—BEYER, PEACOCK & CO.'S ENGINE FOR THE DUBLIN & BELFAST JUNCTION RLY., 1866

of some on the Ulster Railway, and on the Belfast and Northern Counties Railway, also had inside bearings throughout. Fig. 229 shows a standard design by Beyer, Peacock and Co., 1866, for the Dublin and Belfast Junction Railway. The engines had 6ft. coupled wheels and 16in. by 22in. cylinders, whilst others of the same general design for the Dutch State Railways, 1864-72, of which there were sixty, were somewhat smaller, with 5ft. 6in. coupled wheels and 16in. by 20in. cylinders.

In 1869 Alexander McDonnell designed a number of 2-4-0 express engines, also of the type with inside frames throughout, for the Dublin-

valve spindle guides. The total heating surface was 931 square feet, of which the fire-box provided 96 square feet. The grate area was 17½ square feet and the weight in working order 30 tons 0 cwt. 2 qr.

Goods engines were mostly of the 0-4-2 type, with inside frames, 5ft. coupled wheels, and 16in. cylinders, having 22in. or 24in. stroke. The use of these engines was almost universal throughout Ireland, though a number of 0-6-0 engines, with 17in. by 24in. cylinders, were placed in service from 1867 onwards. Sectional drawings of one of John Wakefield's 0-4-2 engines on the Great Southern and Western Railway are given in

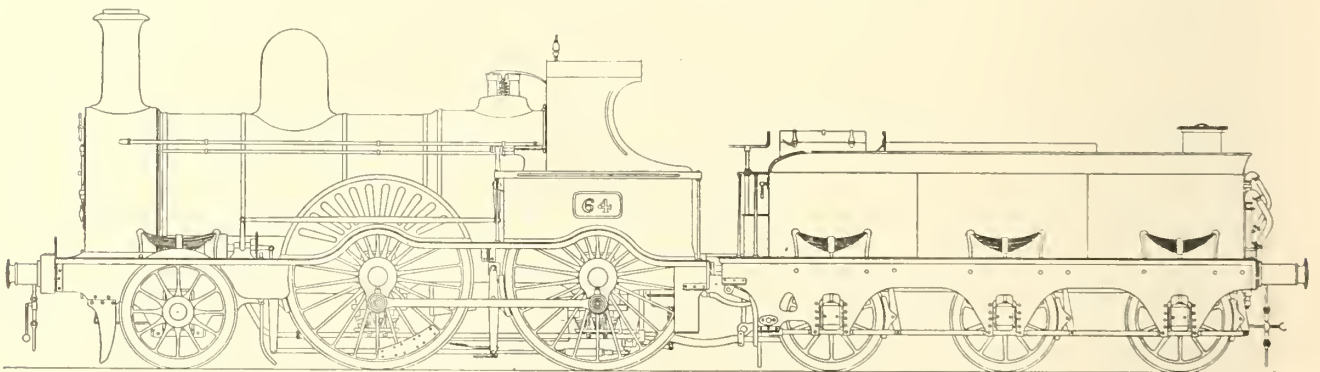

FIG. 230—A. McDONNELL'S PASSENGER ENGINE, GREAT SOUTHERN & WESTERN RLY., 1875

Cork services of the Great Southern and Western Railway. They had 6ft. 7in. coupled wheels and 16in. by 22in. cylinders, increased to 17in. by 22in. in the later engines of 1875. One of the latter is illustrated by Fig. 230. In appearance they were

Colburn's "Locomotive Engineering," Plates 34 and 35, and one of Neilson's engines for the Dundalk and Enniskillen Railway is illustrated in Fig. 231.

Owing to the width of the Irish gauge—5ft. 3in.

—double frames with outside bearings were uncommon, except on the railways in the north of Ireland, since sufficiently long bearings could be obtained with inside frames only. An exceptional

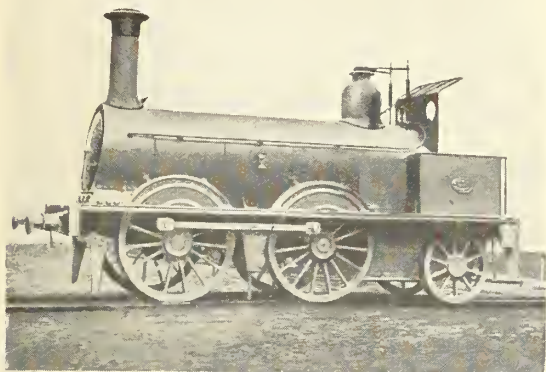

FIG. 231—NEILSON'S 0-4-2 GOODS ENGINE FOR THE DUNDALK & ENNISKILLEN RAILWAY

instance is afforded by the 0-4-2 engines—Fig. 232—of which four were built in 1866 by Beyer, Peacock and Co. for the Ulster Railway, with 5ft. coupled wheels, 3ft. 6in. trailing wheels, and 17in. by 24in. cylinders. They are interesting in that they were the last 0-4-2 goods engines with double frames of the old Stephenson type of 1833 to be constructed in this country. The much more modern framing and general details and fittings of these engines were characteristic of Beyer, Peacock's practice.

This type has already been mentioned and need not be further considered.

The type of 0-4-4 back tank engine—Fig. 233—built in 1869-70 at Inchicore Works, to A. McDonnell's designs, was a novel departure, and merits special mention. It was what may be termed a single Fairlie with front coupled wheels, which formed a steam bogie. The hind bogie was of the Adams type, with lateral movement and india-rubber pad. The pivot of the steam bogie had a flat face, which rested in a recessed socket. Though nearly all the weight was carried on the pivot, there were also india-rubber load check springs on each side in a cup bracket attached to each main carrying frame. This arrangement allowed the steam bogie and carrying frame to tilt together laterally, whilst the trailing Adams bogie could also tilt independently of the main frame. The pitching movement of the steam bogie was controlled by rubber check springs fixed to a bracket carried centrally on the transverse stay in front of the fire-box. The springs of the coupled wheels were connected by compensating levers, and the trailing bogie had a single inverted spring on each side. The steam pipe, 3in. diameter, was taken out from the front of the dome into a tee piece, from which two external pipes passed round the boiler to a tee joint underneath on the centre line of the engine. From this joint a single bent pipe conveyed the steam to the valve chest between the cylinders. The elasticity of the pipes and bends was relied upon to accommodate the movements of the steam bogie, and there was no swivelling joint as in modern articulated engines. The blast pipe was provided with a petticoat pipe, the lower mouth of which

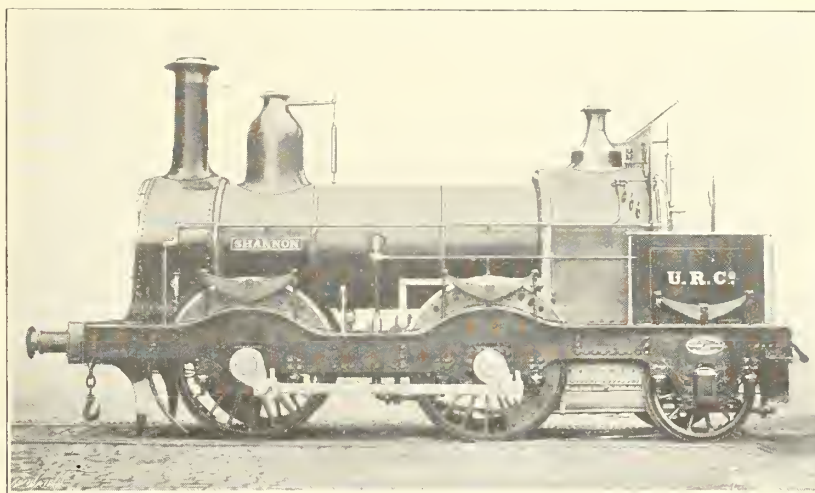

FIG. 232—BEYER, PEACOCK & CO.'S ENGINE FOR THE ULSTER RLY., 1866

Of passenger tank locomotives there was a considerable number of 2-2-2 engines of the "Fairbairn" type with inside bearings for all wheels, principally on the Dublin, Wicklow and Wexford and Midland Great Western railways.

was large enough to allow the bottom portion of the pipe to move within it.

The cylinders were 15in. by 20in. and the coupled wheels 5ft. 7½in. diameter, had a wheel base of 6ft., the pivot being 2ft. 7in. in front of

the driving wheel. The trailing bogie wheels, 2ft. 11in. diameter, had a 5ft. wheel base. The distance between bogie centres was 14ft. 7in.; total wheel base, 20ft. 6in.; weight on steam

which the 5ft. 6in. gauge allowed for longer bearings and wider crank webs. The change may have been in part due to the influence of Robert Sinclair, who acted as consulting engineer for the

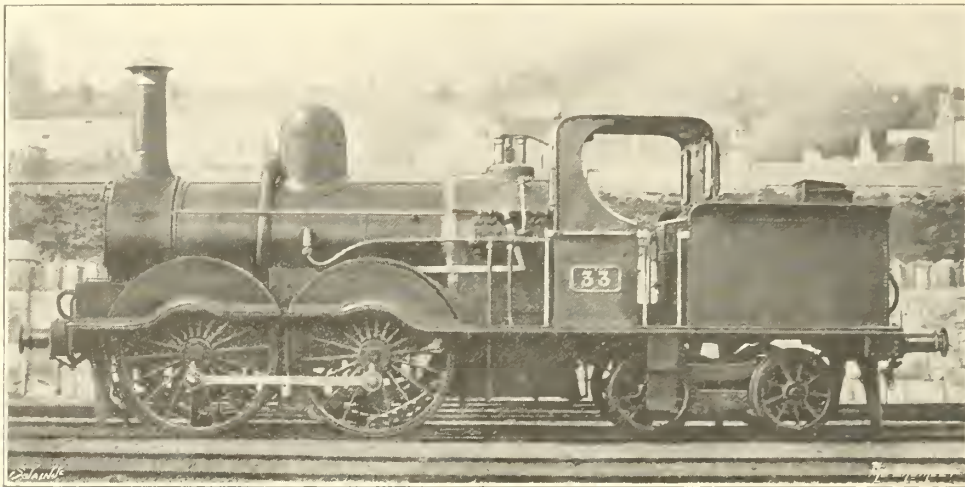

FIG. 233—A. McDONNELL'S FAIRLIE TANK ENGINE, G.S. & W.R., 1869

bogie, 22 tons; total weight, 35 tons 17 cwt.; water tanks, 800 gallons; fuel, 30 cwt. Sections of these engines are shown in Colburn's "Locomotive Engineering," plate 47.

Only two of these Fairlie engines were built. Whether the steam pipes gave trouble the writer does not know definitely, but in a large number of 0-4-4 tank engines, which were built subsequently at Inchicore between 1871 and 1884 on somewhat similar lines, the steam bogie was suppressed, and the leading coupled wheels were arranged with bearings in the main frames in the usual manner. In the latter engines, one of which is illustrated in Fig. 234, the trailing bogies were provided with outside bearings.

India.—A few of the more interesting types

designs, and who was an out-and-out advocate of outside cylinders. Of the two designs mentioned below the drawings were, the writer believes, prepared by the late Dr. W. H. Maw.

The 2-2-2 "mail" engines were built by the Vulcan Foundry, Neilson, and Beyer, Peacock, 1862 to 1865. Cylinders, 15in. by 22in.; wheels, 3ft. 9in. and 6ft. 6in.; wheel base, 6ft. 8in. + 8ft. 2in.; total heating surface, 1109 $\frac{3}{4}$ square feet; grate area, 18 square feet. The footplate was protected by an arched roof.

No less than 285 2-4-0 mixed traffic engines were built from 1861 to 1868, and were for many years standard for all passenger and goods services on the East Indian Railway, except the mails and faster expresses. The cylinders were 16in. by

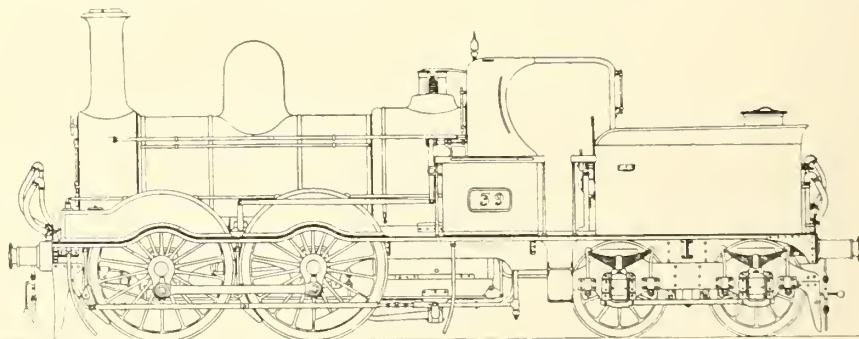

FIG. 234—A. McDONNELL'S TANK LOCOMOTIVE, G.S. & W.R., LATER DESIGN, 1871-84

built for Indian railways may be briefly mentioned.

In 1861 the East Indian Railway adopted engines with outside cylinders in place of those with inside cylinders previously used, in spite of the advantage

22in.; wheels, 3ft. 7in. and 5ft. 7in.; wheel base, 15ft. 4in.; heating surface of tubes, 1009 square feet, of fire-box 97 square feet; total, 1106 square feet. In this connection it may be added that the tubes of most of the class were 2 $\frac{1}{4}$ in. outside

diameter, although their length was only 10ft. 11in. Pressure, 120 lb.; weight in working order, 32 tons 14 cwt., but the distribution on the coupled wheels was very unequal, as the driving pair

Helens, also made thirty in 1866-67. The first locomotives built for India by Continental firms were included in the class. Of these twenty were made by E. Kessler, of Esslingen, one of which

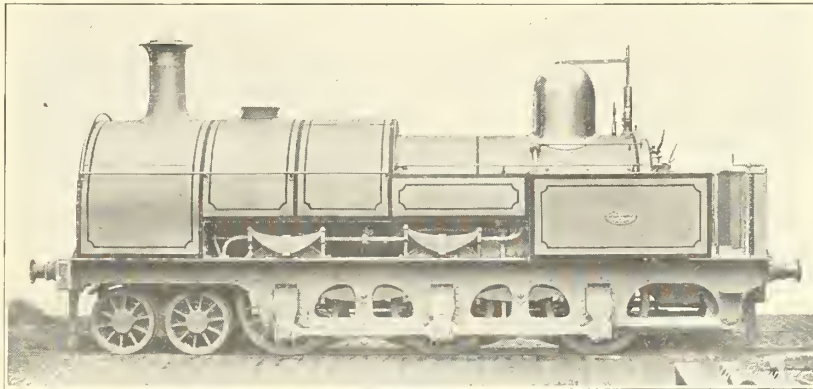

FIG. 235—SHARP, STEWART & CO'S GHAT ENGINE, G.I.P. RAILWAY, 1862

carried 12 tons 11 cwt. and the trailing pair only 8 tons 13½ cwt.

The above dimensions have been taken from those published by D. K. Clark relating to the engine by Armstrong and Co. in the London 1862 Exhibition. Kitson's drawings show a wheel base of 6ft. 2in. + 8ft. 8in. = 14ft. 10in., and a total weight of 31 tons 12 cwt., of which 12½ tons rest on the drivers and 9 tons 4¼ cwt. on the trailing wheels.

Incidentally some new locomotive manufacturers took part in the building of these engines, in addition to the old-established firms of Kitson, Hawthorn, Avonside Engine Company, and the Canada Works. Amongst the newcomers were W. G. Armstrong and Co., of Newcastle, who showed one at the 1862 Exhibition. After

was at the Paris Exhibition of 1867, and ten others came from the works of Escher Wyss and Co., of Zurich.

Although a limited number of 2-4-0 outside cylinder engines were built from 1866 to 1870 for other Indian main lines, the type was not perpetuated, and the standard British inside cylinder engines of the period, mostly of the 2-4-0 and 0-6-0 types, formed the great majority of those sent to that country.

The mixed traffic engines of the Scinde, Punjab, and Delhi Railway, afterwards the North-Western State Railway, were of the 0-4-2 type. They had 17in. by 24in. cylinders and 5ft. 6in. front coupled wheels. All were built by Stephenson and Kitson, 1867-70.

Other engines for India described below never

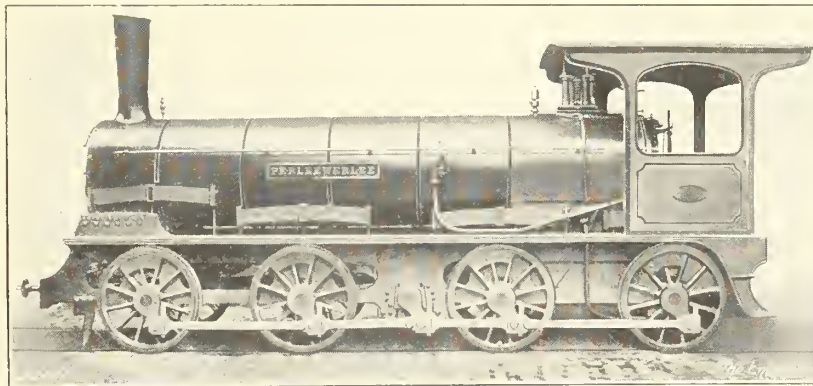

FIG. 236—SHARP, STEWART & CO'S ENGINE FOR THE OUDH AND ROHILKHUND RLY., 1865

building about twenty Armstrong's gave up locomotive work, to reappear in 1919 in this branch of engineering. Another Newcastle firm, J. Morrison and Co., built ten in 1867, and then disappeared completely. Cross and Co., of St.

building about twenty Armstrong's gave up locomotive work, to reappear in 1919 in this branch of engineering. Another Newcastle firm, J. Morrison and Co., built ten in 1867, and then disappeared completely. Cross and Co., of St.

Railway, to replace the back-to-back twin engines previously used. Sectional drawings appear on Plate VI. of Colburn's "Locomotive Engineering," but, so far as the writer is aware, no outside view which shows the peculiar arrangement of

wide gauge, it was possible to place the steam chests between them. Other dimensions were:—Coupled wheels, 4ft. 4in.; bogie wheels, 2ft. 9in.; coupled wheel base, 12ft. 10in.; total base, 19ft. 10in.; the driving tires were flangeless; total

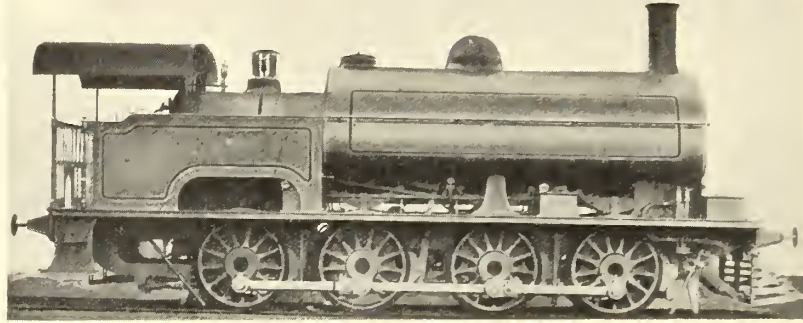

FIG. 237—EIGHT-COUPLED SADDLE TANK LOCOMOTIVE FOR THE G.I.P.R.L.Y., BY NEILSON & CO., 1879

saddle tanks has hitherto been published. The main outside frames were of the old sandwich type, and the writer believes that these were the only engines ever built for the Indian broad gauge with outside frames and cranks. Other peculiarities included the sledge brakes, compensating levers producing three-point suspension for a ten-wheeled engine, and a bogie with the ridiculously short wheel base of 3ft. 2in. for a 5ft. 6in. gauge line. This bogie could slide laterally under the engine, and appears to have been the first made in this country with this arrangement, but unlike Adams's bogie which followed, the controlling

heating surface, 1438 square feet; grate area, 25.9 square feet; weight on coupled wheels, $37\frac{1}{2}$ tons; total weight, 49 tons.

The peculiar eight-wheels coupled engines with intermediate driving shaft—Fig. 236—were made in 1865 by Sharp, Stewart and Co., for an "Indian Branch Railway," later the Oudh and Rohilkhund. They were built under James E. Wilson's patent, which if it included the intermediate shaft, was one of those perennial "improvements" which kept the Patent Office of that day out of other mischief. The driving wheels were 4ft. in diameter, and the $16\frac{1}{2}$ in. by

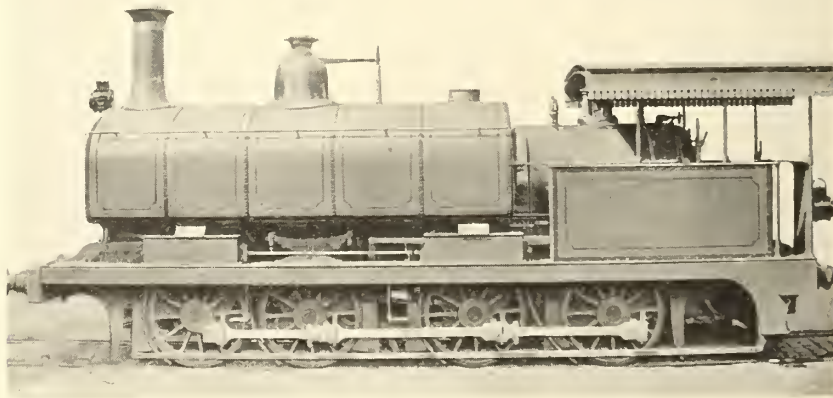

FIG. 238—EIGHT-COUPLED SADDLE-TANK ENGINE FOR THE MAURITIUS RAILWAYS, BY SHARP, STEWART & CO., 1867

force was supplied by inclined planes, as in Bissell's trucks. The cylinders were 20in. by 24in., the first to be made of that size for a British built locomotive, antedating those of the St. John's Wood engines by five years. Owing to the

24in. inside cylinders were steeply inclined. The crank shaft bearings had adjusting wedges both in front and behind, and the axle-boxes of the end pairs of wheels had $1\frac{1}{2}$ in. lateral movement in the guides, the coupling rod pins being long

enough to allow for it. The springs were cambered slightly upwards, the plates being of the same length but tapering in width from the middle to the ends. They were also of the "open-plated" form, that is, a thin packing plate was inserted between each main plate at the buckle, so that the ends were not in contact with each other. This construction was adopted to bring the plates into action successively. The axle bearings were 9in. long and only $5\frac{1}{4}$ in. diameter. The chimney top was bevelled from front to back, and a central buffer only was provided. The engine, which was built for light rails, weighed only 30 tons.

The heavy 0-8-0 tank engines for the Ghât inclines of the G.I.P.R., superseded the 4-6-0 tank engines described earlier from 1866 onwards, when the first twenty were built by Kitson. They had inside cylinders 18in. by 24in. and 4ft. wheels. This remained the standard type for

chief locomotive superintendent of the railway. They were American in all essentials except that shallow plate frames instead of bar frames were employed, and the fire-box casings were flush with the barrel. The bogie was of the trussed diamond truck pattern without side play, and with no other springs beyond a block of india-rubber on the flat centre plate, and two small rubber springs at the sides of the transverse beam. The bogie wheels were of chilled cast iron; the fire-box of wrought iron, but the tubes of brass. The chimney was of flattened "diamond stack" type, with spark arresting top 6ft. diameter. The weigh-bar shaft was counterbalanced by a coiled spring. These engines had 16in. by 26in. cylinders and 5ft. 1in. coupled wheels.

The extremely neat 4-4-0 engines by Fox, Walker and Co., 1868, for the Windsor and Annapolis Railway, Nova Scotia, are illustrated

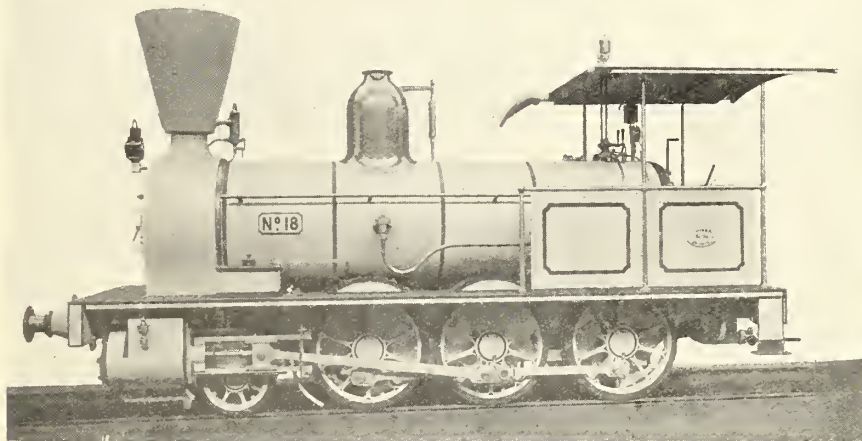

FIG. 239—KITSON'S ENGINE FOR QUEENSLAND, 1866

about thirty-five years, though in the later engines the stroke was increased to 26in. In all, about 85 of the class were built by Kitson, Neilson, and Vulcan Foundry, a few of them being supplied to the North-Western State Railway. An engine of this class built by Neilson and Co. in 1879 is illustrated by Fig. 237.

The somewhat similar 0-8-0 tank engines for the Mauritius Railways—4ft. $8\frac{1}{2}$ in. gauge—also with inside cylinders, 18in. by 24in., built in 1867 by Sharp, Stewart, is illustrated in Fig. 238. These engines had a total wheel base of 15ft. 6in., and the end axle-boxes had a lateral play of $\frac{1}{4}$ in. each way.

OTHER LOCOMOTIVES FOR OVERSEAS.

In 1868 Neilson and Co. built 25 4-4-0 American type engines for the Grand Trunk Railway, Canada—at that time of 5ft. 6in. gauge—to the drawings and templates provided by R. Eaton,

in "Colburn," plate 46. With the exception of the polished mahogany American type cabs they were of British design throughout. The principal detail of interest was the spring gear, in which a very large number of rubber washers were interposed between the adjusting nuts and the frame brackets and compensating levers. The coupling rods had circular bushes of steel.

As the Bissell two-wheeled truck did not appear in this country until 1860, whereas the four-wheeled bogie was made for engines exported to America in 1833, the 2-6-0, or "Mogul," engine was of considerably later date over here than the 4-6-0 type. The latter had been built for South America by Hawthorn in 1860, but as far as the writer can trace, the first 2-6-0 locomotives built here were 3ft. 6in. gauge engines made by Neilson and Kitson in 1866-69 for the Queensland railways—Fig. 239. The first 2-6-0 engines for a British railway did not appear until 1878.

The type of 2-4-0 tender engine—Fig. 240—

which was built in 1862 by Beyer, Peacock and Co., for the Tudela and Bilbao Railway (Spain), of 5ft. 5 $\frac{3}{4}$ in. gauge, is one which was never used on any British railway. The leading axle formed a Bissel truck, controlled by inclined planes, but instead of the inclination of 1 in 6 which proved unsatisfactory on Sinclair's Great Eastern tank engines, the more moderate inclination of 1 in 11 was provided. These engines, which were built

for mixed trains at very moderate speeds, over a road with many curves, had a wheel base of 10ft. +8ft. The cylinders were 16in. by 24in., and the driving wheels were 5ft. diameter; weight in working order about 29 $\frac{1}{4}$ tons. Several are still in service in the locomotive stock of the Northern Railway of Spain, but the compensating levers between the springs of the coupled wheels have been removed.

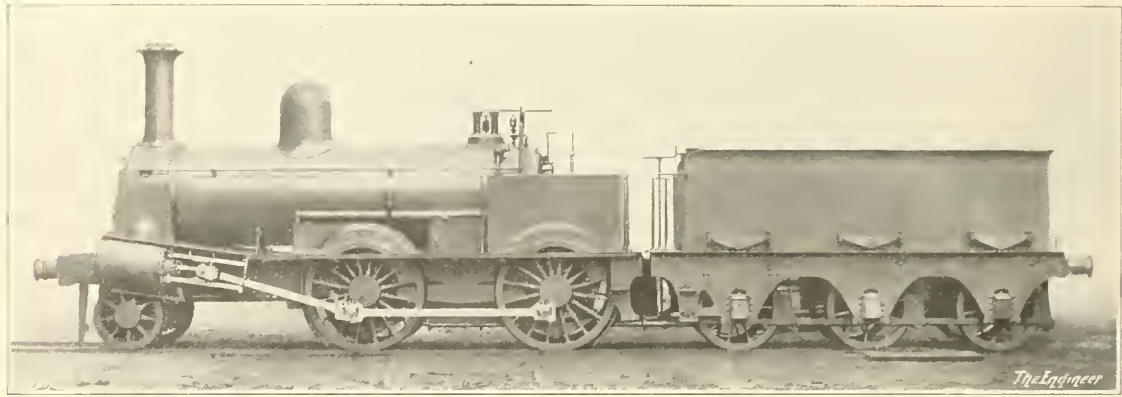

FIG. 210—BEYER, PEACOCK & CO.'S ENGINE FOR THE TUDELA AND BILBAO RAILWAY, 1862

Chapter XIV—1870-75

EXPRESS ENGINES WITH "SINGLE" DRIVING WHEELS.—During the period 1870 to 1875 only two railways, the Great Northern and the Great Western, continued the regular construction of engines with uncoupled wheels. To these there should be added the London, Brighton and South Coast Railway, on which single engines were not yet abandoned, except for the heaviest expresses, though only one engine of a new class was constructed at this time. The engines of all three railways were of different types.

The most notable of the new engines were P. Stirling's celebrated 4-2-2 "singles," with 8ft. driving wheels, outside cylinders and leading bogies—Fig. 241. These engines may be described as one of the boldest departures made at that time from what was then considered orthodox practice. Stirling had always been an advocate of single engines, and in 1866, immediately before his departure from the Glasgow and South-Western Railway, had constructed six-wheeled

introducing the bogie in order to improve the "curving" property of the engine, for the Great Northern has a very straight main line. Stirling had no great affection for leading bogies, and the 8ft. singles were the only locomotives with them which he ever built. The bogie was of the rigid centre pin pattern, without lateral movement, but the pin, instead of being placed midway between the front and hind axles, was behind the centre line, and divided the bogie base into 3ft. 6in. + 3ft. With this arrangement the leading wheels followed the curve better with less tendency for the main frame to pull the bogie back towards the outside, and, further, the weight coming on to the rails was increased progressively. As Mr. Stirling subsequently expressed it, the bogie gradually laid down the road so that the driving wheels got hold of it. The pivot carried only a very small proportion of the load, most of which was supported on two side bearings, each consisting of a channel-shaped bracket which embraced the bogie frame. The main frame, which, when

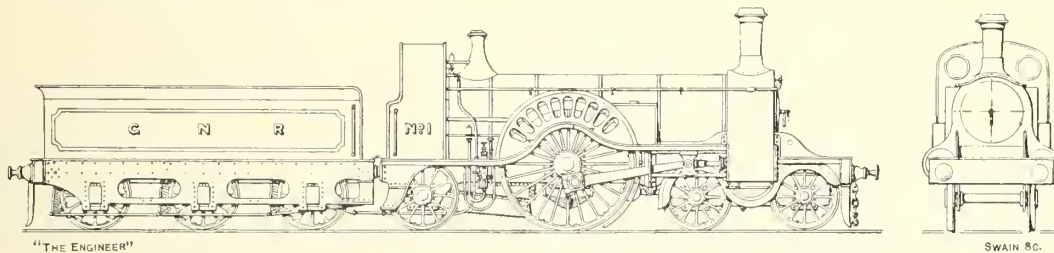

FIG. 241—P STIRLING'S EXPRESS LOCOMOTIVE, GREAT NORTHERN RAILWAY, 1870

engines of that type with outside cylinders and 7ft. driving wheels, though he subsequently returned to inside cylinders in his first Great Northern engines of 1868. For the new and more powerful engines he chose the large driving wheel diameter of 8ft. 1in., on the ground that the larger the wheels the better their adhesive grip on the rails. Owing to the use of 80 lb. steel rails on the main line, the weight on the driving wheels was brought up to 15 tons. But the use of such large wheels compelled the designer to use outside cylinders, and these were the only engines constructed by him for the Great Northern in which that position of the cylinders was adopted. Each cylinder was held in an opening in the frame, which was closed below by means of a piece formed like a hornplate stay. The steam chests were vertical and placed inside the frames. The cylinders, 18in. diameter by 28in. stroke, were horizontal, and to avoid the cylinder overhang and short wheel base, compulsory in a six-wheeled engine, a leading bogie was employed. Its wheel base was 6ft. 6in. There was no question of

the bogie was central, lay in the same vertical plane as the vertical frame, rested on a sliding foot which could move laterally inside the channel of the bracket. The diameter of the bogie wheels was 3ft. 11in. and of the trailing wheels 4ft. 1in.; engine wheel base, 6ft. 6in. + 7ft. 9in. + 8ft. 8in. = 22ft. 11in. The trailing axle had $\frac{3}{4}$ in. lateral play in the hornblocks, and the weight at that end was carried on volute springs.

The boiler was of the domeless type, with an internal steam collecting pipe, and was pressed at 140 lb. per square inch. It was of Lowmoor iron and contained 217 brass tubes, $1\frac{9}{16}$ in. diameter. The fire-box had a transverse inclined copper water mid-feather instead of a brick arch, which, in effect, was somewhat similar to the French Ten-Brinck arrangement, but extended from side to side between the water spaces, instead of being connected to the latter by bent pipes. This arrangement, which was subsequently abandoned for the usual British type of brick arch, increased the fire-box heating surface to 122 square feet. The total heating surface was 1165 square feet,

and the grate area 17.6 square feet; weight in working order, on front bogie wheels 7 tons, hind bogie wheels 8 tons, driving wheels 15 tons, trailing wheels 8 tons 9 cwt., total 38 tons 9 cwt.

These engines were not built in batches of ten or more, as is the usual practice. They came out from the works at intervals, one or two at a time, beginning with the first engine, No. 1 of 1870. By the end of 1875 only twelve were in service, though at the end of 1895 there were fifty-three of the type. They performed by far the greater part of the main line express service until the end of the nineteenth century, but in the later years they shared the work with another type of single engine to be mentioned subsequently. There were modifications in details in the later 8ft. engines, which it will be convenient to mention here. From about 1884 the trailing wheels were increased to 4ft. 7½in. diameter, and the cast iron foot-plate

by 28in. as before, though in many of the engines they were in course of time bored out to 18¼in. and 18½in. diameter, all the engines, however, forty-seven in number, built until the end of 1893, had, when new, the standard 18in. cylinders.¹ The last six engines of 1894-95 were of increased dimensions, and will be referred to in due course.

Perhaps the most noticeable feature, apart from the 8ft. driving wheels, was the great simplicity of the design. To their excellent performances on the road, the writer refers later.

The Great Western design of 1873-75 by Joseph Armstrong was a further enlargement of Stephenson's double-framed 2-2-2 type. The first of these engines, built at Swindon in 1873, had a domed boiler. It was named "Queen," and was used for several years to haul the Royal trains—Fig. 242. The twenty subsequent engines of 1875 had domeless boilers, and the fire-boxes were stayed

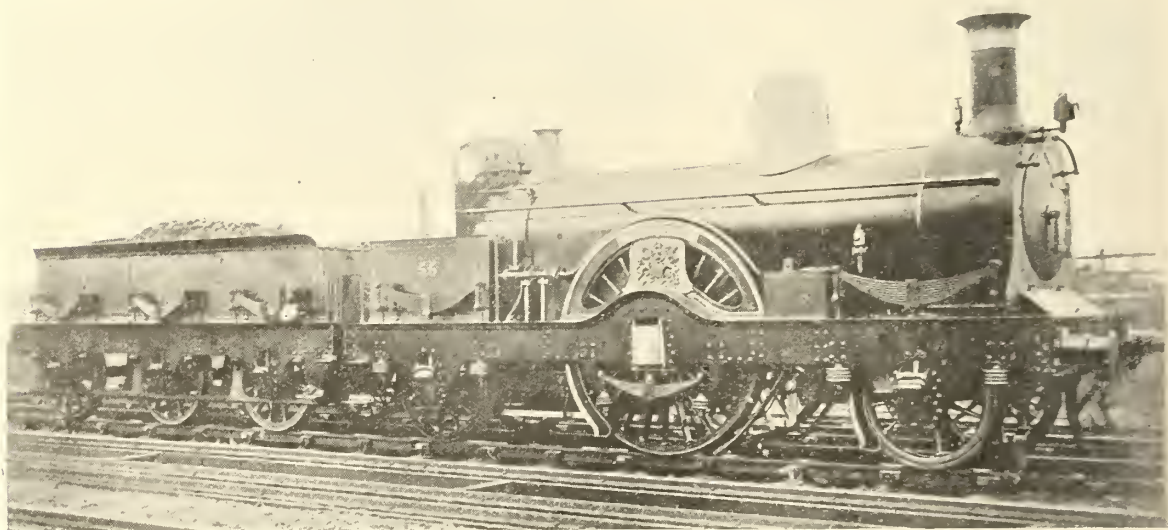

FIG. 242—J. ARMSTRONG'S EXPRESS LOCOMOTIVE, "QUEEN," G.W.R.L.V., 1873

was replaced by a built-up structure of plates and angle irons. The driving axles were strengthened, the diameter of the main bearings being increased from 8in. to 8½in., and helical springs were substituted for the plate springs of the first design, but the volute springs at the trailing end were replaced by plate springs. The boiler barrel was slightly enlarged, and 174 1¾in. tubes replaced the 217 1⁹/₁₆in. tubes originally used. The total heating surface was, however, decreased to 1045 square feet, of which the fire-box supplied 109 square feet. The pressure was raised to 160 lb. The weight in working order, considerably increased owing to the general strengthening of the detail parts, became:—On front bogie wheels, 8 tons 2 cwt.; hind bogie wheels, 9 tons 9 cwt.; driving wheels, 17 tons; trailing wheels, 10 tons 12 cwt.; total, 45 tons 3 cwt.

The cylinders, it may be noted, remained 18in.

directly to the casings. Following Sir Daniel Gooch's old practice, a transverse midfeather divided the grate into two portions, and there was also a water pocket across the top. Both ¾in. inside and ¾in. outside frames were of iron, and extended from front to back buffer beams.² The wheel base, 8ft. 6in. + 9ft. = 17ft. 6in., was exceptionally long, and resulted in a very steady engine at high speeds. The following were the leading dimensions:—Cylinders, 18in. by 24in. at 2ft. 6½in. centres; steam ports, 1ft. 4in. by 1¾in.; exhaust ports, 1ft. 4in. by 3½in.; driving wheels, 7ft.; carrying wheels, 4ft. diameter; the boiler, 4ft. 3in. diameter outside, was of 7/16in. Lowmoor plates, and contained 250 1½in. tubes,

¹ Drawings and a large plate illustration of these G.N.R. engines of the 1884-93 period appeared in *THE ENGINEER*, December 16th, 1892.

² For drawings see *THE ENGINEER*, September 22nd, 1876.

giving a heating surface of 1145.5 square feet; fire-box heating surface, 133 square feet, including the surfaces of water pocket and partition; total, 1278.5 square feet; grate, 18 square feet; pressure, 140 lb.; weight in working order, $33\frac{1}{2}$ tons, of which 14 tons rested on the driving wheels. The outside bearings of the driving axle were 6in. diameter by 9in. long, and the inside bearings 7in. diameter by 6in. long; carrying wheel bearings, in outside frames only, were 5in. diameter by 10in. long; the driving springs were underhung.

When these engines were rebuilt by Mr. Dean in 1884-87 with domed boilers, the steam ports were reduced to 1ft. 3in. by $1\frac{3}{4}$ in., and the exhaust ports enlarged to 4in. wide. The grate area was increased to $19\frac{1}{4}$ square feet by the omission of the midfeather. The weight was raised to 34 tons 12 cwt., of which $14\frac{1}{2}$ tons were carried on the drivers. These engines worked many of the fastest standard gauge expresses until the end of last century.

Stroudley's express engine—Fig. 243—of 1874

pressure, 150 lb.; total weight, 33 tons, of which 14 tons were carried on the driving wheels. Fig. 243 shows the engine at a later period of its existence, with an inside-framed tender of the 1880 design. As originally built, it had wooden brake blocks applied to the front of both driving and trailing wheels, actuated by both steam and hand brakes.

Between 1880 and 1882, twenty-four similar engines, but with smaller driving wheels—6ft. 6in.—were built at the Brighton works. They were used on the lighter Brighton expresses, and also worked nearly all the trains between London and Portsmouth.

Single v. Coupled Express Engines.—The appearance, followed by the great success, of Stirling's Great Northern 8ft. single engines brought into prominence the respective merits of single and four-coupled engines for express trains, and for many years an animated discussion on the subject took place. No locomotive engineer of that day would have employed a coupled express

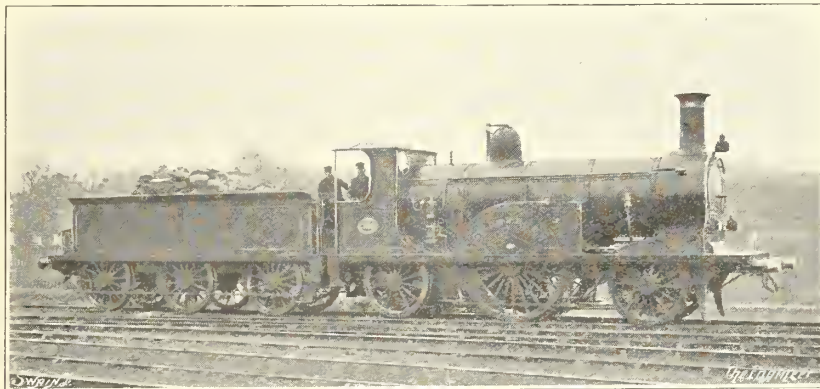

FIG. 243—STROUDLEY'S EXPRESS LOCOMOTIVE, L.B. & S.C. RLY., 1874

for the L.B. and S.C.R., with inside cylinders, had inside frames and bearings only, and in this respect followed the design of McConnell's "Bloomers." The dimensions form an interesting contrast to those of the G.W.R. engines dealt with above. The cylinders, 17in. by 24in., were placed at 2ft. 2in. centres, the difference being principally due to the necessity for long bearings for the driving axle in the inside frames. The ports were 1ft. 3in. long, the width of the steam ports being $1\frac{1}{2}$ in. and of the exhaust ports 2in. Driving wheels, 6ft. 9in.; carrying wheels, 4ft. 6in. diameter; wheel base, 8ft. + 7ft. 9in. The frames were 1in. thick; the driving axle bearings were 8in. diameter by 8in. long, and the carrying axle bearings 7in. diameter by $8\frac{3}{4}$ in. long. The driving springs were of the volute pattern. The slide bars were trough shaped, and the connecting-rods of circular section. The boiler had an external diameter of 4ft. 5in., and contained 206 $1\frac{3}{4}$ in. tubes, which provided 1022 square feet of heating surface. Total heating surface, 1132 square feet;

engine had he been convinced that a single engine was always reliable. P. Stirling, J. Armstrong, and others decided that the latter was equally reliable, and under the conditions of that day they were probably right. Certainly the Great Northern 8ft. singles took loads on express trains of greater weight and at faster speeds than those on any other railway, and they never, until the end of the century, took a pilot engine. In 1867-68 Mr. Stirling built both 2-2-2 and 2-4-0 engines for express work. The cylinders in both classes were 17in. by 24in., the boilers were of equal power, and the only difference of importance lay in that the single engines had 7ft. 1in. driving wheels, whereas those of the coupled engines were 6ft. $7\frac{1}{2}$ in. The coupled engines were therefore nominally more powerful when considered from the tractive force standpoint alone. Mr. Stirling himself stated that his experience of these two classes showed that with trains of equal weight the single engine was the better, and that even on the long uphill pull of $12\frac{3}{4}$ miles from King's Cross

to Potter's Bar, beginning with a 2 mile rise of 1 in 105, and the remainder mostly at 1 in 200, the single engine "had the best of it." Subsequently the same celebrated engineer expressed the matter tersely in saying that "a coupled engine was like a laddie running wi' his breeks doon."

The late Charles Rous-Marten, in a report dated 1887, based on train timings made during 1884-85, stated that with trains of 200 to 240 tons the 8ft. single engines never took more than $12\frac{1}{4}$ minutes for the 8 mile rise of 1 in 200 to Potter's Bar, even with the heaviest loads. He also compared the work done by these engines, the tractive force of which was 93.6 lb. per pound of effective pressure, with that of the coupled engines, with 6ft. 7in. driving wheels and $17\frac{1}{2}$ in. by 26in. cylinders, having a tractive force of 100.8 lb. per pound, and found that with equal loads of 15 six-wheeled coaches the former ascended the $15\frac{1}{4}$ mile bank, Tallington to Stoke signal-box, of which 8 miles rise at 1 in 200 and 1 in 178, in 21 minutes, as against $22\frac{1}{4}$ minutes taken by the coupled engine. In both cases the boiler pressure was 140 lb., but the heating surface of the 8ft. single engine was $5\frac{1}{4}$ per cent. and the cylinder volume, neglecting clearance, was $10\frac{3}{4}$ per cent. greater than that of the coupled engine.

When the Midland main line from Leicester to Hitchin was opened in 1858 and the trains of that company ran through to King's Cross, a few 2-4-0 express engines with 6ft. 6in. driving wheels were specially built for the service. These engines had what was not an uncommon defect in those days; they bent, and not infrequently threw, their coupling rods. They subsequently had to be converted to single engines. Similarly, Sturrock's 7ft. coupled express engines of 1866 had the same failing, and P. Stirling likewise rebuilt them as "singles." The causes are not far to seek. In 1858-61 both tires and rails were of iron, and the soft material wore unevenly, so that it was not very long before the coupled wheel tires had worn down unequally. The driving wheels were trying to drag the trailing wheels round faster than their normal rolling speed with the consequent stress on the coupling rods.

The writer also considers that in some cases defective balancing probably contributed to the cause of the trouble. Admitting that the revolving masses may have been correctly balanced, which in many cases is doubtful, it was usual to balance a very large proportion of the reciprocating masses. D. K. Clark, following Le Chatelier, gave rules, in which the whole of the reciprocating masses was balanced, though he recommended a distribution of this portion of the weight between the coupled wheels. At a later date, three-quarters of the reciprocating weight was balanced, but for some reason the whole of the balance weight corresponding to these masses was placed in the driving wheels alone instead of being distributed. The writer has records of engines which in 1875

were balanced in this way. Though it is true that the lighter and less massive engines of those days required the balancing of a larger proportion of the reciprocating masses than is necessary for heavy modern engines, nevertheless there was too great a variation of rail load, estimated as a percentage of the static weight on the driving wheels, which was then only about 11 to 13 tons. The result of this variation may be slight slipping through part of a revolution of the wheels, thus producing flats on the driving tires, and thereby throwing further stress on the coupling rods. Other things being equal, and within the limits of the adhesion available, the coupled engine gave a lower ratio of effective to indicated horse-power than the "single." In addition, there was the expense of and loss in re-turning the tires of two pairs of wheels to the diameter of the smallest wheel, a point of considerable importance owing to the comparatively rapid wear of the soft tires.

Amongst the very few successful coupled express locomotives of the 1860-66 period, J. Beattie's L. and S.W.R. engines, with 7ft. wheels, may be mentioned. The first three, built in 1859, had wrought iron tires, but in 1863 Beattie adopted steel tires and fitted them to these and the subsequent engines of 1864-68.

As tire material became harder, and the balancing was improved, the difference between the tractive efficiency of the two types of engine decreased, though it never disappeared. The writer knows of no exact test made in this country to ascertain the comparative resistance of single and four-coupled engines of equal power and similar dimensions. About 1887 Mr. James Holden, on the Great Eastern Railway, removed the coupling rods from a 2-4-0 express engine with 18in. by 24in. cylinders and 7ft. driving wheels, and worked it on express trains in that condition, with the result that he subsequently (1888-93) constructed a number of single engines of similar dimensions. Experiments made in Germany by F. Leitzmann by removing the coupling rods from a 4-4-0 compound express engine with 6ft. 6in. driving wheels, and allowing it to "coast" down a gradient of 1 in 200 without steam, showed that the coupling rods were responsible for 20 per cent. of the total frictional resistances of the engine. Starting from rest the coasting speeds attained, when acceleration ceased, were 24.8 miles per hour for the coupled, and 31.7 for the uncoupled engine. Leitzmann pointed out that the influence of coupling rods at higher speeds would be much greater owing to the increase in the dynamic forces produced. These experiments took place at about the end of last century, when tires were harder than was the case thirty years before, and it is very probable that the proportion of frictional resistance due to coupling rods was at one time greater than 20 per cent.

Apart from the G.N.R., G.W.R., and L.B.S.C.R., many other main lines, such as the

Great Eastern, South-Eastern, Caledonian, etc., used single engines almost exclusively for their best expresses, and on the London and North-Western south of Crewe the majority of trains were worked by them until about 1878-80. The Midland, which had heavier gradients, used coupled engines exclusively on the main line expresses, and built no singles from the early part of 1866 to the latter part of 1887. The booked speeds of the fastest trains on that line between Bedford and Leicester from 1866 to 1874 were 45 to $45\frac{3}{4}$ miles per hour. On the North-Eastern the East Coast Scotch expresses were worked between York and Edinburgh by coupled engines, though the gradients for the greater part of the road are comparatively easy. These were the same trains which were hauled between London and York by the Great Northern single engines at higher speeds over a considerably heavier road.

There was no steam sanding apparatus until 1886; the lack of adhesion, when starting trains

the ordinary, other than that the outside plate frames allowed extra bearing area for the driving axle, and that the cylinder centres were spread out to 2ft. 6in. instead of the usual 2ft. 4in. or thereabouts, for inside-framed engines, their excellent work decided S. W. Johnson in 1875-76 to use them for the heaviest Scotch and other expresses between London and Carlisle, and to this end he provided them with new 18in. by 24in. cylinders (eleven engines 18in. by 26in.) and larger boilers. The latter contained 223 $1\frac{3}{4}$ in. brass tubes, of which the heating surface was 1115 square feet; total heating surface, 1225 square feet; grate area, $17\frac{1}{2}$ square feet. The original weight of 36 tons 3 cwt. in working order was increased to about 40 $\frac{1}{2}$ tons. The original frames and motion were retained. The thickness of the outside frames was $1\frac{1}{8}$ in., and of the inside frames $\frac{3}{4}$ in. Some of these frames are still in service. Fig. 245 shows No. 815, one of the class as rebuilt. Incidentally, this was the engine which ran from Carlisle to Aisgill summit, 48 $\frac{1}{4}$ miles, in 59 min.

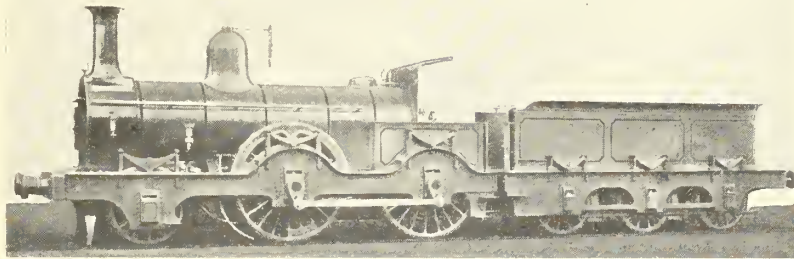

FIG. 244—M. KIRTLEY'S EXPRESS ENGINE, MIDLAND RLY., BUILT BY NEILSON & CO., 1870

of 150 tons and over in slippery weather, made itself felt after 1880, and in the winter months of the 1880-86 period the singles were sometimes unreliable. The steam sand blast subsequently gave the type a new lease of life, as will be mentioned later. But by that time the rails had become heavier and the road generally improved so that considerably more weight could be allowed on the driving wheels.

Coupled Express Engines, 2-4-0 Type.—Space permits of the mention of only certain of the more prominent engines which either had excellent reputations or possessed certain features to which attention may usefully be directed. In the front rank were M. Kirtley's celebrated Midland engines, 800 class, with 6ft. 8in. coupled wheels and outside bearings throughout. There were forty-eight of the class, eighteen built at Derby in 1870-71, and thirty by Neilson in 1870. As originally constructed with 17in. by 24in. cylinders, 1097 square feet of heating surface and 140 lb. pressure, they are shown in Fig. 244. Although their dimensions were in no way out of

with a load of 130 tons, a total rise of 1100ft., the last 11 miles at 1 in 100.

There was one valuable characteristic of all the rebuilt engines of the 800 class; they would stand a great deal of what the drivers used to term "hard thumping," *i.e.*, they could be worked for considerable distances with heavy trains with the lever well down and a late cut-off, without running themselves "out of breath." There were on the same railway other excellent engines with the same boiler and general dimensions—also rebuilt with 18in. by 24in. cylinders—but with the difference that the driving bearings were inside and the cylinder centres 2ft. 4in. apart. The latter engines had an offset of $1\frac{1}{4}$ in. in the valve spindles, as compared with only $\frac{1}{2}$ in. in the 800 class. The steam chest space of the 800 class was wider than that of the inside-framed engines. The writer does not definitely know the port areas of the 18in. cylinders of the rebuilt engines, but at that time (1876-82) S. W. Johnson's standard 18in. cylinders had ports $15\frac{1}{2}$ in. by $1\frac{3}{8}$ in. and $3\frac{1}{2}$ in. Further, no indicator diagrams exist, and in the absence of

them it is impossible to give definite reasons for the special qualities shown by the two types. The rebuilt inside-framed engines, also with 18in. by 24in. cylinders, though they did excellent work, could certainly not stand the continuous "hard

4ft. 2in. leading and 6ft. 8½in. coupled; wheel base, 8ft. + 8ft. 6in., which was standard for all Midland six-wheeled engines from 1860 onwards, other than those of the 2-2-2 type. The leading axles of both these and of the previous 800 class

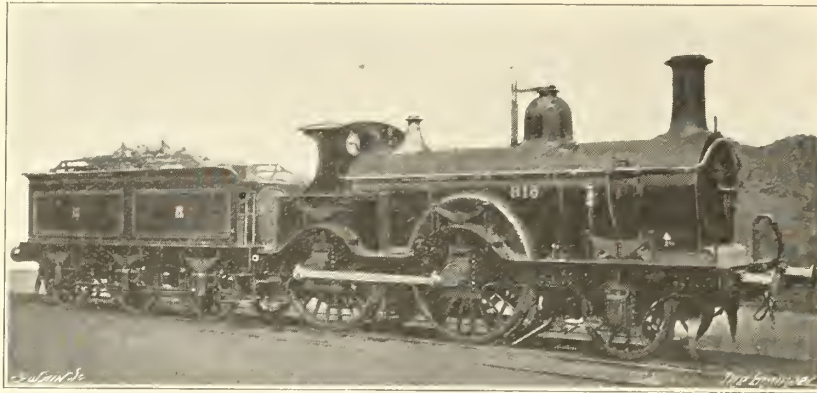

FIG. 245—M. KIRTLEY'S 800 CLASS EXPRESS LOCOMOTIVE, MIDLAND RLY., AS REBUILT 1875-82

thumping" which the 800 class seemed to bear with comparative ease. It is tentatively suggested that the larger steam space in the valve chest, which in both classes was placed vertically between the cylinders, may have had a great influence. The motion being of similar dimensions, there would be no reason for a different valve setting.

The second type of Midland express engine, the 890 class, which had inside bearings for the coupled axles—Fig. 246—is that which, in its subsequent rebuilt state, has been referred to

had outside bearings, the axle-boxes having ½in. lateral play in the horns on each side of the centre line, but without any controlling arrangement, such as inclined planes. This simple method of providing flexibility was characteristic of most of the company's 2-4-0 engines of this type, and was successfully used until 1881. The springs of the coupled wheels were connected by compensating levers, but these were removed about 1875-76. The boilers, 4ft. 1in. diameter inside, contained 232 1½in. tubes, which provided 1028 square feet of heating surface; total heating surface, 1122 square

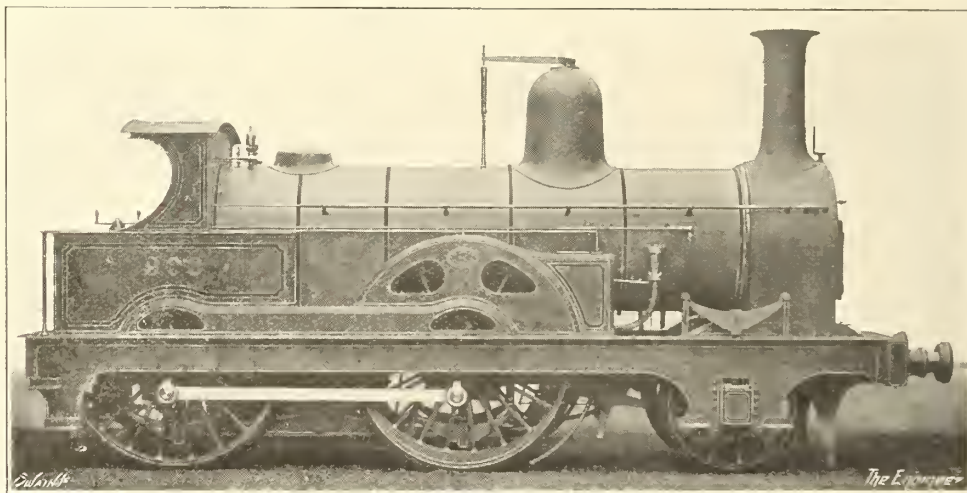

FIG. 246—M. KIRTLEY'S 890 CLASS EXPRESS LOCOMOTIVE, MIDLAND RAILWAY, 1871

above. Of these engines the first twenty by Neilson, 1871, were the prototypes of the numerous 2-4-0's still at work on the line, and were the first Midland engines to be provided with cabs. The cylinders were 17in. by 24in.; wheels,

feet; pressure, 140 lb.; grate area, 16 square feet; weight in working order, 11 tons 0 cwt. 3 qr.; driving, 12 tons 17 cwt.; trailing, 12 tons 14 cwt. 3 qr.; total, 36 tons 12 cwt. 2 qr.

Thirty-six similar engines were built at Derby,

1872-74, with the only difference in dimensions that the boilers had 188 2in. tubes, which gave practically the same amount of heating surface. The question of tube diameter, to which much attention was devoted between 1870 and 1880, is referred to subsequently.

It may be of interest to add that when the Midland Railway introduced Pullman cars into this country in 1874 the complete Pullman trains were worked between Leeds and St. Pancras by the 890 class, as illustrated. For this purpose the tenders were fitted with central buffers of the American pattern. Two years later, when the complete trains were split up and the coaches used in the ordinary Scotch and other expresses, they were provided with British side buffers, and the central buffers were removed.

Another successful series of very similar coupled express engines was the 901 class of the North-Eastern Railway, designed by E. Fletcher. These engines, which worked all the East Coast Scotch express trains between York, Newcastle and Edinburgh, first appeared in 1872, and fifty-five of them were built between then and 1882, thirty-five at Gateshead works, ten by Beyer, Peacock, and ten by Neilson. One of the Neilson engines is shown in Fig. 247. The cylinders of those built

so arranged that the nut engaging with the screw could be lifted out of gear when quick reversing was necessary. The ports were 15in. by $1\frac{1}{8}$ in. and $3\frac{1}{2}$ in., and the valves had $1\frac{1}{4}$ in. outside lap, and $\frac{1}{16}$ in. inside lap; maximum travel about $4\frac{1}{2}$ in. For 2-4-0 engines of the period they were heavier than usual, partly on account of the large boilers and partly owing to the inside frames, which were $1\frac{1}{4}$ in. thick. The first engines, built before the adoption of a continuous brake, had wood brake blocks on the coupled wheels actuated by hand. In this respect they were amongst the earliest examples of express tender engines with engine brake power.

Stroudley's first coupled engines of 1872-75 for the Brighton Railway—Fig. 248—differed completely from the later types with which his name has generally been associated. The former had double frames and the driving was coupled to the trailing, instead of to the leading axle. The outside springs of the coupled wheels were underhung. The dimensions may be compared with those of the engines described above. Cylinders, 17in. by 24in., placed with centres 2ft. 6in. apart as in the double-framed Midland engines; leading wheels, 4ft. 1in.; coupled wheels, 6ft. 6in. diameter; wheel base, 8ft. 4in. + 8ft. 4in.; the

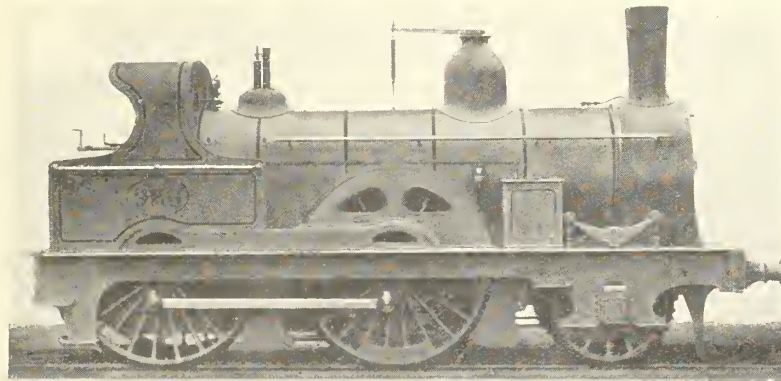

FIG. 247—E. FLETCHER'S FOUR-COUPLED EXPRESS ENGINE, NORTH-EASTERN RLY., 901 CLASS, 1872

in 1872-76 were 17in. by 24in., placed at 2ft. $4\frac{1}{2}$ in. centres. The later engines of 1880-82 had $17\frac{1}{2}$ in. by 24in. cylinders. The coupled wheels were 7ft. and the leading wheels 4ft. 6in. diameter; wheel base, 8ft. 4in. + 7ft. 9in. The boiler, with 254 $1\frac{9}{16}$ in. tubes, had a total heating surface of 1208 square feet, of which the fire-box provided 98.5 square feet; grate area, 16.1 square feet; pressure, 140 lb.; weight in working order: leading, 12 tons 8 cwt.; driving, 14 tons 3 cwt.; trailing, 12 tons 18 cwt. The leading axle-boxes had some lateral play in the horns, as in the Midland engines, and to diminish the tendency to cant and cause uneven wear owing to non-central spring pressure, the leading journals were 1ft. long. The tires had a width of 6in. The reversing gear was of the combined lever and screw type, the lever being on the outside of the screw with the usual trigger,

total heating surface varied from 1234 square feet in the first engines with 260 $1\frac{1}{2}$ in. tubes, to 1123 square feet in the later engines with 206 $1\frac{3}{4}$ in. tubes. Owing to boiler differences, the total weight of the first engines was 41 tons 4 cwt., of which 15 tons rested on the driving and 13 tons 4 cwt. on the trailing wheels, but the later engines had a total weight of 39 tons 3 cwt., the load on the trailing wheels being 11 tons 1 cwt. The former were the heaviest 2-4-0 engines of their day, the load on the driving wheels being exceptional. The outside cranks had a shorter throw than the inside cranks, and were placed on the same side of the axle, both features being in accordance with Stroudley's usual practice. Until 1880-81, these engines worked the heavy "business" expresses between Brighton and London Bridge.

F. W. Webb's 2-4-0 express engines on the London and North-Western Railway were a complete contrast in nearly all respects to the types described previously. The "Crewe" engines of 1874 to 1882, until the appearance of the three-

The "Precedent" class—Fig. 250—which came out in December, 1874, was originally intended only for the heavier trains on the southern division between Crewe and Euston, a line which has comparatively easy gradients, though the trains

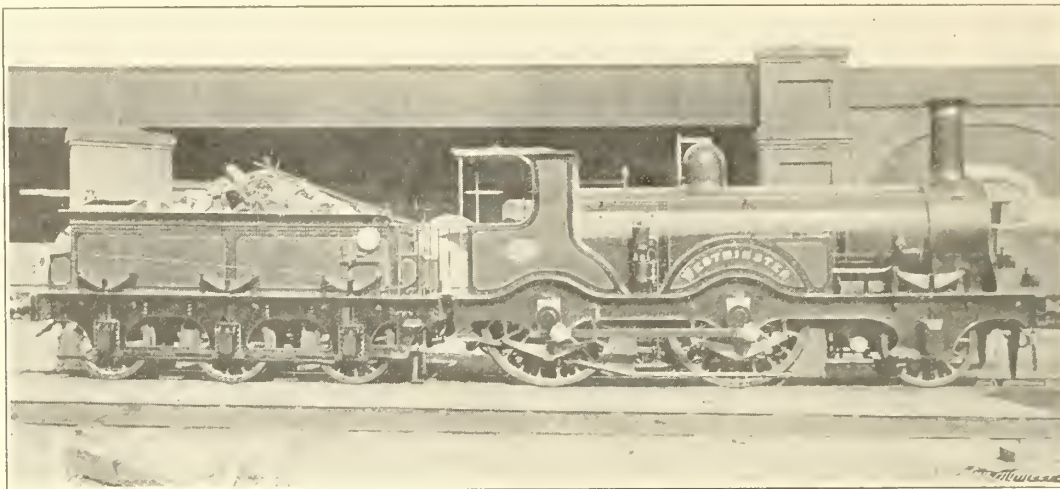

FIG. 248—STROUDLEY'S EXPRESS LOCOMOTIVE, L.B. & S.C. RLY., 1872-75 [Photo. Locomotive

cylinder compound engines, were small and light. Low cost seems to have been the main principle aimed at in designing an engine with a maximum of tractive force for a minimum weight, an excellent principle provided that the tractive power is real and not nominal. The two classes of engine described below provide a very interesting study of the effect of locomotive proportions.

The first of these, the "Precursor" class³—Fig. 249—appeared in April, 1874, and for the purpose of working over the Crewe-Carlisle section, on parts of which the gradients are heavy, had coupled wheels only 5ft. 6in. diameter.

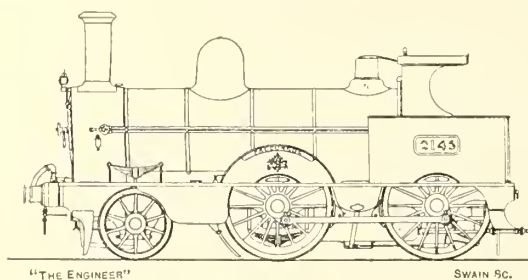

FIG. 249—WEBB'S "PRECURSOR," L. & N.W.R., 1874

Before deciding upon this dimension, Mr. Webb for a time tried a six-coupled goods engine with 5ft. 6in. wheels on fast trains, by removing the coupling rods between the leading and driving wheels, with apparently satisfactory results.

³ These engines must not be confused with the present "Precursor" class, designed by Mr. Whale in 1904. Unfortunately both classes were always known by the name of the first engine of each.

were heavier. Apart from the size of the coupled wheels, 6ft. 7½in., in the case of the "Precedents," the only other differences of moment between the two classes were that the latter had somewhat larger fire-boxes, giving 103 square feet of heating surface, as compared with 94.6 square feet of the "Precursors," the boiler of the "Precedent" was pitched with its centre further from the rails, and the latter engines weighed 27 cwt. more.

The following dimensions and particulars were common to both classes:—Cylinders, 17in. by 24in.; ports, 14in. by 1½in. and 3¼in.; centres of cylinders, 2ft., a dimension which enabled long

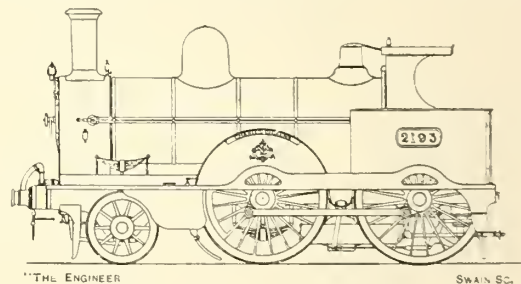

FIG. 250—WEBB'S "PRECEDENT," L. & N.W.R., 1874

bearings to be given to the crank axle, and which was attained by making the steam chest of ▽ form. The cylinders were horizontal, but the port faces were inclined laterally and also longitudinally to suit the inclination of the valve spindles, an arrangement which allowed plenty of space in the steam chest. The leading wheels were only 3ft. 7½in. diameter, the axle-boxes having ¼in. lateral play, controlled by inclined

planes. These axle-boxes were of gun-metal, but those of the coupled wheels were of cast iron and of the American pattern with crescent-shaped brasses forced into place. All hornblocks were of cast iron. Main frames, $\frac{7}{8}$ in. thick; bearings of coupled axles, 7in. diameter by 9in. long; wheel base, 7ft. 5in. + 8ft. 3in. = 15ft. 8in. Allan's straight link valve motion was used.

The boiler, in three rings, had a diameter of 4ft. 0 $\frac{1}{2}$ in. inside the front ring and 4ft. 2in. inside the back ring, and contained 198 1 $\frac{7}{8}$ in. tubes, the heating surface of which was 980 square feet. Total heating surface of "Precursor," 1074.6 square feet, and of "Precedent" 1083 square feet; grate area, 17.1 square feet, and pressure 140 lb. in both engines. The fire-box of the "Precursor," as built, had a longitudinal narrow brick arch which extended from the main arch to the back plate, and acted as a deflector. This was afterwards abandoned. The fire-hole rings were of gun-metal protected internally by a steel lining. The regulator was in the smoke-box, and resembled a rotating Corliss valve. Subsequently, Mr. Webb discarded this regulator and returned to Ramsbottom's double-beat type placed in the dome.

A feature common to all the L. and N.W.R. engines was an ash hopper beneath the smoke-box, into which the ashes descended through spaces at the sides of the cylinders. The hopper tapered to an opening at the bottom, 5 $\frac{1}{2}$ in. by 1 $\frac{1}{2}$ in., and to prevent the air from rushing up it the back plate was made shorter than the front plate. It was stated that this apparatus did not seriously affect the draught of the engine, and since it was used for many years, no great trouble seems to have arisen from it.

The blast orifice of the "Precursor" was originally 4 $\frac{3}{4}$ in., but the writer is under the impression that it was subsequently reduced to that of the "Precedent," *viz.*, 4 $\frac{1}{2}$ in. diameter.

Another slight difference in detail between the two engines may be noted. The "Precursor," having small driving wheels, was made with the half-throws of the coupling rods 10in. only. In this respect Webb copied Stroudley's practice, but the latter used the short throw for 6ft. 6in. coupled engines also, whereas in Webb's 6ft. 7 $\frac{1}{2}$ in. "Precedents" the throw was longer, though whether it was 11in. or 12in., the writer is uncertain. A peculiarity of an extremely dubious nature in the "Precursor" was that, although there were balance weights in the rims of the driving wheels, there were none in the trailing wheels, and presumably the revolving masses in the latter were unbalanced. The official weights in working order were:—

	"Precursor."		"Precedent."	
	t.	c.	t.	c.
Leading	10	5
Driving	10	10
Trailing	10	0
	31	8	32	15

These weights may be compared with the 36 $\frac{3}{4}$ to 39 $\frac{1}{4}$ tons weight of the corresponding Midland and North-Eastern engines of that day, with 17in. by 24in. cylinders. The difference lay chiefly in the boilers and frames. As regards boilers, those of the L. and N.W.R. engines appear too small for heavy main line express work. They may have been just large enough for the work required in 1874-76, but subsequently they had to be forced at the cost of heavy fuel consumption. In 1874 the Midland increased the sizes of the boilers and fire-boxes for 17in. by 24in. cylinders, making the heating surface 1225 square feet, instead of about 1120 square feet, and that of the N.E.R. and G.W.R. engines also exceeded 1200 square feet. The maximum cut-off in full gear in both "Precursors" and "Precedents" was then only about 63 $\frac{1}{2}$ per cent. of the stroke, as compared with 70 to 72 per cent. then usual on other railways.

On the other hand, there were several good features in the design, notably the long bearings, ample-sized crank webs, and the large ports. The area of each of the steam ports, 21 square inches, was .0925 of the piston area, and the undoubtedly excellent speeds which the "Precedents" frequently attained was probably due to the ease with which the exhaust steam left the cylinders.

These engines have been described at some length for reasons which will appear below. Of the "Precedents" it may be said that they were the mainstay of the L. and N.W.R. express services for about thirty years. The three-cylinder compounds succeeded them between 1883 and 1898, but the latter were not always reliable, and whenever any steady hard main line work had to be done in emergencies the "Precedents," undersized though they were, had to do it somehow, though their coal bill was high. After 1887 the pressure of the "Precedents" was raised to 150 lb. when new boilers were provided.

To appreciate the results given by the "Precursors," which have considerable interest, a few particulars of gradients and train speeds are necessary. The engines worked through between Crewe and Carlisle (141 $\frac{1}{4}$ miles) on some turns; on others between Preston and Carlisle (90 miles), or Preston and Crewe (51 $\frac{1}{4}$ miles). From Crewe to Preston and thence to a point about 34 miles north of the latter station the gradients are generally easy, and the two or three short sharp rises of 1 in 100 to 1 in 132, each about one mile long, can be "rushed" by a train running at speed. The heavy work then begins with the 13-mile ascent, averaging 1 in 125 to Grayrigg, the last two miles being at 1 in 100. From Grayrigg there is a fall of about 5 miles to near Tebay, giving a fast train the opportunity of running at the Shap bank, which starts with 2 miles of 1 in 147, followed by 4 miles of 1 in 75. The last 31 miles to Carlisle from the summit are downhill, the steepest gradients being at 1 in 125

($6\frac{1}{2}$ miles) and 1 in 132 (3 miles). Summing up, of the $141\frac{1}{4}$ miles there are only about 20 miles on the down journey of really hard uphill gradients, the rest of the road being comparatively level or downhill. On the up journey from Carlisle the work is harder with about 33 miles of "collar work," of which nearly all has to be done in the first 31 miles from the dead start at Carlisle.

The fastest train was the 10 a.m. Scotch express from London, which was booked at a speed of about 46 miles per hour from Crewe to the first stop at Preston. From Preston to Carlisle the time allowed was 2 h. 10 min., a speed of $41\frac{1}{2}$ m.p.h. The night Scotch express ran from Crewe to Wigan, $36\frac{1}{4}$ miles, at the rate of 45 m.p.h.; Wigan to Preston, 15 miles, at 42.8 m.p.h.; Preston to Carnforth, $27\frac{1}{2}$ miles, at 42 m.p.h.; and from Carnforth to Carlisle, $62\frac{1}{2}$ miles, at just over 40 m.p.h. There were corresponding up trains, and a number of additional expresses at slightly slower speeds. The loads of the trains varied from eleven to fifteen six-wheeled coaches, the fastest trains having about eleven or twelve. If their weight be taken at about 11 tons each, an approximate idea of the total weights may be obtained. Trains of eleven, or occasionally twelve, coaches ascended the Shap bank unaided, as they were helped by the preceding downhill run. With greater loads a pilot engine was taken, usually in the form of a bank engine at the rear from Tebay, where a special stop was made for the purpose. From Carlisle to Shap summit on the up journey pilot engines were very frequently used.

The "Precursors" were specially built with small driving wheels to negotiate these gradients, and there is no doubt that with a tractive force of 105.1 lb. per pound of mean pressure they climbed the hills better than Ramsbottom's 6ft. 6in. coupled engines which preceded them, but the latter had only 120 lb. boiler pressure, as against 140 lb. of the "Precursors." But after about three to four years' work the "Precursors" had to be taken off the fastest trains, on which they were replaced by the 6ft. $7\frac{1}{2}$ in. coupled "Precedents." For some years longer the "Precursors" worked the slow and semi-fast trains only, and for about twenty years they also worked the slower trains between Manchester and Leeds, a road with heavy gradients. They failed in working the fast trains over the Carlisle road owing to the higher speeds which were necessary on the easy portions between Crewe and Carnforth and the downhill running on both sides of the Shap summit. Their hill-climbing ability, tempered though it was by the small size of their boilers, could be utilised only over a comparatively short portion of the total mileage, and for the remainder of the journey the driving wheels were too small for economical and satisfactory work.

The principal dimensions of these engines may

be compared with the "Schenectady" engine, with which Dr. Goss conducted his experiments at Purdue, U.S.A. The cylinders, 17in. by 24in., and the boiler pressure, 140 lb., were the same in both cases. The steam port area of the "Precursor" was slightly larger, in the ratio of 21 to 20, but the "Schenectady" engine had a larger boiler. The driving wheels of the latter were 5ft. 3in., *i.e.*, 3in. smaller. Dr. Goss found that the "critical speed," *i.e.*, the speed at which the power and efficiency of a locomotive are a maximum, was not far from 200 revolutions per minute, corresponding to a piston speed of 800ft. per minute, for 24in. stroke. Professor Dalby ("Proc.," Inst. C.E., 1906) worked out one series of Goss's experiments, and found that with a cut-off of 25 per cent. and boiler pressure 130 lb. it showed a maximum indicated horse-power piston speed of 887ft. per minute with a mean pressure in the cylinders of 27.5 lb. per square inch. The data for the "Precursor" can only be assumed approximately, but it will probably not be far from the mark if we take the maximum horse-power piston speed to be 880ft. per minute, and for 140 lb. boiler pressure and 25 per cent. cut-off, the M.E.P. works out at about 32.5 lb. per square inch, using Professor Dalby's method. This corresponds to a speed of 43.2 miles per hour for the "Precursor," as that at which the maximum indicated horse-power, about 393, was obtained. As the trains were timed so that long distances had to be run at speeds of 50 to 60 miles per hour in order to keep time, it is apparent why the "Precursors" were not satisfactory, though it must not be forgotten that the knowledge derived from Goss's experiments was not available when the engines were designed. At 55 miles per hour the "Precursor" would develop about 362 indicated horse-power with a M.E.P. of 23.5 lb., and at 60 miles per hour the indicated horse-power would drop to about 336, supposing the cut-off to remain unchanged at 25 per cent. and the boiler could supply the steam.

The cylinders and ports of the "Precedent" class with larger—6ft. $7\frac{1}{2}$ in.—wheels were exactly similar to those of the "Precursor," and if similar valve setting also be assumed, it seems reasonable to take it that the maximum high-pressure piston speed at 25 per cent. cut-off may also be taken at 880ft. per minute. This corresponds to 51.6 miles per hour. Using the same mean pressure line, the indicated horse-power curves show that up to about 46 to 47 miles per hour the "Precursor" developed a greater indicated horse-power than the "Precedent," but beyond that speed the "Precedent" was the more powerful engine, although its tractive force per pound of mean effective pressure was only 87.8 lb., as against 105.1 lb. for the "Precursor." The above figures take no account of the internal frictional resistances of the engines. At equal speeds in miles per hour the "Precursor" would lose more power in friction

that the "Precedent" owing to the higher piston speed. The result, though paradoxical, is borne out by the performances of the two classes of engine. The factor of adhesion of the two engines was in the ratio of 1.25 to 1 in favour of the "Precedent." When new the "Precursor" was said to have developed 529 and 531 indicated horse-power at 49 and 58 miles per hour, the respective piston speeds being 998½ ft. and 1181½ ft. per minute. The boiler pressures were 126 lb. and 123 lb., and the mean effective pressures 38.6 lb. and 32.7 lb. respectively.⁴ Had the engines been able to produce these results consistently and economically, they would hardly have had to be taken off the expresses and replaced by the "Precedent" class.

Brief mention may be made of the "Charles Dickens," the most celebrated of the "Precedent" class. Built in February, 1882, it ran daily from Manchester to Euston and back, and in 1902 was stated to have completed 2 million miles on this service, after which it was relegated to lighter work. As it was broken up in 1912 the total

wheels, 6ft. 0½ in., and of leading wheels of No. 1068, 4ft. 0½ in., though later and very similar engines of 1876 had 4ft. 8½ in. leading wheels. Wheel base, 8ft. 6in. + 8ft. The boiler, 4ft. diameter, had 158 2in. tubes, and a total heating surface of 1100 square feet; pressure, 140 lb.; the total weight was 31 tons 8 cwt. in working order, of which 20 tons 8 cwt. rested on the coupled wheels. Very similar engines, but with 6ft. 6in. coupled wheels, were built at Darlington in 1877.

4-4-0 *Express Engines*.—From 1871 onwards there was a gradual development of the 4-4-0 engine on British railways, chiefly in Scotland. The first two 4-4-0 engines of what is now the standard British type, *i.e.*, with inside cylinders and inside frames, were built by the North British Railway at Cowlaers Works in 1871 to the designs of Thomas Wheatley—Fig. 252. They had 17in. by 24in. cylinders and 6ft. 6in. coupled wheels. The bogie wheels, 2ft. 9in. diameter, had solid centres; coupled wheel base, 7ft. 7in.; bogie base, 6ft.; weight in working order, 37 tons 1 cwt., of which 13 tons 17 cwt. rested on the bogie wheels.

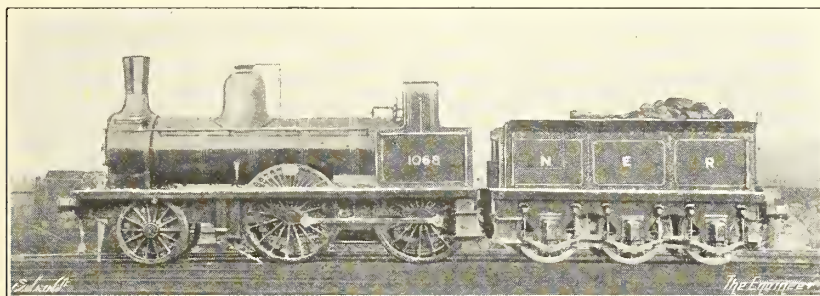

FIG. 251—N.E.R. (S. AND D. SECTION) LOCOMOTIVE, 1875-76

mileage must have been about 2¼ millions. It would be interesting to learn how much of the original engine remained in it at the termination of its career. The other "Precedents" of 1874-82 had been practically completely renewed, and very little, if anything, of the original engines remained. The crucial question is whether the original frames of the "Charles Dickens" lasted throughout, bearing in mind that they were only ¾ in. thick. Much may be done with a knife, if it be provided with three or four new blades, and a similar number of new handles.

The 2-4-0 engine—Fig. 251—built at the North Road engine works, Darlington, in 1875, is of considerable interest in that it represents the last type of passenger engine of "Stockton and Darlington" design. It was due to Mr. John Kitching, then in charge of Darlington works. The engine, No. 1068, of the N.E.R., was shown at the Darlington Jubilee of 1875. All the springs of both engine and tender were underhung. The cylinders were 17in. by 26in.; diameter of coupled

Four similar engines, with larger 3ft. 4in. bogie wheels also with solid centres, and with boilers having domes on the middle of the barrel, were built in 1873, and were employed on the Edinburgh-Carlisle service. The first of the two 1871 engines, No. 224, was the one which went down with the Tay Bridge in the disaster of December, 1879. It was subsequently recovered, only slightly damaged, and put to work again, remaining in service until 1919.

The 4-4-0 engine, with *inside* cylinders, defined above as the British type, had been previously built in America.

The much larger and more modern engines designed by James Stirling for the Glasgow and South-Western Railway—shown in Fig. 253—presented several features of interest. The cylinders, 18in. by 26in., at 2ft. 4½ in. centres, had large ports 16in. by 1½ in. and 3in.; diameter of coupled wheels, 7ft. 1in.; of bogie wheels, 3ft. 7in.; total wheel base, 20ft. 3¾ in.; coupled wheel base, 8ft. 3in. The bogie of the rigid centre pin type was peculiar in that the wheel base, 4ft. 10in., was extremely short, and the pivot was

⁴ The indicator diagrams and drawings of the "Precursor" class appeared in *ENGINEERING*, March 5th, 1875.

not central. Unlike his brother, Patrick Stirling, who in his 8ft. single engines placed the pivot behind the centre line, James Stirling placed it 1in. in front, dividing the base into 2ft. 4in. + 2ft. 6in. P. Stirling gave definite reasons for his arrangement, but it is not known that James Stirling ever announced his reason for adopting the opposite

The boilers of the G. and S.W.R. 4-4-0 engines contained 252 $1\frac{1}{2}$ in. tubes, which gave a heating surface of 1027.6 square feet. The total heating surface was 1111.8 square feet, and the grate area 16 square feet; pressure, 140 lb.; weight of engine in working order, 39 tons, of which the bogie carried 12 tons 12 cwt.

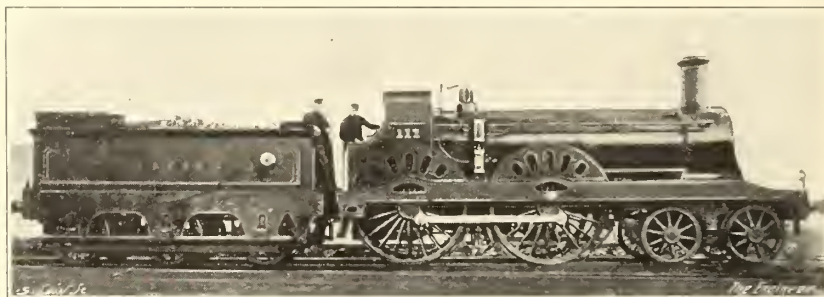

FIG. 252—T. WHEALLEY'S EXPRESS ENGINE, NORTH BRITISH RAILWAY, 1871

course. To damp lateral rocking on the bogie, two brackets were fixed on the frames, one on each side, with corresponding brackets on the main frames, and rubber washers between them. The main frames were $1\frac{1}{4}$ in. thick.

The boiler was of the domeless type with perforated steam pipe, the regulator being placed in the smoke-box. The arched crown on the fire-box was stayed directly to the casing. The injector feed entered the boiler at the middle of the back plate of the casing underneath the firehole. J. Stirling at that time stated that no harm had resulted from this method, whereas when the water was delivered at the sides of the fire-box, injury to the latter occurred. The latter method was that

The first of these engines came out in July, 1873, from Kilmarnock works, and had lever reversing gear, but the succeeding 21 engines of 1874-77 were provided with steam reversing gear. This gear with steam and cataract cylinders placed horizontally on the driver's side in the cab is so well known that detailed description is unnecessary. It was the parent of nearly all modern forms of steam reversing gear. Its one disadvantage was that the engine could not be reversed at the running shed when not in steam. When putting the engine away at the shed it was left by the driver in mid-gear with the handles locked. The weigh-bar shaft was balanced by means of a coiled spring.



[Photo. Locomotive]

FIG. 253—J. STIRLING'S G. & S.W.R.LY. LOCOMOTIVE, 1873-77

used by P. Stirling in the early Great Northern 8ft. singles, though it was subsequently discarded for the usual method of feeding into the sides of the boiler barrel. J. Stirling in later years abandoned the feed inlet at the back of the fire-box for one through the smoke-box tube-plate.

P. Stirling on the G.N.R. never adopted his brother's reversing gear, but stuck faithfully to the old lever and notched quadrant until his death in 1895. Although they were in agreement as regards boiler design, the brothers differed materially in their types of express engine. P.

Stirling never built a 4-4-0 engine of any class: after 1873 J. Stirling never constructed any other type for main line passenger service.

In 1874 two 4-4-0 engines with inside cylinders 17in. by 24in. and four-coupled wheels 6ft. 7in.

of express trains, though it should be added that from 1875 to 1878 these engines worked one fast train in each direction between Saltburn and Leeds. The type was derived from the four Stephenson's 4-4-0 engines of 1862 previously

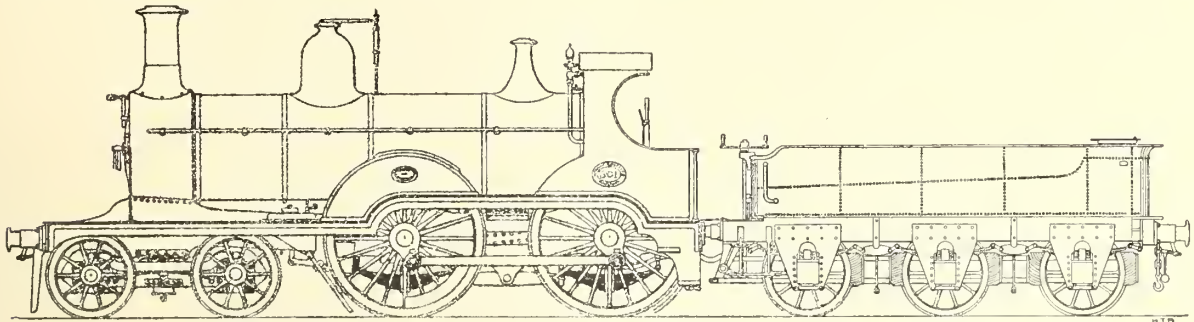

FIG. 254—S. W. JOHNSON'S ENGINE FOR THE GREAT EASTERN RAILWAY, 1874

This illustration shows a standard Sinclair tender, none having been built specially for these engines.

diameter were completed at Stratford Works for the Great Eastern Railway, to designs prepared by S. W. Johnson before he left that railway for the Midland—Fig. 254. The drawings were made in 1872-73, and were contemporaneous with those of J. Stirling's engines. They were the first 4-4-0 engines with inside cylinders and inside frames to be placed in service on any *English* railway. The bogies, which had 3ft. 7in. wheels and a base of 6ft., were of Adams's sliding type. The total heating surface was 1210½ square feet, and the pressure 140 lb. An interesting detail was that the fire-boxes were of iron, but after about two years' service were replaced by copper boxes.

Of the 4-4-0 type with outside cylinders, ten remarkable engines—Fig. 255—were designed by W. Bouch and built at the Darlington works of the Stockton and Darlington section of the N.E.R. Although they had wheels 7ft. diameter,

described—Fig. 187 *ante*—but differed from the latter in several important details. The cylinders were 17in. diameter, with the extremely long stroke of 30in., and until the Great Western adopted a stroke of this length thirty years afterwards these were the only examples of the sort. The piston valves were solid brass discs 13in. diameter, and their expansion in the steam chests, which were without liners, caused no end of trouble. Additional inconvenience resulted owing to the absence of any collapsible rings to allow the escape of water trapped in the cylinders. The bogie, which had 3ft. 7in. wheels and a wheel base of 6ft. 6in., was of a somewhat retrograde design, with a large ball which dropped into a deep socket, but unlike D. Gooch's bogie of 1849 or that of Stephenson's previous engines of 1862 for the S. and D.R., which had a pin extension of the ball, secured by a nut below, Bouch's pivot had no such

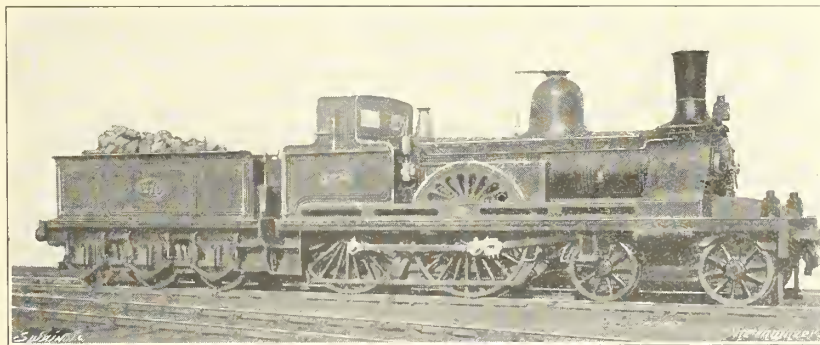

[Photo. Locomotive

FIG. 255—W. BOUCH'S N.E.R. (S. AND D. SECTION) LOCOMOTIVE, 1872-74

they were not express engines as ordinarily understood, since the S. and D. main line between Saltburn, Darlington, and thence to Tebay over the steep gradients of the Yorkshire and Westmoreland hills, did not boast of anything in the nature

extension, but only a thin plate at the top, which fitted round a recess machined round the top stem of the ball. This stem was tapered upwards and was secured to the bottom plate of the smoke-box by means of a nut. Altogether it seems a

somewhat perilous bogie to be let loose on an unoffending railway. The boiler contained 210 $1\frac{3}{4}$ in. tubes, which were bent downwards at the smoke-box end. The total heating surface was 1217 square feet and the pressure 140 lb. The

very different design, and were directly derived by D. Jones from the old "Crewe" type of 2-4-0 engine, one of which was converted in 1873 by removing the leading axle with outside bearings and substituting an Adams bogie for the



FIG. 256—D. JONES'S CONVERTED BOGIE ENGINE, HIGHLAND RAILWAY, 1873 [Photo, Locomotive]

inside fire-box had a flat top stayed directly to the outer semicircular casing, and the grate was divided into two portions by a very deep longitudinal midfeather. The total wheel base was 6ft. 6in. + 7ft. 3in. + 7ft. $3\frac{1}{2}$ in. = 21ft. $0\frac{1}{2}$ in. The balance weights in the wheels were extensions of the bosses opposite the crank pins. The trailing axle had volute springs in addition to a very wide transverse laminated spring. The boiler was fed by pumps driven from two extra eccentrics on the driving axle. The total weight of the last six engines of 1874 was 44 tons 1 cwt., of which 27 tons 7 cwt. were carried by the coupled wheels.

These engines were very far from being a success, and E. Fletcher completely reconstructed them in 1879 to 1881, by scrapping practically the whole of the engine portions, except the centres of the coupled wheels, and reconstructing them

purpose of working over the long branch from Dingwall to Strome Ferry, on which the curves were found too severe for engines with rigid leading axles—Fig. 256. The new main line passenger engines were built in 1874 by Dübs and Co.—Fig. 257— and the design, with only slight modifications in detail and pressure increased to 160 lb., remained standard on that railway for more than twenty years. The outside framing of the old design was retained for the purpose of securing the cylinders between it and the inside frame. The cylinders were 18in. by 24in., inclined at 1 in 12; diameter of coupled wheels, 6ft. 3in., and of bogie wheels, 3ft. $9\frac{1}{2}$ in.; wheel base, 6ft. + 6ft. 9in. + 8ft. 9in. = 21ft. 6in.; heating surface of tubes, 1132 square feet; of fire-box, 96 square feet; total, 1228 square feet; grate area, $16\frac{1}{4}$ square feet; pressure, 140 lb.; the weight in



FIG. 257—D. JONES'S HIGHLAND RAILWAY LOCOMOTIVE, 1874

as 2-4-0 engines with 17in. by 26in. inside cylinders, and a single pair of leading wheels having inside bearings. The old boilers, minus the fire-box midfeathers, were retained.

The 4-4-0 Highland Railway engines were of a

working order was 41 tons, of which $14\frac{1}{2}$ tons were carried by the bogie.

The frames were of wrought iron with horn-blocks of cast steel. The fire-box was stayed by three girders on each side and two rows of direct

roof stays in the middle. The steam chests were cast separately from the cylinders, and the vertical slide valves of cast iron had flanges with rubbing strips to support them at the bottom. The valve gear was Allan's straight link. The connecting and coupling rods were of best Yorkshire iron, the ends being case-hardened, no bushes being used for the coupling rods. The chimneys of all D. Jones's "Highland" engines were double, and the outer casing was provided with louvres in front to increase the draught when the engine was running fast with an early cut-off. The neat and roomy cabs, with rounded corners, deserve notice. They were derived from the cabs introduced a few years earlier by W. Stroudley, who was chief locomotive superintendent of the Highland Railway from 1865 to 1870. Stroudley's cabs were somewhat smaller and had square corners. The cabs in the illustration were standard on the railway until 1898.

Passenger Tank Engines.—W. Stroudley's 0-4-2 side tank passenger engines for the L.B. and

the exhaust from the upper ports. The reason for this was that, to allow adequate dimensions for the crank axle, the centres of the cylinders were only 2ft. 2in. apart, which limited the space between them. Similarly, the steam ports were also divided, the two portions being, so to speak, moved upwards and downwards. This gave a clear space in the middle for the steam to pass freely from one end of the steam chest to the other. These cylinders were cast separately, but Stroudley in his larger engines cast both in one piece. He never built an engine of any class with a bogie, which he considered an unnecessary expense.

Another railway, the locomotive department of which also strongly objected to bogies, was the Great Western, and all the passenger tank engines built at Wolverhampton were of the 0-4-2 type, whilst those constructed at Swindon were of the 2-4-0 type, as in Fig. 259. The latter had outside bearings for the leading wheels only, this design being found preferable as a result of experience



FIG. 258.—W. STROUDLEY'S L.B. & S.C. TANK ENGINE, 1873-87 [Photo. Locomotive]

S.C.R., of which there were 125, built from 1873 to 1887, are illustrated in Fig. 258. The cylinders were 17in. by 24in.; diameter of coupled wheels, 5ft. 6in.; of trailing wheels, 4ft. 6in.; wheel base, 7ft. 7in. + 7ft. 5in. The heating surface varied, but the thirty-five engines built by Neilson and Co., of which the illustration shows one, had a total surface of 1029 square feet, of which the fire-box provided 85 square feet; grate area, 15 square feet; pressure, 140 lb., subsequently increased to 150 lb.; tank capacity, 860 gallons; average weight in working order 38½ tons, with 27 tons on the coupled wheels. These engines embodied all Stroudley's special features, several of which have been previously mentioned. The arrangement of exhaust ports was peculiar; they were 2½in. wide, divided into two portions each 7½in. long. The exhaust from the upper portion travelled directly to the blast pipe, but that from the lower part was taken through a passage completely round the cylinders, and connected with

gained with forty similar tank engines of 1869-71 with inside bearings. The general dimensions were:—Cylinders, 16in. by 24in.; coupled wheels, 5ft.; leading wheels, 3ft. 7in. diameter; wheel base, 7ft. 9in. + 8ft. 3in.; the boiler, 4ft. diameter inside, contained 234 1½in. diameter tubes, the heating surface of which was 1072 square feet; total heating surface, 1163.5 square feet; grate, 15.6 square feet; pressure, 140 lb.; tank capacity, 820 gallons; weight, 36¾ tons in working order, of which 26 tons were available for adhesion. These were simple, straightforward engines, which performed a vast amount of hard work for many years; in fact, the same type, but with longer side tanks, was built at Swindon until the end of 1899. The valve-rods in the earlier engines were suspended by swing links from a bracket attached to the top of the motion plate. A feature to which attention may be directed was the long "open-plated" springs, which were standard on the Great Western. These, when loaded, were

4ft. 6in. long by 4in. wide; between each main plate, short plates, $\frac{1}{2}$ in. thick, were interleaved, the length of these being 8in. at the top and 6in. near the bottom. These springs were used on account of the longitudinal sleeper track, which was hard and unyielding.

16in. by 22in.; the diameter of coupled wheels 5ft., and of bogie wheels 3ft.; wheel base, 7ft. 8in. + 9ft. + 5ft.; total, 21ft. 8in.; total heating surface, 1163 square feet; pressure, 140 lb. The weight was about 43½ tons, but later engines, by R. and W. Hawthorn, with slightly longer boilers



FIG. 259—G.W.R. TANK ENGINE, BUILT AT SWINDON, 1874-75 (Photo. Locomotive)

The 0-4-4 type of tank engine, with trailing bogie, was built to M. Kirtley's designs for the Midland Railway in 1869-70, following the lines of J. Cudworth's earlier engines of 1866. These were somewhat old-fashioned engines, with double frames for the coupled axles and the tank at the back carried on the bogie. Some engineers of that day, notably P. Stirling and E. Fletcher, preferred this arrangement of tanks for the reason that as the tanks emptied the weight on the coupled wheels was not affected to such an extent as when side tanks were used. For the Great Northern, P. Stirling in 1868-71 used 0-4-2 back tank engines, with an Adams's radial trailing axle. In 1872 he substituted a bogie for the latter,

and larger tanks, weighed 46 tons 3 cwt., of which 20 tons were carried by the bogie when the tanks and bunker were full. Later engines of the type built at Gateshead, 1880-83, had 5ft. 6in. coupled wheels, with 17in. by 22in. cylinders.

The standard 0-4-4 side tank engine with inside frames, which has been and is still used on so many British railways, was first brought out by S. W. Johnson on the Great Eastern Railway in 1872-73, when thirty engines were built by Neilson and the Avonside Engine Company to his designs. They were similar in general appearance to the later Midland tank engines—Fig. 261—by Neilson in 1875-76, also built to Johnson's designs, but the G.E. engines had

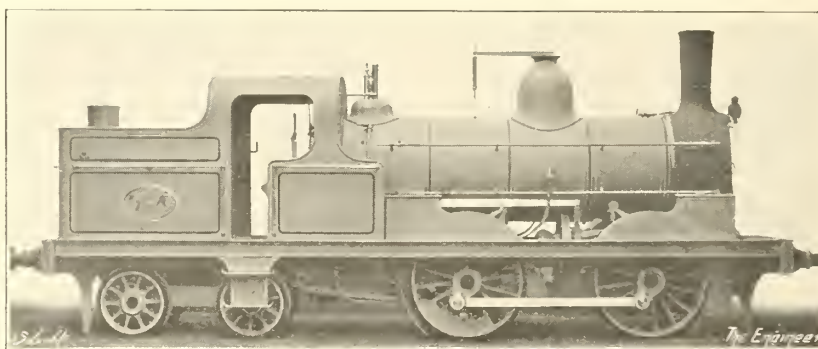

FIG. 260—E. FLETCHER'S N.E.R. BACK TANK ENGINE, 1874

and maintained this design for forty-eight engines, until 1881, when he adopted side tanks.

The best-known examples of the back tank design were E. Fletcher's North-Eastern engines of 1874-83, of which the first series—Fig. 260—were built by Neilson and Co. The cylinders were

sheet weatherboards only, whereas the M.R. engines had cabs. These locomotives were conspicuous for neatness of design and finish. The dimensions of the Midland engine illustrated were:—Cylinders, 17in. by 24in.; coupled wheels, 5ft. 6in.; bogie wheels, 3ft.; wheel base, 8ft. +

8ft. 9in. + 5ft. = 21ft. 9in.; heating surface of 221 $\frac{3}{4}$ in. tubes, 1099.4 square feet; of fire-box, 110 square feet; total, 1209.4 square feet; grate, 17.5 square feet; pressure, 140 lb. Weight in working order, 43 $\frac{1}{2}$ tons, of which 15 tons 8 cwt.

which one is illustrated, were, with the exception of one Fairlie engine to be mentioned later, the only examples on the standard gauge. The cylinders were 17in. by 22in.; diameter of bogie wheels, 2ft. 8in.; and of coupled wheels, 4ft. 8in.

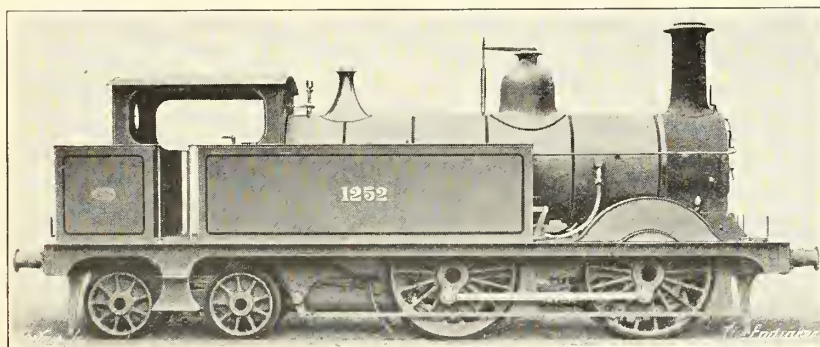

FIG. 261—S. W. JOHNSON'S MIDLAND RLY. TANK ENGINE. 1875-76

were carried on the bogie. When empty, the total weight was 37 tons 4 $\frac{1}{4}$ cwt., of which 12 tons 3 $\frac{1}{2}$ cwt. were carried on the bogie. There were 205 engines of this type built for the Midland Railway from 1875 to 1900. In the latest examples the coupled wheels were reduced to 5ft. 3in., the cylinders increased to 18in. by 24in., and the pressure to 150 lb. With larger tanks and coal capacity the weight in working order was about 52 tons, of which 21 tons 2 cwt. were carried on the bogie.

The only other type of passenger tank engine to be mentioned is shown in Fig. 262, and represents a design to be found abroad and in America. In the United States it was known as the Forney

The latter were placed somewhat closely together, the coupled base being only 5ft. 9in. The bogie wheel base was 5ft., and the total 20ft. 9in. The officially recorded weight in working order was 42 tons 3 $\frac{1}{2}$ cwt., of which 16 tons 3 cwt. were carried on the bogie. When empty the total weight was 33 tons 11 $\frac{3}{4}$ cwt., with only 10 tons 0 $\frac{3}{4}$ cwt. on the bogie.

Passenger Tank Engines with Six Wheels Coupled.—The most celebrated six-coupled passenger tank engines were W. Stroudley's small "Terriers," of which fifty were built in 1872-80 specially for working the South London line between Victoria and London Bridge, and also for the trains from New Cross through the Thames

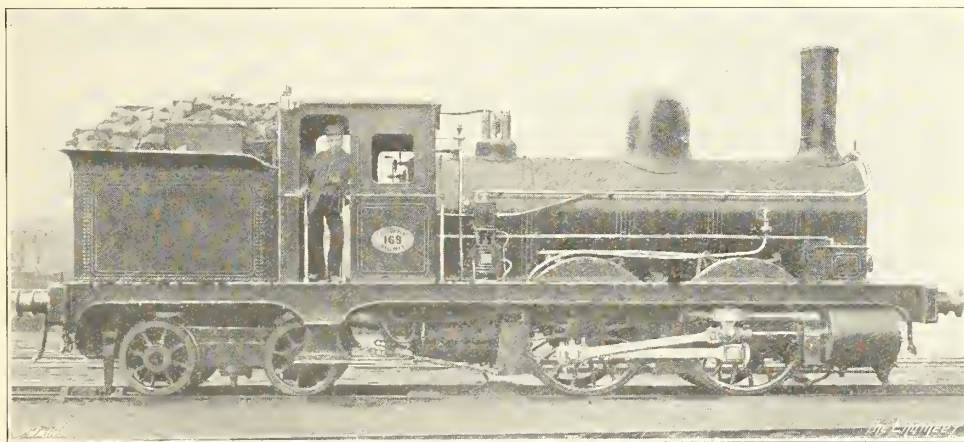

FIG. 262—CALEDONIAN RAILWAY TANK ENGINE. 1873-74

[Photo. Locomotive

engine, and has outside cylinders and the tanks at the back over the bogie. It never took root in this country owing to the objection to outside cylinders, and the four engines built by Neilson and Co., 1873-74, for the Caledonian Railway, of

Tunnel to the East London Railway. The track of the South London Railway was in a bad condition, with light iron rails, and it was to meet this contingency that these light engines were specially designed with a total weight in working

order of 24 tons 12 cwt., equally divided over the coupled wheels. The cylinders were originally 13in. by 20in., but subsequently many of them were enlarged to 14in. by 20in. The coupled

of the cylinders and prevented leakage through the joint at the bottom. One of the class, the "Brighton," was shown at the Paris Exhibition of 1878, where it was awarded a gold medal.



FIG. 263—W. STROUDLEY'S L.B. & S.C.R. "TERRIER" TANK ENGINE, 1872-80

wheels were 4ft. diameter; wheel base, 12ft., equally divided. The boiler, 3ft. 6in. diameter outside the middle ring, was pitched with its centre only 5ft. 8 $\frac{3}{4}$ in. above rail level. There were 125 1 $\frac{3}{4}$ in. tubes, which gave a heating surface of 473 square feet; total heating surface, 528 square feet; pressure, 140 lb.; tank capacity, 500 gallons; coal space, 27 cubic feet. The cylinders were cast

The "Terriers"—Fig. 263—were very successful engines, but as train loads grew too heavy for them after about twenty years' service they had to be relegated to lighter work.

Goods Engines, 0-6-0 Type.—The following are typical designs of the 1870-75 period. Fig. 264 shows the standard Kirtley goods engine with double solid plate frames on the Midland Railway.

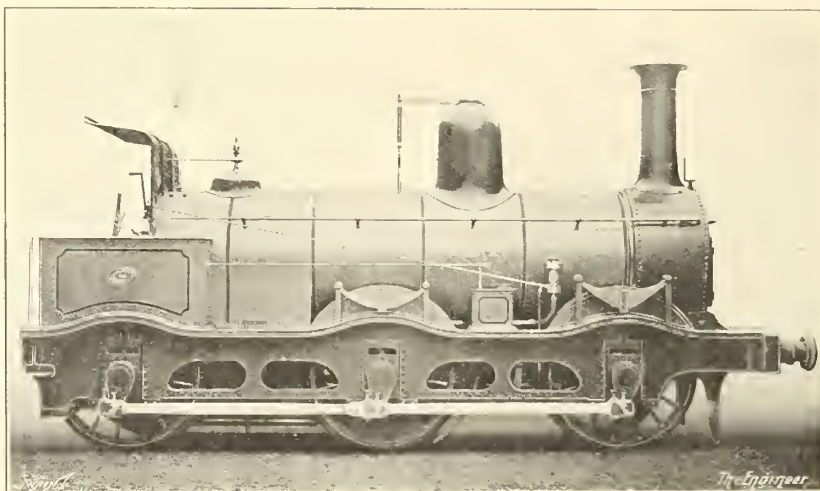

FIG. 264—M. KIRTLEY'S MIDLAND RAILWAY GOODS ENGINE, 1869-73

separately, but each was in one piece with the back cover and stuffing-box. One cylinder had a tongue on the flange of the lower side of the steam chest, which fitted into a groove in the flange of the other. This arrangement secured the parallelism

Of a very large number of these engines by various builders, only forty by Neilson had the vertical struts in the frames midway between the horns. All were excellent engines, and most of them with new boilers were in 1925 still in service.

The cylinders were 17in. by 24in.; diameter of coupled wheels, 5ft. 2½in.; wheel base, 8ft. + 8ft. 6in. The total heating surface varied from 1093 to 1128 square feet, according to the number and diameter of tubes, of which some engines had 168 2in. diameter and others 232 1½in. diameter. The fire-boxes supplied 106.7 square feet, and the grate area was 16.84 square feet; pressure, 140 lb.; total weight in working order, 35¾ to 36 tons.

Seventy goods engines of somewhat similar dimensions and general design were built for the North-Eastern Railway (706 class) in 1870-73, but they had the old plated oak outside sandwich frames, and, with the exception of a few subsequent Great Western classes, were the last engines in the country with this type of framing. For 17in. by 24in. cylinders the boilers had the liberal total heating surface of 1230 square feet. The general design was due to E. Fletcher, and fifty of the engines were built by R. Stephenson and Co., the other twenty coming from Messrs.

The cylinder centres were only 2ft. 1in. apart, allowing long bearings and thick crank webs. The coupled wheels were 5ft. diameter; wheel base, 7ft. 9in. + 7ft. 6in. The "Monkbridge" iron frames were 1½in. thick and of great depth throughout. The boiler was very large for the period, the inside diameter of the front ring being 4ft. 2½in. and of the third or back ring 4ft. 4½in., the plates being 9/16in. thick. The fire-box bottom sloped upwards from front to back to allow the trailing axle to be placed underneath. The two first engines had 311 1½in. tubes, but later examples had 247 1¾in. tubes, which provided 1321 square feet of heating surface; fire-box heating surface, 103 square feet; total, 1424 square feet; grate, 19.3 square feet; pressure, 140 lb.; weight in working order: leading, 13 tons; driving, 14 tons 12 cwt.; trailing, 11 tons; total, 38 tons 12 cwt.; weight empty, 35 tons 12 cwt.

Amongst other details may be mentioned the connecting-rods, which had marine ends, a form

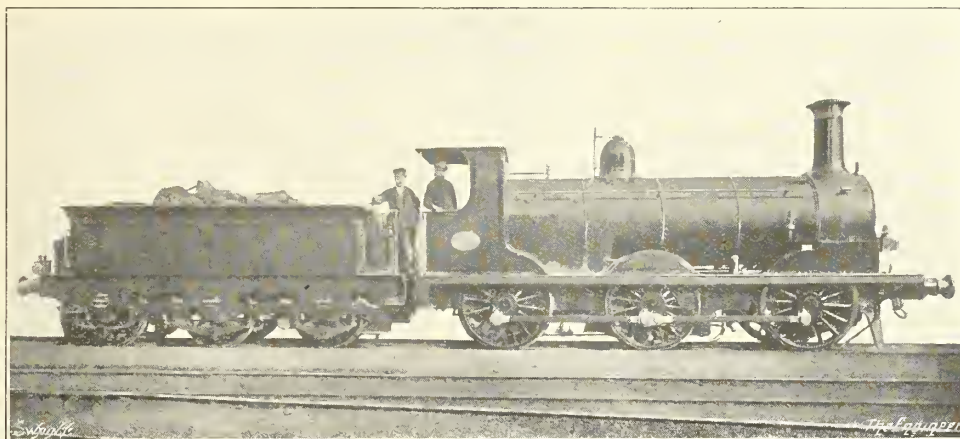

FIG. 265—W. STROUDLEY'S L.B. & S.C.R. GOODS ENGINE, 1873

Hawthorn. The drivers were unanimous in stating until many years later that these were the best goods engines on the line.

In W. Stroudley's goods engines of 1871-73—Fig. 265—for the L.B. and S.C.R. we find the first examples of the more powerful modern 0-6-0 engine, as in service to-day. The type itself was, of course, not new; it was in detailed design and dimensions that Stroudley's engines began a new era. The two cylinders, 17¼in. by 26in., with the steam chests beneath were cast in one piece. The downward inclination of the cylinders was 1 in 11½ and the upward inclination of the port faces towards the back was 1 in 16½. A direct drive from the eccentrics was provided without the intervention of rocking shafts or suspended levers. The writer cannot say definitely whether this combination of direct drive with valves underneath had been used previously; only an examination of ancient drawings in the stores of the old-established locomotive builders would settle the point.

which, though largely used at one time on the L.B. and S.C., M.S. and L., and the N.B. Railways (on the last named until recently), has never proved as successful for locomotive work as the ordinary big end with strap, bolts, and cotter. The weigh shaft was balanced by means of a coiled spring. As in Stroudley's usual practice, the inside and outside cranks were on the same side of the driving axle, necessitating large balance weights. Each of the steel piston-rods was in one piece with the crosshead. Of these twenty engines, eight were built at Brighton Works, 1871-73, and twelve by Kitson and Co., 1873-74.

As a contrast to these designs the still more powerful 0-6-0 engines—Fig. 266—designed by P. Stirling in 1871 for the main line coal trains of the G.N.R. are described. The cylinders were 19in. by 28in., and, like Stroudley's, in one piece, and with the steam chests underneath; but, unlike the Brighton design, the port faces were parallel to the cylinder centre line inclined at 1 in 11½, and

the valves were actuated by rocking shafts. The coupled wheels had a diameter of 5ft. 1in.; wheel base, 8ft. 5in. + 9ft. 2in. = 17ft. 7in., the longest then in use on a six-coupled engine in this country. The boiler contained 232 1 $\frac{3}{4}$ in. tubes; tube heating surface, 1240 square feet; fire-box, 112 square feet; total, 1352 square feet; grate area, 18.7

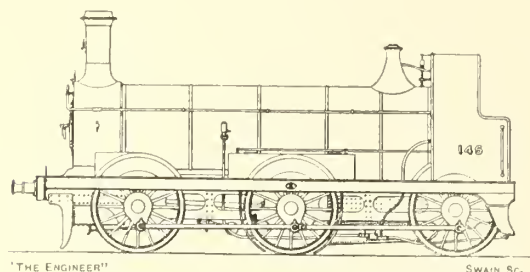

FIG. 266—P. STIRLING'S GREAT NORTHERN RAILWAY GOODS ENGINE, 1871

square feet; pressure, 140 lb.; weight in working order: leading, 14 tons; driving, 14 $\frac{3}{4}$ tons; trailing, 11 $\frac{1}{4}$ tons; total, 40 tons.

Of these engines, which were originally intended to take the place of the older "Sturrock" steam tender locomotives, only six in all were built in 1871-74 at Doncaster Works. Many years ago the writer, in a talk with Mr. Stirling, asked him why he had discontinued the type. He explained that in those days the South Yorkshire coal trains from Doncaster travelled *via* the old level line through Lincoln and Boston to Peterborough, thus avoiding the heavier gradients on the main line. But at Lincoln, where the trains always stopped, there are two level crossings intersecting two main streets, and the distance between the crossings is such that only a limited number of wagons could be accommodated between them, unless one end of the train were to hold up the street traffic. Therefore when Mr. Stirling had put a few of his large engines into service, it was found that the loads limited by the crossings was such that smaller engines could do the work.

F. W. Webb's well-known coal engines for the L. and N.W.R.—Fig. 267—of which 500 were built at Crewe between 1873 and 1892—were probably the simplest and cheapest locomotives ever made in this country. They were derived from the old Ramsbottom goods engines, the cylinders and most of the motion being similar. Their chief characteristic was the small cast iron wheel centres with I section spokes. These wheels were then 4ft. 3 $\frac{1}{2}$ in. diameter with new tires, since made 4ft. 5 $\frac{1}{2}$ in. with thicker tires. Cylinders, 17in. by 24in.; wheel base, 7ft. 3in. + 8ft. 3in. The boilers of the earlier engines had slightly smaller fire-boxes with 15 square feet of grate area. Afterwards all the boilers were standardised, and were similar to those of the 2-4-0 "Precursor" passenger engines with 980 square feet of tube heating surface and 94.6 square feet of fire-box surface;

grate area, 17.1 square feet; pressure, 140 lb.; the total weight in working order was 29 tons 11 cwt. Unlike many other types designed at Crewe during Webb's superintendency, these engines had Stephenson's link motion.

They gave good service at slow speeds for a great many years. Whether in the end they were more economical in working than those of other companies, taking everything, including loads and gradients, into consideration, cannot be definitely stated, as no figures are available, nor could scientific comparisons be made. It must be remembered that cheapness of first cost is a comparative matter, and depends not only upon design, but also upon location of works, and upon special manufacturing facilities, including cost of labour. Crewe Works at this period had special advantages, and the company made its own steel there. The standing charges against the cost of each new engine must have been low in any case, though whether they were fairly estimated in any railway works both building and repairing locomotives is another matter.

The last of the Stockton and Darlington "long boiler" mineral engines of the Stephenson type with inside cylinders were built in 1874-75. They differed only in minor details from W. Bouch's engines of 1866—Fig. 223 *ante*—and need not be illustrated. Most of the class had 5ft. wheels and 17in. by 26in. cylinders. They were also the last of their type for any English railway, and the last survivor was withdrawn from service in 1923, but is still preserved at the L. and N.E. Railway museum at York.

But just as the S. and D.R. had discarded the "long boiler" mineral engine, the Caledonian Railway at this very belated period suddenly discovered it, and during 1874-77 placed in service 39 engines of the type—Fig. 268—all of which were built by Dübs and Co. The fact is that the Caledonian had always worked mineral trains with

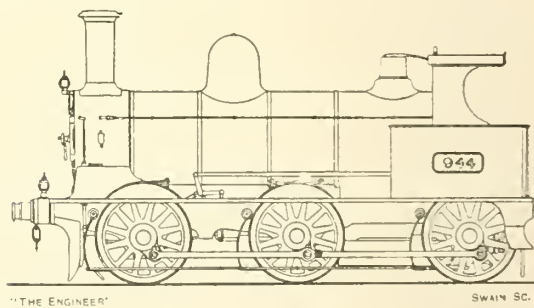

FIG. 267—F. W. WEBB'S L. & N.W.R. COAL ENGINE, 1873-92

0-4-2 engines, and when more powerful locomotives were needed, which, in addition to running on the main line, could also enter the colliery sidings, the "long boiler" 0-6-0 was really the most suitable type. The new engines differed from standard British practice in having outside cylinders, for before they appeared the number

of 0-6-0 tender engines with outside cylinders in the United Kingdom could have been counted on the fingers of one hand. Moreover, the type was never repeated on any other railway.

The cylinders were 18in. by 24in.; diameter of wheels, 5ft. 2in.; wheel base, 11ft., equally divided; heating surface of tubes, 990 square feet; of fire-box, 92.5 square feet; grate, 14.3 square feet; weight in working order: leading, 12 tons 12 cwt.; driving, 13 tons 3½ cwt.; trailing, 11 tons 8 cwt.; total, 37 tons 3½ cwt.; weight empty, 32 tons 16 cwt. Within the last few years the last of these engines has been broken up.

Main Line Goods Tank Engines.—From about 1873 and for thirty years later, the policy of the Great Western was to work many main line coal trains with 0-6-0 tank engines. The South Wales coal for London was worked between Aberdare

frames only, and it was only in 1890 that the Swindon design was modified to the Wolverhampton type on account of the reduced cost.

The "Crewe" and the "Swindon" engines for working coal trains formed a complete contrast. In one respect the Great Western had an advantage. After a certain length of service the tank engines could be and were taken off the main line trains, and used for three or four months on shunting duties before finally going into the shops for heavy repairs. This method of working was not convenient in the case of tender engines. On the other hand, the use of tank engines with limited water capacity on the main line required careful arrangements in the placing of water cranes, where the trains could be stopped without causing delay to the general traffic.

Again, both the L. and N.W. and G.W. Rlys.

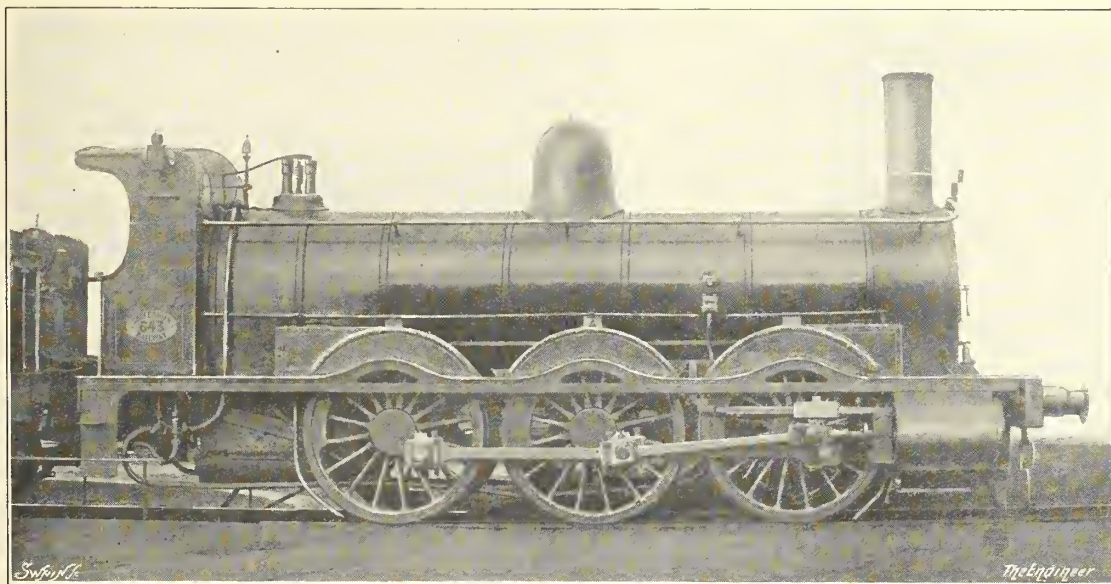

FIG. 238—B. CONNOR'S CALEDONIAN GOODS ENGINE, 1874-77

[Photo. Locomotive

and Swindon, 108 miles *via* Gloucester, entirely by tank engines, though for the purpose of keeping a clear road for expresses, only tender engines with larger wheels were used for the same trains between Swindon and London. More than 200 of the tank engines were built at Swindon from 1874 to 1881. The cylinders, 17in. by 24in., and motion were interchangeable with those of the standard main line goods engines, but the wheels, 4ft. 6in. diameter, were smaller. The heating surface varied in different batches, but was in the neighbourhood of 1212 square feet; grate, 16¼ square feet; pressure, 140 lb.; tank capacity, 1040 gallons; average weight in working order, 40 tons.

All these Swindon-built tank engines had double frames, whereas similar engines built at the company's Wolverhampton works had inside

mineral engines were very different from the standard Stockton and Darlington type with long boilers and large 5ft. wheels. In spite of the very short wheel base, 11ft. 10in., and overhanging fire-box, the S. and D. mineral engines frequently worked main line fast goods trains on the North-Eastern Railway between Middlesbrough and Leeds until about 1881, on which they used to be seen running at speeds of 30 to 35 miles per hour.

DETAILS.

Boilers and Fire-boxes.—Between 1870 and 1875, there were very few new improvements in the design of locomotive details which have left their mark upon present-day practice, and only James Stirling's steam reversing gear, already mentioned, stands out prominently. Locomotive

engineers were then more concerned with the application of steel, and with the testing of various proportions and dimensions in design.

The London and North-Western Railway led the way, about 1873-75, soon after F. W. Webb had taken charge at Crewe, in gradually abandoning wrought iron for steel in boiler construction, though for some years previously steel had been used intermittently. The steel plates had a tensile strength of 34 tons per square inch, with 25 per cent. elongation—length of test specimen not stated. They were of the same thickness as the previously used wrought iron plates, with the object, as stated by Webb, of obtaining longer life, though it may be noted that the change of material coincided with an increase of pressure from 120 lb. to 140 lb. The rivet holes were punched, those in the longitudinal seams to $\frac{3}{8}$ in. diameter and in the transverse seams to $\frac{3}{4}$ in. diameter. The plates were then annealed, and when the rings had been put together with the butt strips in place, the three thicknesses were reamed through to finished sizes.

It was during 1870 to 1874 that many attempts were made in this country to use steel fire-boxes. They were the direct result of some trials made in 1860-63 by Alex. Allan, who provided ten engines on the Scottish Central Railway with fire-boxes made from steel plates provided by Messrs. Howell, of Sheffield. The tube-plates were $\frac{3}{8}$ in. thick, the back plates $\frac{3}{8}$ in., some of the side plates were $\frac{3}{8}$ in., but the majority were $\frac{5}{16}$ in. thick. A subsequent analysis of the material showed over 0.3 per cent. of carbon, and that the plates were very free from impurities. The dimensions of the fire-boxes are not known, but most of Allan's fire-boxes of that period were from 3ft. 8in. to 4ft. in length by 3ft. 4in. wide. Many of them also had the peculiarity that the side plates were dished outwards at the front where the water space was decreased, and the stays were kept well away from the corners.

These early steel fire-boxes are the only boxes of that material ever used in this country which can truly be said to have been successful. They were all at work in 1871, when B. Connor, the locomotive superintendent of the Caledonian Railway, stated that only two of the ten had been slightly repaired. But the reason for their success remains obscure; whether it lay in the material, the dimensions, the design or in the quality of water used, was never probed to the bottom. The carbon content was considerably higher than that of the soft steel, with 0.18 to 0.2 carbon, now usual in America, but the plate thicknesses, a most important detail, do not appear to have been excessive.

As a result of the success of these fire-boxes, B. Connor made a further trial on the Caledonian Railway in 1870-71 of steel, made by the same firm, but, contrary to advice, used thicker plates. There was a fear amongst locomotive engineers

that the thin plates, especially when worn, would not provide sufficient holding power for the screwed stays. Connor's tube-plates were $\frac{3}{8}$ in., back plates $\frac{3}{8}$ in. and $\frac{7}{16}$ in. thick, and though there were some $\frac{3}{8}$ in. side plates, others were $\frac{1}{2}$ in. thick. All these fire-boxes failed, chiefly through cracks, and the plates are stated to have given way with a loud report when on the road.

A. McDonnell's experience on the Great Southern and Western Railway of Ireland at the same period was somewhat better, though in this case only two steel fire-boxes were made. They had $\frac{3}{8}$ in. tube-plates, and the other plates were $\frac{3}{8}$ in. thick. One was made of steel supplied by a Pittsburg firm, and the other by Vickers, of Sheffield. The carbon content of the Pittsburg steel was as high as 0.33. This fire-box cracked on the road and was finally taken out after a mileage of 102,966. The Vickers box wore thin at the bottom, but did not crack, and its total mileage was 171,309.

About 1872-73 five steel fire-boxes were made at Crewe by F. W. Webb for the L. and N.W.R. He stated at the time that the plates were brought out of the rollers and thrown into a large tank of cold water, after which they were put into the annealing furnace and returned again to the tank, and this process was repeated four times. It was added that a plate of this steel would bend double when cold without going through any annealing process after the last dipping, "which proved that the steel was thoroughly reliable for fire-boxes, since it would stand sudden changes of temperature."

F. W. Webb, and his works manager, T. W. Worsdell, had had much greater experience of steel than any other contemporary locomotive engineers in this country. Not only was there the established steel plant at Crewe works, but Webb, from about 1866 to 1870, had been manager of the Bolton Iron and Steel Company's works. Worsdell, during seven years with the Pennsylvania Railroad at Altoona, had put in the first steel fire-boxes used on that line, to the number of 250 to 300, and, as he subsequently stated himself, there had never been a failure.

The Crewe steel fire-boxes were unsuccessful; one or two cracked from the ring upwards, and the others were taken out. F. W. Webb ("Proc." Inst. C.E., 1882) merely stated that "to enable them to stand, they must be thin, and that meant a short life, and however soft the plates were in the first instance they appeared to harden with use." On the other hand, Worsdell was of opinion that the British design of fire-box was not suitable for steel. In America every surface had a separate plate, but in the Crewe fire-boxes a single plate went round the whole surface of the box, and he thought that was not safe practice for steel, owing to possible variation in the condition of the material in different parts of a large plate. The

smaller the plates the better the chance of the fire-box standing.

The North London Railway had a similar experience with six steel fire-boxes in 1873-74. The plates were $\frac{1}{2}$ in. thick, and were made in Sheffield. All the fire-boxes had to be taken out after an average mileage of 85,000.

Here it may be added that it has frequently been stated that the British steel makers did not supply material of suitable quality for fire-boxes. But there is no evidence to support this assertion; in fact, such evidence as exists is to the contrary. The Canadian railways at one time used British steel for fire-boxes. Francis Brown, chief locomotive superintendent of the Canadian Pacific Railway, writing in 1887 to *Engineering*, stated that he had put over 300 inside fire-boxes of British steel into locomotives, and that experience showed that the material had given most satisfactory results, and that British steels were manufactured then which answered equally well. The steel to which he referred was made by the Steel Company of Scotland, David Colville and Sons, and W. Beardmore and Co.

The riddle of the failure of the steel fire-box in British locomotive practice still remains unsolved.

Several L. and N.W.R. four-wheeled shunting engines, built at Crewe, were originally designed by J. Ramsbottom in 1864, and some at least had internal circular flue furnaces with tube plates at the front. They are introduced here to mention the water grate for burning anthracite coal, which Mr. Webb added to some of those built in 1872. The furnace was 6ft. $3\frac{1}{2}$ in. long inside, and the tubes 6ft. $9\frac{3}{4}$ in. long. Webb's water grate, which had a slight upward inclination towards the fire-hole end, consisted of 13 wrought iron tubes $1\frac{1}{2}$ in. diameter, placed in zigzag fashion transversely. They extended from the tube plate to a gun-metal box placed transversely outside the furnace beneath the fire-hole. The furnace was of $\frac{3}{4}$ in. steel with a $\frac{3}{4}$ in. steel tube plate. Water circulated from the bottom of the barrel through the grate tubes into the box. The latter was connected with the water space in the boiler above the furnace by means of two lateral tubes placed outside, the arrangement being very similar to that used to connect the original fire-box casing of the "Rocket"—L. and M. Railway—with the boiler. These tubes completed the circulation circuit. The furnaces were strengthened by angle iron rings.

John F. Stephenson, locomotive superintendent of the Southern Division of the N.E.R. at York, under E. Fletcher, constructed a few copper fire-boxes, in which the plates were bent outwards instead of inwards at the corners, so that the whole of the riveting could be done from the outside. Other advantages claimed were that no double thicknesses of plates were exposed to the fire, the seams being in the water, and that the pressure

tended to close the latter. On the other hand, an awkwardly shaped foundation ring was necessary.

F. W. Webb also tried similar outside joints for the fire-box tube plate only, which was made in two parts, of which the U shaped top portion was riveted both to the roof plate and to the bottom part of the tube plate, the riveting being done from the outside only. The sides and back of these fire-boxes were in one piece. For some reason neither of these arrangements came into general use.

Boiler Accessories.—About 1872 F. W. Webb began to place the injectors on the fire-box "front" on the footplate with an internal feed pipe carried over the fire-box roof between the girders. The pipe was bent downwards and discharged at a point near the front of the middle ring of the barrel. For this pipe one of the ordinary boiler tubes was used. The original object appears to have been the heating of the water to as high a temperature as possible between the injector and the delivery end. This principle has been used for many years, and is only being discarded of late owing to the furring up of the delivery pipe, which frequently splits.

Webb also tried a peculiar blast pipe on the similar multiple jet principle of W. Bouch—Fig. 227 *ante*—but of different construction. Below the nozzle the blast pipe was widened, and out of the chamber so formed four small tubes conveyed part of the exhaust into an annular chamber at the foot of the chimney. The writer believes that it was termed a "cumulative blast pipe"; it had the object of preventing the drawing of cinders from the fire-box to the smoke-box by shunting part of the direct blast from the nozzle, the shunted portion through the four tubes coming into action later as an additional soft annular blast in the chimney itself.

Tubes.—Until 1870 the tube diameter in the great majority of boilers was 2 in., though Ramsbottom, and his successor Webb, used $1\frac{1}{2}$ in. tubes. The tube length, except in the "long boilers," usually lay between the limits of 10ft. 2 in. and 11ft. 9 in. It has already been mentioned that P. Stirling in 1869 tried tubes $1\frac{9}{16}$ in. diameter, though he was one of the few engineers whose standard tubes at that time were only $1\frac{3}{4}$ in. diameter. During 1871-74 nearly all his contemporaries, including M. Kirtley, S. W. Johnson—then on the G.E.R.—W. Stroudley, E. Fletcher, and James Stirling, unanimously came to the conclusion that the 2 in. tubes were too large, and most of them adopted a diameter of $1\frac{3}{4}$ in. or $1\frac{9}{16}$ in., at the same time increasing the number of tubes to give a heating surface approximately the same as before. An example from the Midland may be cited to show the effect of the small tubes. On this line the tubes were somewhat longer than the average, being 11ft. 3 in. to 11ft. 9 in., and the 2 in. tubes might have been

expected to give better results than in the case of shorter boilers. The twenty 2-4-0 express engines, by Neilson, 1871—890 class, Fig. 246 *ante*—had 232 $1\frac{1}{2}$ in. tubes, whilst a number of otherwise similar engines, built at Derby in 1872-73, had 169 to 180 2in. tubes. The former engines steamed excellently, even too well, if that be possible, since the drivers used to say that, with an average load, whatever care they took to avoid waste, it was all they could do to prevent the engines from blowing off the whole way during a journey. The writer can corroborate from his own observations that these engines were rarely to be seen on a fast express without a faint "white feather" rising from the safety valves on the dome. The other engines with the larger tubes generally required "coaxing." The non-conducting film of gas on the inner surface of the small tubes seems to have been scoured off by the rapid flow through them, an effect which probably did not occur to the same extent with the 2in. tubes. But the small tubes had the defect that they required considerably more care in cleaning in the sheds, and as there were more of them the time required and the cost of cleaning were greater. In 1874 S. W. Johnson compromised by adopting $1\frac{3}{4}$ in. tubes, which remained standard for about ten years, after which the diameter was again reduced, this time to $1\frac{1}{2}$ in. Nearly all the 1872-73 boilers with 2in. tubes were taken out of the express engines in 1875 to 1878 and replaced by new boilers with $1\frac{3}{4}$ in. tubes, the old boilers being used for other, mostly goods, engines. But the boilers with the $1\frac{1}{2}$ in. tubes remained on the express engines until worn out at the end of sixteen to eighteen years' hard service. Stroudley and others also discarded the $1\frac{1}{2}$ in. tubes and, like Johnson, compromised with tubes $1\frac{3}{4}$ in. diameter. Incidentally it may be added that James Stirling, who retained $1\frac{1}{2}$ in. tubes longer than his *confrères*, hinged the blast pipe, so that it could be turned down to enable the middle tubes to be cleaned thoroughly.

On the great majority of railways brass tubes were used, but W. Bouch on the Stockton and Darlington Railway used Low Moor iron, and J. Armstrong on the G.W.R. had discarded brass for Staffordshire iron. The practice on the London and North-Western was in a state of transition. A large number of goods engines had iron tubes, but the "Precedent" express engines of 1874-75 had tubes of solid drawn copper. The life of brass tubes was much greater, the statistics showing an average of about $2\frac{1}{2}$ to 1 in the mileage in favour of brass over iron. Brass tubes, however, had one defect in that when worn they burst suddenly without warning, whereas iron tubes generally gave warning of a cracked seam by leaking, though this leakage could not always be distinguished from that at the tube plates. The latter leakage was a constant source of trouble with iron, and afterwards with steel tubes, whereas brass tubes were generally tight, and caused little

trouble in this respect. A few years later S. W. Johnson discarded brass for a "red metal" composition.

Motion.—The more important details have already been mentioned in describing the various engines. For inside cylinders four slide bars were almost universal except on the L. and N.W.R., on which two bars were always used. Stroudley's connecting-rods on the L.B. and S.C.R. were of circular section and were turned in the lathe. The big ends of marine pattern which he introduced in 1871 have already been mentioned.

In 1870, before leaving the Highland Railway for the "Brighton" line, W. Stroudley made an interesting alteration to one or two of the existing 2-4-0 outside cylinder engines. The stroke was lengthened from 22in. to 23in., retaining the old cylinders, but using thinner pistons. To effect this the new outside crank pins had the connecting-rod bearing $\frac{1}{2}$ in. excentric with the coupling-rod bearings, the crank length of the latter remaining 11in. as before. This arrangement was reintroduced nearly thirty years later by Mr. H. A. Ivatt in the Great Northern "Atlantics."

A coupling-rod joint for the driving pin—Fig. 269—was invented by John F. Stephenson, of

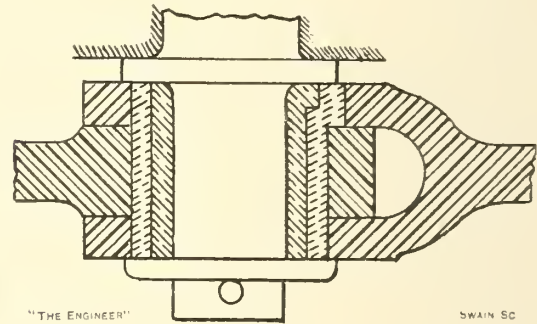

FIG. 269—J. F. STEPHENSON'S COUPLING ROD JOINT

York, and fitted to a few North-Eastern six-coupled engines. The inner bush, in which the pin worked, was of bronze, and the outer bush of steel. Both bushes had square snugs solid with them to prevent rotation in the forked rod, but the straight rod was free to rotate through an angle with respect to the outer bush. Its use on the N.E.R. was given up, being considered too stiff and somewhat troublesome to take down, but Webb on the L. and N.W.R. fitted a large number of engines during many years with this arrangement.

Wheels and Spring Gear.—Cast iron wheel centres are of very ancient origin, and they have always been used more or less intermittently, especially on some of the Scottish railways. T. Wheatley, on the North British Railway, built a large number of six-coupled tender mineral and shunting tank engines with 4ft. cast iron wheels, the spokes of which were of T section. These

came out from 1870 until 1874. There were also a few goods engines with 5ft. wheels of the same type. Wheels of I section were made at the Dublin works of the Dublin and Kingstown Railway about 1840 (see *The Engineer*, June 24th, 1898). Webb's cast iron wheels of I section first appeared on the L. and N.W.R. in 1872. They have been very successful for wheel diameters—on tread—up to 4ft. 6in. and are still made at Crewe for slow speed engines. In 1880-83 Mr. Webb built a number of fast goods engines with cast iron wheels 5ft. 2½in. diameter, and Sir John Aspinall from 1882 used similar wheels 5ft. 1¼in. diameter on the Great Southern and Western Railway, Ireland. The experience with the larger cast iron wheels does not appear to have been quite so satisfactory, for they subsequently disappeared from all of the railways mentioned, though it should be added that the introduction of cast steel as a material for wheel centres seems to have had much to do with the change.

From 1868 to 1874 there was a recrudescence of the movement in favour of using compensating levers between the springs of the coupled wheels of 2-4-0 engines, and amongst others M. Kirtley on the Midland, S. W. Johnson on the Great Eastern, following R. Sinclair's previous practice on the same railway, and B. Connor on the Caledonian used them. Although in theory the levers were at one time supposed to equalise the static spring-borne loads of the driving and trailing axles, or otherwise give facilities for weight distribution, provided that the friction of the large fulcrum pins did not upset the calculation, which it generally did to a considerable extent, there were disadvantages. There could be no three-point suspension in the case of a 2-4-0 engine unprovided with a transverse spring at the front, and the spring-borne base was shortened, giving the engine a greater tendency to "gallop." John Robinson, of Sharp, Stewart and Co., was one of the first to point out, as early as 1864, that the real advantage of the compensating lever was that the second spring connected by it took over part of the deflection of the first spring when passing over uneven track. But such track was uncommon on lines in this country, and the practical results were such that the compensating levers were afterwards, about 1876, removed from

the Midland and other engines. Fig. 246 *ante* shows the arrangement of lever on the Midland engines.

Counter-pressure Braking.—About 1870 J. Ramsbottom applied the Le Chatelier counter-pressure system to about twenty L. and N.W. engines working coal trains in the Abergavenny district, where the gradients are heavy, but although the cylinders were provided with hot water injection it was found that they were badly scored. The failure in this country of an apparatus, which has been successfully used for many years in France, may be partly ascribed to want of care on the part of the drivers. The Midland also applied the Le Chatelier brake to No. 892 and one or two other express engines of the type shown in Fig. 199 *ante*, some of which were working the first Pullman express trains, but the apparatus was likewise removed after two or three years' trial.

An apparatus known as "Bouch's Steam Retarder" was applied to a large number of engines on the Stockton and Darlington section of the N.E.R. A five-way branch was fitted under the cylinders. Live steam entered this branch from which it was distributed by four pipe connections to the ends of the two cylinders. When the main steam supply was shut off from the steam chest and the engine reversed, the supplementary steam through the branch entered the cylinders, acting as a cushion against which the pistons worked. The connections of the branch pipes were made to the cylinder cock branches, and the cocks themselves were done away with. Excessive compression was avoided by the passing of part of the steam through the pipe connections from one end of the cylinder to the other, as is now done in the by-pass attached to the cylinders of many superheater engines. There was also a connection to a three-way cock, of which one branch went to the exhaust and another to a pipe passing backwards to the tender tank. By these means during normal working part of the exhaust could be returned to the tender tank, and the steam and water ordinarily blown out of the cylinder cocks was also returned to the tender. When the engine was reversed and the steam retarder was in operation, the communications with the exhaust and with the tender were shut off.

Chapter XV.—1876-81

2-2-2 EXPRESS ENGINES.—The Great Western remained the only railway which still adhered to Stephenson's early type with double frames and four bearings for the driving axle. This type, with considerably increased dimensions, was built at Swindon until

4ft. diameter; wheel base, 8ft. 6in. + 9ft. 2in. The boiler, 11ft. long by 4ft. 2in. diameter, contained 228 $1\frac{1}{2}$ in. tubes and carried 140 lb. pressure; fire-box heating surface, 115 square feet; total, 1214 $\frac{1}{2}$ square feet; grate area, 19.3 square feet; weight in working order: leading, 10 tons 3 cwt.;

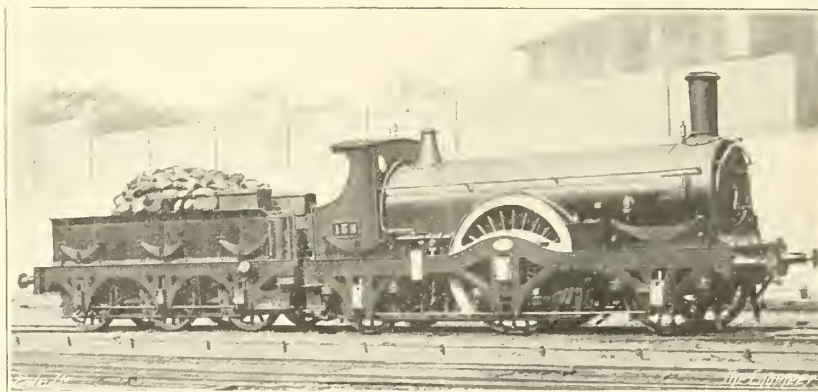

FIG. 270—W. DEAN'S G.W.R. EXPRESS ENGINE. 1878-79 [Photo. Locomotive]

1892. The ten engines—Fig. 270—Nos. 157 to 166, of 1878-79, by William Dean, were probably the most graceful express engines of their day, and the broad polished brass splasher bands, though not utilitarian from a modern standpoint, certainly added to their artistic appearance. A return was made to the old sandwich frames with oak planking. The reasons for the continued use of these frames on the G.W.R. were given on page 47 *ante*.

driving, 16 tons 10 cwt.; trailing, 9 tons 10 cwt.; total, 36 tons 3 cwt. These engines performed excellent work for twenty years on the express trains from London to Wolverhampton, and also to Swindon.

4-2-2 Express Engines.—The first "single" engines with inside cylinders and single inside frames and leading bogie made their appearance in 1877 on the Great Western broad gauge—Fig. 271. They were not new, but conversions of the



FIG. 271—G.W.R. BROAD GAUGE BOGIE EXPRESS ENGINE, 1877 [Photo. Locomotive]

The boilers were domeless, as in J. Armstrong's express engines of 1875. The cylinders were 18in. by 24in.; driving wheels, 7ft.; carrying wheels,

4-2-4 Bristol and Exeter tank engines of 1868-73 into tender engines by the substitution of trailing wheels 4ft. 6in. diameter for the hind bogie, and

at the same time the old 8ft. 10in. driving wheels were replaced by new wheels 8ft. diameter with flanges. The derailment of the "Flying Dutchman" in 1876, when running at a high speed near Bourton, between Taunton and Bristol, was responsible for the modification. The real cause of the accident was defective permanent way, but as the driving wheels were then flangeless, guidance of the engine was thrown entirely upon the bogies, and it was considered safer to alter the engines to the form illustrated. The cylinders remained 18in. by 24in., and the old boilers with 1235 square feet of heating surface were retained. These engines ran from the Bristol end in turn with the 8ft. singles of the Gooch type, "Great Britain" class, but were by no means so well liked. Two of them lasted until about two years before the broad gauge was abolished in May, 1892.

On the Great Eastern Railway the fastest express trains had up to this time been worked by Sinclair's 7ft. outside cylinder 2-2-2 engines of 1862-67, two of which had been rebuilt by S. W. Johnson in 1872 with leading bogies of the Adams

doors at the front to give the driver direct access to the platforms. The very long 7ft. base of the bogie, which was of the Adams sliding type, may be noted. The writer, when standing on a wayside platform, sometimes remarked the lateral swaying motion of these engines when they were running at high speeds, which was in the nature of a gentle movement of long amplitude, very unlike the short sharp jerky motion of the L. and N.W.R. outside cylinder 2-2-2 engines of the "Lady of the Lake" class, with short wheel base and no bogie. Another characteristic of the G.E.R. engines was the astonishing manner in which they could climb the Bethnal Green bank out of Liverpool-street with fifteen and sixteen six-wheeled coaches, frequently without slipping, and they certainly bore testimony to P. Stirling's views on the grip of large driving wheels on the rails. A number of them were afterwards modified by James Holden, who fitted them with new 17½in. cylinders and upright direct-driven rectangular slide valves inside. The smaller cylinders were for the purpose of allowing a modification of the framing to

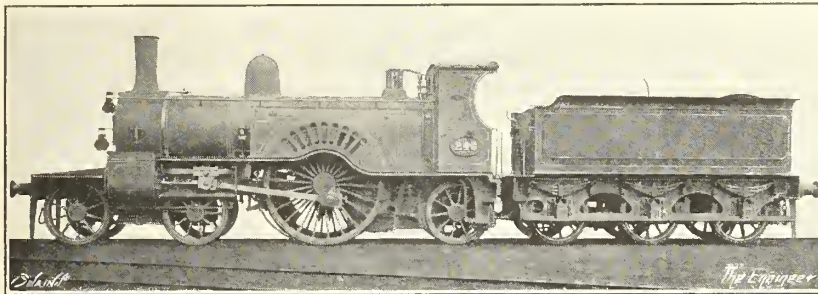

FIG. 272—M. BROMLEY'S G.E.R. EXPRESS ENGINE, 1879

sliding type, and 17in. cylinders. But they had become too light, and in 1879 Massey Bromley designed the larger engines shown in Fig. 272, the first ten of which were built by Dübs and Co., followed by ten more in 1881-82 by Kitson and Co. These engines were somewhat on the lines of P. Stirling's G.N.R. 8ft. singles, but their details were very different. The cylinders were 18in. by 24in., with the valves on the top driven from inside excentrics and Stephenson motion, which actuated rocking shafts passing through the frames, a distinctly American feature. The slide valves were circular, of a form similar to that introduced by F. W. Webb, to be described subsequently. The driving wheels were 7ft. 6in. and both bogie and trailing wheels 4ft. diameter; wheel base, 7ft. + 7ft. 10in. + 8ft. 3in. = 23ft. 1in.; heating surface of the first ten engines, 1205.6 square feet, towards which the fire-box contributed 110.4 square feet; grate, 17.1 square feet; pressure, 140 lb.; weight in working order: bogie, 16 tons 16½ cwt.; driving, 15 tons 2 cwt.; trailing, 9 tons 5¼ cwt.; total, 41 tons 13¾ cwt. Single slide bars were used. The cabs were provided with

avoid the considerable offset at the leading end.

2-4-0 Express Engines.—S. W. Johnson's engines for the Midland Railway, of which a very large number were built at Derby, and by Dübs and Neilson in 1876-1881, are representative of a favourite type. Fig. 273 shows an engine built by Neilson, one of which was sent to the Stephenson Centenary at Newcastle in 1881. The first ten engines built at Derby in 1876, No. 1 class, had driving wheels 6ft. 2½in. diameter when new, and thereon hangs an experience somewhat similar to that with the L. and N.W. "Precursors." They were built specially to run the Scotch expresses between Skipton and Carlisle, 86¾ miles, and for that purpose the driving wheels were made smaller than the Midland standard. From Skipton the line rises for eight miles at about 1 in 150, falls five, averaging 1 in 200, rises 15 miles at 1 in 100 to Blea Moor Tunnel, and then undulates for 10 miles, with a total slight rise to Ais Gill summit. The 48¼ miles thence to Carlisle are nearly entirely downhill, with a few undulations, and the line drops 1100ft. in the whole distance. The booked speed of the expresses was 43 to 44½ miles per

hour, start to stop. Johnson's engines were apparently in some respects more suitable for their work than were the "Precursors"; not only were the wheels 8 in. larger, but the boiler, with 1225 square feet of heating surface, was considerably

successor, H. Smellie, made 6 ft. 9 in. the standard size for express engines. The latter also discarded Stirling's rigid centre pin bogie, in place of which his engines—Fig. 274—built at Kilmarnock in 1879-80, had one leading axle with $\frac{1}{2}$ in. lateral

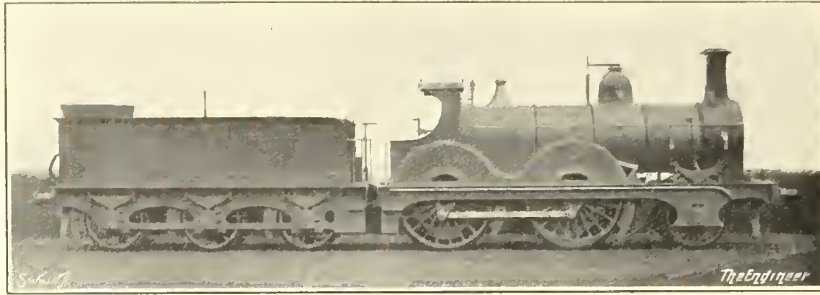

FIG. 273—S. W. JOHNSON'S MIDLAND RAILWAY EXPRESS ENGINE, 1880-81

larger and more efficient. The steam ports for the 17 in. by 24 in. cylinders were 15 in. by 1 $\frac{1}{4}$ in., area 18 $\frac{3}{4}$ square inches, as compared with 21 square inches for cylinders of the same size in the "Precursor." On the other hand, ports of the same size did not affect the running of the similar Midland engines with 6 ft. 8 $\frac{1}{2}$ in. wheels. The No. 1 class, with 6 ft. 2 $\frac{1}{2}$ in. wheels, were not successful; the drivers complained that the wheels were not large enough and that the engines had to be "forced along." Two of them broke their steel crank axles when running, after mileages of 47,447 and 37,524 respectively, and in one case the train was saved from disaster only by a prompt application of the Westinghouse brake. A third crank axle was flawed and had to be taken out after 27,132 miles. There is no reliable evidence that the broken crank axles were the direct result of wheels too small for high speeds; in all likelihood there were other more important factors. But what is certain is that the engines were then taken off the fast expresses and replaced by others having 6 ft. 6 in. and 6 ft. 8 $\frac{1}{2}$ in. wheels. Further, the Midland never afterwards built any express engines with wheels less than 6 ft. 6 in., and the majority of the coupled engines have 6 ft. 9 in. and 7 ft. wheels to this day. Even many of the later 4-4-0 engines, which had 6 ft. 6 in. wheels, have been reconstructed with 7 ft. wheels.

The engines illustrated in Fig. 273 had 18 in. by 26 in. cylinders, 6 ft. 9 in. coupled wheels, and 4 ft. 3 in. leading wheels; wheel base, 8 ft. + 8 ft. 6 in.; fire-box heating surface, 110 square feet; total heating surface, 1194 $\frac{1}{2}$ square feet; grate, 17 $\frac{1}{2}$ square feet; pressure, 140 lb.; weight in working order, 39 tons 10 cwt., of which 26 tons 12 cwt., were available for adhesion. All have done excellent service with heavy trains at high speeds in their day, and are still at work.

The Glasgow and South-Western Railway, in spite of its heavy gradients between Glasgow and Dumfries, never experimented with small wheels. James Stirling adopted 7 ft. 1 in. wheels, and his

play in each direction and double inclined-plane control. The design with inside frames throughout had the general appearance of Webb's "Precedents," but the engines were much more powerful and the details were very different. The boiler was of the Stirling domeless type, with direct stayed fire-box, but the safety valves were placed on the barrel instead of above the fire-box. The cylinders were 18 in. by 26 in.; diameter of coupled wheels, 6 ft. 9 $\frac{1}{2}$ in., and of leading wheels, 4 ft. 4 $\frac{1}{2}$ in. The boiler, 4 ft. 2 in. diameter outside the smallest ring, contained 240 1 $\frac{1}{2}$ in. tubes; fire-

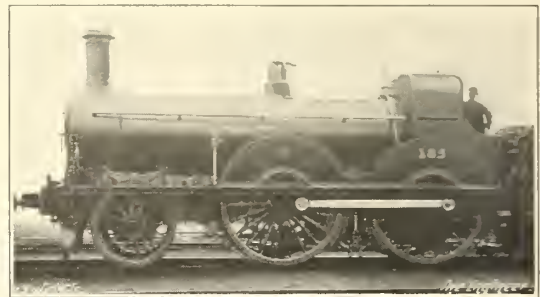

FIG. 274—H. SMELLIE'S G. & S.W.R. ENGINE, 1879-80

box heating surface, 101 square feet; total, 1206 square feet; grate area, 16 square feet; pressure, 140 lb.; weight in working order, 38 $\frac{1}{2}$ tons, of which 11 tons 12 cwt. were carried on the leading axle.

Leading Bogies.—The leading bogie began to make its mark as a feature of express engine design, but it was, nevertheless, several years before it established a permanent footing. In addition to W. Adams, two other engineers, D. Drummond on the North British in 1876, and William Kirtley on the L.C. and D.R. in 1877, adopted it permanently. In the case of Drummond, improvement in the curving properties of the engines required to work over the sinuous Waverley route between Edinburgh and

Carlisle was the main consideration, and a similar argument may also apply to Kirtley's "Chatham" engines. In 1876 S. W. Johnson designed the first of his Midland 4-4-0 engines, with 6ft. 6in. coupled wheels and 17½in. by 26in. cylinders—Fig. 275. They were built by Kitson and were specially intended for the severe gradients and curves of the Derby-Manchester line over the Derbyshire Peak district. They were followed in 1877 by twenty 7ft. coupled express engines, which ran chiefly between London, Leicester and Leeds, as well as over the Peak; but during 1877-81 the construction of bogie engines ceased on the Midland, and the succeeding eighty-five express engines were of the 2-4-0 type. The width between axle-box flanges of the leading axle of the latter engines was 1in. greater than that of the hornblock faces, though no inclined plane control was used, except in the case of twenty engines built in 1874. This simple arrangement was always

does not occur in rigid centre pin bogies. It was not until 1882 that S. W. Johnson definitely decided that the 4-4-0 engine was preferable to the 2-4-0, and since that time no engines with single leading axles have been built for the Midland. H. Smellie discarded, in his succeeding designs from 1883 onwards, the Cortazzi axle-boxes previously used, and adopted the Adams bogie. It is hardly too much to say that the main reason why several engineers in this country finally decided on bogies was that the weight on the leading axle had increased to such an extent that it was considered preferable to carry the front end on two axles.

The type of bogie in general use was the Adams sliding type, with spring control, but in 1877 A. McDonnell introduced the American pendulum link bogie on the Great Southern and Western Railway of Ireland. In that case the bogies were provided for small passenger engines employed

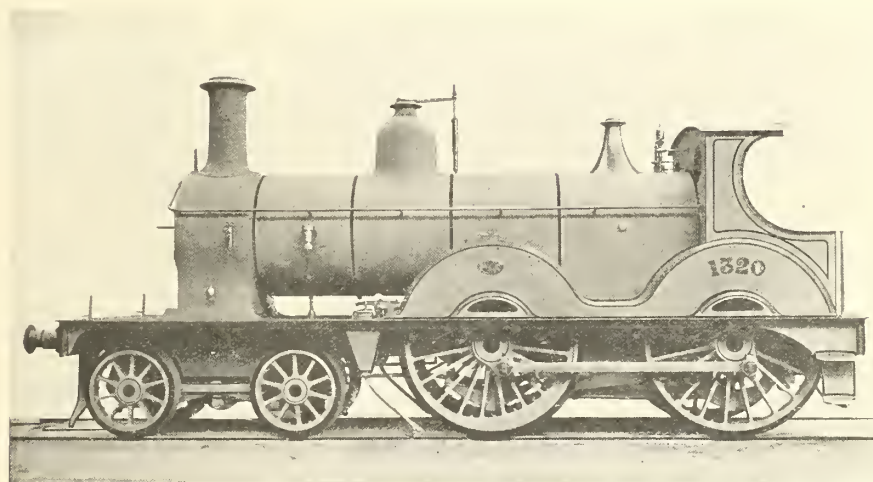

FIG. 275.—S. W. JOHNSON'S FIRST TYPE OF 6ft. 6in. BOGIE ENGINE FOR THE MIDLAND RLY., 1876

successful on the Midland and other companies' engines with long outside leading bearings, and the engines ran very steadily at high speeds. The excellence of the permanent way had much to do with this, but a 2-4-0 engine with a long wheel base does not tend to sway laterally so much as engines with a short base of 15ft. 6in. or under. The Great Western used 2-4-0 engines with wheel bases varying from 16ft. 9in. to 17ft. 6in., the leading axle having simple lateral play, and the writer can testify from personal experience that they "rode" remarkably well, even on the very sharp curves over the Cotswolds, though on this particular section a bogie would certainly have been preferable. The flange wear of the leading tires was not abnormal. What does not seem to have been fully appreciated in 1876-77 was the good effect of the controlling springs of a leading bogie in pulling the front of the engine round towards the inside of the curve, an effect which

on the Mallow, Killarney and Tralee line, on which the curves are very severe. The pendulum link bogie was brought over to English railways from Ireland by McDonnell in 1884, followed by Sir John Aspinall in 1886, and H. A. Ivatt in 1896, though all the locomotive-building firms had for many years previously constructed it for the Dominions and South American railways.

4-4-0 Engines with Inside Cylinders.—D. Drummond's North British engines by Neilson are shown in Fig. 276. The cylinders were 18in. by 26in.; coupled wheels, 6ft. 6in., and bogie wheels, 3ft. 6in. diameter; bogie wheel base, 6ft. 6in.; coupled wheel base, 9ft.; total base, 22ft.; total heating surface, 1193 square feet; pressure, 150 lb.; weight in working order about 43½ tons, of which 14 tons were carried on the bogie. The length, 9ft., of the coupling-rod was unusual at that time; its throw was short, as in Stroudley's engines. The combined sand-box and

splasher was a modification of that used in M. Kirtley's Midland engines. It was neat, but gave the driver little room in which to oil the big-ends and eccentrics. Moreover, the arrangement, as originally applied, was unsafe, and on one

bogie, 14 tons $2\frac{3}{4}$ cwt.; driving, 14 tons $8\frac{3}{4}$ cwt.; trailing, 13 tons $9\frac{3}{4}$ cwt.; total, 42 tons $1\frac{1}{4}$ cwt.; weight empty, 38 tons $19\frac{1}{2}$ cwt. The sand-boxes were beneath the platforms as in Beyer's engines. The tenders, as in P. Stirling's engines of that



FIG. 276—D. DRUMMOND'S BOGIE ENGINE FOR THE NORTH BRITISH RAILWAY, 1876-78

occasion, during a gale on the route between Carlisle and Edinburgh, the wind lifted one of the sand-box lids, hurling it through the cab window and severely injuring the driver. Afterwards the lids were secured by chains. One of these engines was shown at the Stephenson Centenary of 1881.

The only other engine which needs illustration is the first of S. W. Johnson's 7ft. coupled engines by Dübs, 1877—Fig. 277—a type which, with subsequent variations in detail and boiler pressure,

time, had the springs behind the frames, an awkward position in the case of broken plates. In subsequent tenders the springs were placed outside, below the platforms, and those illustrated were subsequently altered. Their tank capacity was 2750 gallons.

Engines of this type were built with 7ft., 6ft. 9in., and 6ft. 6in. coupled wheels. In 1885 the pressure was raised to 160 lb., and between 1892 and 1896 the cylinders were enlarged to 18½in. by 26in. and the wheel base was length-

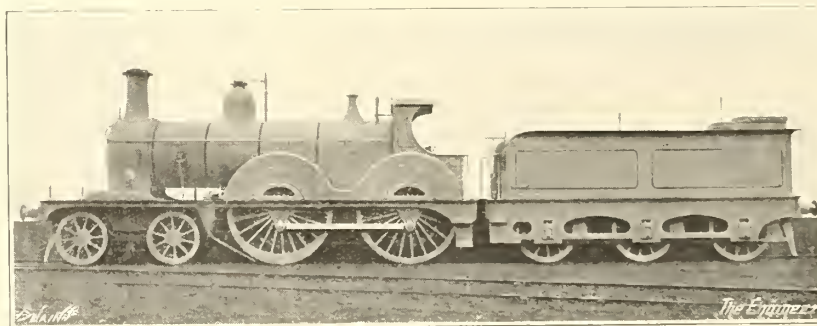

FIG. 277—S. W. JOHNSON'S 7ft. COUPLED ENGINE FOR THE MIDLAND RAILWAY, 1877

was standard on the Midland Railway for many years. Cylinders, 18in. by 26in.; wheels, 3ft. 6in. and 7ft.; wheel base, 6ft. + 7ft. + 8ft. 6in. = 21ft. 6in.; fire-box heating surface, 110 square feet; total 1313 square feet; grate, 17.5 square feet; pressure, 140 lb.; weight in working order:

ened. They had Stephenson's link motion and slide valves. Similar engines with other forms of valves and motion will be mentioned subsequently.

Charles Sacré's 4-4-0 engines—Fig. 278—built at Gorton Works, 1877-80, for the main line expresses of the Manchester, Sheffield and Lin-

colnshire Railway, had outside bearings. The bogie had inside bearings only, though the outside frame of full depth was carried in front of it to the buffer plate, a peculiar design, which added unnecessary weight at the front end. Cylinders,

4-4-0 *Engines with Outside Cylinders*.—In 1876-77 Sharp, Stewart and Co. built 20 engines for the L. and S.W.R. to the designs of W. G. Beattie—Fig. 279. The cylinders, 18½ in. by 26 in., had piston valves, which had defects similar

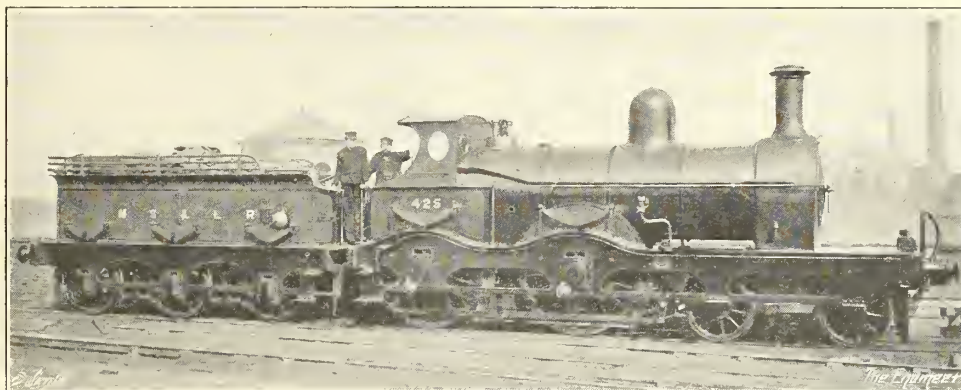

(Photo. *Locomotive*)

FIG. 278—C. SACRE'S 4-4-0 ENGINE FOR THE MANCHESTER, SHEFFIELD & LINCOLNSHIRE RLY., 1877-80

17 in. by 26 in.; driving wheels, 6 ft. 3 in., and bogie wheels, 3 ft. 3 in. diameter; wheel base, 6 ft. + 6 ft. 9½ in. + 8 ft. = 20 ft. 9½ in. The boiler was of the large diameter of 4 ft. 5 in. inside; fire-box heating surface, 94 square feet; total, 1016 square feet; pressure, 140 lb.; weight in working order, 41 tons 1 cwt. These engines worked over the heavy road between Manchester and Retford, and also between Liverpool and Hull. One of them broke a crank axle near Penistone in 1884, when

to those of Bouch's valves for the Stockton and Darlington engines. The trapped water had no suitable means of escape, and a long casualty list of broken and bent valve spindles resulted. The coupled wheels were 6 ft. 7 in., and bogie wheels 3 ft. 3 in. diameter; wheel base, 6 ft. 6 in. + 7 ft. + 9 ft.; total heating surface, 1216 square feet; pressure, 140 lb. Weight in working order: bogie, 16 tons 5 cwt.; driving, 13 tons 7 cwt.; trailing, 13 tons 16½ cwt.; total, 43 tons 8½ cwt. The

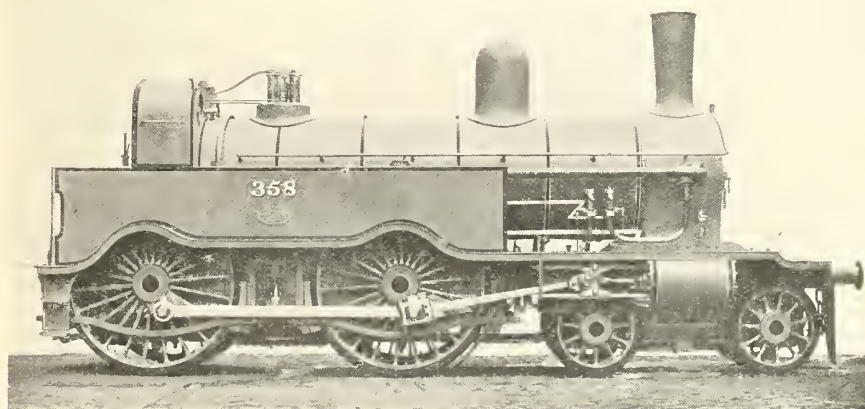

FIG. 279—W. G. BEATTIE'S 4-4-0 ENGINE, LONDON AND SOUTH-WESTERN RLY., 1876-77

travelling at high speed. The engine and tender kept on the embankment, but the jolt caused a defective horse-box coupling to break, and the train was hurled down the side with the loss of 24 lives, including that of Massey Bromley, who had three years previously retired from the post of chief locomotive engineer of the G.E.R.

coupling-rods were placed next to the wheels with the connecting-rods outside, an awkward arrangement in case the coupling-rods had to be taken down; with the additional defect of spreading the cylinder centres further apart. They were unfortunate engines; in addition to the trouble with the valves, they were "over-cylindrical"

and would not steam satisfactorily, though after liners had been put into the chimneys they were somewhat improved. W. Adams subsequently rebuilt a few of them, and reduced the cylinders to 17in. diameter. The remainder were broken up after about twelve years' service. They were the last express engines to be built with Beattie's patented fire-boxes.

The five Caledonian 4-4-0 engines—Fig. 280—were built by Neilson, 1877, to the designs of G. Brittain. The cylinders were 18in. by 24in. placed at 6ft. 3in. centres, and the connecting-rods, as in the L. and S.W.R. engines, were outside the coupling-rods. Coupled wheels, 7ft. 2in. diameter; bogie wheels, 3ft. 4½in. diameter; wheel base, 6ft. + 6ft. 7½in. + 8ft. 7in. = 21ft.

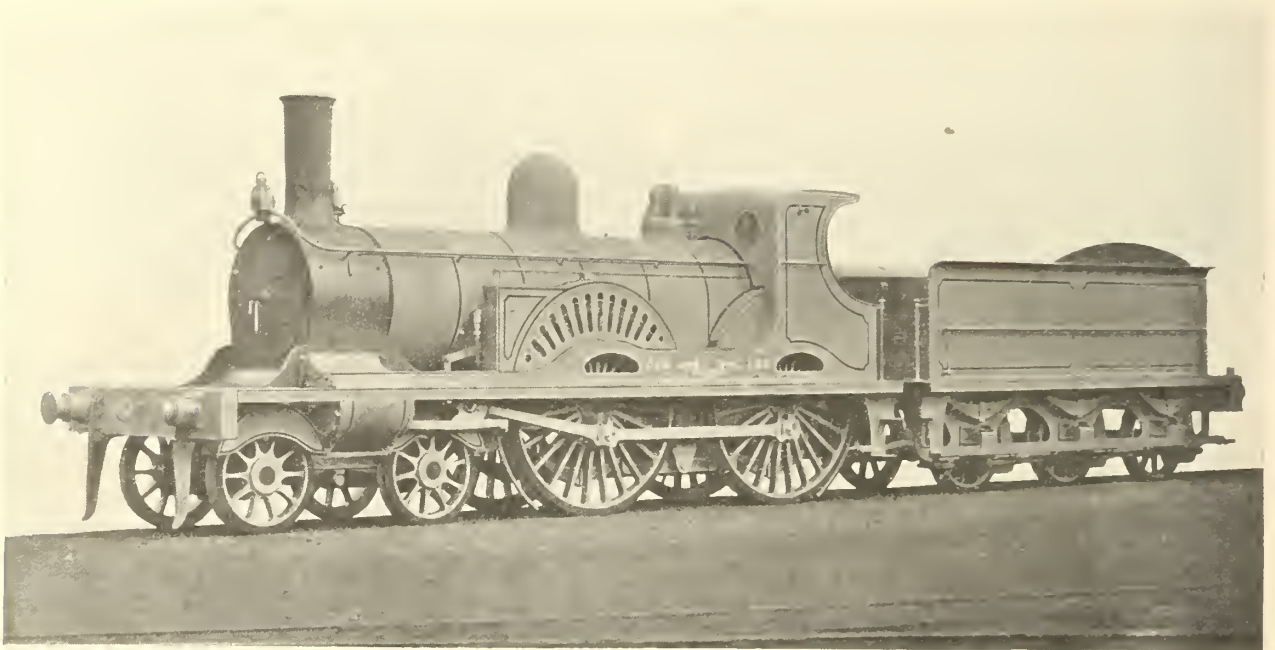

FIG. 280—BRITTAİN'S 4-4-0 PASSENGER ENGINE, CALEDONIAN RAILWAY, 1877

2½in.; fire-box heating surface, 82 square feet; total, 987 square feet; grate, 14.6 square feet; pressure, 130 lb.; weight in working order, 41 tons 7 cwt. These engines had ordinary slide valves inside working on vertical port faces, and Gooch's stationary link motion. They were originally intended to replace the 8ft. 2in. single engines on the main line north of Carlisle, but the boilers were much too small, with the result that the old singles could tackle trains which the new engines could hardly "look at." After some years of secondary work in the Dundee district they were reboilered in 1887 by D. Drummond, and made into more serviceable engines.

It is a remarkable fact that many of the 4-4-0 engines with outside cylinders built during this period were not very successful, and amongst the category must be included W. Adams's first 4-4-0

engines of 1876-77 for the Great Eastern Railway, which had 18in. by 26in. cylinders, 6ft. 1in. coupled wheels, 1109 square feet of heating surface, 140 lb. pressure, and weighed no less than 45 tons 1½ cwt.—Fig. 281. These engines, though intended for heavy main line passenger trains, had to be relegated to fast goods service.

In all the above-mentioned engines the position of the cylinders had only an indirect effect in causing the trouble, which was really due to an epidemic of large cylinders and small boilers. The permissible weight was taken up by the framing and motion to the neglect of the boilers, which were starved. The outside cylinders required thick frames, since Yorkshire iron and not steel was the material used, and the thickness was generally at

least 1½in. thick. W. G. Beattie in his unfortunate engines had to use thinner frames, and they cracked in service, causing another trouble. Adams's Great Eastern engines were stated to have been too heavy.

W. Adams, in his later designs of 1880-87 for the London and South-Western Railway, seems to have had greater latitude than Beattie in the permissible weights, and then produced an excellent engine. This type is shown in Fig. 282, which shows an engine by Beyer, Peacock and Co., 1880. Others were built in 1883-87 by Stephenson and by Neilson. The cylinders, 18in. by 24in., were of reasonable size, but the pressure was increased to 160 lb. The Yorkshire iron frames were 1½in. thick. The other dimensions were as follows:—Coupled wheels, 6ft. 7in.; bogie wheels, 3ft. 4in.; wheel base, 7ft. + 6ft. 5½in. +

8ft. 6in. = 21ft. 11½in.; heating surface of fire-box, 111 square feet; total, 1223 square feet; grate, 17¾ square feet. Weight in working order: bogie, 16 tons 11 cwt.; driving, 15 tons; trailing, 15 tons 4 cwt.; total, 46 tons 15 cwt. The engines built in 1884 had the heating surface reduced to

added that after more than thirty years' service there was hardly a rivet in any part of the twelve engines by Beyer, Peacock which had become loose. The writer can testify to the very high speeds which the Stephenson-built engines, with 7ft. wheels, frequently attained.

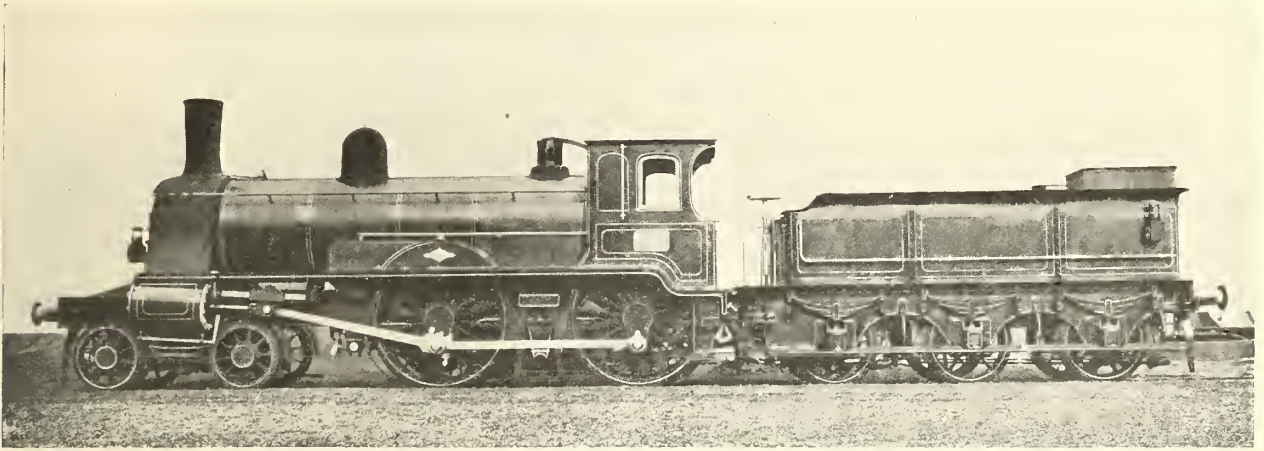

FIG. 281—W. ADAMS'S 4-4-0 ENGINE, GREAT EASTERN RAILWAY, 1876

1161½ square feet. Twelve similar engines, by R. Stephenson and Co., had 7ft. 1in. coupled wheels. All had compensating levers connecting the springs of the coupled wheels; after 1880 Adams was almost the only British engineer who retained these levers, but his engines, unlike those mentioned previously in this connection, had bogies, and therefore three-point suspension. Their weight may be noticed; they were the

Engines of the 0-4-2 Type.—In 1876 W. Stroudley introduced the 0-4-2 type for passenger service. The earlier engines were in reality "mixed traffics," somewhat similar to those of P. Stirling on the G.N.R., and had 5ft. 6in. wheels with 17in. by 24in. cylinders. But in 1878-80 six express engines were built at Brighton works with large 6ft. 6in. front coupled wheels and 17½in. by 26 in. cylinders. They are not

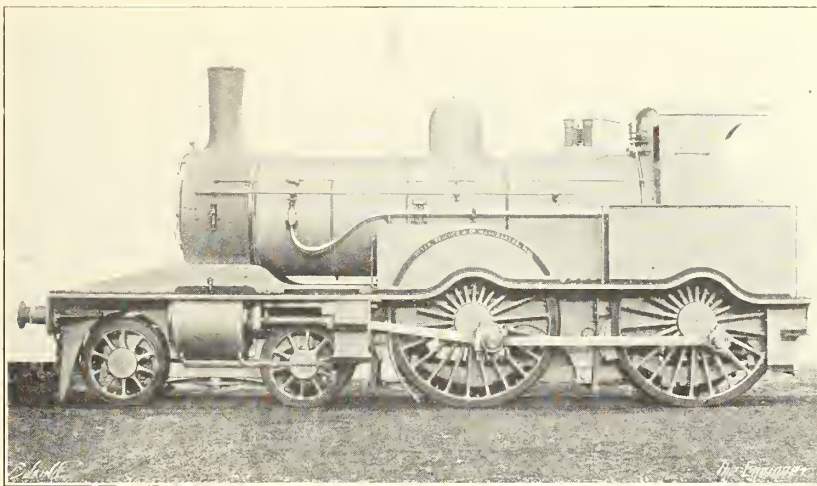

FIG. 282—W. ADAMS'S 4-4-0 LONDON & SOUTH-WESTERN RLY. ENGINE, 1889

heaviest express engines then running in this country.

As a testimony to the excellent workmanship for which British firms are celebrated, it may be

illustrated, since they were very similar to the larger engines of 1882, the celebrated "Gladstone" class, which are described in due course. It may, however, be noted here that

Stroudley was not the first to use large coupled leading wheels for express engines. In 1873 E. Kessler, of Esslingen, constructed 0-4-2 express engines for an Austrian railway with front coupled wheels 6ft. 2 $\frac{3}{4}$ in. diameter.

Main Line and Express Passenger Tank Engines.—In 1877 the Lancashire and Yorkshire Railway introduced the 0-4-4 side tank engines—Fig. 283—for main line fast trains from Manchester to Leeds, Hellifield and Blackpool. The general design was due to W. Barton Wright, but the details were the work of Kitson and Co., who built the first two engines. They had longer side tanks, but the road in those days limited the weight allowance, and in the later engines of 1878-79 by Kitson, Dübs and Neilson, the tanks were shortened, as shown in the illustration. The cylinders were 17 $\frac{1}{2}$ in. by 26in.; coupled wheels, 5ft. 8in.; bogie wheels, 3ft. 1 $\frac{1}{2}$ in. diameter; rigid wheel base, 7ft. 7in.; total, 22ft. 11in.; total heating surface, 1057 square feet; grate, 17 square feet; pressure, 140 lb.; weight full: leading, 13

engines, the length of main line operated to Penzance being about 111 miles. It was therefore decided to try tank engines on the standard gauge sections between Wolverhampton and Oxford, *via* Worcester, and also on the main line from Wolverhampton to Shrewsbury. Three 2-4-0 engines were built at Wolverhampton, the outside frames at the front end being taken from some older engines by Beyer, Peacock. The cylinders were 17in. by 24in.; coupled wheels, 6ft. diameter; wheel base, 17ft., equally divided; total heating surface, 1297 square feet; of which the fire-box provided 99 square feet; pressure, 140 lb.; tank capacity, 1000 gallons. These engines proved to be somewhat too heavy, and after about three years' service they were converted to tender engines, when the wheel base between the leading and driving wheels was shortened by 6in.

Three 4-4-0 side tank engines were designed by D. Drummond and built in 1879 by Neilson for the fast traffic of the North British Railway between Glasgow and the coast, north of the

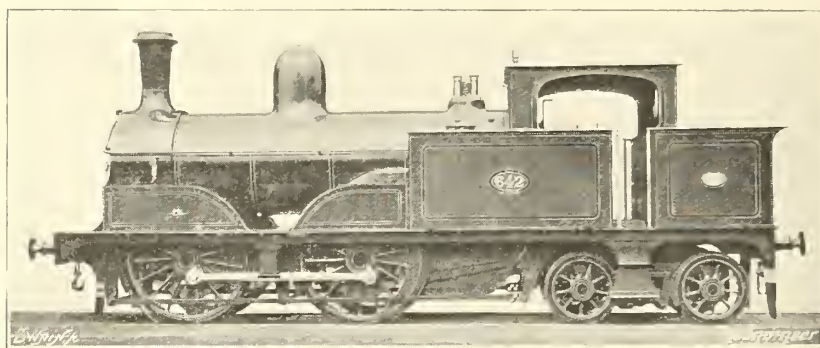

FIG. 283—W. B. WRIGHT'S LANCASHIRE & YORKSHIRE RLY. TANK ENGINE, 1878-86

tons 15 $\frac{3}{4}$ cwt.; driving, 15 tons 2 $\frac{1}{2}$ cwt.; bogie, 20 tons 13 $\frac{3}{4}$ cwt.; total, 49 tons 12 cwt.; capacity of side and back tanks, 1110 gallons.

One of the reasons for the use of express tank engines on the L. and Y.R. was the short length of many turntables. As these were gradually reconstructed, 4-4-0 tender engines replaced the tank engines, and the latter were then devoted to local train services, on which they did very good work. In their "express" days they always appeared to do well, though the start to stop speeds of the best L. and Y.R. trains of that time, about 33 to 36 miles per hour, were low. The engines suffered from lack of water capacity, for main line work, but that was the product of unavoidable circumstances.

In 1879-81 the Great Western took up the express tank engine, though for different reasons, chief amongst which was the economy in dispensing with tenders. From the earliest days of the South Devon and Cornwall railways (7ft. gauge), all trains west of Newton Abbot had been worked by the old Gooch type of 4-4-0 saddle tank

Clyde. Cylinders, 17in. by 26in.; diameter of coupled wheels, 6ft., with centres 8ft. apart; total wheel base 21ft. 1in.; pressure, 150 lb. This type of engine does not lend itself to large tank capacity, and the water carried amounted only to 950 gallons. These three engines were in service until 1924, but the class was never repeated. Drawings may be found in *The Engineer*, May 23rd, 1879.

Drummond's tank engines for the North British local traffic were of a similar 4-4-0 type, but much smaller, having 5ft. coupled wheels and 16in. by 22in. cylinders. The bogie wheels had solid disc centres. When Drummond went to the Caledonian Railway in 1883 he discarded the type for the 0-4-4 wheel arrangement.

It was a private firm of locomotive builders—Sharp, Stewart and Co., then of Manchester—which solved the problem of the main line tank engine, and in 1880 designed and built the first of the 4-4-2 type. These engines—Fig. 284—were the well-known "universal" engines of the London, Tilbury and Southend Railway, used for

all classes of traffic, including the express trains. By adding a radial trailing axle part of the water could be carried at the back, and a larger coal bunker was also obtained. The tanks held 1300 gallons, and the coal bunker 40 cwt. The cylinders were horizontal, 17in. by 26in., and placed outside; coupled wheels, 6ft. 1in. diameter; bogie and trailing wheels, 3ft. 1in. diameter; wheel base, 6ft. 6in. + 7ft. 1in. + 8ft. 6in. + 7ft. 3in. = 29ft. 4in.; total heating surface, 1020 square feet; grate, $17\frac{1}{4}$ square feet; pressure, 160 lb.; weight in working order: bogie, 15 tons 18 cwt.; driving, 16 tons $1\frac{1}{2}$ cwt.; coupled, 16 tons $0\frac{1}{2}$ cwt.; trailing, 8 tons $2\frac{3}{4}$ cwt.; total, 56 tons $2\frac{3}{4}$ cwt. The slide bars were single; the trailing radial axle was not of the Webb type, but of a modified Adams type with spring control.

One extraordinary Great Western express tank engine, of which hardly anything is known, remains to be mentioned as a historical curiosity, though in its original form it did no actual service. This was a standard gauge 4-2-4 side

with the valves on the top, driven by Stephenson's link motion; but to render the gear accessible the excentrics and valve gear were placed outside the driving wheels, and motion was communicated to the valves by means of a rocking shaft. The tanks were cut away to clear this motion. The water was carried partly in two extremely long side tanks, which extended for a short distance beyond the front of the smoke-box. Part of the water was also carried in a large bunker tank at the back, the total water capacity being 2535 gallons. The total length of the platforms was 36ft. 5 $\frac{1}{2}$ in. The sand-boxes were built into the structure of the upper part of the tanks, immediately in front of and behind the driving wheels, and were filled from above the tanks. The boiler was of considerable length and without a dome, but the dimensions are not known. The engine might have succeeded on the straight main line, but left the road in negotiating the engine shed sidings, the bogies being at fault. It has to be remembered that designs for bogies were by no means stabi-

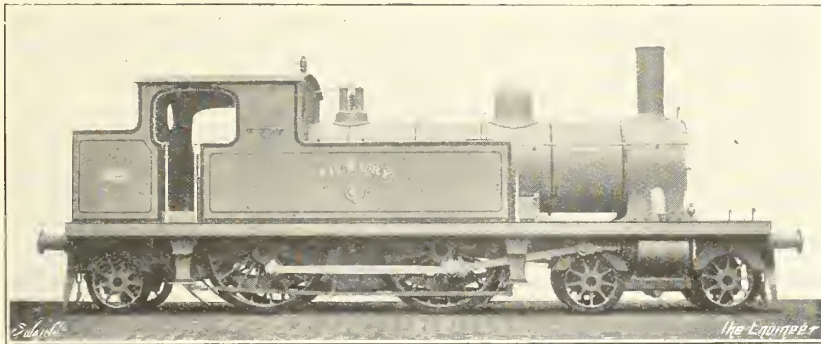

FIG. 284—SHARP, STEWART'S LONDON, TILBURY & SOUTHIEND RLY. ENGINE, 1880

tank locomotive, somewhat on the lines of Pearson's celebrated Bristol and Exeter tank engines, and was an experiment on the part of William Dean, who built it at Swindon in 1881. The only drawing which can be found is that of the side tanks, of which Mr. C. B. Collett has kindly sent the writer a copy. But the writer heard a description of the engine at Swindon, and also found some parts of it himself, and from these sources and the drawing, which gives several leading dimensions, the following particulars are added. Each end was carried on a bogie, which had wooden wheel centres of the Mansell carriage wheel pattern. Whether the bogie pins had lateral movement is very doubtful; the Great Western practice of that day in the matter of bogies was somewhat antiquated. The front bogie had a wheel base of 7ft. 3in., that of the trailing bogie being 5ft. 6in. A pair of single driving wheels, 7ft. 8in. diameter, with inside bearings only, was placed between the two bogies, the wheel base being 7ft. 3in. + 6ft. 6in. + 10ft. 9in. + 5ft. 6in. = 30ft. The cylinders, 18in. by 26in., were inside,

James Stirling until 1882 used rigid centre pivot bogies, and T. N. Ely, the superintendent of motive power on the Pennsylvania R.R., was so far from satisfied with the behaviour of bogies with lateral movement of the pivot that he modified those under his charge and converted them to the rigid centre pin type. The G.W.R. tank engine was subsequently completely reconstructed as a 2-2-2 engine, to be mentioned in a following chapter.

There was, between 1880 and 1889, a cry for economy, and to this end many experiments, including compounding, were tried on different railways, with the approval of the directors. Mr. Dean was trying to save the expense of tenders, and in his large tank engine was forced to use bogies.

Four-wheels Coupled Passenger Tank Engines for Local Traffic.—In 1876 F. W. Webb built at Crewe a number of 2-4-0 side tank engines with inside cylinders and bearings, the chief feature of which was the first application of his well-known radial axle-boxes for the leading wheels.

These are referred to subsequently. The cylinders were 17in. by 20in.; the coupled wheels were 4ft. 7½in. diameter; the total heating surface was 971.6 square feet; grate, 14.24 square feet; pressure, 140 lb.; tank capacity, 900 gallons; weight, 35¾ tons in normal working order. The water and fuel capacities were not sufficient for all services, and in 1880 an enlargement of the engines was made by the addition of a radial axle under the trailing end, thus producing the now well-known 2-4-2 type. One of the latter engines is shown in Fig. 285. The wheel base was

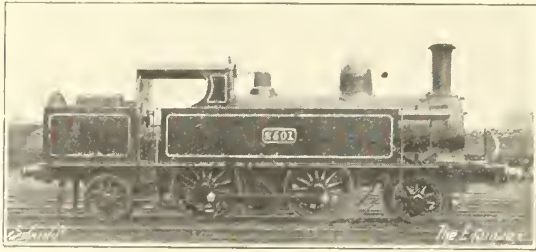

[Photo. Locomotive

FIG 285—F. W. WEBB'S TANK ENGINE, L. & N.W.R., 1880-90

6ft. 9in. + 7ft. 9in. + 6ft. 9in. = 21ft. 3in.; tank capacity, 1450 gallons; weight in working order: leading, 10 tons 1 cwt.; driving, 13 tons 10 cwt.; coupled, 13 tons 6 cwt.; trailing, 9 tons 1 cwt.; total, 45 tons 18 cwt.

In the 2-4-0 engines of 1876 steel frames were used, though whether this was the first application of steel for this purpose the writer cannot say definitely, but he thinks that the credit for using this material for frames in this country is due to F. W. Webb. The engines were fitted with an hydraulic brake, the cylinder of which was 9in. diameter by 9in. stroke, the piston being forced upwards by water from the boiler under full pressure. The arrangement was controlled by a three-way cock, and the piston was kept down, when the brake was off, by steam from the boiler. By moving the handle of the cock the boiler steam was cut off and that in the cylinder allowed to escape into the tanks, whilst at the same time the water from the boiler was forced into the bottom and applied the brake.

Webb, who at that time had a liking for small driving wheels, tried one of the 2-4-2 tank engines on express trains between Manchester and Leeds, but at the end of a week it was taken off. Wheels 4ft. 7in. diameter are somewhat too small for fast trains. Another of the class was lent to the Caledonian Railway, on which it was tried on the Callander and Oban line. It appeared to behave satisfactorily, and as a result, the Caledonian Railway, in 1880, designed a double radial 2-4-2 tank engine for the same service. These engines had Webb's radial axles, and the cylinders were outside. But at high speeds they proved extremely unsteady, and, after the leading radial axles had been blocked to run as rigid axles, they were

relegated to slow local trains in the Glasgow district. They had 17½in. by 22in. cylinders and 5ft. 8in. coupled wheels; wheel base, 6ft. 6in. + 8ft. + 6ft. 6in. = 21ft.; weight, 52 tons 12 cwt., of which 34½ tons were on the coupled wheels.

W. Adams, on the L. and S.W.R., designed a 4-4-0 tank engine, twelve of which were built in 1878-79 by Beyer, Peacock and Co. Cylinders, 18in. by 24in.; coupled wheels, 5ft. 7in. diameter; the bogie wheels were very small, only 2ft. 6in. diameter, with solid disc centres, and were placed 6ft. 6in. apart; the coupled wheels were 8ft. 6in. between centres; total base, 21ft. 8½in.; total heating surface, 1047 square feet. The cab roof was carried too far back, and the engines had to be coaled from the inside; they were subsequently altered to 4-4-2 engines, with the addition of trailing radial axles, larger coal bunkers, and increased water space. In their original 4-4-0 condition they weighed about 52 tons in working order.

Six Wheels Coupled Passenger Tank Engines.—The 0-6-2 tank engine with trailing radial axles, now to be found on most British and many Dominion railways, made its first appearance on the Lancashire and Yorkshire Railway in December, 1879, when W. Barton Wright rebuilt an old goods engine with side tanks, and to obtain sufficiently large tanks and bunker added a Webb radial axle at the back. Barton Wright's new type was adopted by Webb in 1881 at Crewe.

The later and larger 0-6-2 tank engines of the L. and Y. Railway, built by Kitson in 1881 and Dübs in 1882, are shown in Fig. 286. The engine illustrated—No. 253—was sent by Kitson and Co. to the 1881 Stephenson Centenary celebration. The class, which consisted of 54 engines, was intended for heavy passenger work in the Manchester, Oldham, and Rochdale district, on which



FIG. 286—W. B. WRIGHT'S L. & Y. RLY. TANK ENGINE, 1881

the gradients are exceptionally heavy. The cylinders were 17½in. by 26in.; coupled wheels, 5ft. 1in.; radial wheels, 3ft. 7¾in. diameter; wheel base, 7ft. 3in. + 6ft. 8in. + 6ft. = 19ft. 11in.; total heating surface, 1021 square feet, of which the fire-box provided 85½ square feet; pressure, 140 lb.; weight in working order, 49 tons 7 cwt., of which the radial axle carried 9½ tons. The tank capacity was 1200 gallons.

The main purpose of the 0-6-2 design was to

provide additional coal and water space. It has sometimes been stated that the radial trailing axle improves the curving property of the engine. This is the case only when the engine is running bunker first and the radial axle leads, but when running chimney first it is frequently detrimental, since the controlling force at the trailing end levers the front of the engine outwards, and adds to the flange pressure of the outer leading wheels on a curve. There have been cases of 0-6-2 tank engines, which were not satisfactory on roads with severe curves, on which they had to be replaced by 0-6-0 tank engines.

Goods Engines—0-6-0 Type.—A few characteristic and notable engines of the 1876-81 period may be briefly mentioned.

One of them is S. W. Johnson's express goods engines for the Midland Railway which first appeared in 1878, when Dübs built twenty—Nos. 1357 to 1376—Fig. 287. The "express" goods

performances of Midland Rly. engines 1357 to 1376 were on a par with their "finish." Most of them were stationed at Manningham (Bradford), and amongst other duties worked the fast express goods and wool trains between that place and London at average booked speeds of about 35 miles per hour. There were four of them on these trains each night, two up and two down, the mean distance being about 200 miles. The drivers were exceedingly proud of them, and had to record very few entries against them in the shed repairs book. They also worked a large number of fast excursion trains. Thirty similar engines were built by R. Stephenson and Co., 1880-81, one of which the firm sent to the Stephenson Centenary. The total heating surface of these locomotives was 1223 square feet, and they were built to carry 150 lb. pressure. A number of them did very good work from the London end.

Some North-Eastern express goods engines by



FIG. 287—S. W. JOHNSON'S GOODS ENGINE, MIDLAND RAILWAY. 1878

[Photo. Locomotive

engines had larger wheels, 5ft. 2½in. diameter, than those previously used in Johnson's Midland engines, which were 4ft. 10in. They were the first engines on the line to have steam brakes. The cylinders were 17½in. by 26in.; wheel base, 8ft. + 8ft. 6in.; fire-box heating surface, 110 square feet; total, 1313 square feet; grate, 17½ square feet; pressure, 140 lb.; total weight in working order, about 37 tons 18 cwt.

In their day they were probably the best express goods engines in the country, and they were most beautifully finished. It has been suggested that "finish" is not a commercial proposition. This may be so to-day, when less "fitting" is done than formerly and essential dimensions are machined to gauges and there is less hand work. But it was not the case formerly, when good "finish" invariably meant that excellent workmanship had been put into the engines. Certainly

E. Fletcher, of which eleven were built at Darlington, 1880-82, had large wheels 5ft. 8in. diameter and 17in. by 26in. cylinders—Fig. 288. They were employed on the East Coast express goods trains between York and Newcastle, and also on heavy excursion trains, for which they were fitted with the Westinghouse brake. The wheel base was 16ft. 6in.; pressure, 140 lb.; weight, about 36 tons. One of these engines was sent by the company to the Stephenson Centenary.

The L. and N.W.R. engine—Fig. 289—the first of which was built at Crewe in 1880 to F. W. Webb's designs, is of interest in that it was the earliest main line engine in this country to have Joy's valve gear. Other new features were the ashpan with water bottom, and the now well-known fire-hole without the solid ring, the design of which appeared a year or two previously; these details are mentioned later. The cylin-

ders were 18in. by 24in., with valves on the top, the latter being of the Trick type, with internal passage. The wheels, 5ft. 1½in. diameter, were of cast iron in the first ten engines of 1880-83, but in subsequent engines, from 1887 onwards, cast

and Lincolnshire Railway, of which sixty-two were built at Gorton Works. They were of the double-framed type, with very solid outside plate frames, to which reference is made in a subsequent chapter. Cylinders, 17½in. by 26in.;

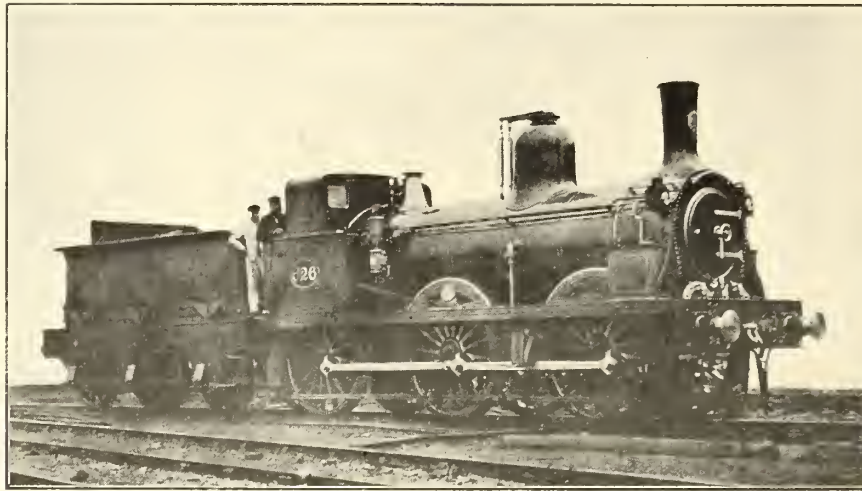

[Photo. Locomotive

FIG. 288—E. FLETCHER'S EXPRESS GOODS ENGINE, NORTH-EASTERN RLY., 1880-82

iron was discarded. Wheel base, 7ft. 3in. + 8 ft.3in. ; boiler in two rings of $1\frac{13}{32}$ in. steel plates, 4ft. 2in. diameter outside the larger ring; heating surface of fire-box, 94.6 square feet; total, 1079.8 square feet; grate, 17.1 square feet; pressure, 140 lb.; total weight, 33 tons 7 cwt. The *smoke-box* tube plate was of copper in the earlier engines. The two lengths of coupling-rod were jointed together on the outside crank pin as in J. F. Stephenson's method—Fig. 269 *ante*. The inside crank pins were 5½in. long by 7¾in. diameter, the unusual length being made possible by the absence of eccentrics, and the placing of the cylinder centres only 1ft. 10in. apart. The crank webs were 5in. wide on the inside and 4¾in. on the outside of the big end. The trailing end was

diameter of wheels, 4ft. 9in.; wheel base, 15ft. 2in.; diameter of boiler, 4ft. 5in.; fire-box heating surface, 87.5 square feet; total, 1229 square feet; grate, 18¼ square feet; weight in working order, about 40 tons. The pressure was only 130 lb., the standard in nearly all Sacré's engines, except those of the 4-4-0 type previously described, and the later "singles."

A Great Western goods engine which had the appearance of the usual type of single-framed engine must be mentioned. In reality it was one of J. Armstrong's standard double-framed engines of 1875-76, which was built as a broad—7ft.—gauge engine by placing the wheels outside the outer frames, and providing new axles. In 1885 to 1891, when the impending doom of the broad gauge was foreshadowed, a considerable number of standard gauge engines were converted to the 7ft. gauge in a similar manner, and when the final abolition of the broad gauge took place in May, 1892, they were easily re-converted, after which they appeared as double-framed engines with outside coupling-rod cranks. These engines had 5ft. wheels, 17in. by 24in. cylinders, 1212 square feet of heating surface and 140 lb. pressure.

Goods Engines, 2-6-0 Type.—For the first time in the history of British railways, the "Mogul," or 2-6-0, goods engine with leading pony truck, made its appearance in 1878, when fifteen engines—Fig. 291—were built by Neilson for the Great Eastern Railway. The general design was made by W. Adams before he left Stratford for the London and South-Western Railway, but modifications in the details embodying various

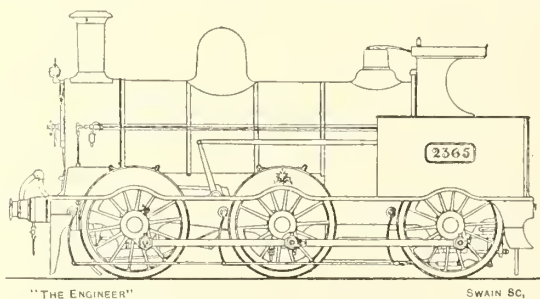

FIG. 289—E. W. WEBB'S L. & N.W.R. GOODS ENGINE, 1880

carried on a transverse spring. These became the standard main line goods engines, and 310 were constructed up to 1902.

Fig. 290 shows Charles Sacré's heavy goods engines of 1880-85 for the Manchester, Sheffield

American features were made by his successor, Massey Bromley. The slide valves were above the cylinders, and of Webb's circular pattern. They were worked by inside Stephenson motion

connected to three-point T-headed links, the two upper pins of which bore on a transverse frame connecting the axle-boxes, and controlled the lateral movement. This pony truck was a copy of

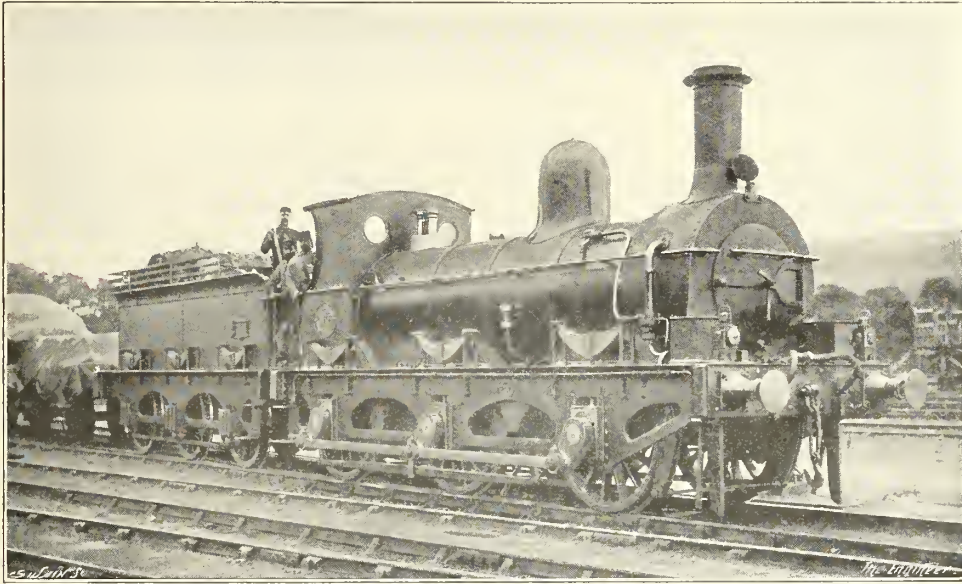

FIG. 290—C. SACRE'S M.S. AND L.R. HEAVY GOODS ENGINE, 1880-85 (Photo. Locomotive)

through a rocking shaft, seen in the illustration immediately behind the smoke-box. Single slide bars, introduced by Adams on the G.E.R., but derived from the practice of Dübs and Co., were used. The pony truck was of somewhat complicated construction, which it would be impossible to describe clearly without drawings. Those interested will find plans in *Engineering*, January

one then in use on the Pennsylvania Railroad. The driving tires were originally flangeless, but were soon afterwards replaced by flanged tires. The first five engines had additional sand-boxes on the boiler, as shown, after Adams's North London practice, but they were also removed after a few months' service. Steam brakes were also provided. The cylinders were 19in. by 26in.; coupled wheels,

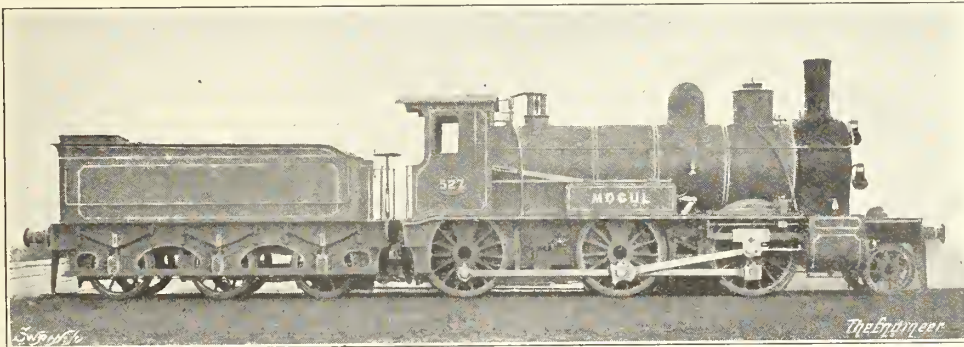

FIG. 291—M. BROMLEY'S GREAT EASTERN RAILWAY GOODS ENGINE, 1878

23rd, 1880. Suffice it to say that the weight was transferred by a system of beams to a hollow cylindrical plunger resting on a rubber pad lying in a cradle immediately above the truck axle. Instead of a swing beam, there were two transverse laminated springs. The ends of the latter were

4ft. 10in.; truck wheels, 2ft. 10in. diameter; wheel base, 7ft. 5in. + 7ft. 3in. + 8ft. 6in. = 23ft. 2in. The boiler barrel, 11ft. 5in. long by 4ft. 6½in. outside diameter, contained 240 1¾in. tubes; fire-box heating surface, 102 square feet; total, 1393 square feet; grate, 17.8 square feet;

pressure, 140 lb.; weight in working order, truck 8 tons 10 cwt., leading coupled 12 tons 11 cwt., driving 13 tons, trailing 12 tons 11 cwt., total 46 tons 12 cwt.

These engines were by no means a success. They were intended for heavy coal traffic between London and Peterborough, *via* March, but did not steam well, and were extremely heavy on coal and oil. The older Johnson 0-6-0 engines, which had worked this traffic, though much less powerful and less capable of hauling such heavy loads, were much more economical *pro rata*. The result was that at the end of a service lasting only six to eight years the "Moguls" were broken up. Possibly as a result of this experience, the G.E.R. for more than twenty-one years afterwards always employed comparatively small 0-6-0 engines, with 17½ in. by 24 in. cylinders.

In connection with engines of the "Mogul"

foreman was not provided with any diagram or instructions, and the firm which had built the engine had then changed hands. The engine was sent in January, 1882, to the works of another railway, where the Walschaerts gear was also completely strange. A valve card of that date, a copy of which the writer possesses, shows that instead of having a constant lead in all positions of the reversing gear, the front lead in fore gear varied from $\frac{3}{16}$ in. in full gear to $\frac{1}{4}$ in. bare when notched up. There were corresponding differences in the back leads, from $\frac{5}{16}$ in. to $\frac{9}{32}$ in., and similar variations when running in back gear. The engine proved to be a veritable white elephant, and consumed more than 40 lb. of coal per mile on light passenger trains of about six small carriages. It consequently spent most of its time in a siding, and was used only in emergencies. The cylinders were 16 in. by 22 in.; wheels,



FIG. 292—SINGLE FAIRLIE TANK ENGINE, SWINDON, MARLBOROUGH & ANDOVER RAILWAY, 1878

and other types not usual on British railways, it should be pointed out that such engines had already been constructed in considerable numbers by the private locomotive builders for overseas.

Single Fairlie Passenger Tank Engine, with Walschaerts Valve Gear.—In 1878 a 0-4-4 side tank engine, designed by the Fairlie Engine Company, London, and built by the Avonside Engine Company, of Bristol, was exhibited at Paris. In 1881 it, or an exactly similar engine—Fig. 292—was bought by the Swindon, Marlborough and Andover Railway. Like McDonnell's two Great Southern and Western tank engines it had one steam bogie in front and an ordinary bogie behind, but differed from the Irish engines in that the cylinders were outside. Its chief historical claim is that it was the first locomotive on any British railway with Walschaerts valve gear. Unfortunately, the shed

5ft. 6in. and 4ft. diameter; coupled wheel base, 6ft. 6in.; trailing bogie base, 6ft.; distance between bogie pivots, 15ft. 4in.; tank capacity, 1200 gallons; weight in working order, 44 tons.

The Walschaerts valve gear did not reappear on a British railway until a good many years later, when Beyer, Peacock introduced it on the Belfast and Northern Counties Railway. But all the private locomotive building firms had long constructed engines fitted with it for overseas railways.

Small Shunting Engine.—A special type of four-wheeled yard shunting engine—Fig. 293—was designed for the L. and N.W.R. by F. W. Webb, and ten were built at Crewe, 1880-82. The driver stood at one end and the fireman at the other, so that either could couple up the wagons. The brake and reversing gear could be operated from either end. The furnace and casing were

[Photo. Locomotive

semi-circular at the top and bottom, with stayed flat sides. The furnace was 2ft. 6in. long, with a water-tube grate similar to that previously described. A combustion chamber extended into the barrel, and at the front end were 120 $1\frac{3}{4}$ in.

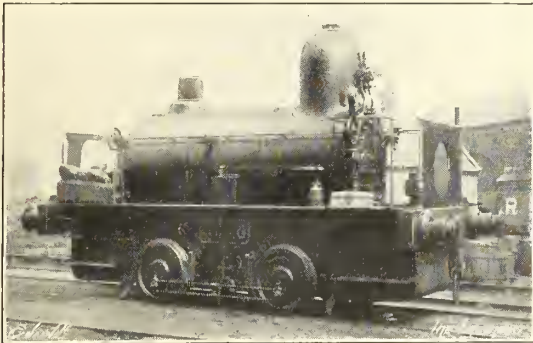

FIG. 293—F. W. WEBB'S L. & N.W.R. SHUNTING ENGINE, 1880-82

tubes, only 3ft. 6in. long. The smoke-box was inside the boiler, and surrounded by water. The chimney passed through the dome, and was supposed to help in drying the steam. The $\frac{1}{2}$ in. steel frames formed the sides of the tanks. Allan's straight link was used. The coupling-rods were formed of two light rods in a stay between them at the centre. This design without the stay had frequently been used in early German locomotives about 1847-48. The cylinders were 9in. by 12in.; wheels, 2ft. 6in.; wheel base, 5ft. 6in. The total heating surface, which was estimated to include the smoke-box and chimney surface, was 257.8 square feet; tanks, 260 gallons; weight in working order, 15 tons 3 cwt.; weight empty, 13 tons. The arrangement of using the frames as the tank sides was first introduced by Sinclair on the Caledonian Railway in 1849. It was revived many years later by Krauss and Co., of Munich.

DETAILS.

Radial Axle-boxes.—A large proportion of the new details introduced or tried during this period were due to F. W. Webb, who was a veritable mechanical genius in respect of bold designs. Some of his detailed improvements were excellent, and have become standard practice; others were of very doubtful utility. Amongst the former are the Webb radial axle-boxes, the first of which was applied to the leading axle of a 2-4-0 tank engine in 1876. This early arrangement is shown in Fig. 294 in plan. Webb took the old Bridges Adams radial-boxes of 1863, which were independent of each other on the two sides of the engine, except for the indirect connection through the axle, and joined the two (A A) together by a curved casting, from side to side of the engine, so that they moved in unison. The curved steel plates B B were bolted to the main frames, the width of space between

B B being $\frac{1}{2}$ in. greater than the width A A, so that no fitting was required. He also used William Adams's india-rubber bogie check springs S S. These were compressed between the centre stay D, uniting the plates B B and the stays E between the curved axle-box sides. The bolt through S S and D, which was secured by nuts outside E, is not shown in the figure. The above arrangement was not patented, and as Webb himself said, was free to all. It was not until 1882, after the Bottomley axle-box, mentioned on page 226, had appeared, that Webb took out a patent for the present type of axle-box. This differed from the one described in having a single spiral spring enclosed within a box, which replaced the stays E E.

The arc measured to the centre of Webb's axle-box of 1876 and subsequent designs was struck from a centre midway between the four coupled wheels. This radius was exactly twice that recommended by Bridges Adams, and more than twice that derived from Baldry's rule—Fig. 208 *ante*. It would be interesting to know why this dimension was adopted. It is true that with a long radius the flange of the leading radial wheel is maintained in position against the outer rail on a curve, and "hunting" of the radial axle is lessened, but this fact does not appear to have been recognised until some years later. The old St. Helens 2-4-2 engine "White Raven"—Fig. 195 *ante*—was notoriously unsteady; the curve of its axle-boxes was struck from the centre of the next coupled axle, but the main cause of the trouble was the absence of check springs. But on another railway on which Webb's axle-boxes were used in 1881, on 2-4-2 tank engines, the latter were very unsteady, although provided with check springs and with the length of radius in accordance with Webb's rule. They were afterwards somewhat improved by choking the movement of one of the radial axles. Nevertheless, Webb's axles have

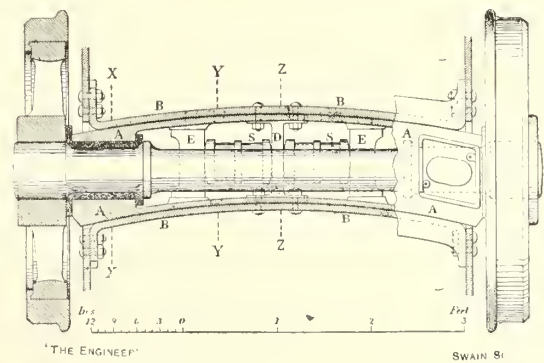

FIG. 294—F. W. WEBB'S RADIAL AXLE-BOX, 1876

done very good service for local tank engines running at moderate speeds.

The trailing radial axle-boxes of Sharp,

Stewart's 4-4-2 tank engines for the London, Tilbury and Southend Railway of 1880 differed from Webb's original design in that Timmis's spiral steel springs were used instead of india-rubber, and that the curved guides were limited to the surfaces between the axle-boxes and horn-cheeks. The two axle-boxes were connected across the engine by a straight casting. The radius of

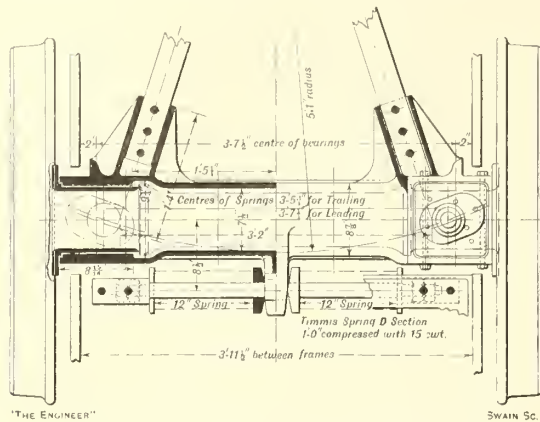

FIG. 295—BOTTOMLEY'S RADIAL AXLE-BOX, 1881

curvature was very nearly equal to that given by Baldry's rule, and therefore much less than that of Webb.

The Bottomley radial axle—Fig. 295—patented in 1881 and introduced by Sharp, Stewart and Co., is really an improved Bissel truck, in that curved axle-box guides are not used. The two axle-boxes are made in one piece jointed together, so that the axle is enclosed within a long straight box. To each end of the box the sides of a triangular frame, which form the radius bars, are solidly attached, and the whole pivots about a central pin placed at a suitable distance from the axle. The bearing springs, as in Adams's design, rest on shoes on the axle-box. The lateral control is given by spiral check springs, and the movement is limited by stops. This simple form of truck has been largely adopted; the 4-4-2 tank engines by H. A. Ivatt for the Great Northern Railway are similar in principle with it, as also are the large 4-4-2 tank engines of the Brighton Railway.

For ordinary axle-boxes, F. W. Webb made the bearings of his goods engines $\frac{1}{4}$ in. larger in diameter than those of his passenger engines, so that the axle-boxes of the latter, when worn, could be re-bored to suit the goods engines. The distance between the axle-box guides in the goods engines was $\frac{1}{4}$ in. less than in the passenger engines, to allow axle-boxes of the latter to be planed outside, when worn, to suit the former. The boxes were of cast iron, with the brasses cast in, a system which had been introduced by A. McDonnell in Ireland.

Valves and Valve Gear.—The slide valve—Fig.

296—was designed by F. W. Webb in 1869, though not used until some years later. The valve was circular and free to revolve in its buckle, so that if it had seized on any part of the surface it revolved and brought another portion to bear. The object was to avoid grooves and unequal wear. The valves C were turned in the lathe on the faces, steam and exhaust port edges, and where the buckle fitted, and the port edges were also circular. The buckle had sufficient play to allow for expansion. The clearances E and F in the port facing were arranged so that during the revolution of the valve in the buckle every portion of the valve face passed over them, and afforded means for lubrication. These valves were fitted to a number of engines on the L. and N.W.R., and also to the 4-2-2 and 2-6-0 engines by Massey Bromley for the G.E.R., but they quietly disappeared, and nothing further was heard of them. The writer has been told that the trouble on the G.E.R. was that the valves used to seize, the very fault which they were intended to obviate. Unless the lubrication were defective there is no apparent reason why seizure should have occurred, though it should be added that on the G.E.R. the valves were placed above the cylinders.

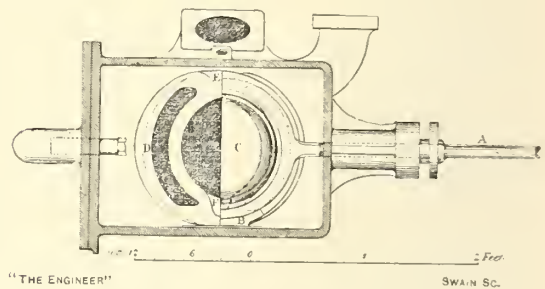

FIG. 296—F. W. WEBB'S CIRCULAR SLIDE VALVE, 1869

Joy's valve gear, invented in 1879, is so well known that it does not need description. The valves being above the cylinders, the latter, when inside, could be placed closer together, and eccentrics being absent, longer bearings could be used. The additional bearing surface enabled the engines to run a longer mileage between repairs, and this was the principal reason for the extensive adoption of the gear. The weak point is the hole in the connecting-rod, which, so long as the engines were of moderate size, did not cause a great amount of trouble. But with very large express engines, worked, as they now are, to the limit of their power, this weakness has lately been the cause of serious breakages.

It seems that Joy's gear was first tried experimentally in 1879 on an old four-wheeled Bury type goods engine of the Furness Railway, which had the steam chests above the cylinders, and was therefore suitable for the purpose. The first main line engine to have it was L. and N.W.R. engine 2365—Fig. 289—built at Crewe in June, 1880.

Boilers.—Webb's fire-box, in which the thick ring is discarded, and the casing and fire-box plates flanged and riveted directly together from the outside, is another clever detail which has been adopted very extensively, probably more so than any other of his numerous inventions. It has the advantage of keeping the joint away from the fire, and of not exposing a great thickness of metal to the heat. Some engineers object to it on the ground that the sharp angle between the two plates harbours deposit, which is difficult to clean out.

The "ashpan" with water bottom, which appeared in the goods engine of 1880, and was subsequently fitted to a large number of Crewe-built engines, was an addition of very dubious value. The fire-box foundation ring was suppressed, and the side and end water spaces carried downwards to connect with a similar full width water space which extended horizontally beneath the grate bars. In reality there was no separate ashpan, since the water bottom formed part of the boiler. At the front, between the bars and the water bottom, the full width of the fire-box casing, was a damper door, which opened inwards. The ashes were removed through a central hole in the bottom, the plates forming which, were flanged and riveted similarly to those forming the fire-hole. The principal idea of the design appears to have been a more elastic connection in place of the foundation ring, such as would eliminate the effects of repeated expansion and contraction, and also obviate the leakage at the ring. The dirt was also deposited in the water bottom below the level of the grate bars—a good feature in itself. But the claim that the circulation was improved is open to considerable doubt, since the cold water would

remain in the water bottom. This claim may have been an afterthought; not only does nothing seem to have been said about it when the design appeared in 1880, but the fire-box heating surface was estimated at exactly the same value as that of the otherwise similar fire-boxes with ordinary foundation rings and ashpans. The first series of thirty compound engines of 1882-84 had the water bottoms, for which no credit was given as heating surface.

Then, at the end of 1884, a funny thing happened, when the larger compounds of the "Dreadnought" class appeared, also with the same design. Somebody at Crewe suddenly discovered that as this water bottom below the grate was in direct connection with the side and end water spaces, it ought to be credited as fire-box heating surface, though how it assisted in this respect was not stated. Therefore, when the "Dreadnoughts" appeared, the total fire-box heating surface was officially given as 159 square feet, that is, about 35 to 40 square feet more than the real value, and the boiler power was thereby considerably enhanced—on paper. But this is not the whole story. Had the individual who discovered this extra heating surface gone underneath the engines on their arrival at the end of a long run in winter, he would have made the additional discovery that the outsides of the water bottoms were not infrequently thickly decorated with icicles, derived from the water troughs, a really sound testimony to the value of the extra "heating" surface! The design lasted for about ten years, after which a reversion was made to foundation rings of the usual pattern. No other locomotive superintendent tried Webb's design, as far as the writer is aware.

Chapter XVI

Train Resistances and Locomotive Performances, 1855-79

IT has been previously mentioned that very few records exist of actually observed train speeds and loads from about 1855 to 1875. The late Charles Rous-Marten made a number of observations about 1856, when he was very young, which, though in the main correct, occasionally, as he himself afterwards admitted, show the results of inexperience. Nevertheless, omitting a few doubtful runs, the majority give a valuable insight into locomotive performances of that day.

Comparative Train Resistances.—Before discussing these and other records something may be said on the subject of train resistance. D. K.

Clark's formulæ $R = 8 + \frac{v^2}{171}$ for total resistance per ton of engine, tender and train, and $R^1 = 6 + \frac{v^2}{240}$ for resistance per ton of train alone, were

derived from Sir D. Gooch's experiments with six-wheeled broad (7ft.) gauge coaches running on a longitudinal sleeper road. On pages 298 to 301 of "Railway Machinery," Clark recorded his own experiments on the Caledonian and Edinburgh and Glasgow railways on the 4ft. 8½in. gauge, but he seems to have been far from satisfied with the results. He stated—Chapter VII., page 300—that "the tonnage resistances on the 7ft. gauge are decidedly less than on the 4ft. 8½in. gauge. There are probably several causes for the difference, but the principal one is, in our mind, the superior permanent way on the Bristol and Exeter Railway, compared with that on the Caledonian, and Edinburgh and Glasgow lines—continuous longitudinal bearing *versus* interrupted transverse sleeper bearing; also the more perfect joints of the rails in contrast with the broken and yielding joints of the narrow-gauge rails. Then the narrow-gauge trials were made over lines with curves, whilst those of the broad gauge were made on a straight line."

Further on, when discussing the resistance recorded in the most reliable experiment on the Caledonian Railway, 40 per cent. greater than those given in Gooch's broad-gauge experiments, he added that "the excess is probably not exclusively due to the condition of the permanent way, but also, to a smaller extent, to the greater superficialities of the train per ton exposed to atmospheric resistance, and to the smaller wheels of the rolling stock. But the greater part of the excess is unquestionably due to the inferiority of the road." In the following chapter he wrote: "As our data are insufficient for the construction of narrow-gauge formulas, we shall meantime adopt our broad-gauge formulas as standard."

There is hardly any doubt that when Gooch made his experiments the longitudinal sleeper road was better than most of the contemporary transverse sleeper roads, more especially than those of the Scottish railways, on which Clark made his experiments; but in later years, from about 1875, when steel rails and better joints were used on the principal main lines, the conditions gradually altered. The writer travelled for some months in 1887 on the footplates of Great Western engines, both broad and standard gauge. On the latter a part of the road was laid with the old longitudinal sleepers, but much of it was on well-laid transverse sleepers with chairs. All the oldest and most experienced main-line drivers were unanimous in their opinion that their engines were "one or two coaches (six-wheeled) better on the transverse sleeper than on the 'baulk' road," meaning that they could pull thirteen or fourteen carriages on the former with the same ease as twelve on the latter. This of course, is a loose statement, but the writer himself certainly noticed a difference. The inference is that the resistances on the longitudinal sleeper road were greater, though the writer knows of no actual test figures which can be produced to prove it scientifically. It seems probable that for this reason alone Clark's formula for train resistance subsequently gave results too high, when the transverse sleeper road was improved by the adoption of steel rails of 80 lb. per yard and upwards. Moreover, the length of the carriages and of the train and the number of axles affect the result.

For similar reasons the locomotive performances of 1875-79, some of which are given later, are difficult to compare with those of to-day. The resistance per ton of the trains of those days was considerably greater than that of present-day trains, and more work had to be done by the engine in hauling a 150-ton train than is now the case. Many of the coaches were four-wheeled, though a large number on the principal main-line expresses were six-wheeled, but there were very few eight and twelve-wheeled bogie coaches, and these chiefly on the Midland. In the discussion on Sir John Aspinall's paper on "Train Resistance" ("Proc.," Inst. C.E., 1901), the author pointed out that M. Barbier, on the Northern Railway of France, had found that the resistance of four-wheeled vehicles was 20 to 30 per cent. higher than that of bogie coaches. The writer does not remember any statement of comparative resistances per ton of four and of six-wheeled coaches, except some experimental results of a later date by Leitzmann in Germany, which, owing to

the large size and heavy weight of the coaches, hardly apply to British practice.

In 1875-76 a train weighing 150 tons might be made up of sixteen four-wheeled coaches (thirty-two axles) or of twelve six-wheeled carriages (thirty-six axles), or some combination of both. A 150-ton train of modern stock would consist of five or six eight-wheeled bogie coaches, having twenty or twenty-four axles and better lubrication. Harder tires and heavier rails having a greater moment of inertia also tell greatly in favour of the locomotive of to-day. It is probably not far from the mark to assume that the average resistances per ton in 1875-79 at speeds of 40 to 60 miles per hour, were about 25 to 30 per cent. greater than now, taking all things into consideration. Finally, it must also be remembered that there was then no steam-sanding apparatus to *clean* as well as sand the rails on gradients, and that by far the greater number of trains had no continuous brake, a factor which very appreciably affected the maximum and average speeds on lines with even moderate gradients.

Great Western Railway.—The best performances on the G.W.R. broad gauge were undoubtedly made in 1848 to 1860, after which there was a falling-off. Rous-Marten records that he timed between twenty and thirty fast trains in 1856, drawn by the eight-wheeled 8ft. singles, with 18in. by 24in. cylinders. On a few very rare occasions when the trains were late and of light weight, speeds of 70 miles per hour and slightly over were attained, and on two or three occasions 72 miles per hour was reached for short distances between Swindon and London with the up trains, though these speeds were quite exceptional. He often found on the G.W.R., as on other lines, that the quickest actual speeds were made, not on the long runs, but by light trains on shorter runs of 15 to 30 miles. Engine "Crimea," with nine light coaches, ran from Paddington to Slough, 18½ miles, in a few seconds over 22 min., and having left four coaches there, ran with the remaining five to Reading, just over 17½ miles, in 17 min. 22 sec., a speed of over 60 miles per hour start to stop.

The 11.45 a.m. express from Paddington, known as the "Flying Dutchman," a train dating from about 1860, was timed at the rate of 53¼ miles per hour from Paddington to Swindon, as was also the corresponding train in the opposite direction. In its early days with light loads, the down train was said to have kept very good time, but in later years it lost time very frequently on the run to Swindon. The line rises gradually for practically most of the distance, and the prevailing wind is against the down train. A run in October, 1878, with engine "Sultan," the load being four eight-wheeled coaches and one six-wheeled van, about 100 to 105 tons, showed a loss of 3½ min. to Swindon without apparent cause. There is no doubt that the engine could have kept time, had

the driver wished, but rather than burn extra coal, it was usual to drop time to Swindon and afterwards regain it on the 29½ miles downhill run thence to Bath, which was timed at only 47 miles per hour. Until the abolition of the broad gauge in 1892, this was the usual method of working the train. On the up journey two or three minutes were frequently gained on the 87-min. schedule for the 77¼ miles, the gradient, and generally the wind also, being in favour of the train.

Great Eastern Railway, 1856.—Some of the most interesting of C. Rous-Marten's speed records of 1856 were obtained on this railway, then known as the Eastern Counties Railway. This line at that time, after the Great Western and Great Northern, ran some of the fastest trains in the country between London and Norwich *via* Cambridge. On the 4 p.m. down train from Bishopsgate a speed of 69.2 miles per hour was attained by engine No. 44 between Tottenham and Ponder's End. This engine was of the 2-2-2 type with outside cylinders 15in. by 22in. and 6ft. driving wheels, and was built by Jones and Potts in 1845. One of Stephenson's 1846 long boiler rear driver single engines, No. 102, with 6ft. 6in. driving wheels and 15in. by 24in. cylinders, similar to Fig. 58 *ante*—attained 70½ miles per hour between Park and Waltham on a down express, and speeds of nearly 70 miles an hour were reached by other engines of the same series—Nos. 98 to 102. The loads in all cases were from seven to nine four-wheeled carriages. The speeds of the long boiler engines were too high for safety; shortly afterwards the engines were converted to the 2-2-2 type with the driving wheels in the middle. It is probable that they had been carefully balanced by Fernihough.

South-Eastern Railway.—Another extraordinary record by the same observer was that of one of the South-Eastern inside cylinder—15in. by 22in.—rear driving wheel 6ft. "Cramptons," No. 138—Fig. 91 *ante*—by Stephenson, 1851, on an up Dover express with a load of no less than 24 small four-wheeled carriages. The train was 12 min. late at Redhill, and regained 7 min. to London Bridge, running at 60 miles per hour down the banks, and not falling below 45 miles per hour when once well away. Though most of the road from Merstham Tunnel is downhill, 7¾ miles at 1/264, and 2⅔ miles at 1/100, there is a 2½ mile rise of 1/264 from the dead start, so that the writer is inclined to the opinion that some error, most probably in the number of coaches, was made by Rous-Marten in this, one of his earliest timing experiences. In spite of the fact that the carriages were small, it is very doubtful whether such an engine could have started 24 of them and taken them up to the tunnel without losing a great deal of time.

Great Northern Railway Early Records.—On the standard gauge this line was *facile princeps*. In 1854 there was one, and in 1857 there were three

expresses which were booked to run from King's Cross to Hitchin, 32 miles, in 38 min.; speed, $50\frac{1}{2}$ miles per hour. This is even better than it looks, for the first $12\frac{3}{4}$ miles to Potters Bar are mostly uphill, starting with 1/105 to 1/110, followed by 3 miles nearly level, and finishing with a pull of 8 miles, averaging 1/200 to the summit. One of these trains was always worked by engines 91 to 99 of the 2-2-2 type, with outside bearings, cylinders 15in. by 21in., and 6ft. 6in. driving wheels. The others were worked either by 91 to 99 or by 203 to 214 by Hawthorn of a similar but larger type with 6ft. 6in. drivers and 16in. by 22in. cylinders—Fig. 100 *ante*. The loads, according to Rous-Marten, were usually 8 to 10 four-wheeled coaches. The trains reached Potters Bar in 18 minutes from King's Cross, the time seldom varying more than a few seconds. The bank was generally started, after the 3 mile level run, at about 50 to 55 miles per hour, and the same observer never knew the speed at the summit to fall below 45 miles per hour. The distance, $19\frac{1}{4}$ miles from Potters Bar to Hitchin, was frequently covered in 19 minutes, the maximum speed recorded near Hatfield being 69 miles per hour.

Very little further is known of actual performances until 1875, and probably nothing would have been recorded even then, had it not been that P. Stirling's single engines with their large 8ft. wheels attracted attention, and one or two people interested timed them in order to see how fast they could run. The timing of fast trains then spread to the rival London and North-Western Railway. Fortunately the reliable records of 1876-78 include performances of celebrated engines built between 1851 and 1870, as well as those of a later date, so that a very fair idea of the capabilities of several interesting classes can be made.

Speeds at the Newark Brake Trials.—The accurate data as regards loads and speeds of various engines tested at the brake trials on the Midland Railway between Rolleston Junction, near Newark, and Lowdham, in 1875, give the best particulars available of the capabilities of the engines of that day. Most of the engines used were new, having been built in 1871-75. It was intended to test the brakes when the speed reached 60 miles per hour, and though every possible effort was made to attain that speed in the course of slightly more than three miles of practically level road from the dead start, it was found, with the loads drawn, to be an impossible feat.

In a large number of runs the drivers, on reaching the last 800ft. of measured length, tried to get more speed by putting the reversing lever down without easing the regulator, but thereby choked the exhaust. In some cases this manœuvre actually reduced the speed before the brakes were applied. One instance will suffice. The Midland engine—890 class—working the train fitted with Clark's hydraulic brake, was running at 56 miles per hour at the end of a short rising gradient of

1 in 1200 at a point 1600ft. from the mark at which the brake was to be applied, and the driver, in endeavouring to increase the speed, actually reduced it to $54\frac{1}{2}$ miles per hour in running the 1600ft., although the ascending gradient throughout decreased to 1 in 2870. The speeds in the table on p. 235 are the maxima which the engines attained at any point of the measured course. The trains each consisted of 13 coaches and 2 vans, all of which were four-wheeled, except those of the Great Northern and the London and North-Western. The Great Northern train consisted of 13 six-wheeled coaches and two four-wheeled vans, and the whole of the 15 London and North-Western vehicles were six-wheeled. With the exception of the Caledonian, all trains were uniform in shape. The results are shown in Table III.

The fastest speed, $57\frac{1}{4}$ miles per hour, was attained by the North-Eastern engine, and Midland engine, No. 134, came next with 56 miles per hour to its credit, an excellent result considering that it was brand new, and had been only three or four days out of the shops at Derby. The pluckiest performance was that of the Lancashire and Yorkshire engine, which was much smaller and also much older than its competitors, and the manner in which it was handled by its driver, a man who knew his business thoroughly, excited universal admiration.

London and North-Western Railway, 1876-79.—The London and North-Western Railway did not unduly hurry its trains, and its performances were generally below those of the Great Northern Railway and frequently below those of the Midland. In July, 1876, the up day Scotch express was re-timed to run from Nuneaton to Willesden Junction, $91\frac{3}{4}$ miles, without stopping, at that time the second longest run in the country. The following three timings of this train are of exceptional interest in that three different types of engine, the McConnell 7ft. 6in. and 7ft. "Bloomer" classes, and a Webb "Precedent" took part. The train was booked to be worked by a "Precedent," of which there were twenty then in service, but when one was not available, McConnell's older engines were used. The 7ft. 6in. engine, No. 1199 "Caithness," was the identical engine shown at the 1862 Exhibition, subsequently renumbered and named. Both it and the 7ft. "Bloomer" No. 887 had been re-boilered, and the original 150 lb. pressure reduced to 120 lb., in spite of which they did excellent work. These three runs have not been specially selected; they are the only records with this train known to the writer.

The actual figures are given in Table IV, and it must be admitted that McConnell's "Bloomers" had by far the best of it. From Nuneaton to Crick—now Welton Station—is uphill on the whole, and the five miles out of Rugby are at 1/364. Roade to Wolverton is down hill, mostly at 1/335;

thence from Wolverton to Tring is a steady climb, the last six miles being at 1/330. From Tring to Willesden is downhill. The performance of the engine 887, with 7ft. wheels, 16in. by 22in. cylinders, hauling fourteen six-wheeled coaches, is very remarkable for an engine of such small tractive force. There was no extremely slow uphill running, followed by a violent rush down descending gradients; in fact, the fastest mile between the 81st and 27th posts was done in 61 sec., and the slowest in 103 sec. On the other hand, the four-coupled "Precedent" actually lost time between Nuneaton and Tring, in spite of the fact that it was 6½ min. late in starting. In consequence, it had to run faster downhill from Tring than either of the two single engines. With regard to the recorded loads, one account gives twelve or thirteen six-wheeled coaches as that taken by engine 1199 in column 1, but it is definitely known that engine 2194 (column 3) had one more carriage. The writer has therefore taken the lighter loads of twelve and thirteen respectively for the trains in columns 1 and 3. The fourteen-coach load of engine 887 is definitely known. The weights are averaged from those of the carriages in the Newark brake trials, which were of similar stock.

The following records, made in 1876-78, refer to the McConnell 7ft. "Bloomers," Nos. 889 and 997, and to the Ramsbottom 7ft. 7½in. "Lady of the Lake" class, Nos. 127 and 667, on down expresses from London. To save space the timings are not given in full in Table V.

The performance of the "Bloomer," No. 889, to Bletchley, beyond where it was not timed, was excellent, considering the load. The loads of the 4 p.m. down express in the last three columns were not recorded, but this train usually averaged about nine six-wheeled coaches. It was, however, stated that No. 127 "Peel" (Ramsbottom) on this occasion took one more coach than the "Bloomer" No. 997, "Baronet," so that the two performances in columns 2 and 3 were about equal in merit. It may also be remarked that the trains in columns 3 and 4 could have run considerably faster than they did from Crick—now Welton Station—to Rugby, most of the distance being downhill at 1/364.

In their later years, 1881-84, the "Bloomers" were frequently used on the fastest L. and N.W.R. express, the 2.10 p.m. from Birmingham to London, which was booked to run the 36 miles from Rugby to Bletchley in 41 min., average 52.7 miles per hour. The load was seven six-wheeled coaches, and Rous-Marten recorded that time was always kept, and that on one occasion engine 989 made the run in 40 min., *i.e.*, at 54 miles per hour, the maximum speed being 72 miles per hour.

The "Bloomers" were excellent engines, considering their small tractive power, and the secret of their phenomenal performances probably lay in the free exhaust. The Crewe authorities of that

period were said not to have been particularly fond of them for the reason that their performances were too uncomfortably good. The large engines, with 7ft. 6in. wheels, such as "Caithness," were relegated to secondary work whenever possible, though their services had to be requisitioned at times on the best trains. The main-line drivers used to say that Crewe was afraid of them.

There was another old L. and N.W.R. engine, the "Cornwall," with 8ft. 6in. wheels, and 17½in. by 24in. cylinders—Fig. 75 *ante*—whose doings are worth mention, though little is known of them. Rous-Marten recorded that in 1884 this engine ran from Crewe to Chester ticket platform 20¾ miles, in 25 min., and also from Stafford to Crewe, 24½ miles, in 29 min., start to stop; speed 50.7 miles per hour. Down Whitmore bank 70 miles per hour was recorded. He also mentioned that he found it an extremely steady engine on the footplate. The loads were not recorded.

Of the performances of the "Precursors" and "Precedents" between Crewe and Carlisle, there are unfortunately no authentic records during this period.

Time has its revenges. The fine work of the single engines on the southern division of the L. and N.W.R. could not escape attention, and although Webb was a staunch advocate of coupled engines until 1882, he made a very special point of designing his three-cylinder compound engines with two sets of independent driving wheels in an attempt to obtain the advantages of the singles. But it was just this omission of coupling-rods in the wrong engines that was one of the chief factors which adversely affected the compounds.

South-Eastern Railway.—The fine 7ft. "single" engines, with 17in. by 22in. cylinders, by Cudworth, did some excellent work. Rous-Marten recorded in 1884 that No. 204 (Kitson, 1861), with the Dover express, ran from Cannon-street to passing Ashford, 54¾ miles, in 74 min., with a load of about 150 tons. This is better than it looks, since there are 12 miles to be climbed from New Cross up the Halstead bank, mostly at 1/120 to 1/146. The time taken for this stretch was 21 min., a mean speed of about 35 miles per hour.

Great Northern Railway, 1875-79.—In 1875 the fastest runs were from King's Cross to Peterborough, 76½ miles in 90 min., at the rate of 50.8 miles per hour, and Grantham to York, 82¾ miles in 103 min., speed 48½ miles per hour. In 1876 the 10 a.m. from Leeds was booked from Wakefield to Grantham, 70½ miles, at the rate of 50.4 miles per hour, from Grantham to Peterborough, 29 miles, at 51.2 miles per hour, and from Peterborough to Finsbury Park, 73¾ miles, at 52.1 miles per hour. These runs were generally done by the 8ft. single engines, except the one from Grantham to York, which was frequently performed by one of the smaller 7ft. singles with inside cylinders.

The 2.45 p.m. down from King's Cross, a heavy

train, was often worked by one of the older 7ft. single engines with outside frames, of Sturrock's design, reboilered by P. Stirling. A timing of one of these engines, No. 236, built in 1861 by Sharp, Stewart, with cylinders enlarged to 17in. by 24in., and 140 lb. boiler pressure, showed that with a load of no less than sixteen coaches, many of which were six-wheeled, the 12 $\frac{3}{4}$ -mile climb to Potters Bar from the dead start was performed in 19 min. 49 sec. The 7 $\frac{3}{4}$ miles mostly at 1/200, from the 5th post to the summit, were covered in 10 min. 50 sec., at an average speed of nearly 43 miles per hour. The next 4 $\frac{1}{4}$ miles to the 17th post, where three carriages were slipped for Hatfield, were done in 4 min. 47 sec.

Another 7ft. "Sturrock," No. 229 (Kitson), rebuilt with 17in. by 24in. cylinders, was timed in 1884 by Rous-Marten from London to Peterborough, 76 $\frac{1}{4}$ miles, in 88 min., with 13 six-wheeled coaches weighing 159 tons. The engine cleared the summit at Potters Bar in 19 min., the lowest speed up the bank being 45 miles per hour. No. 234 (Sharp, Stewart) of the same class, was also timed by Rous-Marten with 16 coaches from Peterborough to Finsbury Park in the booked time of 91 min. for the 73 $\frac{3}{4}$ miles, in spite of a special stop at Huntingdon of nearly 2 min. There are two long banks of 1/200, five and seven miles long respectively, to be climbed on this run.

In estimating the following performances of Stirling's 8ft. singles due consideration must be paid to the fact that in the later period from 1880 to 1895 they did much finer work, as both loads and speeds were increased on the average above those of 1875-79. Engine No. 22 of this class ran from King's Cross to Peterborough in October, 1875, with 18 carriages, 76 $\frac{1}{4}$ miles, in 92 min.; speed, 49 $\frac{3}{4}$ miles per hour. This train would be made up of both six and four-wheeled stock. The same engine on the evening Scotch express with 12 six-wheeled E. C. J. S. coaches, performed the same journey in 88 $\frac{1}{2}$ min. at the rate of about 51.8 miles per hour. On another occasion, in 1876, with the same engine and train, but with a lighter load of 10 six-wheeled coaches, the 12 $\frac{3}{4}$ miles from the dead start to Potters Bar took 19 min., and the succeeding 56 $\frac{1}{2}$ miles thence to Holme were covered in 59 $\frac{1}{2}$ min. The same engine, No. 22, with 16 coaches, nearly all six-wheeled, passed Potters Bar in 20 $\frac{1}{4}$ min. from King's Cross. The 46 miles from Potters Bar to passing Huntingdon were done in 49 $\frac{1}{4}$ minutes, and Peterborough was reached in 89 min., or 1 min. under time.

Engine 48 of the same class with 11 six-wheeled coaches on the 10 a.m. Scotch express climbed up to Potters Bar, 12 $\frac{3}{4}$ miles, from the dead start, in the remarkable time of 17 min. 40 $\frac{1}{2}$ sec. The 8 miles from posts 5 to 13, nearly all at 1/200 up, were covered in 10 min. 7 sec., at the average speed of 47 $\frac{1}{2}$ miles per hour. With 10 coaches the same engine ran from passing Potters Bar to the 70th

milepost, 57 $\frac{1}{4}$ miles, at the rate of 56.6 miles per hour.

Of the 7ft. Stirling singles the only record of this period known to the writer is one made in 1878 with the down Scotch express from Grantham to York, when engine No. 14, with 10 six-wheeled coaches, covered the 82 $\frac{3}{4}$ miles in 97 $\frac{3}{4}$ min.; speed 50.8 miles per hour. The booked time for this run in 1878 was 99 min.

Very few express trains on the Great Northern were worked by four-coupled engines.

Before leaving the Great Northern it may be as well to mention one or two apocryphal statements which at one time were published concerning the 8ft. single engines. There was a startling statement in 1875 that one of them had run 12 miles in 8 min., or 90 miles per hour. It is certain that nothing of the sort was ever done. In *The Engineer* of May 22nd, 1874, it was mentioned on the authority of P. Stirling himself that one of these engines with a load of 16 carriages had covered a distance of 15 miles in 12 min. The fact is that the timing of trains by railway officials used to be notoriously inaccurate, and the Great Northern official who reported this trip to Mr. Stirling was no more accurate than others. The time was taken very loosely with a minute hand watch, and C. Rous-Marten stated that when an attempt to repeat the performance was made, it proved impracticable with such a load. It subsequently became known that one of the mile posts had been temporarily moved during repairs to the road.

But what was impracticable in 1873 with the light rails and soft tires of that day would have been quite within the bounds of possibility for the same engines in 1893 with the heavier rails and harder tires then in use. Whereas in 1884-87 75 to 76 miles per hour was the maximum speed recorded either by Rous-Marten or the writer with these engines down the long bank from the 100th mile-post to Werrington Junction, and these speeds only for a mile or two, Rous-Marten in 1893-94 timed them at speeds of 80 to 83 miles per hour. A diminution in the resistance per ton of the newer carriage stock might partly, but by no means entirely, account for the increase of speed.

Midland Railway, 1874 to 1879.—Authentic speed records on this railway are very scanty. There was the usual crop of official timings of an exceeding looseness. The following run was made in March, 1874, by a very light special express of two Pullman cars from Derby to St. Pancras, drawn by 2-4-0 engine No. 906 (Neilson, 1871, Fig. 246 *ante*) with 6ft. 8 $\frac{1}{2}$ in. coupled wheels, 17in. by 24in. cylinders, and 140 lb. pressure:—

Miles.	Arr.	Dep.	Speed.
	p.m.	p.m.	
— ... Derby ...	—	2.30	—
33 $\frac{1}{2}$... Wigston ...	3.7	3.12	54.3
79 $\frac{1}{4}$... Bedford ...	4.0	4.3	57.2
129 ... St. Pancras ...	5.0	—	52.4

This was an official timing, and the figures are given only to the nearest minute. It may be accepted as approximately correct as far as the overall speeds are concerned, but when it was officially added that 17 consecutive miles were run in 13 min. 28 sec., *i.e.*, at a continuous speed of 75.6 miles per hour, the writer must be pardoned for stating frankly that he is sceptical. There are authentic records of Midland maximum speeds of $72\frac{1}{2}$ miles per hour in 1876 down the Desborough and Market Harborough banks, but only for a mile or two. It is possible that the special express attained 75 miles per hour for a short distance.

The following is a good example of Midland heavy work in 1878. The train was the down night Scotch express, timed from Leicester to Carlisle, with an exceedingly heavy load to Skipton, consisting of 2 eight-wheeled Pullman cars, each 58ft. long, 2 12-wheeled bogie coaches of the 1876 pattern, each 40ft. long over bodies, 6 six-wheeled carriages, and 3 four-wheeled vans; total, 44 axles, and weight empty, about 202 tons. The train was fitted throughout with the Westinghouse brake.

The 2-4-0 engine from Leicester to Normanton, No. 814, was of the celebrated rebuilt double-framed 800 class—Fig. 245 *ante*—having 18in. by 26in. cylinders, 6ft. 8in. coupled wheels, 1225 square feet of heating surface, and 140 lb. pressure. The $20\frac{3}{4}$ level miles from Leicester to Trent (stop) were run in $26\frac{1}{2}$ min., equal to 47 miles per hour. From the start at Trent to passing Chesterfield at full speed the rate was 46.3 miles per hour; and thence the $5\frac{1}{4}$ miles to Dronfield up the steep 5-mile bank of 1/100, averaged $39\frac{1}{4}$ miles per hour. The speed down the 1/100 fall on the northern side was only 45 miles per hour to the stop at Sheffield, and the mean speed for the $38\frac{1}{2}$ miles from Trent was 44.4 miles per hour. From Sheffield to Normanton the average was $46\frac{1}{4}$ miles per hour for the $28\frac{1}{2}$ miles, including the slack to very reduced speed round the very sharp curve from Holmes to Masborough. Between Normanton and Skipton with another engine there were two severe slacks and one booked stop. At Skipton the train was divided, as extra coaches from Bristol had been put on at Normanton, and additional carriages from Manchester came on at Skipton. The load of the first part from Skipton was about 120 tons, drawn by 2-4-0 engine 1307 (Dübs, 1876), which had 6ft. 6in. coupled wheels, 17 $\frac{1}{2}$ in. by 26in. cylinders, and 140 lb. pressure. The line from Settle Junction rises 15 miles at 1 in 100 continuously, but unfortunately the time in passing the summit at Ais Gill was not recorded, though it was taken at Mallerstang signal-box, $3\frac{1}{2}$ miles further on. The time from the Skipton start to this point, 42 miles, was just under 61 min., climbing almost the whole distance. Passing Mallerstang to a signal stop at Howe's Siding, $39\frac{3}{4}$ miles, the

average speed was 56.8 miles per hour. The run from Skipton to the signal stop, $81\frac{3}{4}$ miles, over the summit at 1167ft. above sea level, was accomplished at the rate of 47.6 miles per hour. The whole run from Leicester showed really excellent locomotive work, in one case with a heavy train, and in the other over severe gradients.

Coal Consumption.—Only official figures for 1873 to 1879 are available, some of which have a peculiar elasticity. The first engine of the ill-starred "Precursor" class of the L. and N.W.R., with small 5ft. 6in. wheels, was officially stated to have run for 11 months with an average net load of 141 tons—gross load, including engine and tender, 187 tons—on a consumption of 33.2 lb. per mile. This was not very wonderful, for the Midland engines of the 800 and 1300 classes were running between Leeds and Carlisle over an equally heavy road with almost exactly similar average loads on a mean consumption of about 31 lb. of Yorkshire coal per mile. The latter is not an officially announced record, but one which the writer himself copied from the coal sheets in the engine sheds, and which he can therefore guarantee.

The official coal consumption of the "Precedents," with 6ft. $7\frac{1}{2}$ in. wheels, depended upon the engines with which they were to be compared. At one time they were stated to have burnt 26 lb. per mile, with an average of 10 coaches, and if they be allowed 31 lb. to 32 lb. per mile between Crewe and London for an average of 14 coaches, that is what they should have burnt *pro rata*. When the first compound engines appeared the "Precedents" were stated by Mr. Webb to have consumed 34.6 lb. per mile, and the saving of fuel credited to the compounds was thereby increased. The writer does not know what these engines consumed before 1879, but he has some running shed sheets of 1884-85, from which the following figures give the actual consumptions:—

Shed.	Route.	Lowest engine, lb. per mile.	Highest engine, lb. per mile.	Average lb. per mile.	No. of engines.
Rugby	London and Crewe only	37.1	47.5	43	7
Rugby	London, Crewe and Manchester link	38.7	45.2	41.9	7
Crewe	Crewe and Carlisle only (1st link) .	34.0	39.0	36.3	7
Crewe	Crewe and Rugby, Crewe and Carlisle (2nd link) .	33.0	38.0	36.5	6

The coal burnt was usually Welsh. The loads between Crewe and Carlisle were lighter than between London and Crewe, and the engines were frequently piloted. The *average* loads were not given on the sheets, but since official figures in connection with the "Dreadnought" compounds—published in *Engineering*, May 1st, 1885, page 472—gave the average load south of Crewe of the latter engines as 12 coaches, it will be very nearly correct to assume that the *mean* loads of the "Precedents" were $11\frac{1}{2}$ to 12 six-wheeled

carriages, though 15 and 16 were sometimes taken. The 10 a.m. Scotch express in October, 1883, consisted of 12 coaches, having a total weight of 141 tons 7 cwt., the average weight per coach being 11 tons 15½ cwt., or, say, 11¾ tons. Although the "Precedents" were in many respects good little engines, they were really too small, and of insufficient boiler power. The result was that they had to be forced and a large amount of unburnt fuel was thrown out of the chimney. That this was the case was obvious from the pyrotechnic displays which they produced at night with any load over 9 or 10 coaches.

McConnell's "Bloomers," between Crewe and London in 1872-73, were officially stated to have burnt 27 lb. to 28 lb. per mile; this figure is probably correct, but the trains were lighter then.

The Great Northern 8ft. single engines in 1873 were credited with 27 lb. of Yorkshire or Nottinghamshire coal with loads of 16 coaches, including the fuel for getting up steam. If this meant the average consumption over a considerable period, it seems too little for loads of 175 to 190 tons, though there most probably were occasions during fine weather when such a result was achieved. Nevertheless, they were undoubtedly extremely economical engines, and the writer regrets that he has none of their records from the running shed coal sheets.

Table VI gives Midland shed records for 1884-85, which since they relate to classes of engines previously described, may suitably be included here. All these, as well as the previous figures, were obtained by the writer from the coal sheets posted in the engine sheds.

The average loads may be estimated by taking the weight of a coach as about 11¾ tons. The Hellifield engines worked exclusively, and the Skipton engines principally, over the heavy gradients of the Carlisle road. The Carnforth engines worked both fast and ordinary trains, and it is a curious fact that one of them, engine 1404, which burnt only 24.8 lb. per mile and was the lowest on the list, had 49 out of 221 tubes

plugged up, owing to a defective tube plate, during the month covered by the coal sheet. The records for the other sheds represent six months' working, and altogether they show good and economical locomotive work. The oil used by the Skipton and Hellifield engines, 800 and 1302 classes, averaged 3.9 lb. per 100 miles.

Finally, mention may be made of similar records of E. Fletcher's North-Eastern 7ft. coupled main line express engines—Fig. 247—with 17in. and 17½in. by 24in. cylinders, and 140 lb. pressure. An original coal sheet of 1884 from Gateshead shed in the possession of the writer, shows that 13 engines in the No. 1 link, running between Newcastle, Berwick and Edinburgh, burnt 28.4 lb. per mile, with an average load of 12.16 coaches. The two best engines, Nos. 845 and 847—Beyer, Peacock, 1873—accomplished wonderful performances in burning only 24.9 lb. per mile, each with loads of 16 coaches. The highest engine in the link consumed 31.6 lb. with 12 coaches. In No. 2 link, running between Newcastle and York, with one turn to Leeds, there were 15 engines burning an average of 30.85 lb. per mile, with 12.3 coaches. Of these the best, No. 926—Neilson, 1873—consumed 26.7 lb. per mile with 12 coaches, but the highest consumption reached 38.3 lb. Probably the engine with the latter record was not in good order.

Comparing the Midland and North-Eastern records of 2-4-0 engines with those of the London and North-Western, the good effect of ample boiler power in the former cases is extremely marked. Moreover, the London and North-Western main line engines used best Welsh, the North-Eastern Northumberland and Durham coal, and the Midland Yorkshire and Derbyshire coal. The relative evaporative values of these fuels, from and at 212 deg. Fah., may be taken respectively at 9 : 8.4 : 7.6 when efficiently burnt.

The above records of coal consumption may be borne in mind when compound locomotives come under subsequent consideration.

TABLE III.—Locomotive Performances at the Newark Brake Trials, 1875

Railway.	Class of engine.	Type.	Diameter of driving wheels.	Cylinders.	Steam and exhaust ports.	Valve travel, full gear.	Outside lap.	Inside lap.	Lead, full gear.	Heating surface.			Grate area, square feet.
										Tubes, sq. ft.	Fire-box, sq. ft.	Total, sq. ft.	
G.N.R.	" 4 " class (Fig. 214) ...	2-2-2	7 1	17×24	14×1½/2½	4½	1½	None	¼	919	100	1019	16.4
L. and N.W.R.	" Precedent " class (Fig. 250).	2-4-0	6 7½	17×24	14×1½/3½	4½	1½	None	—	980	103.5	1083.5	17.1
N.E.R.	" 901 " class (Fig. 247) ...	2-4-0	7 0	17×24	13×1½/3½	4 9/16	1½	1/16	3/16	1110	98.5	1208.5	16
M.R. (1)	" 130 " class ...	2-4-0	6 8½	17×24	15×1½/3½	4½	1	None	¾, full	1115	110	1225	17.5
M.R. (2)	" 130 " class ...	2-4-0	6 8½	17×24	15×1½/3½	4½	1	None	¾, full	1115	110	1225	17.5
M.R. (3)	" 890 " class (Fig. 246) ...	2-4-0	6 8½	17×24	15×1½/3½	4½	1	None	¾, full	1028	94	1122	16
L.B. and S.C.R.	Grosvenor (Fig. 243) ...	2-2-2	6 9	17×24	15×1½/2	4	¾	None	—	1022	110	1132	19.3
C.R.	" 30 " class (Fig. 219) ...	2-4-0	7 2	17½×24	?	5	1½	None	5/16	698.6	82.3	780.9	15.1
L. and Y.R.	" 286 " class ...	2-4-0	5 9	15×22	?	?	?	?	?	?	?	?	?

Locomotive Performances at the Newark Brake Trials, 1875 (continued).

Railway.	Class of engine.	Boiler pressure, lb. per sq. in.	Tractive force per lb. M.E.P., lb.	Weight of engine, tons.	Weight of tender, tons.	Weight of train, tons.	Weight of tender and train, tons.	Weight of engine and train, tons.	Weight of engine, tender and train, tons.	Number of axles in train.	Max. speed, in miles per hour.	Remarks.
L. and N.W.R.	" Precedent " class (Fig. 250).	140	87.21	33,912	22,862	184,687	207,55	211,462	211,462	45	50.75	
N.E.R.	" 901 " class (Fig. 247) ...	140	82.55	39,075	27.65	136,887	164,537	203,612	203,612	30	57.25	N.E.R. engines and L. & Y.R. train.
M.R. (1)	" 130 " class ...	140	86.15	38,237	24.1	140,875	223,25	262,325	262,325	43	49.5	N.E.R. engine and G.N.R. train.
M.R. (2)	" 130 " class ...	140	86.15	38,325	23.9	147,875	171,775	210.1	210.1	30	51.0	Westinghouse automatic brake.
M.R. (3)	" 890 " class (Fig. 246) ...	140	86.15	36,625	26.2	135,375	161,575	198.2	198.2	30	56.0	Barker's hydraulic brake.
L.B. and S.C.R.	Grosvenor (Fig. 243) ...	140	85.61	35,375	28.2	139,875	168,075	203.55	203.55	30	54.5	Clark's hydraulic brake.
C.R.	" 30 " class (Fig. 219) ...	130	85.4	35.8	26,612	134.95	161,562	197,362	197,362	30	49.5	
L. and Y.R.	" 286 " class ...	?	71.75	27,887	21,875	136,887	158,762	186.65	186.65	30	48.5	

TABLE IV.—*L. & N.W. Up Scotch Express, 1877-78*

Miles.	Stations.	1877.		August, 1878.		1877.	
		Engine 1199, "Caithness," McConnell, Wolverton, 1862, 18"×24", 7' 6", 120 lb., 2-2-2.		Engine 887, "Knowsley," McConnell, Sharp, Stewart, 1852, 16"×22", 7', 120 lb., 2-2-2.		Engine 2194, "Cambrian," Webb, Crewe, 1875, 17"×24", 6' 7½", 140 lb., 2-4-0.	
		Speed, h. m. s. m.p.h.		Speed, h. m. s. m.p.h.		Speed, h. m. s. m.p.h.	
3¾	Nuncaton ... dep.	0 0 0		0 0 0		0 0 0	
5¾	Bulkington ... pass	0 7 0		0 6 45		0 7 0	
9	Shilton ...	0 9 40	44.6	0 9 25	42.4	0 10 0	40.25
14½	Brinklow ...	0 13 25		0 13 10		0 14 0	
21½	Rugby ... slack	0 19 10		0 20 10		0 21 15	
27½	Crick ... pass	0 30 0		0 31 20		0 32 35	
34½	Weedon ...	0 36 5	48.6	0 37 35	47.32	0 39 5	46.1
37½	Blisworth ...	0 43 45		0 45 10		0 47 5	
44½	Roads ...	0 47 25		0 49 10		0 51 5	
50¾	Wolverton ...	0 55 30	>55.7	0 57 35	>53.5	0 59 50	>51.4
56¾	Bletchley ...	1 2 0		1 4 10		1 6 15	
61	Leighton ...	1 9 45	49.15	1 12 10	46.4	1 14 30	47.0
65¾	Cheddington ...	1 14 45		1 17 25		1 19 30	
69¾	Tring ...	1 20 50		1 24 25		1 26 20	
72½	Berkhampstead ...	1 25 20		1 29 30		1 31 0	
76	Boxmoor ...	1 29 15		1 33 15		1 34 15	
79½	King's Langley ...	1 33 10		1 36 55		1 38 30	
81½	Watford ...	1 37 20	51.5	1 40 45	51.5	1 42 10	53.93
83½	Bushey ...	1 39 10		1 42 35		1 43 40	
85½	Pinner ...	1 42 25		1 45 55		1 47 0	
89½	Harrow ...	1 44 35		1 48 10		1 49 0	
91½	Wilkesden ... arr.	1 52 0	>46.0	1 55 15	>50.83	1 56 15	>49.9
	Load ...	12 coaches, 147½ tons		14 coaches, 172 tons		13 coaches, 160 tons	
	Average speed, start to stop ...	49.17		47.8		47.25	

TABLE V.—*L. & N.W. Down Expresses, 1876-78*

Miles.		McConnell's "Bloomers," 7', 16"×22", 120 lb. (inside).				Ramsbottom's "Lady of the Lake" class, 7' 7½", 16"×24", 120 lb. (outside).					
		889 "Camilla," Sharp, Stewart, 1852.		997 "Baronet," Wolverton, 1862.		127 "Peel," Crewe, 1862.		667 "Marmion," Crewe, 1863.			
		h. m. s.	m.p.h.	h. m. s.	m.p.h.	h. m. s.	m.p.h.	h. m. s.	m.p.h.		
	Wilkesden ... dep.	0 0 0		0 0 0		0 0 0		0 0 0			
26½	Tring ... pass	0 32 30	48.25	0 35 30	44.15	0 35 15	44.5	0 34 5	46		
41½	Bletchley ...	0 48 30	56.25	0 51 0	58.1	0 51 0	57.15	0 49 35	53.1		
46½	Wolverton ...	Stop.		0 56 40	60.9	0 56 50	62.0	0 55 55	54.5		
54½	Roads ...			1 6 55	44	1 6 30	44.7	1 6 0	44.6		
69¾	Crick ...			1 24 25	52.7	1 24 30	51.25	1 25 10	48.2		
77½	Rugby ... arr.			1 33 45	49.8	1 35 0	44.4	1 35 30	45		
	Load ...	12 coaches, about 147 t.				49.5 m.p.h.		48.8 m.p.h.		48.6 m.p.h.	
	Average speed, start to stop ...	50.9 m.p.h.									
	Train ...	to Bletchley stop 2.45 p.m. down, Manchester and Liverpool exp.				4 p.m. down, Manchester exp.		4 p.m. down, Manchester exp.		4 p.m. down, Manchester exp.	

TABLE VI.—*Midland Railway Coal Consumption*

Shed.	Class of engine.	Illustration Fig. No.	Road worked over.	Coal consumption, pounds per mile.			Average load, carriages.	Number of engines.	
				Lowest.	Highest.	Average.			
Leeds	1502, 2-4-0, 6ft. 9in., 18in.×26in., 140 lb.	273	Leeds and Nottingham, Leeds and Birmingham	23.4	30.5	26.75	10.81	14	Six months
Skipton	Rebuilt "800" class, 6ft. 8in., 18in.×26in. and 18in.×24in., 140 lb.	245	Skipton and Carlisle, Skipton and Leeds	28.5	33.3	30.6	11.47	7	Westinghouse fitted for Scotch expresses, six months
Hellifield	1302, 2-4-0, 6ft. 6in., 17½in.×26in., 140 lb.	Similar to 273	Hellifield and Carlisle	29.7	32.2	31.14	11.43	5	Ditto, six months
Carnforth	1400, 2-4-0, 6ft. 9in., 18in.×26in., 140 lb.	273	Carnforth and Leeds	24.8	28.2	25.8	9.19	4	One month

Chapter XVII

Engines for Ireland and Overseas, 1870-79

IRELAND.—Only one type of locomotive for the 5ft. 3in. gauge requires mention, since others were similar to those in Great Britain. The exception is the 0-6-4 tank engine, of which many were in service in Ireland long before the type made its appearance on any British standard gauge railway, though there were 0-6-4 Fairlie engines, with one steam bogie, on the North Wales

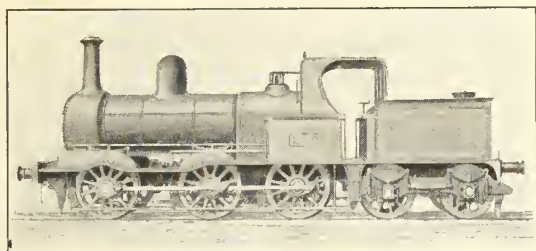

FIG. 297.—A. McDONNELL'S G.S. AND W. RLY. ENGINE, 1876

Narrow Gauge Railway, which were built by the Vulcan Foundry in 1874.

The 0-6-4 wheel arrangement was introduced into Ireland by A. McDonnell in 1876, when the first two engines—Fig. 297—were built at the Inchicore Works of the Great Southern and Western Railway, for hauling goods trains up heavy gradients in the Dublin and Cork districts. The coupled wheels were of cast iron, and the bogie had outside framing. Later engines of the type had side tanks.

The engine—Fig. 298—was originally designed and built by Beyer, Peacock in 1879 for the 5ft. 3in. gauge railways of South Australia, and had 4ft. coupled wheels. A modification of the drawings produced the class illustrated, with 4ft. 9in. coupled wheels. There is a number of these engines in service on the Sligo, Leitrim, and Northern Counties Railway—5ft. 3in. gauge—built by the above-named firm 1882-1899; all had side tanks and inside framed bogies. Dimensions of these and other classes illustrated are given in Table VII at the end of the chapter.

Continental European Locomotives.—In 1872 Neilson and Co. built a number of 0-6-0 tender engines with Sturrock's steam tenders for the Cordova and Espiel Railway of Spain. They were long boiler engines with outside cylinders 15 $\frac{3}{4}$ in. by 23 $\frac{5}{8}$ in. and coupled wheels 3ft. 5 $\frac{3}{8}$ in. diameter. The tenders, which had wheels of the same diameter, differed from Sturrock's usual design in that, as in the engines, the cylinders, 13 $\frac{3}{8}$ in. by

19 $\frac{3}{8}$ in., and the Gooch valve gear were also outside. The design was, it appears, of French origin.

Two classes of express engine, designed and built by Beyer, Peacock and Co., for the Dutch State Railways, merit attention. The first was the standard express engine of 1872-79, of which 50 were built of the 2-4-0 type with outside horizontal cylinders. The leading and driving springs were connected by compensating levers. The large and roomy cabs formed a prominent feature. This type with outside cylinders was specified by the locomotive department of the railway, but it was subsequently considered that the usual British type with inside cylinders was preferable. This decision resulted in the engines shown in Fig. 299, of which no less than 178 were built by Beyer, Peacock and Co. from 1880 to 1895. The frames are double throughout, with four bearings for the crank axle. The fire-boxes are of the Belpaire type. These engines have for many years been used not only for heavy express trains, but also as universal engines for goods traffic, in spite of their large 7ft. wheels. They have always given the greatest satisfaction, and have rendered excellent service. Subsequently 125 additional similar engines having leading bogies were built by the same firm.

The first Belpaire fire-boxes constructed in this country were made in 1872 by Beyer, Peacock and Co. for the Malines-Terneuzen Railway, Belgium—Fig. 300. They had the usual long grates and flat tops. As already noted, flat-topped casings had been used from 1865 by William Bouch on the Stockton and Darlington section of the N.E.R.

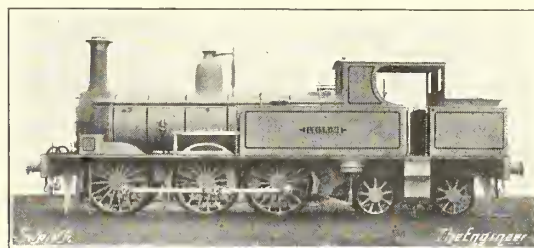

FIG. 298.—SLIGO, LEITRIM AND NORTHERN COUNTIES RLY. ENGINE BY BEYER, PEACOCK & CO., 1882

Other Engines for Overseas.—Space will not permit of mention of more than a few examples. The first engine which ran on the Imperial Japanese Railways—3ft. 6in. gauge—was built by the Vulcan Foundry in 1870—see *The Engineer*,

February 24th, 1871—and was followed by similar but slightly larger tank engines by Stephenson and Dübs in 1873. These engines worked between Tokio and Yokohama, but as the railways were extended 4-4-0 tender engines were

in 1874 for the heavy gradients of the New South Wales Railways. Both were of the 0-6-0 type with inside cylinders. Those of the goods engines were 19in. by 26in., the coupled wheels being 4ft. diameter. The passenger engines had 5ft. six-

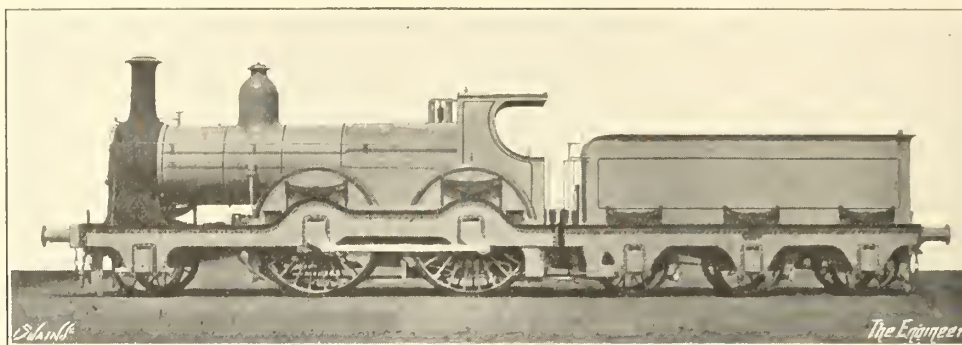

FIG. 299—EXPRESS ENGINE FOR THE DUTCH STATE RAILWAYS BY BEYER, PEACOCK & CO., 1880-95

built. Of these the first were built by Kitson and Co., 1874-76.

Another engine by Kitson, 1879—Fig. 301—represents the standard type used on the Natal Government Railways—3ft. 6in. gauge—in the early days of railways in that Colony, before the traffic had grown to an extent necessitating the heavier eight wheels coupled engines of 1888. The valves were above the cylinders, worked by rocking shafts from inside Stephenson link

coupled wheels, and cylinders of the then large size of 19in. by 28in.

Tabulated dimensions of the engines mentioned are given in Table VII.

Other interesting engines of various types for overseas were described and illustrated by the writer in the "Histories of Famous Firms" Series in *The Engineer* as follows:—Yorkshire Engine Company, August 18th, 1922; Neilson and Co., December 1st, 1922; Sharp, Stewart

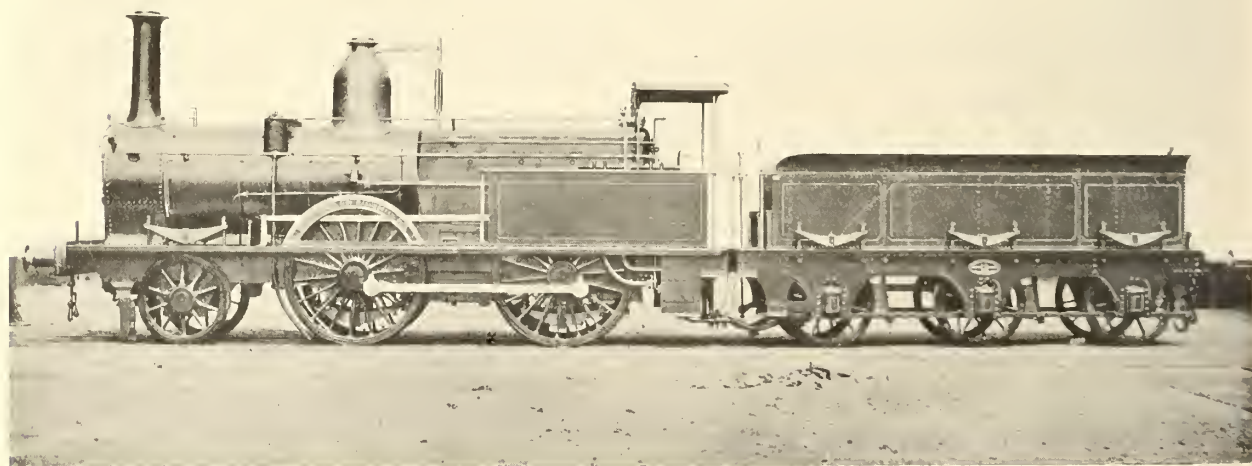

FIG. 300—BEYER, PEACOCK & CO.'S ENGINE, MALINES-TERNEUZEN RLY., 1872

motion, the side tanks being raised to give access to the gear. Similar engines were built by R. Stephenson and Co.

A number of heavy goods and passenger tender engines were built by Messrs. Stephenson

and Co., August 24th and 31st, 1923; and Kitson and Co., November 23rd, 1923, to which reference may be made.

Metre Gauge Locomotives.—Indian Railways.—The Indian 5ft. 6in. gauge engines during the

period 1870-79 call for no special mention, but the development of the metre gauge engines is of considerable interest, as they represent designs not used in this country. The early metre gauge railways were feeders to the broad gauge main

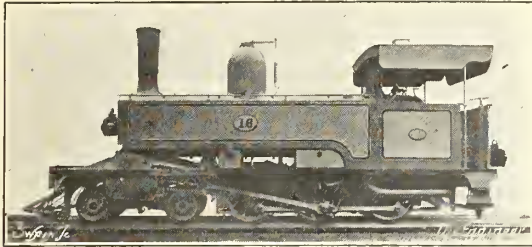

FIG. 301—TANK ENGINE FOR NATAL GOVERNMENT RLYS.—KITSON & CO., 1879

lines, and the earliest locomotives were small tank engines, of which there were three different types.

Fig. 302 shows the first of these 2-4-0 tank engines with outside cylinders, which were built by Dübs in 1872-74. To obtain sufficient width of fire-box the frames were placed outside the wheels, and the outside cranks were of Hall's type, to which reference is made on p. 240. The valves were above the cylinders and worked by rocking shafts from inside Stephenson gear. The dimensions of these and other Indian metre gauge engines are given in Table VIII.

Some smaller 0-4-2 engines were built by Nasmyth, Wilson and Co., in 1873, for lines in the North-West Provinces. They had inside cylinders 9in. by 14in., outside frames and cranks of the ordinary pattern. Only a limited number were built, and the type was not perpetuated.

The third type—Fig. 303—differed from the others in having outside cylinders, 11in. by 18in.,

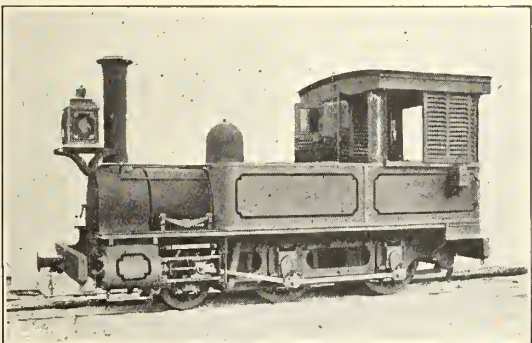

FIG. 302—METRE GAUGE TANK ENGINE FOR INDIA—DÜBS & CO., 1872

in combination with inside frames, and had the 0-4-4 wheel arrangement with trailing bogie. The first engines of 1872-73 were built by Nasmyth, Wilson, and by Dübs. This type, with modifications, has been retained, a few having been built during the present century.

Subsequently metre gauge railways of greater length such as the South Indian Railway, were made, and for these tender engines were necessary. Some early 0-6-0 goods engines for this railway, made by Neilson and Sharp Stewart, had frames inside the wheels. They were built from 1874 to 1880, when they were superseded by the well-known "O" class.

For the Indian State lines, such as the northern—metre gauge—division of the Eastern Bengal Railway, the Vulcan Foundry and Messrs. Neilson built 0-4-2 goods engines, with six-wheeled tenders. Single slide bars were used, an arrangement which became standard on all I.S.R. metre gauge engines, though the South Indian Railway retained double bars.

Fig. 304 shows one of the well-known 0-6-0 engines of the Indian State "F" class, of which hundreds were built by various firms during many years. The first engines, which had 13½in. by 20in. cylinders, were built by Dübs and the Yorkshire Engine Company, 1875-76, but the majority of the standard 14in. engines were by Neilson, Dübs, and the Vulcan Foundry. The engine illustrated was made by the last-named firm. Outside frames with Hall's cranks were

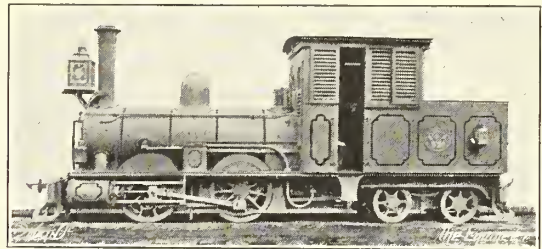

FIG. 303—METRE GAUGE ENGINE FOR INDIA, 1872

adopted, and the connecting-rods were on the inside of the coupling-rods. Many of the metre-gauge engines used wood fuel. According to a letter containing particulars of these engines, written by an Indian locomotive superintendent, and published in *The Engineer*, July 7th, 1893, the usual loads were 425 tons, but he had tested them with 600-ton trains at 15 miles per hour between stations. These trains they worked with ease, except up gradients of 1 in 200, where the speed fell to 5 or 6 miles per hour. In addition to the dimensions of the "F" class given in Table II., it may be added that the distance between the frames was 3ft. 11½in. and between centres of cylinders 5ft. 6½in. The boiler centre was 5ft. 3½in. above rail level.

The Rajputana-Malwa Railway, now part of the metre-gauge section of the Bombay, Baroda and Central India Railway, has always shown a preference for locomotive designs different from the standards of the Indian State Railways. Fig. 305 shows one of thirty-five 4-4-0 passenger engines by Dübs and Co., 1880, the principal

feature of which was the inside position of the cylinders. The driving axle was of the "half-crank" type, similar to that of early engines by Baldwin, and also by Stephenson for America. The outside cheeks of the inside cranks were

service of J. A. Maffei, the well-known locomotive builder of Munich, where he invented the crank which bears his name. The Bavarian, Baden, and Austrian locomotive engineers for many years preferred outside frames on the standard gauge,

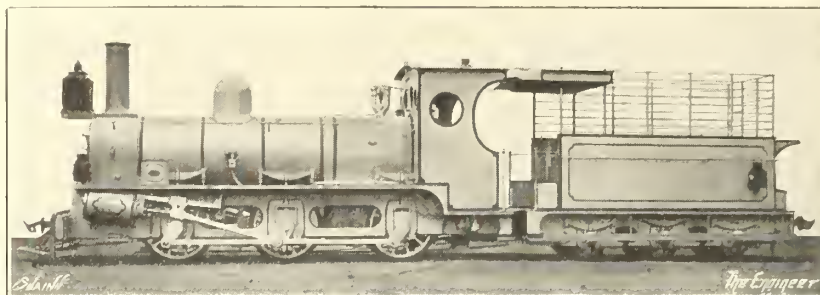

FIG. 304—INDIAN STATE RAILWAYS METRE GAUGE CLASS "F" ENGINE—VULCAN FOUNDRY, 1875-76

formed by the bosses of the driving wheels. Other features of these engines included Belpaire fire-boxes, underhung springs, and bogie wheels with solid centres. The springs of the coupled wheels were compensated.

The standard 4-4-0 engines—Fig. 306, "O" class—of the Indian State Railways from 1882 onwards had outside cylinders and single slide bars. The bogie wheel centres were lightened by means of holes. The engine illustrated was built by the Vulcan Foundry for the Bengal and North-Western Railway, and a very large number were built by this firm, and also by Neilson and Dübs.

Some 2-6-0 engines, "N" class, were built by Neilson in 1882-85 for the Southern Mahratta Railway. To enable the leading truck wheels to have sufficient lateral displacement, the cylinders were placed further from the frames than in the "F" class engines, and the connecting-rods were

even in combination with outside cylinders, and hundreds of engines were built with Hall's cranks, but they do not appear to have been made in this country until the Indian metre-gauge engines necessitated a similar combination to obtain a sufficiently wide fire-box and grate. None were ever used on British railways. The outside cranks were keyed to the axles and the outer surfaces of the crank bosses form the main bearings, which rotated within the axle-box brasses. The principal reason which induced Hall to invent the design was to bring the centres of outside cylinders closer to the framing, and for this purpose the frames were placed outside the wheels. In the case of six-coupled engines, the connecting-rods were on the outside of the coupling-rods, but in the case of most express engines the connecting-rods were inside. Heusinger v. Waldegg records that outside cylinder engines on South German rail-

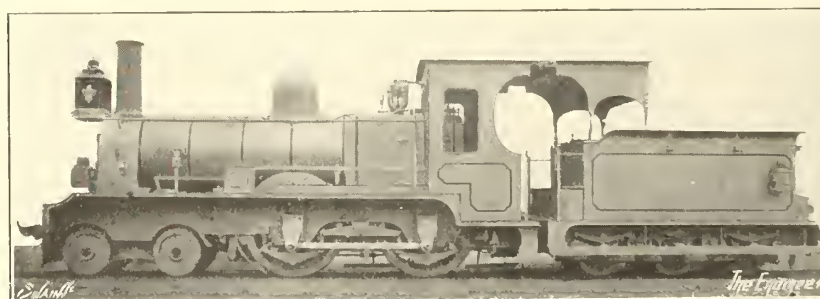

FIG. 395—METRE GAUGE ENGINE FOR THE RAJPUTANA-MALWA RLY.—DÜBS & CO., 1880

on the outside of the coupling-rods. This relative position of the rods was that used in the original Hall design in Bavaria. Only a few of this class were built.

Hall's Cranks.—Hall was an English engineer, who in the middle of the last century entered the

ways with Hall's arrangement of frames and cranks ran much more steadily than the ordinary engines with inside frames and outside cylinders partly as a result of the great width between spring centres. But the Union of German Railway Engineers in 1874, whilst admitting the above

advantage, recorded that on roads with severe curves there was a considerable number of breakages of the outside cranks and pins, and much more rapid wear of axle brasses, especially with increased loads. Similar casualties eventually occurred in India, and Sir Seymour Tritton—

“Proc.,” Inst. Mech. Eng., 1910, discussion on “Standardisation of Indian Locomotives”—stated that as traffic demands increased, “the mortality amongst these cranks was very great.” All the new metre-gauge standard engines have inside frames.

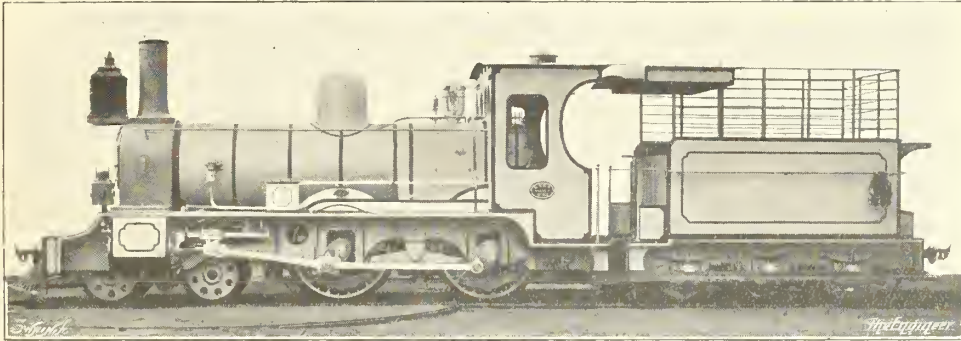

FIG. 306—INDIAN STATE RLYS., CLASS "O," AND BENGAL AND NORTH-WESTERN RLY. LOCOMOTIVE, BY VULCAN FOUNDRY, 1883

TABLE VII.

Fig. No.	Railway.	Gauge.	Cylinders.	Coupled wheels, dia.	Carrying wheels, dia.	Wheel base	Heating surface, square feet.		Grate area, sq. ft.	Pressure, lb. per sq. in.	Weight in working order.		
							Tubes.	Fire-box			Total.	On coupled wheels.	Total.
297	Great Southern & Western, Ireland	5' 3"	18" x 24"	4' 6½"	3' 8½"	Rigid, 13' 3" Total, 24' 9½"	900	84.5	18.8	140	t. 34 c. 8 q. 0	t. 46 c. 16 q. 0	0-6-4 tank 1320 gals.
298	Sligo, Leitrim & Northern Counties, Ireland	5' 3"	16½" x 20"	4' 9"	3' 0"	Rigid, 11' 0" Total, 23' 3"	896.5	75.8	14.9	130	26 16 0	42 19 0	0-6-4 tank 1200 gals.
—	Spain	5' 5¾"	18" x 24"	4' 0½"	—	4' 3" + 4' 3" + 5' 3"	1145	90.5	18.3	—	47 17 0	47 17 0	0-8-0 tank 900 gals.
—	Dutch State	4' 8½"	17½" x 24"	6' 0½"	3' 7"	6' 9" + 8' 4"	996.6	95.9	17.9	120	23 19 0	34 18 0	2-4-0
299	Dutch State	4' 8½"	18½" x 26"	7' 0"	4' 0"	9' 6" + 8' 6"	1221.9	102	23.4	150	26 19 2	39 0 1	2-4-0
—	Imperial Japan	3' 6"	12" x 18"	4' 3"	2' 9"	5' 5" + 7' 0"	508	57.2	9.0	120	—	18 10 0	2-4-0 tank 450 gals.
—	Imperial Japan	3' 6"	15" x 22"	4' 6"	2' 8"	5' 9" + 6' 6½" + 7' 7"	756	72	12.15	140	19 0 0	27 11 0	4-4-0
301	Natal Government	3' 6"	14" x 21"	3' 2"	2' 0"	Rigid, 7' 9" Total, 16' 8½"	611	58	11.0	140	22 16 0	29 16 0	4-6-0 tank

TABLE VIII.—Metre-gauge Engines, Indian Railways.

Fig. No.	Railway.	Type.	Cylinders.	Coupled wheels, dia.	Carrying wheels, dia.	Wheel base.	Heating surface, square feet.		Grate area, sq. ft.	Pressure, lbs. per sq. in.	Weight in working order.	
							Tubes.	Fire-box			Total.	On coupled wheels.
302	I.S.R., Class "A"	2-4-0 tank	19" x 18"	3' 6"	2' 3"	4' 6" + 5' 6"	330	31.5	5.4	120	t. 12 c. 9	t. 17 c. 13
—	North-West Provinces	0-4-2 tank	9" x 14" (inside)	2' 6"	2' 0"	6' 0" + 5' 0"	247.5	25.4	5.8	140	10 17½	13 15
303	I.S.R., Class "B"	0-4-4 tank	11" x 18"	3' 6"	2' 3"	5' 0" + 5' 5" + 4' 0"	384	43	7	140	12 19	21 14
—	South Indian	0-6-0	13" x 20"	3' 0"	3' 0"	5' 3" + 5' 9"	618.5	48	666.5	130	20 14	20 14
—	I.S.R., Class "E"	0-4-2	11½" x 17"	3' 0"	2' 1½"	5' 3" + 6' 0"	398.5	45.7	144.2	120	13 0	15 12½
304	I.S.R., Class "F"	0-6-0	14" x 20"	3' 6½"	3' 6½"	5' 3" + 5' 9"	590	58.2	648.2	140	21 2	21 2
—	South Indian, Class "G"	0-4-2	13" x 20"	4' 0"	3' 0"	5' 3" + 5' 9"	618.5	46.7	665.2	130	14 5	21 9
305	Rajputana-Malwa (B.B. & C.I.R.)	4-4-0	14" x 20" (inside)	4' 5"	2' 4½"	4' 0" + 5' 2" + 6' 0"	496	56	552	140	—	?
306	I.S.R., Class "O," and B. & N.W.R.	4-4-0	14" x 20"	4' 5"	2' 4½"	4' 0" + 5' 2" + 6' 0"	496.3	52.4	548.7	140	16 8	24 0
—	I.S.R., Class "N," Sdirm. Madhpratta.	2-6-0	14" x 20"	3' 0"	2' 1½"	5' 6" + 3' 3" + 3' 9"	512	57	569	140	18 7	22 4

Chapter XVIII—Compound Locomotives, 1882-89

THE period 1882-89 may, for convenience, be divided into two sections, of which this section deals only with compound locomotives. The contemporary non-compound engines follow in a subsequent section.

This, the first "compound era," is one of the most interesting in British locomotive history, and not only includes F. W. Webb's three-cylinder system and the two-cylinder engines of T. W. Worsdell, but also three examples of four-cylinder tandem compounds.

Webb's First Compound Locomotive.—In 1878 M. Mallet showed at the Paris Exhibition the first compound tank engine. It had one high-pressure and one low-pressure cylinder. F. W. Webb thereupon tried Mallet's system by converting in 1879 one of the Trevithick-Allan 2-2-2 engines with outside cylinders 15in. by 20in., lining up one of them and reducing it to 9in. diameter.

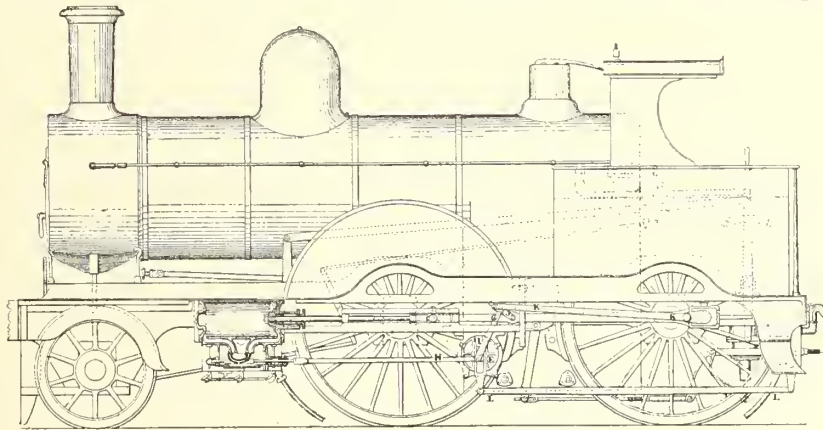

FIG. 307—F. W. WEBB'S L. & N.W.R. COMPOUND, 1882-83

These were the dimensions mentioned by him to the Institution of Mechanical Engineers in 1883, though in 1879 he gave the cylinder diameters as 9 $\frac{3}{4}$ in. and 15 $\frac{3}{4}$ in. This small engine worked light passenger trains on the Ashby and Nuneaton branch for about four years, "and the elements of success seen in its working" led to the adoption of the well-known three-cylinder compounds.

The Genesis of the Three-cylinder Compound.—Early in 1882 the first three-cylinder compound engine with two outside high-pressure cylinders and one central inside low-pressure cylinder was turned out from Crewe works. The high-pressure and low-pressure driving axles were uncoupled. It is worth noting that in the discussion on M. Mallet's paper before the Institution of Mechanical Engineers in 1879, Webb stated that "his idea was that to get a compound locomotive which would work steadily and economically at

high speeds it would be necessary to go back in form to the engine by R. Stephenson having three cylinders. . . . The boiler steam should be taken into the middle cylinder first, and thence into the outside cylinders, which should have their cranks in the same position and at right angles to that of the middle cylinder." Apart from his suggestion of copying Stephenson's arrangement of cranks, had Webb carried out his original idea of one high-pressure cylinder inside and two low-pressure cylinders outside, he might have produced a better engine than was actually adopted. Why he made the change and placed a large single low-pressure cylinder inside was never stated officially, as far as the writer is aware. But an interesting sidelight on the question was given by Mr. Edgar Worthington—in the discussion on his paper before the Institution of Civil Engineers in 1888—who suggested that, with a

single high-pressure cylinder "some disadvantage would probably arise from uneven pressure in the receiver, which would be replenished only twice, while it would be required to supply steam four times per revolution."

Webb's two main objects—according to his 1883 paper—in designing the first three-cylinder compound were, first, economy of fuel, and, secondly, the suppression of coupling-rods. No mention was made of lessened initial and final temperature differences in the high-pressure and low-pressure cylinders, or of the advantages to be gained by dividing the total power between two axles, and reducing the initial stresses on one driving axle.

The following four classes of express engines were built at Crewe from 1882 to 1890.

The "Experiment" of 1882.—Only one trial engine of this class was built, similar to Figs. 307 and 308. The outside high-pressure cylinders,

11½ in. diameter, drove the trailing axle, and the inside low-pressure cylinder, 26 in. diameter, the middle axle, the stroke being 24 in. in all three. The steam chests of the high-pressure cylinders were underneath to allow the valves, which were of the Trick type, to fall from their faces when steam was shut off; the low-pressure valve of the ordinary type was above the cylinder. The low-pressure ports were 14 in. by 1½ in. The 3 in. steam pipes B to the high-pressure cylinders were carried down the smoke-box and passed through the back plate carrying the low-pressure cylinder and thence between the inside and outside frames. The exhaust from the high-pressure cylinders was returned by two 4 in. pipes running parallel with the high-pressure steam pipes into the smoke-box, round the curved sides of which they were taken—as shown in Fig. 308—nearly to the top, each pipe passing across to the opposite side, where it entered the low-pressure steam chest. These pipes formed the receiver, in which the steam flowing

The leading axle of Webb's radial pattern had a lateral movement of 1¼ in. each side, and was placed well forward under the centre of the smoke-box, with its centre 9 ft. 4 in. in front of the middle driving axle, the latter being 8 ft. 3 in. from the trailing axle. This latter dimension was the same as that of the coupled wheel base of the "Precedents," as were also the diameters, 6 ft. 7½ in. of both driving and 3 ft. 7 in. of the leading wheels.

The "Experiment" ran for about twelve months, chiefly on the Irish mail trains between Euston and Crewe. It was certainly worked hard as regards mileage, being double-manned, though its trains were neither the fastest nor heaviest expresses.

The "Compound" Class of 1883-84.—The name "Compound" in this connection was that of the first engine of the class. The main difference between the new engines and the "Experiment" was the increase of the diameter

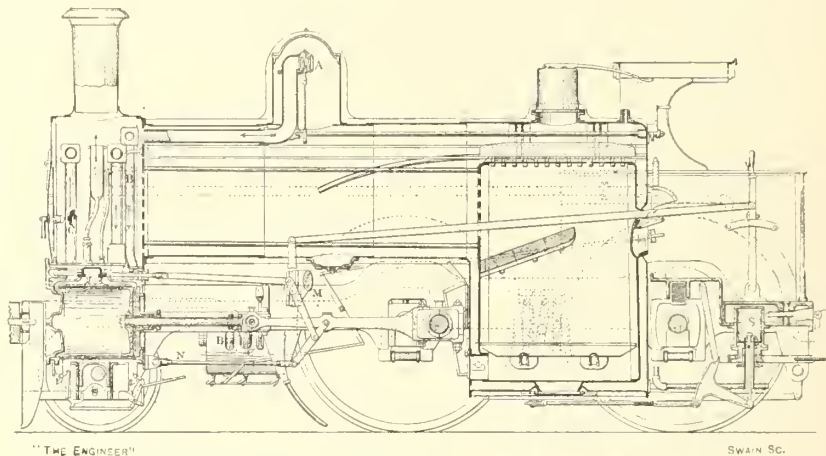

FIG. 308.—SECTIONAL ELEVATION OF L. & N.W. COMPOUND, 1882-83

between the high-pressure and low-pressure cylinders was re-heated by the waste gases. The final exhaust escaped from each side of the steam chest of the low-pressure cylinder into the blast pipe, which was 4½ in. diameter. There were, of course, only two beats per revolution. The Joy valve gear for the outside high-pressure cylinders differed slightly from that shown in Fig. 307, but the gear for the inside low-pressure cylinder was as shown in Fig. 308, and was of the standard Joy's design for inside cylinders, driven from the connecting-rod.

The boiler was of similar dimensions to that of the "Precedent" class, with 980 square feet of tube surface and 103.5 square feet of fire-box surface; total, 1083.5 square feet, but the pressure was raised to 150 lb. The water bottom of the fire-box will be noticed in Fig. 308; in these and the immediately succeeding engines it was not estimated as heating surface. The grate area was 17.1 square feet.

of the high-pressure cylinders from 11½ in. to 13 in., since it had been found that the "Experiment" did not possess sufficient starting power. The low-pressure cylinders remained 26 in. diameter as before, and the boiler and general dimensions were similar. Figs. 307 and 308 really represent the first series of the "Compound" class, and from Fig. 307 it will be noticed that the outside valve gear was somewhat unusual. The valve chests being below the cylinders, the motion discs E carrying the quadrant bars were placed in a corresponding position by securing them to the under side of the slide bars. The brass slide blocks I worked inside grooves in the quadrant bars, and were carried by the lifting links G, to the lower end of which the valve rod H was attached. To the upper end of the compensating link J was fastened. So far the arrangement was that of the usual Joy gear turned upside down, but instead of the radius rod N of the inside cylinder arrangement—Fig. 308—the

upper end of link J was controlled by a rod K—Fig. 307—attached to a return crank on the trailing crank pin.

Only a few of these engines were fitted with the return crank; the later engines were arranged with the upper end of the compensating link coupled to a radius rod of the usual form, which was attached to a fixed point in the frame in front, and subsequently all the engines were altered to this design, which was also the form of valve gear used in Webb's compound engines of the "Dreadnought" class, mentioned later.

The 13in. high-pressure cylinders of the "Compound" class had ports 9in. by $1\frac{1}{8}$ in. and $2\frac{1}{2}$ in.; travel of Trick valve, $3\frac{1}{8}$ in. in full forward gear; lap, $\frac{3}{4}$ in.; lead, $\frac{1}{8}$ in.; port opening, $\frac{3}{4}$ in.; maximum cut-off at 70 per cent. of the stroke. The 26in. low-pressure cylinders had ports 16in. by 2in. and $3\frac{1}{4}$ in.; travel of valve in full gear, $4\frac{1}{2}$ in.; lap, 1in.; lead, $\frac{3}{16}$ in.; maximum port opening, 1in.; cut-off in full gear at 75 per cent.; exhaust closure at 93 per cent. The reversing gears of the high-pressure and low-pressure cylinders were arranged to be worked independently. At that time Mr.

tributed as follows:—On leading wheels, 10.4 tons; on low-pressure driving wheels, 14.2 tons; on trailing high-pressure driving wheels, 13.15 tons. This weight was 4 tons greater than that of the "Precedent" class, which the "Compounds" were intended to replace, and as the boilers were of identical size, the difference represented weight of metal. Nevertheless, the "Compound" class could not do the work which the "Precedents" were doing, and the much larger and heavier "Dreadnoughts" were then built, whilst engines of the "Compound" class were relegated to lighter trains.

"Dreadnought" Class.—The first of this new class—Fig. 309—appeared in September, 1884, only one month after the last five of the previous class. In all there were 40 "Dreadnoughts," the last of which was turned out in June, 1888. The fourth engine, "Marchioness of Stafford," was shown at the Inventions Exhibition of 1885. The "City of Liverpool" was at the Liverpool Exhibition of 1886, in company with Stephenson's "Locomotion" and "Rocket."

The "Dreadnoughts" differed principally

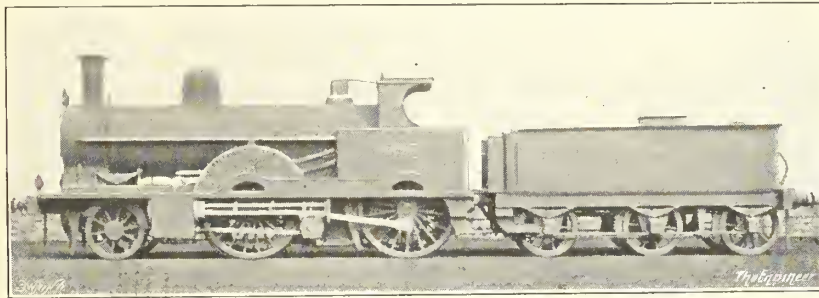

FIG. 309—"DREADNOUGHT" CLASS COMPOUND, L. & N.W.R., 1884-88

Webb stated that connecting the two involved extra complication without any material advantage. The degrees of expansion used in practice are referred to later.

The steam chest cover of the large cylinder was provided with a relief valve so adjusted that the pressure admitted could not exceed 75 lb. per square inch. An arrangement was also made whereby steam direct from the boiler could be admitted to the low-pressure cylinder. It does not appear that this valve was provided for the usual purpose of helping to start the engine, though there is no doubt that the drivers frequently tried to use it to that end. Mr. Webb stated that it was useful for warming up the cylinder. It was a "two-edged tool," the use of which frequently choked the receiver.

There were 29 engines of the "Compound" class, and since the "Experiment" was subsequently altered to have 13in. high-pressure cylinders and conform with the others, the total at the end of 1884 was 30.

The weight of these engines empty was $34\frac{3}{4}$ tons. In working order they weighed $37\frac{3}{4}$ tons, dis-

tributed as follows:—On leading wheels, 10.4 tons; on low-pressure driving wheels, 14.2 tons; on trailing high-pressure driving wheels, 13.15 tons. This weight was 4 tons greater than that of the "Precedent" class, which the "Compounds" were intended to replace, and as the boilers were of identical size, the difference represented weight of metal. Nevertheless, the "Compound" class could not do the work which the "Precedents" were doing, and the much larger and heavier "Dreadnoughts" were then built, whilst engines of the "Compound" class were relegated to lighter trains.

The "Dreadnoughts" differed principally from the preceding engines in their greatly enlarged dimensions, and, therefore, the old Crewe policy of comparatively light and cheap locomotives was completely discarded. There were a few differences in mechanical details, of which the following were the chief. The single low-pressure crank axle, which in the "Compound" class was forged with sloping crank cheeks, was replaced by a crank formed by bending the axle in a hydraulic press, so that the grain of the material followed the shape of the axle. The leading wheels were steel castings, but in the first engines of 1884-85, the driving wheels were of wrought iron. In 1886 steel castings were introduced for the large wheels. The leading axle was of Webb's radial type with $1\frac{1}{4}$ in. lateral movement on each side of the central position, but unlike that of the preceding engines, was placed in the usual position behind the smoke-box. The two Joy valve gears were the same as in the later "Compound" class, but the most important feature of all was the reversing gear, patented by Mr. Webb, so arranged that the high and low-pressure valve gears could be operated either

together or independently. This extremely ingenious arrangement was a credit to the Crewe drawing-office, but owing to the method of working the Webb three-cylinder engines in service, it proved unnecessary, as will be seen later.

The boiler pressure was raised to 175 lb. per square inch; diameter of the two high-pressure cylinders, 14in.; of the single low-pressure cylinder, 30in.; stroke of both, 24in.; driving wheels, 6ft. 3in. diameter; leading wheels, 3ft. 9in. diameter; wheel base, 8ft. 5in. + 9ft. 8in., advantage being taken of the absence of coupling-rods to obtain space for a long fire-box; boiler barrel, 11ft. long by 4ft. 1in. diameter inside the front or smallest ring; the 225 brass tubes, 1 $\frac{7}{8}$ in. diameter outside, provided 1242.4 square feet of heating surface; and the fire-box heating surface was officially given as 159.1 square feet; total, 1401.5; grate area, 20.5 square feet. Here it must be stated that the fire-box heating surface included the water bottom, which in the previous engines had very properly not counted as such. The sudden discovery of this additional "heating surface" has been mentioned in an earlier section,

and 15 tons on each of the two pairs of driving wheels.

After the first twenty "Dreadnoughts" had been in service some time, it was found necessary to improve the starting of the engines by the addition of a by-pass valve in the receiver pipe to allow the exhaust from the high-pressure cylinders to pass directly to the blast pipe, and relieve the back pressure on the high-pressure pistons. This valve, which was introduced in 1886, was under the control of the driver, and will be mentioned again in connection with the "Teutonic" class. The starting was certainly improved, but was still defective owing to the small size of the high-pressure cylinders.

"*Teutonic*" Class.—There were only ten of this class—Fig. 310—of which three came out in 1889, and seven in 1890. The cylinders, high-pressure 14in. by 24in., and low-pressure, 30in. by 24in., were of the same size as in the "Dreadnoughts," and the boilers were also similar. But the driving wheels were increased to 7ft. 1in., and the leading wheels to 4ft. 1 $\frac{1}{2}$ in. diameter. The writer has always understood that

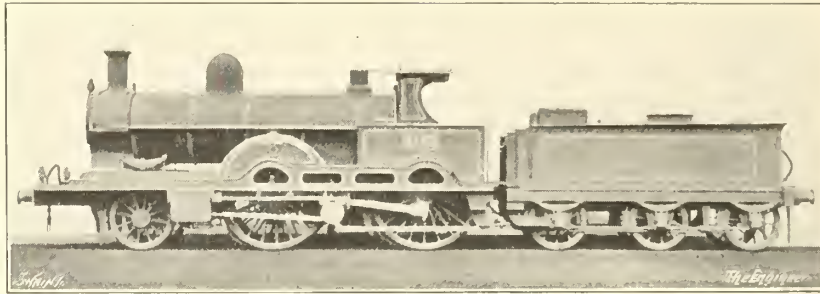

FIG. 310—"TEUTONIC" CLASS COMPOUND, L. & N.W.R., 1889-90

and looks like an attempt to add extra magnificence to the new engines. A calculation of the false surface below the level of the grate shows that it amounted to about 40 square feet, and if it be deducted the true fire-box heating surface becomes about 119 to 120 square feet, and the total heating surface to about 1362 square feet.

The ports of the high-pressure cylinders were 10in. by 1 $\frac{3}{8}$ in. and 2 $\frac{3}{4}$ in.; the travel of the Trick valves was 3 $\frac{1}{2}$ in. maximum; lap, $\frac{1}{2}$ in.; lead, $\frac{1}{8}$ in.; and inside clearance, $\frac{3}{16}$ in. The low-pressure ports were 18in. by 2in. and 4 $\frac{3}{4}$ in.; maximum travel of ordinary slide valves, 4 $\frac{1}{2}$ in.; lap, 1in.; lead, $\frac{3}{16}$ in.; inside clearance, $\frac{1}{4}$ in. The steam pipes to the 14in. high-pressure cylinders were 3in. diameter; and the exhaust (receiver) pipes, 5in. diameter. At the top of the smoke-box, behind the chimney, there was a relief valve connected to one of the receiver pipes, which limited the pressure in the low-pressure steam chest to 80 lb. per square inch. The weight of the engines empty was 39 $\frac{1}{2}$ tons, and in working order 42 $\frac{1}{2}$ tons, of which 12 $\frac{1}{2}$ tons were carried on the leading wheels,

the old wheel centres of McConnell's 7ft. "Bloomers" were used for these engines. The low-pressure cylinders of the second engine, "Oceanic," No. 1302, were 28in. diameter, when first built, and the third engine, "Pacific," No. 1303, was built as a "continuous expansion" engine, of which the cylinders, as published in *The Engineer*, were 14in., 14in. and 20in. diameter by 24in. stroke. It could be worked with boiler steam directly in all three cylinders for starting and on heavy gradients, or the steam could be expanded through all three cylinders.* This experiment was soon discarded, and the engine converted to the standard dimensions of the "Teutonic." Its doings as a continuous expansion engine were shrouded under an impenetrable silence.

* It would seem that if this engine was to be used as a continuous or triple-expansion engine, there must have been some error in the cylinder dimensions as given. But since the area of the two 14in. cylinders was practically equal to one 20in. cylinder, the original intention was probably to use boiler steam in all three cylinders.

The low-pressure pistons of the "Teutonics" were provided with tail rods, but they added to already excessive reciprocating masses, and were subsequently removed. There was also considerable overhang of the buffer beam, which, after the alteration, was brought back about 2ft. The drivers used to say that the engines ran better before the tail rods were removed.

The valve gears of the first two engines were as in the "Dreadnoughts," but the last seven engines of 1890 embodied a very important alteration, in that the Joy motion and the reversing gear for the inside low-pressure cylinder were entirely suppressed, and replaced by a single loose excentric, which drove the valve above the cylinder through the medium of a rocking shaft. The low-pressure cylinder was therefore always kept in full gear, and the driver could regulate the expansion only in the high-pressure cylinders. The loose excentric was driven by stops fixed in the left-hand side of the crank web, and reversal was effected automatically as the engine moved forward for half a revolution under the influence of the high-pressure pistons.

This new arrangement involved a modification. The bent crank axle of the "Dreadnoughts" was discarded and a built-up crank axle, with slab cheeks, into one of which the stops could be fixed, was substituted. These cheeks were extended backwards to form balance weights, an excellent improvement over balancing this axle in the rims of the wheels. It also necessitated the previously mentioned by-pass valve in the receiver pipe in the smoke-box, to allow the high-pressure exhaust to pass directly to the blast-pipe when starting, otherwise steam would have entered the low-pressure cylinder before the direction of motion had been reversed by the loose excentric. The by-pass valve was of a double-beat pattern controlled by the driver through a rod, pins and levers, and, like all valves in a smoke-box, was occasionally apt to stick. This defect resulted on a few occasions in one of the funniest phenomena which ever occurred in locomotive working. When the engine backed on to a train ready for a start the driver reversed the high-pressure gear, but the low-pressure excentric remained in back gear. If the rails were dry and the high-pressure driving wheels could move the engine forward a few feet to reverse the excentric, all went well, but if the rails were greasy, the high-pressure driving wheels spun round and filled the receiver with steam, which passed through the defective valve, and, if one of the low-pressure ports was open, into the low-pressure cylinder, with the result that the middle or low-pressure driving wheels began to slip round in the opposite direction. But in spite of this property, the loose excentric so simplified the gear that not only the "Teutonic" and all succeeding classes of three-cylinder compound engines were fitted with it, but many of the previous "Dread-

noughts" were also altered to have a similar arrangement.

The valve dimensions of the "Teutonics" differed somewhat from those of the "Dreadnoughts." The valves of the high-pressure cylinder had $3\frac{3}{4}$ in. full travel, or $\frac{1}{4}$ in. longer, the lap $\frac{5}{8}$ in., and lead $\frac{1}{8}$ in. remaining the same. The low-pressure valve had $5\frac{1}{2}$ in. full travel, or 1in. more than in the "Dreadnoughts." The lap remained 1in., but the lead was increased from $\frac{3}{16}$ in. to $\frac{1}{2}$ in. There was also a small amount of exhaust lap in place of the previous exhaust clearance, to provide extra cushioning in order to obviate, as far as possible, the uncomfortable surging action when starting, to which all the three-cylinder engines were liable.

The "Teutonic" class weighed $45\frac{1}{2}$ tons in working order, of which $14\frac{1}{2}$ tons were carried on the leading wheels, and $15\frac{1}{2}$ tons on each of the driving pairs.

It may be added that these ten engines were much the best of any of Webb's three-cylinder compound engines, and their performances will be referred to later. Meanwhile the various characteristics of the type, as a whole, and of the different classes in detail, form a most interesting study, and will now be briefly considered.

Advantages of Webb's Three-cylinder System.—The principal advantages were that the total power exerted by the engine was divided between two driving axles, and that the maximum straining actions were not only lessened in this manner, but still further decreased with regard to each axle by compounding. Much longer axle bearings were possible, though whether such long bearings were necessary with the greatly decreased straining actions is open to question on the grounds of added weight of axle-boxes. The bent crank axle of the "Dreadnought" class was a good feature, though it had to be discarded when the loose excentrics were adopted. Owing to the small size of the outside high-pressure cylinders and the central position of the large low-pressure cylinder, there was very little swaying or "nosing." The two driving axles could be placed far apart, thus allowing a very long fire-box to be used. At that time coupling-rods did not usually exceed 8ft. 6in. to 8ft. 9in. in length, though D. Drummond was using 9ft. rods. The two driving axles of the "Dreadnought" and "Teutonic" classes of compounds were 9ft. 8in. apart. A strong claim was made in that coupling-rods were avoided. Certainly their frictional resistance was absent, but this advantage was more than counterbalanced by other effects.

Cylinder Ratios and Receiver Capacity.—Webb tried three different values for the ratio of high-pressure to low-pressure cylinders. The first engine "Experiment" had a ratio of 2.55, but as the high-pressure cylinders, $11\frac{1}{2}$ in. diameter, were too small for starting the trains, in the succeeding "Compound" class the high-pressure

diameter was increased to 13in., and the resulting ratio decreased to 2. In the "Dreadnoughts" and "Teutonic" it was 2.3, but in later engines, again owing to starting difficulties, the high-pressure cylinders were further increased and the ratio again reduced to 2. But the ratio may be varied within fairly wide limits without materially affecting the total power of a compound engine, though a compromise is usual to equalise, as far as possible, the initial straining forces on the pistons and the work done in the high-pressure and low-pressure cylinders. The question of cut-off is dealt with later, but it may be mentioned here that a three or four-cylinder compound engine has the advantage over a two-cylinder compound with one driving axle in that equal division of work, though a desideratum, is not so essential.

The receiver capacity of the "Dreadnought" class was 1.58 times that of the two high-pressure cylinders. That of other classes was not stated.

Defects of Webb's Three-cylinder Compound System.—By dividing the high-pressure cylinder into two the diameter of each became too small for convenience in starting, unless the trains were light. Frequently only one high-pressure cylinder was open to steam, the other being on dead centre, and the ports of the low-pressure cylinder closed. In these circumstances it was obviously of no use to admit steam to the low-pressure steam chest, for when the high-pressure driving wheels slipped, as they almost invariably did, the high-pressure exhaust choked the receiver, until the valve on the latter blew off at 75 lb. or 80 lb. pressure and the back pressure on the high-pressure piston stopped the slipping. If the engine managed to move a few feet and the low-pressure cylinder became open to steam the receiver pressure diminished rapidly and the high-pressure engine started slipping again, and so on alternately. Gradually some sort of equilibrium was established and the train moved slowly away. Very frequently the engine had to back more than once, and in the early days of the "Compound" class of 1883-84 the assistance of four men with pinch bars was not unknown. After the by-pass valve had been introduced in 1886-87 and steam from the high-pressure cylinder could be exhausted directly to the blast-pipe, there was some improvement, though the starting was never really satisfactory. It was a serious defect, rendered worse by the use of uncoupled wheels.

The absence of coupling-rods brought about other evils. The high-pressure and low-pressure engines pulled the train alternately according as the crank effort exerted by one or other was momentarily greater. Coupling-rods would have enabled each engine to assist the other. With a single large low-pressure piston driving an uncoupled axle there was only the momentum of the whole engine and train to assist the low-pressure engine over dead centres. The writer does not know the exact weight of the low-pressure reciprocating masses, but an approximate calculation appears

to show that for the 30in. piston they would not be much less than about 750 lb. The "Dreadnought" had 6ft. 3in. wheels, and frequently had to run at 60 miles per hour in order to keep time. The value of $\frac{W w^2}{g}$ at this speed for 1ft.

crank radius is 18,470 lb., which, divided by the area of the 30in. piston, gives 26.1 lb. per square inch. At 45 miles per hour a diagram taken from one of these engines showed only 22 lb. per square inch initial steam pressure on the low-pressure piston, and if this pressure be assumed to be as great at 60 miles per hour, and the back pressure be taken at 6lb. per square inch—and it was often greater—there remained an effective pressure of only 16 lb. per square inch to start at the dead centres reciprocating masses which required 26 lb. per square inch. Consequently the low-pressure piston, throughout a portion of its stroke, was driven by its crank axle, which in turn had to be driven by the momentum stored in the engine and train.

To appreciate the effects of the points of cut-off employed in practice in these engines it should be borne in mind that with a late cut-off in the *high*-pressure cylinder there is a large increase of work done in the *low*-pressure cylinder, since the receiver pressure is much greater, but the proportion of the total work done in the high-pressure cylinder is reduced. This was the case immediately after starting, with the result that at slow speeds the low-pressure cylinder did most of the work. But since there was only one low-pressure cylinder, the linear curves of crank effort died away to zero at the ends of the stroke, and rose to a high peak in the middle. Therefore for a large portion of each semi-revolution the low-pressure engine exerted a big pull on the draw-bar in combination with the high-pressure engine, and for the remainder the high-pressure engine exerted a small one almost unaided. The effect was felt throughout the train, but more especially in the front coaches, as a violent surge, causing the passengers to rock backwards and forwards. This gradually died away as the train gathered speed, and at about 20 miles per hour ceased to be felt.

When Mr. Webb wrote the paper which was read before the Institution of Mechanical Engineers in 1883 there was only one engine, the "Experiment," which had seen more than a few weeks' service. In that paper the following pregnant sentence occurred:—"With regard to the degree of expansion at which the engine is worked, in practice the low-pressure cylinder is kept nearly in full gear, while all the expansion is done in the small high-pressure cylinders, so that no more steam is used than is absolutely necessary." The effect at high speed, when the cut-off in the high-pressure cylinders is early, is the converse of the above, and the high-pressure engine does the greater proportion of the work. The receiver pressure and consequently the initial pressure on

the low-pressure piston is low. Moreover, since the low-pressure cylinder was always kept in full gear, that is, with a constant cut-off of 70 per cent. in the "Compound" class, and 75 per cent. in the "Dreadnought" class, the receiver pressure was further reduced, owing to the heavy drain on its steam, and a big drop of pressure in the receiver took place, resulting in a loss, which was to some extent compensated by the reduction in the back pressure on the high-pressure pistons. The low-pressure curve of crank effort at high speeds had a comparatively low peak, and the work of running the train devolved to a greater degree on the independent high-pressure engine. Further, as mentioned above, the work of starting the large low-pressure reciprocating masses at the end of each stroke had also to be done by the momentum of the train. This was perhaps the greatest fault of Webb's system, to mitigate which neither engine could help the other directly.

The driver had the means, until the later engines with loose excentrics came out, of notching up the low-pressure gear and thereby lessening the receiver drop, but the effects of the increased back pressure on the high-pressure pistons and the greater initial pressure on a large 30in. low-pressure piston working an independent engine were detrimental. The drivers soon found from experience that trouble ensued when they notched up the low-pressure engine, though Mr. Webb was at first apparently loth to discard the double reversing gear. Eventually in 1890 he gave in and did away with all means of altering the low-pressure cut-off.

It has been mentioned that the "Teutonic" class with 7ft. 1in. wheels were much the best of all Webb's three-cylinder engines. They differed from the "Dreadnoughts" in two important variables, *viz.*, the much larger diameter of the driving wheels, and the valve dimensions, principally of the low-pressure cylinders. In regard to the latter the exhaust lap in place of the exhaust clearance was stated to be for the purpose of mitigating the fore-and-aft surging motion. As this motion took place at low speeds and was due to the uneven turning moments of the high-pressure and low-pressure engines, it is difficult to see the force of this argument, and the writer's experience was that the "Teutonics" were little better than the "Dreadnoughts" in this respect. But at high speeds the higher compression had the good effect of cushioning the heavy reciprocating masses. Further, the value of $\frac{W w^2 r}{g}$ at 60 miles per hour was reduced from, say, 26.1 lb. to 20.3 lb. per square inch of low-pressure piston area, as compared with the "Dreadnoughts," to the great advantage of the "Teutonic" class.

There was, in all probability, another reason why the "Teutonics" were better, to explain which the curves of crank effort—Fig. 311—have been drawn. These curves refer to the earlier

"Compound" class, with 13in. high-pressure and 26in. low-pressure cylinders, and have been drawn from indicator diagrams taken at a speed of 50 miles per hour, which were given in Mr. Webb's paper before the Institution of Mechanical Engineers, 1883. They must be considered as

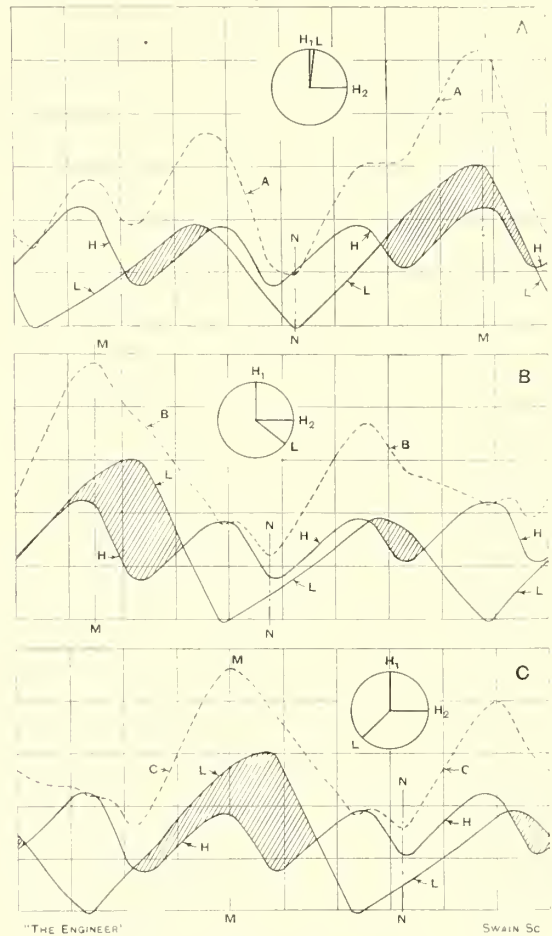

FIG. 311—CURVES OF CRANK EFFORT, L. & N.W.R. COMPOUND ENGINES

comparative, and not as exact, since the weights of the reciprocating masses could only be roughly calculated from the published general drawings. The difference in the heights of the low-pressure curve for the two strokes is due to the comparatively short ratio n of the low-pressure connecting-rod to crank length, which was about 5.75 to 1, so that the value of $1 + \frac{1}{n}$ for the out-stroke was 1.174, and that of $1 - \frac{1}{n}$ for the instroke .826.

These differences produced a big effect with a large 26in. piston and reciprocating masses. The ratio in the case of the high-pressure rod was about 8.5 to 1.

The low-pressure crank could take up any position relative to the high-pressure cranks. In

case A the highest peak of the low-pressure crank effort curve L has been placed immediately above the highest peak of the combined high-pressure curve H; in case B the highest peak of the low-pressure curve L lies immediately above the lowest trough of the combined high-pressure curve H; and in case C the low-pressure crank is 135 deg. from each of the high-pressure cranks. The shaded positions represent the parts of the stroke during which the low-pressure crank effort exceeds the high-pressure crank effort. It may be noted here that there is another case D, not shown, in which the low-pressure curve for this particular engine and speed rises above the high-pressure curve only once per revolution, when the low-pressure crank is nearly opposite the leading high-pressure crank. The dotted curves A, B and C show the combined crank efforts for the whole engine, which in cases A and B are much more irregular than in case C.

If the crank efforts be divided by the radius of the driving wheels, in this case 6ft. 7½in. diameter, the varying values of the tractive forces at the rails during one revolution are obtained as below:—

	Tractive force at tread of wheels.			
		Maximum, pounds.	Minimum, pounds.	Mean, pounds.
A. Maximum peak of L.P. curve coinciding with maximum peak of combined H.P. curve.	H.P.	2660	1200	1680
	L.P.	3620	—60	1450
	Total	6280	1140	3130
B. Maximum peak of L.P. curve coinciding with lowest trough of combined H.P. curve.	H.P.	2600	930	1680
	L.P.	3230	540	1450
	Total	5830	1470	3130
C. L.P. crank 135 deg. from either of cranks.	H.P.	2260	1300	1680
	L.P.	3320	600	1450
	Total	5580	1900	3130

The maxima and minima values are those calculated at M M and N N respectively, when the total combined crank efforts are greatest and least. At some position, probably in the vicinity of case C, the conditions are most favourable for even running, since the variations from the mean are the least.

It has always seemed to the writer that the engine, which when running could maintain the crank angles as in case C, would give the best results, and the ability to do this would depend first upon the high-pressure and low-pressure driving wheels being of the same diameter; and, secondly, upon the condition of the rails. When starting there was always more slipping of the high-pressure hind driving wheels than of the low-pressure wheels, and consequently their tires wore most. This effect would be felt to a greater extent with the smaller wheels of the "Dreadnought" class, and the two pairs of wheels in these engines were more liable to get out of phase than the larger wheels of the "Teutonic." It is possible, though

it remains to be proved, that all these compound engines, when once under way, automatically tried to adjust themselves to run in the most favourable position, such as case C. But it can certainly be stated that the 7ft. engines were much more even and reliable in their performances than those with 6ft. 3in. wheels, and the writer is of opinion that one of the main reasons for this difference is that they were not so liable to such extreme phase differences between the high-pressure and low-pressure engines.

Moreover, in both "Teutonic" and "Dreadnoughts," the whole 100 per cent. of the reciprocating masses of the low-pressure engine was balanced, and therefore the vertical centrifugal force of the balanced weight on top centre was very large. The adhesion of the low-pressure driving wheels at a speed of 65 miles per hour, when the weight was on top centre, was approximately 1.35 to 1 in favour of the "Teutonic," owing first to the smaller angular velocity of the larger wheels, and secondly to the ½-ton extra load on them. Slip through part of a revolution of the low-pressure wheels of the "Dreadnoughts" was more liable to occur when running.

There was also no definite phase relation between the exhausts from the high-pressure and the admission to the low-pressure cylinders. No diagrams taken from the low-pressure steam chest appear to have been published; and the amount of fluctuation of receiver pressure in practice, when running at high speeds with a 40 to 50 per cent. cut-off in the high-pressure cylinders, is unknown.

Performances of Webb's Three-cylinder Compounds.—When the first engine "Experiment" had been in service about twelve months, it was officially stated that it had worked the Irish Mail from Crewe to London, and the Limited Scotch Mail from London to Crewe on an average coal consumption per train mile of 26.6 lb. compared with 34.6 lb., the average of the "Precedent" class, "the boilers of the two engines being precisely the same." This quotation from Mr. Webb's statement takes no account of the 10 lb. higher pressure of the compound. But it was soon found that the "Compounds," to which the "Experiment," though with smaller high-pressure cylinders, belonged, could not keep time with the main line expresses and were therefore relegated to lighter trains, chiefly between Crewe and Holyhead, and Crewe and Manchester. Eight of the class on the London road, from a copy of a "Crewe" coal sheet, which the writer possesses, burnt 33½ lb. of best Welsh coal per mile. The loads were not given, but they certainly at that time—January, 1885—did not exceed an average of 11 six-wheeled coaches. On the Crewe and Holyhead road, including runs to Manchester, there were 13 engines, which averaged 31.4 lb. per mile with lighter trains at slower speeds. Two engines at Rugby, which worked heavier trains in the same link as the "Precedents,"

burnt 37.6 lb. per mile. They very often lost time with their trains, and would frequently drop two and three minutes on a 40-mile run at a booked speed of 48 to 50 miles per hour, with nine and ten coaches, without any signal slacks or other apparent cause than a rooted objection to running down hill. Apparently, on reaching about 55 to 58 miles per hour they generally remained at that, though there were rare instances of 61 or 62 miles per hour being attained for a mile or two.

The much more powerful "Dreadnoughts" superseded the above engines on the main line trains. For a few years they were worked extremely hard, running from Crewe to London, 158 miles, and back every day, with two sets of men, who worked on alternate days. In this respect Mr. Webb certainly did not spare the engines, though they were otherwise nursed and provided with the very best Welsh coal. Their performances on the road were what the writer ventures to term "streaky," that is, they sometimes made a good run, and at other times, by no means infrequently, did not. The following table, from one of the writer's note-books, illustrates his meaning:—

Engine No.	Run.	Miles.	Approx. load, tons.	Booked speed, m.p.h.	Actual speed, m.p.h.	Time gained + lost -
173	*Willesden to Northampton	60 $\frac{3}{4}$	110	50.3	51.6	+ 1 47
2064	Northampton to Bletchley	19 $\frac{1}{2}$	190	44.45	42.45	- 1 13
2058	Bletchley to Willesden	41 $\frac{3}{4}$	135	48.38	50.25	+ 1 53
1370	Blisworth to Bletchley	16 $\frac{3}{4}$	135	46.06	43.33	- 1 20
1370	Bletchley to Willesden	41 $\frac{3}{4}$	135	48.38	48.22	- 0 10
1353	Northampton to Willesden	60 $\frac{3}{4}$	100	51.74	49.56	- 3 5
503	Rugby to Crewe	75 $\frac{1}{2}$	155	47.0	48.2	+ 2 15

* Bad signal check, Bletchley.

The carriages in practically all cases were six-wheeled, with the exception of the last run from Rugby to Crewe, when there were five eight-wheeled and five six-wheeled vehicles.

In later years the "Dreadnoughts" improved. Rous-Marten once timed No. 643, "Raven," with the down Scotch express and 190 tons, practically all eight-wheeled stock, from Willesden to Rugby, 77 miles in 85 min. 20 sec., of which 2 min. were lost owing to a bad signal check. Starting from Rugby, Stafford, 50 $\frac{3}{4}$ miles, was passed in 53 min. 9 sec., and Crewe, 75 $\frac{1}{2}$ miles, was reached in 78 min. 56 sec., in spite of a slight check at Betley. If the net time be taken at 77 min., the average speed was about 58.6 miles per hour, with a maximum of 72 miles per hour down the Whitmore bank. With engine 511, "Achilles," the 90 $\frac{1}{2}$ -mile run from Preston to Carlisle was done in 100 min. 3 sec., with a load of about 160 tons. The distance of 58 $\frac{1}{2}$ miles from the Preston start

to Shap Summit, including the ascent of the Grayrigg and Shap banks, was covered in 69 min. 22 sec. These were the best of a series of actual runs, and though the same authority had a number of other good records with these engines, he also had, as he informed the writer, some very inferior runs.

The coal consumption of the forty engines, as given officially, averaged 37.7 lb. per mile for a mileage varying from 210,000 to 340,000, mostly on the main line between London and Carlisle, but the loads were not stated.

The "Teutonics" with 7ft. wheels were much more reliable, and several of them did really good work during their career. They were lighter on fuel than the "Dreadnoughts" and averaged 35 lb. per mile at distinctly higher speeds. The record of the "Jeanie Deans," No. 1304, was officially given as 32.4 lb. per mile during the first 193,500 miles. From January, 1891, until August, 1899, this engine worked the 2 p.m. Scotch dining car express from Euston to Crewe, returning with the corresponding up train. The usual load varied from about 250 to 300 tons, and good time was generally maintained. The down train was timed at a rate of just under 50 miles per hour, and the faster up train at 52.3 miles per hour. With the former and a load of 256 tons the run from Willesden to Rugby, 77 $\frac{1}{4}$ miles, was done in 91 $\frac{1}{2}$ min., or 1 $\frac{1}{2}$ min. under time. The maximum downhill speed was only 67.1 miles per hour for a single mile, but on the uphill climb to Tring at 1 in 330 the speed did not fall below 42 $\frac{1}{2}$ miles per hour. The best recorded performance on the up train was a run from Nuneaton to Willesden, 91 $\frac{1}{2}$ miles, in 101 $\frac{3}{4}$ min. with a very heavy load of 263 tons.

An equally famous engine of the "Teutonic" class was No. 1309, "Adriatic," perhaps the best of all Webb's three-cylinder compounds. This engine was often employed on the 1895 racing train to Scotland (8 p.m. from Euston) which had been lightened to four eight-wheeled coaches and one six-wheeled van. From Euston to Stafford, where a special stop for water had to be made owing to one of the water troughs being out of order, the time for the 133 $\frac{1}{2}$ miles was 127 min., at a rate of 63 $\frac{1}{4}$ miles per hour. Particulars of this run were given in *The Engineer* of August 30th, 1895. The same engine ran from Crewe to Rugby with a train weighing 170 tons at an average speed of 56.2 miles per hour. The coal consumption of the "Adriatic" during a mileage of 220,000 to 1894 was, according to the official figures, only 31.3 lb. per mile. No. 1306, "Ionic," ran 708,546 miles to the end of September, 1904. Nevertheless, there must have been an unpublished "something" in connection with all the three-cylinder compound engines, for very shortly after G. Whale, who had had the engines under his charge as running superintendent, succeeded F. W. Webb, he immediately proceeded to scrap

the lot, including even the "Teutonic" class. Between 1903 and 1907 all Webb's three-cylinder compounds disappeared.

Compound Tank Engines.—During 1884-87 four three-cylinder tank engines were built at Crewe. The first, Fig. 312, was reconstructed in

it indulged in and communicated to the train the peculiar fore-and-aft surging movement to a superlative degree, thereby earning for itself more unpopularity with the travelling public than probably any locomotive ever built. Possibly as a result of this experience the third engine—Fig.

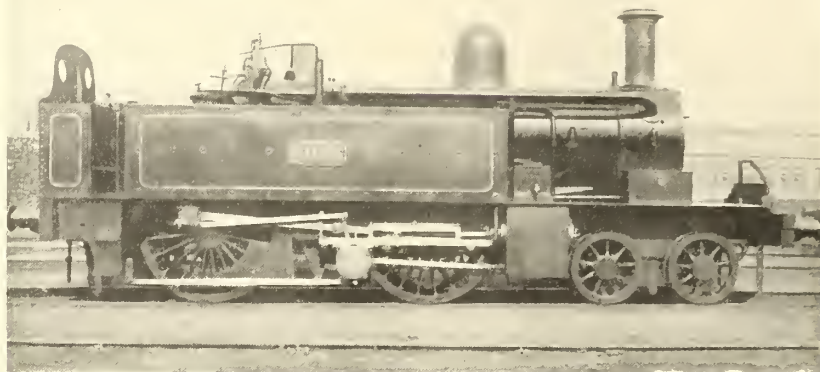

FIG. 312—L. & N.W.R. COMPOUND TANK ENGINE, 1884 [Photo. Locomotive]

1884 from one of Beyer, Peacock's "Metropolitan" type tank engines, and retained the leading bogie. The cylinders were:—High-pressure, 13in. by 24in.; low-pressure, 26in. by 24in.; driving wheels, 5ft. 9in. diameter; total wheel base, 18ft. 2in.; centres of driving axles, 8ft. 10in.; total heating surface, 1028.4 square feet; pressure, 150 lb.; weight in working order: on bogie, 11 tons 7 cwt.; on low-pressure front driving wheels, 18 tons 1 cwt.; on high-pressure hind driving wheels, 17 tons 9 cwt.; total, 46 tons 17 cwt.

The second engine of 1885 and the third engine of 1887 were of an eight-wheeled type with leading and trailing radial axles, but of very different dimensions. Fig. 313 shows the third and larger engine.

The 1885 engine was an attempt to produce an engine practically equivalent to the small standard 2-4-2 tank engines with 4ft. 8½in. wheels. The outside high-pressure cylinders were 14in. diameter by 18in. stroke, and the inside low-pressure cylinder was 26in. diameter by 24in. stroke; total wheel base, 21ft. 3in.; total heating surface, 994 square feet; grate area, 14.2 square feet; pressure, 160 lb.; total weight, 50 tons 17 cwt., of which each pair of driving wheels carried approximately 15½ tons; weight empty, 41 tons 11 cwt. The stroke of the two high-pressure cylinders was less than that of the low-pressure cylinder, and the ratio of cylinder volumes was 2.3 to 1, as in the "Dreadnoughts."

This engine was announced as a "Patent Engine for Suburban Work," and had not been in the London area a week before it had thoroughly earned the title. It was employed on the Broadstreet and Mansion House service, and, when making each of the many starts from the stations,

313—built in 1887, had larger wheels, 5ft. 9½in. diameter. The high-pressure cylinders were 14in. by 20in., the low-pressure cylinders remaining 26in. by 24in. as before; cylinder ratio 2.07. The wheel base was increased to 21ft. 8in. The boiler was similar to that of the preceding engine, having 160 lb. pressure, and the total weight became 52 tons in working order.

The fourth engine—Fig. 314—was termed and intended to be a goods tank engine, but instead of coupling all three axles, Mr. Webb preferred to adhere to his original patent, and produced an engine with an uncoupled low-pressure axle independent of the high-pressure axle, the latter being coupled to the trailing axle only. The two outside cylinders were 14in. by 24in. for the high



FIG. 313—L. & N.W.R. COMPOUND TANK ENGINE, 1887

pressure, and one inside 30in. by 24in. for the low pressure; driving wheels, 5ft. 2½in.; wheel base, 21ft. 6in.; the small leading wheels, 3ft. 9in. diameter, being provided with radial axle-boxes; total heating surface, 1098.9 square feet; pressure, 160 lb.; weight in working order, 55 tons distributed as follows:—Leading radial wheels, 12 tons 15 cwt.; low-pressure driving wheels, 15 tons;

high-pressure driving wheels, 13 tons 16 cwt.; trailing coupled wheels, 13 tons 9 cwt.

Whether the performances of this engine, which was shown at the Manchester Exhibition of 1887, were satisfactory on goods trains, seems doubtful,

The two-cylinder compound engine was introduced by Anatole Mallet on the Bayonne and Biarritz Railway in 1876. It was afterwards taken up in Germany by Schichau and von Borries, and introduced on a large scale into this country in



FIG. 314—L. & N.W.R. COMPOUND GOODS TANK ENGINE, 1887 (Photo. Locomotive)

for not long afterwards it appeared on the Manchester and Buxton passenger train services, on which it remained for some years.

Even Mr. Webb was apparently not satisfied with his system for tank engines; not only did he cease further construction, but as soon as the boilers of the four engines described were worn out, he himself scrapped the engines in 1897-1901.

Two-cylinder Compound Express Engines.—These engines are of the cross-compound type, with cranks at 90 deg. on the same driving axle, and it is essential that the work done in the two cylinders shall be as nearly as possible equal at all points of

1884 by T. W. Worsdell on the Great Eastern Railway. The difference between the various systems lay principally in the designs of starting valves, which had to be employed to admit boiler steam to the low-pressure cylinder.

The object in Worsdell's engines was, firstly, the gain of thermal efficiency, resulting in economy of fuel, and, secondly, to decrease the maximum stresses on the working parts, but at the same time to retain simplicity by keeping to the two-cylinder engine without other material deviation than the increased size of the low-pressure cylinder, and the additional starting valve.

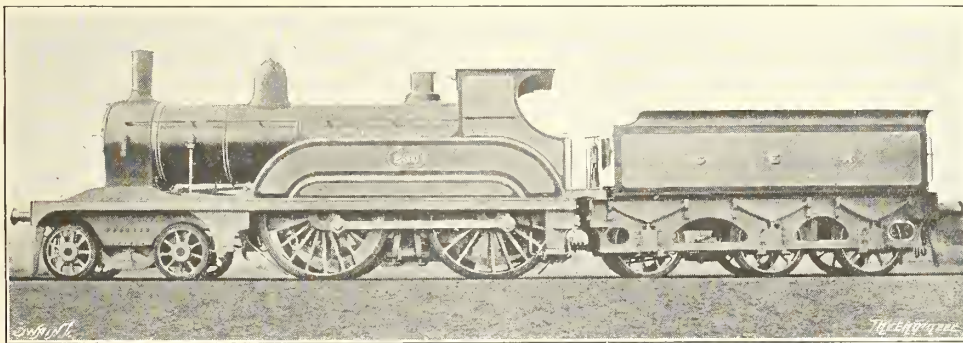

FIG. 315—T. W. WORSDELL'S COMPOUND EXPRESS ENGINE, G.E. RLY., 1884

cut-off within the usual working range of the engine. There can therefore be no such method of working, forced upon Webb, as always cutting off at full gear in the low-pressure cylinder, whilst varying the cut-off in the high-pressure cylinders.

In 1882-83 T. W. Worsdell constructed 20 simple 2-4-0 express engines for the G.E.R., described subsequently, which had 7ft. coupled wheels, 18in. by 24in. cylinders, 140 lb. pressure, and Joy's valve gear. For the compound engine,

he took this design, made one of the cylinders 26in. diameter, and substituted a bogie for the existing single axle, producing the engine shown in Fig. 315. The boiler pressure was raised to 160 lb.; the 18in. by 24in. high-pressure cylinder had ports 11 $\frac{3}{4}$ in. by 1 $\frac{3}{4}$ in. and 3 $\frac{1}{2}$ in., and those of the 26in. by 24in. low-pressure cylinder were 14in. by 2in. and 3 $\frac{1}{2}$ in. The steam lap, 1 $\frac{1}{8}$ in.; maximum travel, 5in., and lead $\frac{3}{16}$ in., were the same for both cylinders. The latter were spaced at 2ft. centres. The bogie wheels were 3ft., and the coupled wheels 7ft. diameter; wheel base, 6ft. 3in. + 7ft. 7 $\frac{1}{2}$ in. + 8ft. 9in.; fire-box heating surface, 117.5 square feet; total, 1200 square feet; grate, 17.3 square feet; weight on bogie, 14 tons 15 cwt. 2 quarters, on driving wheels 14 tons 16 cwt. 2 quarters, on trailing wheels 14 tons 18 cwt.; total 44 tons 10 cwt. in working order; weight empty, 41 tons 2 cwt. 3 quarters.

The slide valves were placed above the cylinders, and the high-pressure cylinder was on the

arrangement in *The Engineer* of February 25th, 1887, to which reference may be made.

There were eleven of these engines, concerning which James Holden, who succeeded T. W. Worsdell on the Great Eastern Railway, stated that when worked at a pressure of 160 lb., they saved 14 per cent. of fuel, as compared with sister non-compound engines, but that when the pressure had to be reduced to 150 lb., the saving was reduced to 2 per cent. only. The engines steamed well, though the diameter of blast-pipe was 80 per cent. larger than in the non-compound engines.

In 1886 Mr. Worsdell, who had become chief locomotive superintendent of the North-Eastern Railway, built a two-cylinder 2-4-0 compound express engine at Gateshead works, followed in 1887 by ten similar engines, the latter with leading bogies—Fig. 316. Although the general design, including Joy's valve gear and the starting and intercepting valves, was similar to that of the Great Eastern engines, there were two important

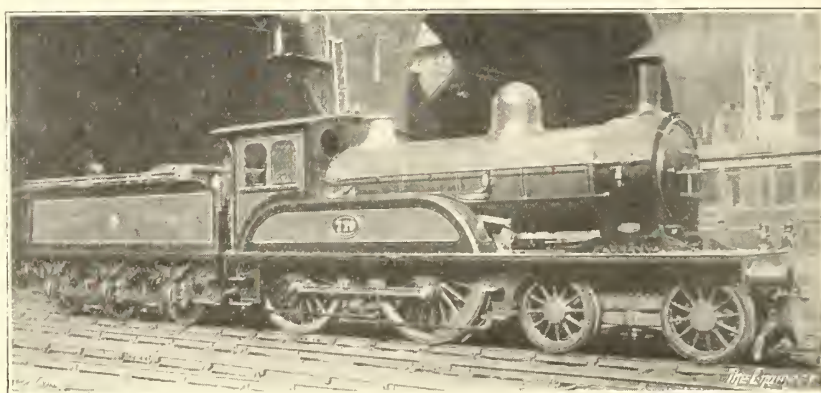

FIG. 316—I. W. WORSDELL'S COMPOUND ENGINE, N.E.R., 1887

left-hand side. The exhaust steam from the latter entered a receiver pipe, 6in. diameter, which passed round the interior of the smoke-box. When the engine was new, the starting arrangement consisted simply of a valve whereby boiler steam could be admitted to the low-pressure cylinder, but this steam immediately travelled round to the exhaust side of the high-pressure cylinder and blocked the piston, so that about once in ten times the engine failed to start, as Mr. Worsdell himself stated. To obviate this, an intercepting flap valve worked from the footplate was placed in the receiver pipe, and was closed by the driver before the starting valve was opened. As the engine moved, the first exhaust from the high-pressure cylinder automatically opened the valve, and allowed this steam to pass directly to the low-pressure cylinder. This arrangement, which differed in detail, though it was similar in principle, from that subsequently used on the North-Eastern Railway, was illustrated in *The Engineer* of May 15th, 1885, and the later

differences. The boiler pressure was raised to 170 lb., and in order to secure as nearly as possible equality of work in the two cylinders, there was a differential adjustment of the quadrants of the Joy gear to give a later cut-off in the low-pressure than in the high-pressure cylinder. The latter was 18in. diameter, and the former 26in. diameter, the common stroke being 24in.; cylinder ratio, 1:2.09. Von Borries estimated that to produce equal amounts of work in both cylinders with ordinary valve gear without differential adjustment, the ratio should be 1:2.25 to 1:2.3, but this caused the low-pressure cylinder to be of inconvenient size. The high-pressure cylinder had ports 11 $\frac{3}{4}$ in. by 1 $\frac{3}{4}$ in. and 3 $\frac{1}{2}$ in.; steam lap of Trick double ported valve, 1 $\frac{1}{8}$ in.; maximum valve travel, 4 $\frac{1}{4}$ in.; lead, $\frac{3}{16}$ in. The low-pressure cylinder ports were 17in. by 2in. and 3 $\frac{1}{2}$ in.; steam lap of valve, $\frac{15}{16}$ in.; maximum travel, 5 $\frac{1}{4}$ in.; lead, $\frac{3}{8}$ in.; and exhaust clearance, $\frac{1}{8}$ in. The cylinders were spaced at 2ft. centres. With a cut-off of 70 per cent. in the high-pressure cylinder, the cut-off in the low-

pressure cylinder was $84\frac{1}{2}$ per cent.; at 50 per cent. high-pressure cut-off, the low-pressure cut-off was 73 per cent. The starting and intercepting valves were operated by one handle, instead of two, as in the earlier G.E.R. compound engines. Two spring-loaded valves were fitted on the ends of the low-pressure cylinder, pressed to 100 lb. per square inch. The coupled wheels of both engines were 6ft. $8\frac{1}{4}$ in. diameter; the leading wheels of the 2-4-0, 4ft. $7\frac{1}{4}$ in. diameter; and the bogie wheels of the 4-4-0, 3ft. $7\frac{1}{4}$ in. diameter. The former had a wheel base of 7ft. 9in. + 8ft. 8in., that of the 4-4-0 engine being 6ft. 6in. + 6ft. 9in. + 8ft. 8in. The boilers of both classes were alike, 4ft. 6in. diameter outside, and contained 242 brass tubes, $1\frac{3}{4}$ in. diameter; fire-box heating surface, 112 square feet; total, 1323.3 square feet; grate area, 17.33 square feet. The 4-4-0 and all later express engines with bogies had

remained as in the 4-4-0 engines. The steam lap of the low-pressure valves was increased from $\frac{15}{16}$ in. to $1\frac{1}{8}$ in., the lead reduced from $\frac{3}{8}$ in. to $\frac{3}{16}$ in.; the travel in full gear $5\frac{1}{4}$ in., and the inside clearance $\frac{1}{8}$ in. remaining as before.

In 1889-90 ten much larger compound single engines were built at Gateshead, with large driving wheels, 7ft. $7\frac{1}{4}$ in. diameter. The high-pressure cylinder was 20in. by 24in., and the low-pressure 28in. by 24in. To get the cylinders in between the frames, which were 4ft. apart inside, they were arranged at 2ft. centres—as shown in the cross-section, Fig. 318—with the steam chests outside, the valves being actuated by Joy's gear and rocking shafts. The centre line of the high-pressure cylinder was inclined upwards and that of the low-pressure downwards towards the driving axle. The ports of the high-pressure cylinders were 17in. by $1\frac{3}{4}$ in. and $3\frac{1}{2}$ in.; lap of valves,

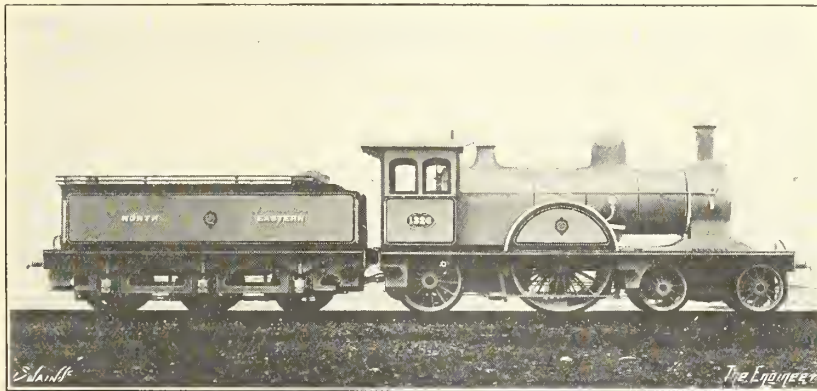

FIG. 317—T. W. WORSDELL'S COMPOUND ENGINE, N.E.R., 1888

low-pressure piston tail rods. The weights were:—

	2-4-0.			4-4-0.		
	t.	c.	q.	t.	c.	q.
Leading wheels or bogie ...	12	18	0	15	10	3
Driving wheels ...	17	19	0	17	7	1
Trailing wheels ...	12	9	3	14	13	0
Total in working order ...	43	6	3	47	11	0
Total empty ...	40	10	0	—	—	—

In 1888-90 ten 4-2-2 compound engines—Fig. 317—were built during a period when “single” engines had again come into favour for express work. The cylinders were 18in. and 26in. by 24in.; diameter of driving wheels, 7ft. $1\frac{1}{4}$ in. Owing to the size of the latter, the boiler was only 4ft. 3in. diameter, pitched with centre 7ft. 8in. above the rails; total heating surface, 1136 square feet, of which the fire-box provided 110 square feet; grate area, 17.2 square feet; pressure, 175 lb. Weight in working order, on bogie 14 tons 12 cwt., on driving wheels 18 tons, on trailing wheels 10 tons 5 cwt. 2 qr., total 42 tons 17 cwt. 2 qr.; weight empty, 39 tons 11 cwt. The wheel base was the same as that of the 4-4-0 engines described above. The high-pressure valves had an inside clearance of $\frac{1}{4}$ in., but in other respects

$1\frac{1}{8}$ in.; lead, $\frac{3}{16}$ in.; maximum travel, $4\frac{3}{8}$ in.; inside clearance, $\frac{1}{8}$ in. The low-pressure cylinder had ports 20in. by 2in. and $3\frac{1}{2}$ in.; outside lap, $1\frac{1}{8}$ in.; lead, $\frac{3}{16}$ in.; maximum travel, $5\frac{3}{8}$ in.; and inside clearance $\frac{1}{8}$ in. The trailing wheels were 4ft. $7\frac{1}{4}$ in. diameter, and the wheel base was the same as that of the preceding engines. The tube heating surface was 1016 square feet; fire-box, 123 square feet; total, 1139 square feet; grate area, 20.7 square feet; pressure, 175 lb. Weight in working order, on bogie 15 tons 18 cwt. 2 qr., on driving 17 tons 15 cwt., on trailing 13 tons, total 46 tons 13 cwt. 2 qr.; weight empty, 44 tons 3 cwt.

Before leaving the subject of compound express engines, it may be added that W. Adams, on the L. and S.W.R., in February, 1888, converted a 4-4-0 engine, with 7ft. coupled wheels and 18in. by 24in. outside cylinders, by replacing one of the latter by a low-pressure cylinder 26in. diameter. This large outside cylinder was rendered possible owing to the large size of the driving wheels, and the position of the connecting-rods inside the coupling-rods. The cylinder centres remained 6ft. $1\frac{1}{2}$ in. apart, and a larger hole was cut in the frames. The boiler pressure remained 160 lb. as

before, and the Stephenson link motion was modified to give increased valve travel, though whether it was arranged for a later cut-off in the

ders. This engine ran for three years as a compound engine, and was then reconverted to a simple engine.

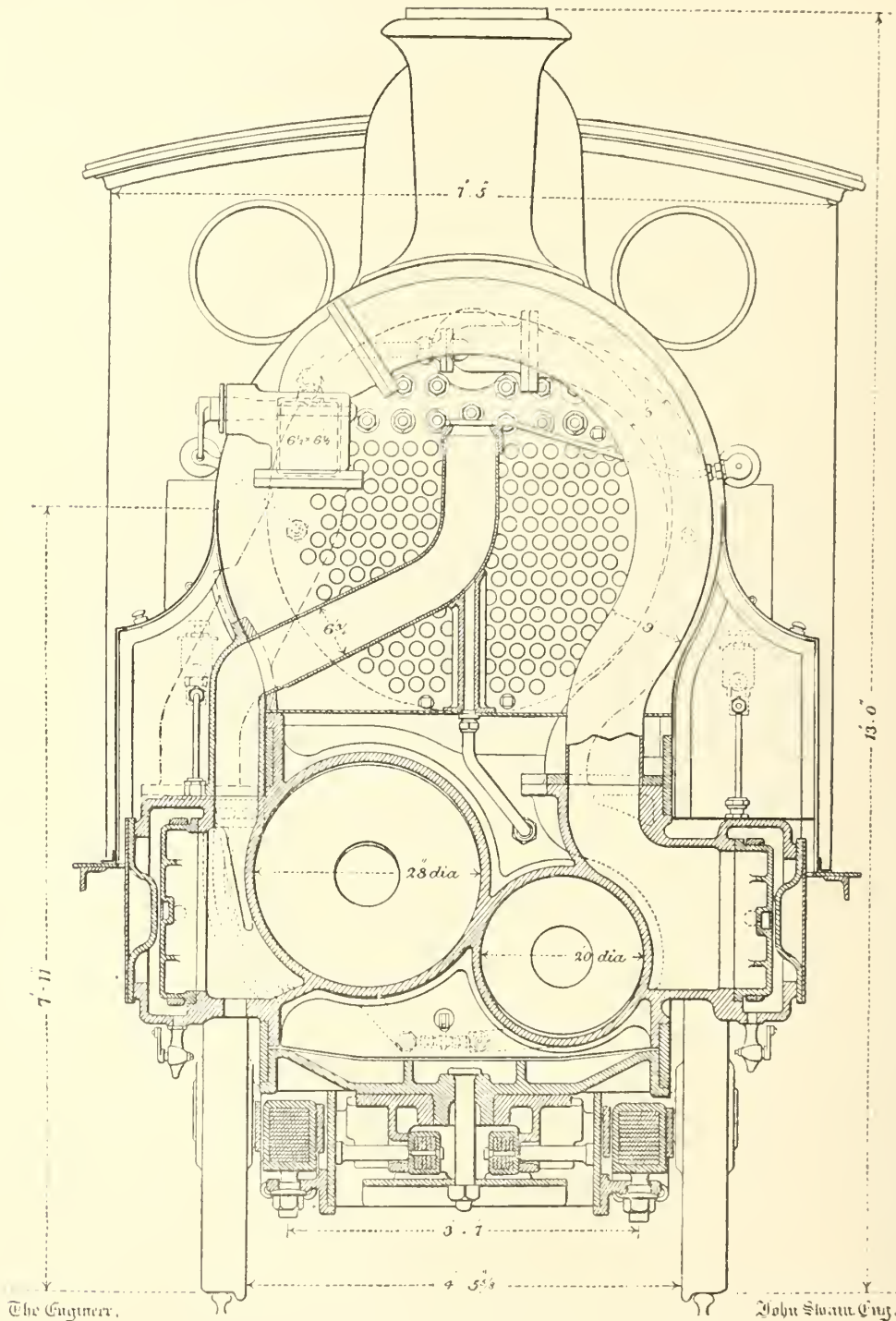

FIG. 318—CROSS SECTION OF N.E.R. COMPOUND ENGINE, 1889

low-pressure than in the high-pressure cylinders was not stated. Double inlet Trick valves were used in both high-pressure and low-pressure cylin-

Compound Goods Engines with Two Cylinders.—In 1886 T. W. Worsdell, on the North-Eastern Railway, built the first six-wheels coupled com-

pound goods engine to work in this country. As in his contemporary passenger engines, the cylinders, inside, were 18in. and 26in. diameter by 24in. stroke. The ports and valves were also similar except that the maximum valve travel was 5½in. The differential arrangement of the valve gear was such that in full forward gear the high-pressure cut-off was 73 per cent., and the low-pressure 86 per cent. With a 50 per cent. high-pressure cut-off, the low-pressure cut-off was 73 per cent. The coupled wheels were 5ft. 1¼in. diameter, and the wheel base 8ft. + 8ft. 6in.; the boiler, with 1136 square feet of total heating surface and 17.2 square feet of grate area, was similar to that of the first 4-2-2 express engines—Fig. 317—but carried 160 lb. pressure. Weight in working order, leading 14 tons 3 cwt. 2 qr., driving 15 tons 10 cwt., trailing 12 tons 3 cwt., total 41 tons 16 cwt. 2 qr.; weight empty, 39 tons 6 cwt. 2 qr. One hundred and seventy-one of these engines were built from 1886 to 1892, and

from 1890 onwards and are considered subsequently.

The Two-cylinder Compound System.—Before discussing the two-cylinder compounds, it should be stated that T. W. Worsdell's North-Eastern engines did some very good work in their day. But their day was that of the past generation when locomotives of medium power were sufficient for the general needs of British railways, and however great their success then it would have availed nothing at the present time, owing to the fatal limitations in lateral dimensions between the frames for inside cylinders, and of the restricted British structural gauge when the necessity for outside cylinders had been reached.

Worsdell's compound engines were considerably simpler and cheaper to construct than Webb's three-cylinder type, and, within the writer's experience, their performances on the road were more reliable.

It is difficult to compare the coal consumption of



FIG. 319.—T. W. WORSDELL'S COMPOUND GOODS ENGINE, N. E. R. L., 1886-92

one of them is shown by Fig. 319. The last engines of 1892 had piston tail rods.

Similar compound engines, but arranged as 0-6-2 tank engines, were also built for the purpose of working coal trains in the Newcastle and Durham areas. Fig. 320 illustrates one of these tank engines.

James Holden, on the Great Eastern Railway, built one 0-6-0 two-cylinder compound goods tender engine at Stratford works in 1887 with cylinders 18in. and 26in. diameter by 24in. stroke, and 4ft. 10in. wheels—Fig. 321. It was a modification of the standard goods engines on that line, and had Stephenson's link motion, but from the diagrams it appeared that the cut-off in both cylinders took place at the same point of the strokes. Both high and low-pressure valves had ¼in. inside clearance.

A number of two-cylinder compound engines with v. Borries starting valves were built by Beyer, Peacock and Co. for Irish railways. They dated

engines on different railways, but, as far as can be judged, Worsdell's engines were considerably superior in this respect, in spite of the fact that they did not burn best Welsh coal.

The published indicator diagrams, such as those given in *The Engineer* of March 7th, 1890, relating to the large single express engines with 20in. and 28in. by 24in. cylinders, show that the work was as evenly divided between the two cylinders as could be expected, the differences between the indicated horse-powers developed at high speeds varying from about 18 to 52, the greater power being always on the high-pressure side. Whether such even distribution was attained at all times in service is doubtful, and, if not, there would be a tendency to "run sideways," more especially in the case of express engines. The experience on the German railways with two-cylinder compounds, extending over many years, proved that equally good division of work between the cylinders could not be attained under conditions varying from

slow speeds at full boiler pressure to high speeds, but it was also stated that a difference not exceeding 15 per cent. had no bad influence on the running of the engine. The speeds were, however, considerably lower than in this country.

The differential arrangement of valve gear to

engines which worked either chimney or bunker end first were simple engines, and he never built any compounds for such service. Some two-cylinder compound passenger tank engines were built by Beyer, Peacock and Co. for Irish railways at a later date.



FIG. 320—T. W. WORSDELL'S COMPOUND GOODS TANK ENGINE, N.E.R., 1888

cut-off about 20 per cent. later in the low-pressure than in the high-pressure cylinder in forward gear was not inconvenient in express engines, or in fast goods engines, provided that the latter could be reserved for through trains with long runs and little shunting. But for ordinary goods service, when working in back gear, the cut-off took place earlier in the low-pressure cylinder, and was not so suitable for running. If much shunting had to be done with main line goods engines they were found

The unhandiness of the engines, more especially those used for goods traffic, was accentuated by the automatic intercepting valve, which caused them to be less powerful when starting than simple engines. With the intercepting valve closed at the start, there was an increase of back pressure on the high-pressure piston, as the latter compressed the imprisoned air and steam in the receiver. As the pressure in the latter increased, the intercepting valve was blown open and the engine began to

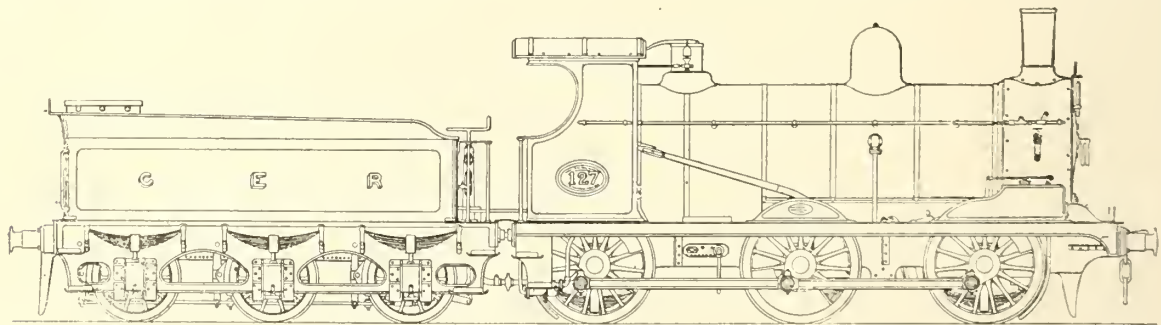

FIG. 321—J. HOLDEN'S TWO-CYLINDER COMPOUND GOODS ENGINE, G.E.R.L.Y., 1887

to be somewhat unhandy. There were methods used on the Continent of overcoming this defect, but they were somewhat complicated, and, as far as the writer is aware, were not used in this country. All T. W. Worsdell's passenger tank

work as a compound after about half a revolution, before it could exert sufficient power to overcome the resistances quickly enough. With non-automatic valves, the engine could have got away much more rapidly by working as a simple engine for

several revolutions. In the later German two-cylinder compound engines, v. Borries and others discarded automatic for non-automatic valves.

Performances of Two-cylinder Compound Engines.—The earlier N.E.R. 4-4-0 compound express engines—Fig. 316 *ante*—were used principally on the main line between Newcastle and Edinburgh. Hardly any independent records of their best work exists, but they were used on the 1888 racing trains on which one of them, No. 117, made the 124½-mile through run at the rate of 57¼ miles per hour. The load was only seven six-wheeled coaches, or about 92 tons, exclusive of passengers, etc.

had that been done, the saving due to compounding alone would have been ascertained. S. W. Johnson, on the Midland Railway, obtained a large reduction in fuel consumption by increasing the pressure from 140 lb. to 160 lb. in otherwise generally similar non-compound express engines. Advocates of compounding argued that a compound engine could utilise the higher pressure better than a simple engine, but at that period pressures had by no means risen to a point beyond which an increase in then existing simple locomotives had been proved in practice to be uneconomical.

Similar remarks apply to the North-Eastern

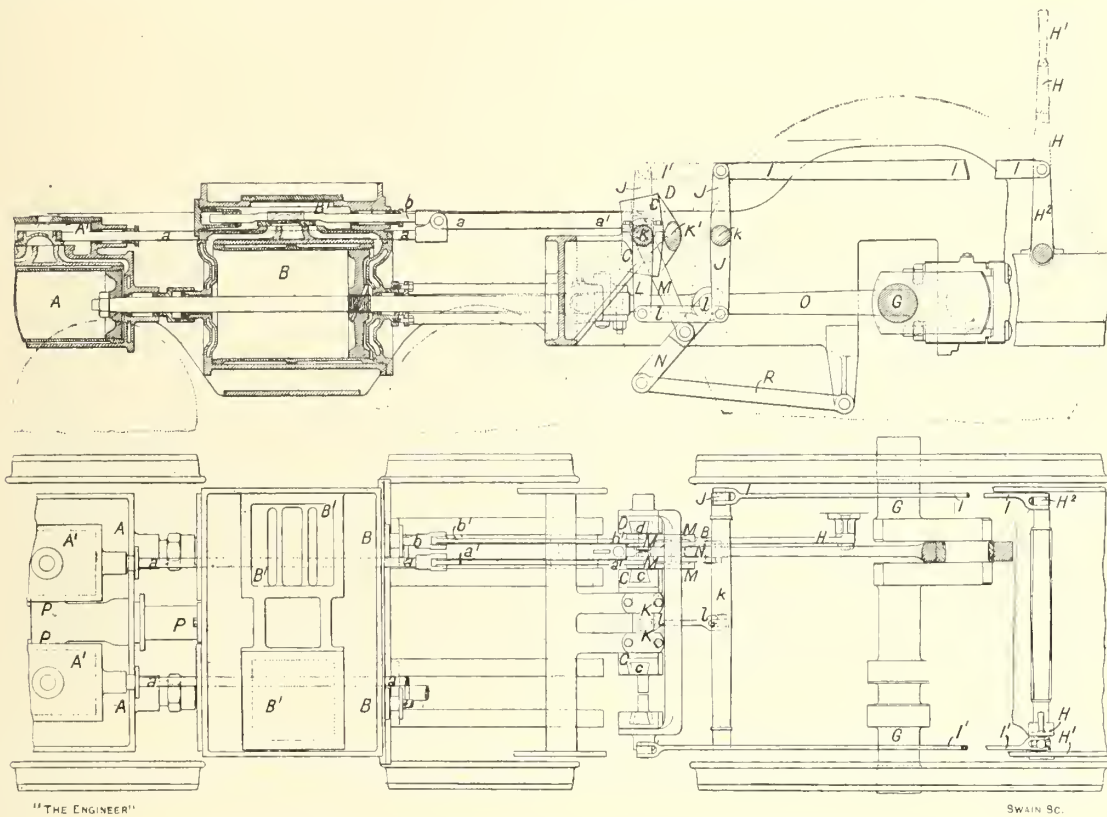

FIG. 322.—NESBIT'S FOUR-CYLINDER TANDEM COMPOUND ENGINE, N.E.R., 1885

Ten similar non-compound engines, with 18in. by 24in. cylinders, were built at the same time, but with the important difference that they carried only 140 lb. pressure, whereas the compounds had 160 lb. Trials covering about 900 miles total train mileage—950 miles engine mileage—with twenty vehicles, weighing 160 tons, showed that the compounds consumed 28.3 lb. and the non-compounds 35.9 lb. of coal per *train* mile. The saving for twelve months' work was stated by T. W. Worsdell to be 14½ per cent. in favour of the compounds.

It is obvious that the two classes were not worked under similar conditions as regards boiler pressure;

goods engines, of which ten non-compounds were built, with 18in. by 24in. cylinders and 140 lb. pressure. On the Newcastle, York and Leeds express goods trains these engines averaged 40.9 lb. per mile, as compared with ten compound engines which consumed 34.9 lb. per mile, the latter having 160 lb. pressure. These figures covered a total mileage for each type of about 186,000.

The large 4-2-2 express engines occasionally attained extremely high speeds. In *The Engineer* of March 7th, 1890, a number of indicator diagrams were given, one set of which, with a gross load of 310 tons 6 cwt., or about 220 tons net behind the tender, shows 1041.4 indicated horse-

power at 75 miles per hour, and another 1068.6 indicated horse-power at 86 miles per hour on the level. They were probably taken just beyond the foot of a descending gradient.

Notwithstanding these performances, about four years later Wilson Worsdell, who had succeeded T. W. Worsdell as chief locomotive engineer of the North-Eastern Railway, converted all ten engines of this class to non-compounds, with 19in. by 24in. cylinders, piston valves, and direct motion driven by Stephenson's gear. It was stated that the outside steam chests—Fig. 318—gave trouble through cracking, owing to their exposed position. From 1900 onwards all two-cylinder compound engines, both passenger and goods, were similarly converted to simple engines.

Four-cylinder Tandem Compound Locomotives.
—In 1885-86 three experimental tandem loco-

passed through a central pipe P to the low-pressure cylinders. The valve rods were connected to sliding blocks in the quadrant links C and D, of which the inner two C C controlling the high-pressure valves were moved by a reversing gear independent of that which actuated the outer quadrants D D for the low-pressure valve rods.

The N.B. engine worked as a compound for some years, though nothing was published in regard to results. It was afterwards reconverted to a simple engine.

On the Great Western Railway in 1886 W. Dean built two tandem compound locomotives with inside cylinders. The first engine, No. 7, was constructed for the standard gauge, and from the exterior there was nothing to show that the engine was a four-cylinder compound—Fig. 323. The low-pressure cylinders in front were 23in. dia-

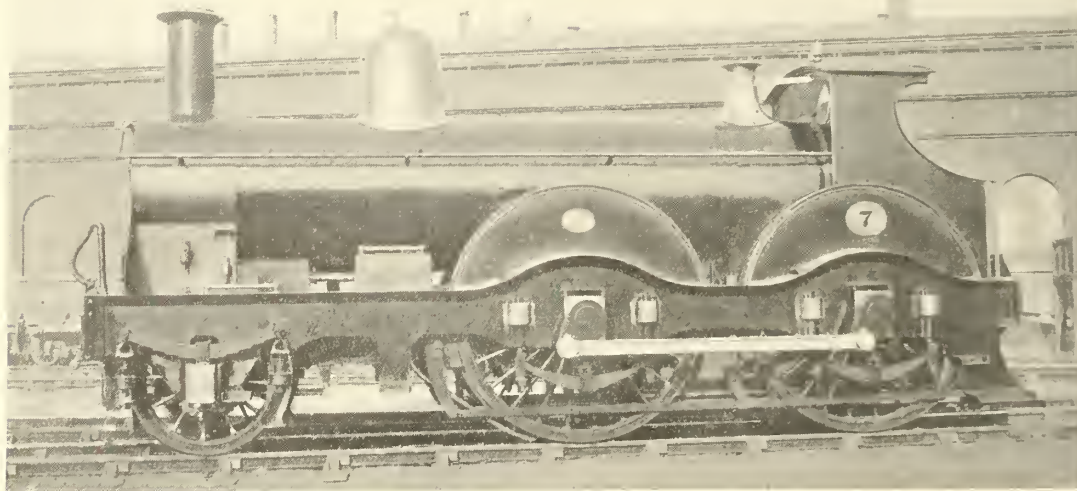

FIG. 323—W. DEAN'S TANDEM COMPOUND STANDARD GAUGE ENGINE, G.W.R.LY., 1886

tives, with four inside cylinders, were made, some account of which will be of interest.

The first engine, on W. H. Nesbit's patent, was placed in service at the end of 1885 on the North British Railway. It was a reconstructed 4-4-0 engine, which had been originally built at Cowairs in 1871, and was of historical interest in that it was the ill-fated engine which had gone down with the Tay Bridge in the 1879 disaster. The coupled wheels were 6ft. 6in. diameter, and before conversion to a compound engine the inside cylinders were 17in. by 24in. They were replaced by a pair of 20in. low-pressure cylinders, in front of which a small pair of 13in. high-pressure cylinders was placed. The stroke was 24in. The old valve gear was removed, and a modification of Joy's gear substituted. The general arrangement was similar to that shown in Fig. 322, which is taken from Nesbit's patent drawing—No. 16,967 of 1884. The exhaust from the high-pressure cylinders A

meter, the high-pressure cylinders behind being 15in. diameter, with a common stroke of 21in. The ratio, 2.35, was practically the same as in Nesbit's engine. The high-pressure and low-pressure cylinders on each side were in one casting, the two low-pressure cylinders being jointed and bolted together in the manner usual at that time, the centres being 2ft. 3in. apart. The high-pressure and low-pressure cylinders were separated by a hollow cover, which fitted into the bore of the high-pressure cylinder, and was attached to the main casting by studs, the nuts of which were placed inside the low-pressure cylinder. This cover was provided with a central bronze bush about 6½in. long, through which the piston-rod between the two cylinders passed. A single piston-rod served both cylinders, the portion in the low-pressure cylinder being 4in. diameter, turned down to 3½in. diameter through the high-pressure piston and cylinder. The low-pressure piston was

formed of a central piece and an outer ring jointed together. Both cylinders and valve faces were horizontal. The low-pressure ports, 11 in. by 1½ in. and 2½ in., were underneath the cylinders, the slide valves being balanced. The exhaust passages were carried upwards round the high-pressure cylinders on the inside and thence forward along the top of the low-pressure steam chests, which were placed above their cylinders. The low-pressure steam ports were 15 in. by 2 in., and the exhaust passed directly upwards through a circular hole 10¾ in. diameter in the back of the balanced slide valve. The two valve spindles were secured at the rear to the top and bottom respectively of a crescent-shaped yoke, to the centre of which the main single valve rod was attached, the latter being actuated by ordinary Stephenson link motion with lifting links. The cut-off, release, and other valve events were similar for both cylinders. The travel in full forward gear was 4⅝ in.; outside lap, 1 in.; no inside lap or clearance. Full port openings 1⅝⅓ in. at both ends. Cut-off in full

which the fire-box with water pockets contributed 137.7 square feet; grate area, 18.33 square feet. The weight in working order was 44 tons, 13 tons being carried on the leading wheels, and 15½ tons on each pair of coupled wheels. The weight empty was 40 tons 18 cwt.

The other engine, No. 8—Fig. 324—was built as a broad—7 ft.—gauge convertible engine with six frame plates. The driving and trailing axles had four bearings each, and the leading axle also had four bearings, the outer one being placed as shown in the outside frame. Had the engine been converted to standard gauge these outer frames would have been discarded, and the engine would have resembled the previous engine. The wheels, wheel base, and boiler were similar to those of engine No. 7, but the cylinder dimensions and arrangement were completely different. The high-pressure cylinders were 14 in. diameter and the low-pressure 22 in. diameter by 21 in. stroke. Cylinder ratio, 2.47. The cylinders, the centres of which were 2 ft. 3 in. apart, were inclined down-

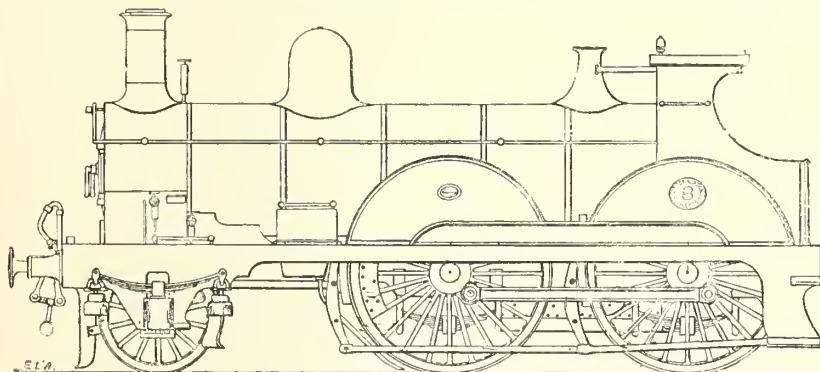

FIG. 324—W. DEAN'S TANDEM COMPOUND BROAD GAUGE ENGINE, G.W.R., 1886

gear 69.7 per cent. on front stroke, and 53.2 per cent. on back stroke, the difference being partly due to the setting of the valves to equal port openings, the leads being ⅝⅓ in. front and ⅝⅓ in. back. In the first notch from midgear the valve travel was 2⅝ in., the points of cut-off for front and back strokes being 27.1 and 19 per cent. respectively. The valve events left a great deal to be desired for a compound engine, and there was too much compression. Boiler steam at reduced pressure could be admitted to the low-pressure cylinders at the will of the driver. A safety relief valve was placed on the front of the steam chest cover.

The engine had double frames throughout. The driving wheels were 7 ft. diameter, and the leading wheels 4 ft. To carry four cylinders at the front the leading wheels were placed well forward, 10 ft. 2 in. from the driving wheels, the coupled wheel centres being spaced 8 ft. 4 in. apart. Total base 18 ft. 6 in. The leading axle-boxes had side play in the horns, as in the Midland 2-4-0 engines. The boiler, which carried 180 lb. pressure, had a total heating surface of 1258 square feet, towards

wards at 1 in 12 towards the crank axle, and both high and low-pressure cylinders had steam chests underneath, the port faces being inclined upwards, so that the Stephenson link motion provided a direct drive. The special feature was the arrangement of piston-rods, which was somewhat similar to that subsequently used in 1888-89 by Monsieur Du Bousquet for a number of eight-wheels coupled tandem-compound goods engines on the Ch. de fer du Nord. The low-pressure cylinders were placed in front, and their pistons, in this case solid, each had two rods, which issued from stuffing-boxes outside and at the sides of the small high-pressure cylinders. The end partition between the high-pressure and low-pressure cylinders was in one piece with the main casting, since no bush was required; in fact, all four cylinders were cast in one piece. The high-pressure piston-rod was central. There were two slide bars, and the crosshead had projecting wings on each side, to which the two outer low-pressure piston-rods were secured by nuts, the central high-pressure rod being connected to the crosshead in the usual manner. Each other rod was 9 in. from the central

rod, centre to centre. The valves and valve spindles were at 1ft. 4in. centres.

Both engines were purely experimental, the designs having been made in 1885. Mr. Dean told the writer, who travelled on the engines during their trials, that he considered it his duty to try compound engines, and seeing that Webb's and Worsdell's systems were being fully tried elsewhere, he thought that his own experiments should be made with the tandem system, though many difficulties would have to be got over.

The engine No. 7 gave a great deal of trouble owing to the piston-rod bushes between the low-pressure and high-pressure cylinders, the lubrication of which was difficult, with the result that the low-pressure piston-rods were badly scored. It would have been better had the cylinders been separated as in the North British engine, but this would have necessitated lengthening the engine and providing a bogie, and would also have added to the weight of the reciprocating parts. The engine ran for some time, chiefly on slow trains between Swindon and Cardiff, but the danger of further trouble with the bushes precluded its use on express trains.

The broad gauge engine, No. 8, had several bad smashes during the trials, in which the low-

pressure pistons were broken to bits, and both cylinder covers knocked off. It was thought that the three piston-rod arrangement caused the large piston to corner slightly in the cylinders owing to unequal expansion of the rods. But there was also the danger of water of condensation in the low-pressure cylinder, when working with an early cut-off, and, moreover, it is easy to produce excessive cushioning in a compound locomotive, more especially in the high-pressure cylinder, since the initial pressure is small relatively to the terminal pressure. The clearance space volumes in both high-pressure and low-pressure cylinders was certainly too small, just as they were in the early French four-cylinder compounds. Nevertheless, the pistons of engine No. 7, with one central rod only, never broke, whilst those of No. 8 with three rods were completely smashed on three occasions, on the first of which three pistons and four cylinders were broken. There was a relief safety valve on each of the low-pressure steam chest covers, but none on the high-pressure cylinders.

The tandem system for express work has the great disadvantage of heavy reciprocating masses. The three engines described were the only tandem compound locomotives ever used in this country.

Chapter XIX—1882-89, Non-Compound Locomotives

THE engines described in this section are simple locomotives contemporary with the compounds dealt with in the preceding chapter. There was a marked revival of the "single" engine, more especially after the invention of the steam sanding apparatus in 1886.

2-2-2 Engines.—The last 2-2-2 engines with outside cylinders built in this country were constructed at the Gorton Works of the Manchester, Sheffield and Lincolnshire Railway in 1882-83 to Charles Sacré's designs—Fig. 325. The arrangement was a more modern adaptation of Allan's old "Crewe" type. The leading dimensions of these and the following engines are given in Table IX, and it is sufficient to add here that the cylinders were 17½ in. by 26 in., and the driving wheels 7 ft. 6 in. diameter. Amongst the main features were the comparatively short wheel base, which resulted in a somewhat jerky swaying

min., was sometimes performed in 16 min. The engines were very powerful, and the way in which they started and got away with their trains like coupled engines was very marked. The weight on the driving wheels was officially recorded in 1883 as 17 tons 11 cwt., but C. Rous-Marten once informed the writer that he knew definitely that the actual weight on the drivers was considerably greater. In this connection it may be added that some of the "single" engines of the 1880-1900 period had more adhesive weight than was admitted in the published figures. The weights given in the Table are the latter.

Of P. Stirling's 2-2-2 engines with 7 ft. 7½ in. driving wheels and 18½ in. by 26 in. cylinders shown in the Table, twenty-one were built between 1886 and 1894—Fig. 326, as well as two similar but smaller ones in 1885. They were excellent straightforward engines, the chief

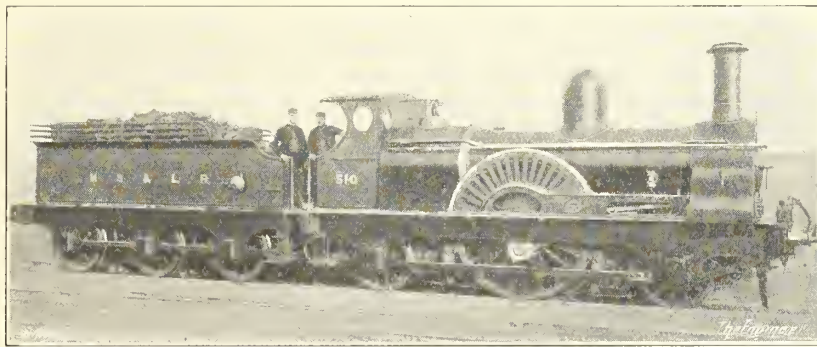

FIG. 325—C. SACRÉ'S SINGLE DRIVER LOCOMOTIVE, M.S. & L. RLY., 1882-83

[Photo. Locomotive

movement at high speeds, the raised fire-box casing, to which Sacré was always very partial, and the marine type connecting-rod big ends. The latter was also extensively used on the inside cylinder engines of this railway. Subsequently, Mr. J. G. Robinson altered them to the usual type with straps and bolts, and the smoke-boxes were also lengthened. The journals of the carrying wheels were double coned, and the fire-box was direct-stayed. Between 1883 and 1887 three of these engines worked the special London expresses between Manchester and Grantham. Though the gradients between Manchester and Retford are very severe, the trains were light. The remaining engines, and after 1887 the whole twelve, worked the fast 40 and 45-minute expresses on the Cheshire lines between Manchester and Liverpool. These trains were somewhat heavier, and the 15¾-mile run from Manchester (Central) to Warrington, which was booked to be done in 18

characteristics of which were the very long wheel base and the smallness of the boiler, which, in justice to the engines, hardly seemed to trouble them at all, even with heavy loads at very high speeds. There used to be certain classes of engine, and these were of the number, the performances of which upset preconceived calculations on the subject of heating surface and boiler power. It is true that the great majority of them were large-wheeled single engines, in which a larger proportion of indicated horse-power was converted into draw-bar horse-power. The wheel base of 19 ft. 1 in. would usually be described as "rigid," but the leading axle-boxes had lateral play in the guides equal to 7/16 in. on each side, or 7/8 in. total, as in the Midland 2-4-0 engines. Both carrying axles had journals 10½ in. long of concave form.

These engines worked in the same links as the 4-2-2 singles with 8 ft. driving wheels, and for

ten years P. Stirling built both types concurrently to work the same trains. As regards maximum recorded speeds, the 7ft. 7½in. singles with inside cylinders had somewhat the better of it.

The Great Western engine, No. 9—see Table—

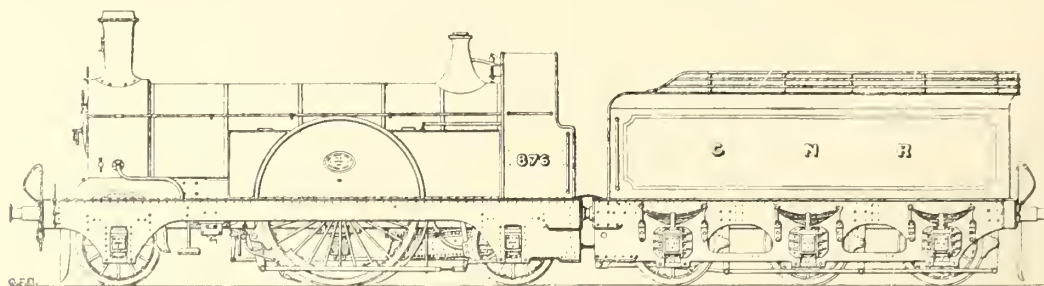

FIG. 326—P. STIRLING'S SINGLE EXPRESS ENGINE, GREAT NORTHERN RLY., 1885

was built at Swindon in 1884 to W. Dean's design, and had 7ft. 8in. driving wheels and 18in. by 26in. inside cylinders—Fig. 327. The valves were placed on top and were actuated by rocking shafts and Stephenson's link motion placed outside. The reason for this peculiarity was that the wheels and motion were taken from the experimental 4-2-4 tank engine of 1881, described on page 219. The writer's experience of No. 9 was that it could pull very heavy trains, but that as regards speed it was inferior to the standard G.W.R. 2-2-2 engines with 7ft. wheels. It was the only engine of its class, and in 1890 was reconstructed as a 7ft. single engine with outside bearings throughout and the driving wheels reduced to 7ft.

Another Great Western engine—No. 10—with 7ft. 8in. wheels and 18in. by 26in. cylinders was

with No. 9 on the heaviest South Wales expresses between Swindon and London. Though it was a somewhat faster running engine, it was also converted in 1890 to a 7ft. single.

The Great Eastern engines—see Table—of which twenty-one were built at Stratford between 1888 and 1893, were of James Holden's design—Fig. 328. The driving wheels were 7ft. diameter, and the cylinders 18in. by 24in. The last ten engines carried 160 lb. pressure, the earlier examples having 140 lb. In all except the first engine, the dome was placed on the front ring of the barrel. The type was peculiar in that outside bearings were used for the leading axle only, those of the trailing axle being inside. This arose from the fact that the engines were similar to the standard 2-4-0 engines, except that the

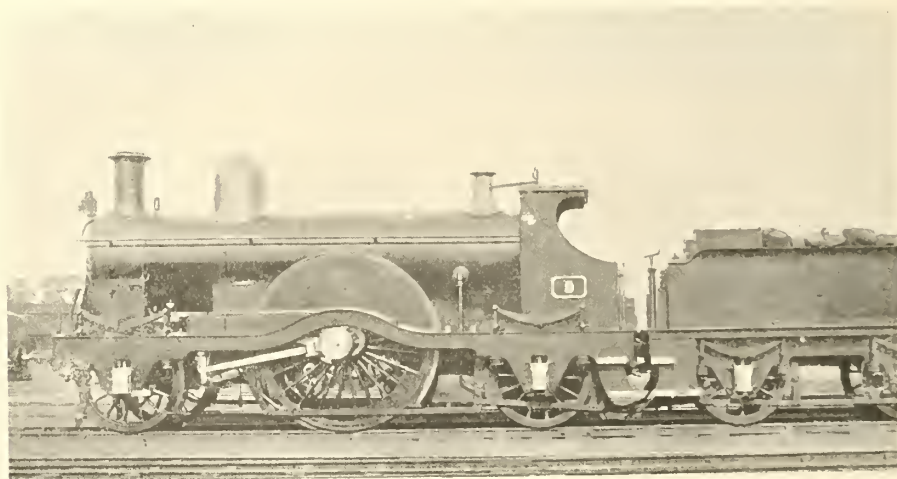

FIG. 327—W. DEAN'S SINGLE DRIVER EXPRESS ENGINE, G.W.R., 1884

built by W. Dean at Swindon in 1886. It had double frames and outside bearings throughout. The cylinders were cast together, with the steam chests below, the valves being driven directly by Stephenson's gear. The driving springs were

trailing coupled wheels were replaced by small carrying wheels. The steam chests were below the cylinders and the valves, of Trick pattern, were driven by direct Stephenson motion. C. Rous-Marten had a number of curious experiences with

these and the similar 2-4-0 engines, in that he generally found that the single engines with similar loads climbed the banks faster than the coupled engines, but that the latter attained greater speeds downhill.

the exhaust was divided, that from the top of the valves passing directly to the blast-pipe, the portion from the bottom being taken round the cylinders, in accordance with D. Drummond's views. This arrangement enabled the cylinders



FIG. 328—J. HOLDEN'S SINGLE DRIVER EXPRESS ENGINE, GREAT EASTERN RLY., 1888-93 [Photo. Locomotive

4-2-2 Engines.—The first actually new single engines with inside cylinders and frames and leading bogie were built in 1885 by Beyer, Peacock and Co. for the Great Northern Railway (Ireland), though they had been preceded by the converted Bristol and Exeter engines—Fig. 271 *ante*.

In 1886 Neilson and Co. built for the Edinburgh Exhibition the 4-2-2 engine—see Table—with 7ft. driving wheels and inside cylinders 18in. by 26in.—Fig. 329. The engine was designed by the builders, though, as it was purchased by the

to be placed at 2ft. 3in. centres, and allowed somewhat more space for wider crank webs and longer driving bearings, but had the disadvantage of taking part of the damp exhaust steam for a long distance in contact with the cylinder walls. The blast-pipe was of the Adams's "vortex" pattern. The motion plate was of cast steel, and the driving springs were helical. The fire-box crown was elliptical, supported by sling stays attached to bridge rails riveted to the casing. The engine was fitted with air-sanding apparatus, invented just before on the Midland Railway.



FIG. 329—NEILSON'S SINGLE DRIVER ENGINE, CALEDONIAN RLY., 1886 [Photo. Locomotive

Caledonian Railway, D. Drummond's cab, boiler fittings and certain other details were embodied. Like those of nearly all the engines described above, the boiler was of iron. The slide valves were placed vertically between the cylinders, but

During the 1888 race of the London-Edinburgh day Scotch expresses, this engine, No. 123 of the Caledonian Railway, ran with a load of four bogie coaches between Carlisle and Edinburgh, $100\frac{3}{4}$ miles, maintaining a daily average time of $107\frac{3}{4}$

min. The run included the long climb up the Beattock bank, of which 2 miles are at 1 in 88, 2 miles 1 in 80, and 6 miles at 1 in 75. The best time was 102 min. 33 sec., at an average speed of 58.94 miles per hour. Full details of this performance were published in *The Engineer* of March 13th, 1891.

The first of S. W. Johnson's celebrated 4-2-2 engines—Fig. 330—on the Midland Railway,

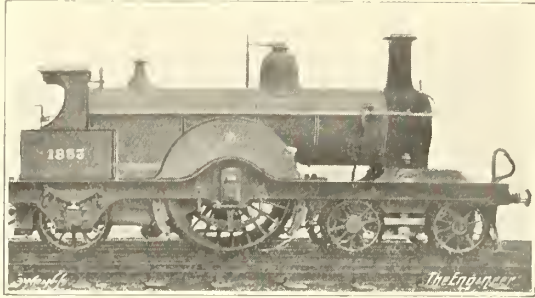

FIG. 330—S. W. JOHNSON'S SINGLE EXPRESS ENGINE, MIDLAND RLY., 1889-93

came out in 1887 and were fitted with the steam sand blast, without which it is safe to say there would have been no single engines on this railway, with its extremely severe gradients. Of the sixty engines of this class, eighteen, built 1887-90, had 7ft. 4in. driving wheels, and 18in. by 26in. cylinders, and the other forty-two, 1889-93, had 7ft. 6in. wheels and 18½in. by 26in. cylinders. The engine illustrated is that exhibited at Paris in 1889, and was the first with the larger wheels and cylinders. All these engines had inside and outside bearings for the driving and outside only for the trailing axles, in order to obtain sufficient bearing area. The cylinders were horizontal, with steam chests between and direct exhaust. Stephenson's link motion was employed. All the boilers were of steel and carried 160 lb. pressure.

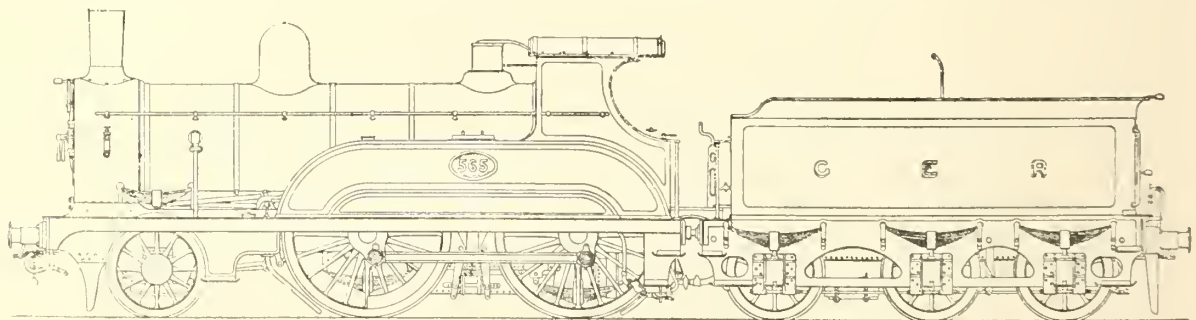

FIG. 331—T. W. WORSDELL'S 2-4-0 EXPRESS ENGINE, G.E. RLY., 1882

2-4-0 Express Engines.—Amongst the leading railways which adhered to the 2-4-0 type were the Great Western, London and North-Western and Great Eastern. On the London and North-Western, the "Precedent" class entered upon a new lease of life in 1887-94, when ninety-six new

engines were built. They differed from the 1874-82 series principally in that the pressure was raised to 150 lb. and the driving wheels were increased from 6ft. 7½in. to 6ft. 9in. diameter by using thicker tires. The original series was correspondingly altered, so that there were 166 of the class. The boiler dimensions remained as before. The best work of these engines was done after these modifications had been made.

In 1882-83 T. W. Worsdell built twenty handsome 2-4-0 express engines at the Stratford works of the Great Eastern Railway, with 18in. by 24in. cylinders, 7ft. coupled wheels, and 140 lb. pressure. The leading wheels, 4ft. diameter, had Webb's radial axle-boxes, a somewhat unsteady arrangement for a six-wheeled engine, leaving the guiding to be done by the short wheel base of the coupled axles. The wheel base was 8ft. 9in. + 8ft. 9in. Joy's valve gear was fitted. The total heating surface was 1200 square feet, of which the fire-box provided 117.5 square feet; grate area, 17.3 square feet; total weight in working order, 41 tons 3 cwt., of which 28 tons 3 cwt. 3 qr. were available for adhesion. These engines, which had the long combined splashers introduced by Mr. Worsdell, and are illustrated by Fig. 331, were similar to the compound engines—Fig. 315 *ante*—with the exception that in the latter a bogie replaced the leading single axle.

The Great Western engines of 1881-86 had inside bearings for the coupled and outside bearings for the leading wheels, as in the Midland 2-4-0 engines, and are illustrated by Fig. 332. The cylinders were 17in. by 24in., diameter of coupled wheels 6ft. 6in., pressure 140 lb. Ten engines of 1882 had domeless boilers, with a total heating surface of 1268½ square feet, but in 1886 domes reappeared. In 1889 a completely new type was built, as described later.

The North-Eastern Railway in 1884, under A. McDonnell, had adopted the 4-4-0 type, with

6ft. 7in. coupled wheels and 17in. by 24in. cylinders, but in 1885 a return was made to the 2-4-0 type, as shown in Fig. 333. These excellent engines, known as the "Tennants," were designed during the interval between the resignation of McDonnell and the appointment of T. W.

Worsdell as chief locomotive superintendent, and therefore preceded the compound engines. They may be described as a modernised Fletcher type, and the motion and many of the details were similar to those of Fletcher's engines. In outward appearance they bore some resemblance to P.

tained in the steam chests at higher speeds. The leading axle had both inside and outside bearings, the inside journals being without collars, and a total lateral play of 1 in. was provided. In appearance, the engines were very similar to the 2-2-2 engines. They are illustrated by Fig. 334.

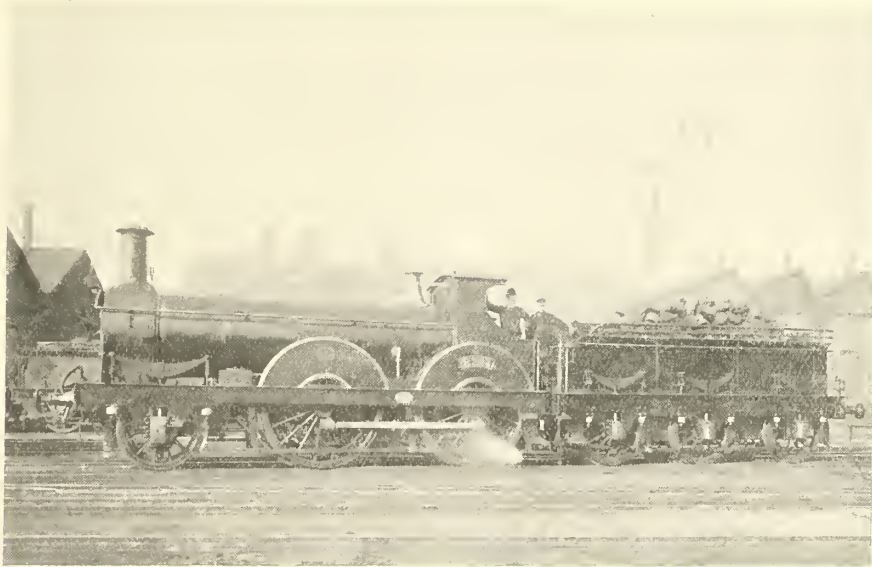

[Photo. Locomotive

FIG. 332—W. DEAN'S PASSENGER ENGINE, GREAT WESTERN RLY., 1882

Stirling's G.N.R. coupled engines, but the boilers, which were of considerably larger size, had domes. Dimensions are given in Table X.

James Holden's Great Eastern engines of 1886-97, of which 110 were built at Stratford, had, like the North-Eastern engines, 7 ft. coupled wheels and 18 in. by 24 in. cylinders, cast together at 2 ft. centres, but the steam chests were below

The engines—Fig. 335—three of which were built in 1887 by the Manchester, Sheffield and Lincolnshire Railway to the designs of T. Parker, were unique in that they combined double frames with outside bearings for the coupled wheels, and inside bearings only with Webb's radial axle-boxes for the leading wheels. They replaced the Sacré 7 ft. 6 in. singles on the Manchester-Gran-

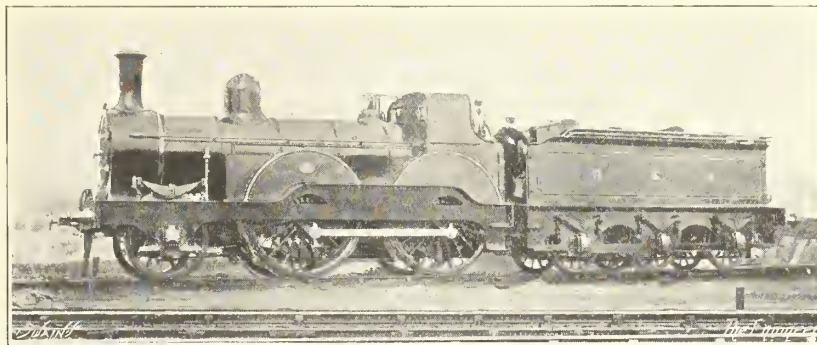

[Photo. Locomotive

FIG. 333—H. TENNANT'S EXPRESS LOCOMOTIVE, N.E. RLY., 1885

the cylinders, inclined upwards towards the driving axle, and Trick slide valves were used. The later engines had two rings instead of three in the boiler barrel, and 160 lb. instead of 140 lb. pressure. The steam pipe was 5½ in. diameter, with the result that a better pressure was main-

than expresses, but the radial axle-boxes caused them to be somewhat unsteady, and in the succeeding three otherwise similar engines of 1888, four-wheeled bogies were substituted. There were two motion plates, of which one near the cylinders carried the front end of the slide bars and the

valve spindle guides, and the other in the usual position carried the back ends of the slide bars. The bars did not rest upon lugs on the cylinder covers, and were therefore not subjected to heat conducted from the latter. These engines had

care being taken to provide a partition which separated the exhaust passages from the cylinder walls. The slide valves, of the Trick type, were balanced and inclined upwards towards the driving axle, giving a direct drive from the



FIG. 334—J. HOLDEN'S OIL-FUEL EXPRESS ENGINE. GREAT EASTERN RLY., 1886-97

[Photo. Locomotive

Ten of these engines were fitted to burn oil fuel.

18in. by 26in. cylinders, 6ft. 9in. coupled wheels, and 160 lb. pressure.

The Great Western 2-4-0 engines, built at Swindon in 1889 to W. Dean's design—Fig. 336—are remarkable in that a return was made to double frames, the outside framing being of the sandwich pattern. This differed from the former designs with solid oak planking between the fitch plates, in that the long teak blocks were used in conjunction with short cast iron strengthening blocks spaced at intervals opposite the cross stays

Stephenson link motion. The coupled wheels were 6ft. 1½in. diameter and the working pressure 160 lb.

Two large 2-4-0 broad-gauge convertible engines—see Table—were also built at Swindon in 1888, with double frames placed inside the wheels—Fig. 337. The sandwich framing was of similar design to that of the preceding engines. The extremely large cylinders, 20in. by 24in., were also arranged with the steam chests below similarly to those described above. The coupled wheels

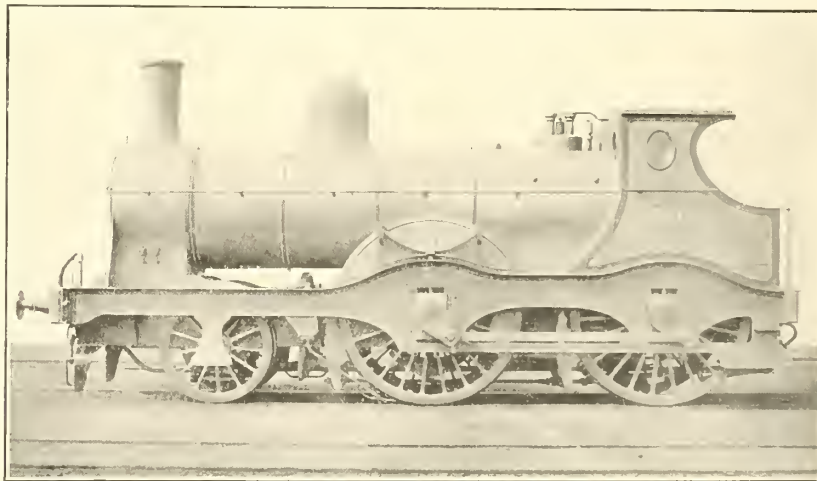

FIG. 335—T. PARKER'S EXPRESS LOCOMOTIVE. M.S. & L. RLY., 1887

and also at the points where the spring hangers passed through. The hornblocks were of cast iron, each being independent and not of the usual horseshoe pattern. The 18in. by 24in. cylinders were cast in one piece with the steam chests below,

were 7ft. 0½in. diameter. These engines were built to work a very heavy broad-gauge express train between Bristol and Swindon, which had always required a pilot engine owing to the Box Tunnel and Wootton Bassett gradients of 1 in 100. After

the broad-gauge had disappeared in 1892, the engines were completely reconstructed, and were not converted to standard gauge in their original form.

The dimensions of these and other coupled engines are given in Table X.

illustrated in *The Engineer*, February 6th, 1885. The boilers had only 1121.6 square feet total heating surface, about 100 square feet less than those of Johnson's earlier engines of 1875-78, with 17in. by 24in. and 18in. by 26in. cylinders. The reduction was due to the fewer tubes. It was

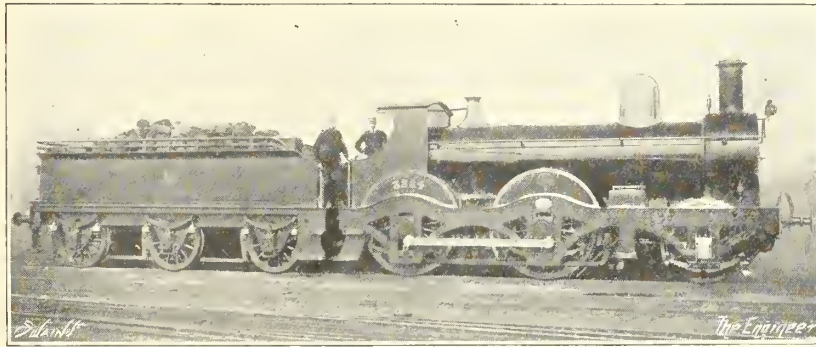

FIG. 336—W. DEAN'S PASSENGER ENGINE, G.W.R., 1889 [Photo. Locomotive]

4-4-0 Engines.—Some engines were designed by A. McDonnell for the North-Eastern Railway, and twenty-eight were built at Gateshead Works and by R. and W. Hawthorn in 1884-85, preceding both the 2-4-0 "Tennants" and Worsdell's compounds—see Table X. The design followed the lines of the same engineer's locomotives on the Great Southern and Western Railway of Ireland, and were the first in Great Britain to have pendulum link bogies. The valve rods were suspended by swing links. The cylinders were 17in. by 24in., the coupled wheels 6ft. 7in. diameter, and the pressure 140 lb. Although originally intended for the East Coast main line expresses, they were too small for this work, and were shortly afterwards superseded by the 2-4-0 "Tennants." The dimensions given are those of

stated that the drivers were expected to notch the engines up as far as possible when running, but although the engines were excellent runners with light trains they easily "ran out of breath" with heavy ones. There was, however, another reason for the reduced heating surface, which, as far as the writer is aware, has not hitherto been mentioned in connection with these engines. At about this period, and for some years afterwards, considerable trouble was experienced on several railways with cracked fire-box copper tube-plates, and a reduction in the number of tubes was found to be advantageous. One of the causes was the extreme purity of the copper supplied by the manufacturers, who were trying to meet the requirements of electrical engineers in regard to conductivity. The pure copper was by no means

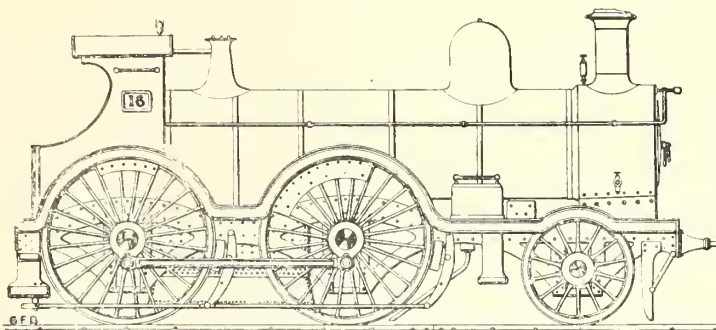

FIG. 337—BROAD-GAUGE CONVERTIBLE EXPRESS ENGINE, G.W.R., 1888

the first engines; the later engines had a longer wheel base and weighed 39½ tons in working order.

The ten Midland engines, "1667" class, by S. W. Johnson, built at Derby in 1884, had large 19in. by 26in. cylinders, with the valves above, and Joy's valve gear. In outward appearance they were very similar to Fig. 277 *ante*, and were also

so suitable for fire-boxes as that generally supplied in former years. It was subsequently found that the beneficent impurity in the copper of old fire-boxes was arsenic, and, as a result, it is now specified as obligatory.

The "1667" class, under consideration, were not the first Midland express engines to have the

tubes reduced from 223 to 205, for the previous "1562" class, with 6ft. 9in. wheels and 18in. by 26in. cylinders, had similar boilers. It may be asked why Mr. Johnson did not increase the diameter of his boilers and retain the original number of tubes. That course would have involved increasing the weight of the engines, which it was then desirable to avoid. But in the next series of 4-4-0 engines, the "1740" class, of 1885-87, dimensions of which are also given in the table, the boilers were made of steel in place of Low Moor iron used in the "1667" class, and the number of tubes was increased to 246, their diameter being decreased from 1 $\frac{3}{8}$ in. to 1 $\frac{1}{2}$ in. outside. The cylinders were 18in. by 26in., the standard size from 1877 to 1883, and to obtain increased power the pressure was raised to 160 lb. Joy's valve gear was discarded, and the previous Stephenson's link motion fitted. The "1740" class were amongst the most successful engines of their day. Further, in 1886-87, the ten engines

successful. Apparently they were, and by 1899 there were 117 engines of the class with 19in. cylinders. But the boiler, though of larger diameter, had even less tube and fire-box heating surface than the Midland "1667" class, to the extent of about 100 square feet. Nevertheless J. Stirling's engines did very good work, and larger boilers were not required until 1898, when the diameter was increased to 4ft. 8 $\frac{1}{2}$ in., the total heating surface to 1100 square feet, and the pressure, which in 1889 had become 150 lb., was then raised to 160 lb. The Midland engines had to run at considerably higher average speeds, and the trains with which they were not successful were the Scotch expresses between London and Leicester, the heaviest on the line. But Stirling's engines with boilers of larger diameter had the advantage of greater heat storage capacity, in spite of their inferior heating surface.

There were several features of interest in the design. The bogie was of a special type with

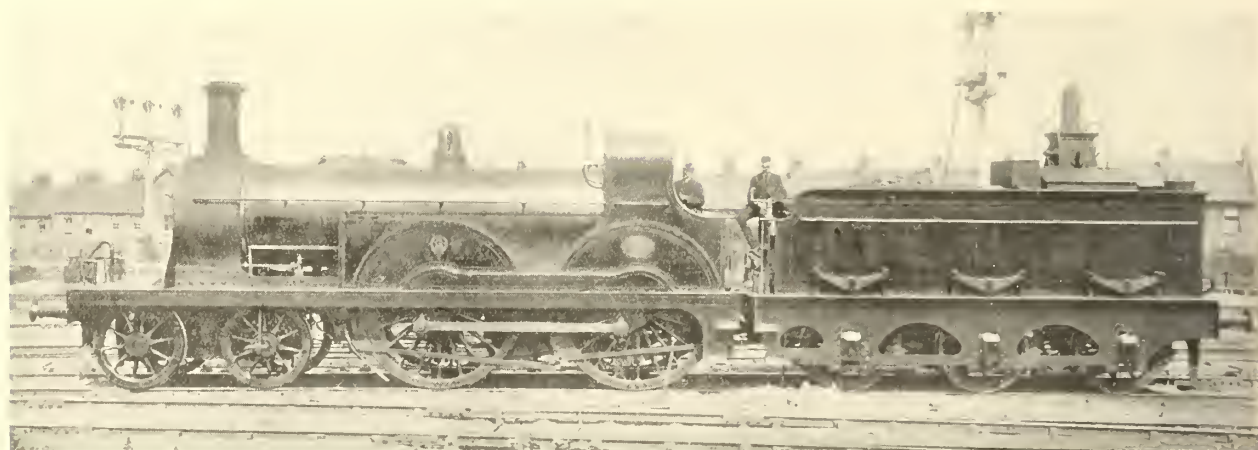

FIG. 338—J. STIRLING'S EXPRESS LOCOMOTIVE, SOUTH-EASTERN RLY., 1885-98

[Photo. Locomotive

of the "1667" class, still retaining the 19in. cylinders and Joy's gear, were provided with the "1740" class 160 lb. boilers, the total heating surface of which was 1261 square feet, after which they were much better engines.

The "1740" class, with 18in. by 26in. cylinders and 160 lb. pressure, showed a fuel economy of 11 to 13 per cent. over similar engines with 140 lb. pressure, and for this reason Johnson then considered that there was no necessity for the complication of compounding.

James Stirling's 4-4-0 engines for the South-Eastern Railway—Fig. 338—like their Midland contemporaries of 1884, also had 19in. by 26in. cylinders, but the steam chests were placed between them, with vertical slide valves actuated by Stephenson's link motion. The cylinder centres were 2ft. 4 $\frac{1}{2}$ in. apart. The first four engines had 18in. cylinders, and Mr. Stirling informed the writer that the later cylinders of the first lot were bored out to 19in. to see whether they would be

two pins and a triangular link, and a wheel base only 5ft. 4in. in length—Fig. 339. The front pin received the push from the bogie frame, and the main centre pin, which had about $\frac{3}{8}$ in. lateral movement on each side, was connected by a link to the front pin. The steam reversing gear was of J. Stirling's well-known design, but the steam and cataract cylinders, instead of being placed inside the cab and thence actuating a long reversing rod, were placed vertically in front of the driving splasher, and the piston-rod was directly connected by a short link to the reversing shaft. The boiler, of Siemens-Martin steel in the later engines, was of the domeless type. Drawings of these engines appeared in *The Engineer*, November 29th and December 13th, 1889.

D. Drummond's Caledonian 4-4-0 engines of 1884-89 were similar in general appearance to his North British engines—Fig. 276 *ante*—and had the same characteristics. The dimensions are given in Table X, but it is unnecessary to illustrate the

engines, which were built by Neilson and also at St. Rollox. A modified engine, of similar general design, by Drummond, was built in 1886 by Dübs, and shown at the Edinburgh Exhibition of that year. It had 19 in. by 26 in. cylinders, and the Bryce-Douglas radial valve gear, in which the movement of the valve was derived from the connecting-rod, as in Joy's gear. But it was much more complicated, and included many links and pin joints, to which the engine took such a strong

objection when running that it freed itself by dropping most of the motion on the road on a few occasions. The gear was consequently converted to the standard type. In 1889 four of the standard engines were built with boilers suitable for 200 lb. pressure. Of these, two carried this pressure, one 175 lb. and one 150 lb., for the purpose of comparative trials. The saving in weight of steam of the 200 lb. over the 150 lb. engine was 31 per cent., though the weight and speed of trains were in favour of the

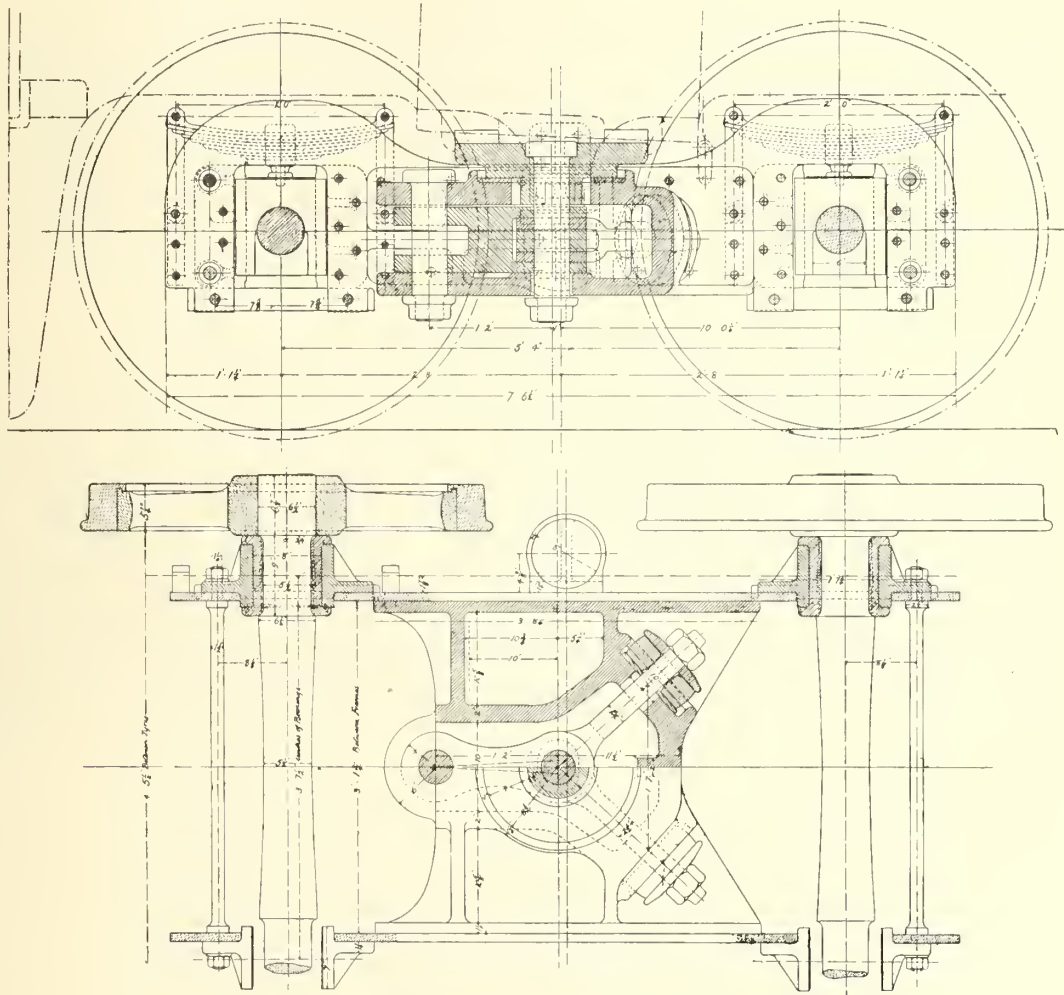

FIG. 369.—J. STIRLING'S LOCOMOTIVE BOGIE, S.E.R., 1885

of the higher pressure, the percentage figures were liable to be somewhat exaggerated in comparison with engines having a straight exhaust clear of the cylinder walls. Drummond came to the conclusion that until drivers worked their engines to take advantage of the higher pressures he could not recommend pressures greater than 170 lb.

Drummond seems to have held the view that the above design of exhaust passages was of advantage in providing "an exhaust steam jacketed cylinder," as he expressed it in his paper,

objection when running that it freed itself by dropping most of the motion on the road on a few occasions. The gear was consequently converted to the standard type. In 1889 four of the standard engines were built with boilers suitable for 200 lb. pressure. Of these, two carried this pressure, one 175 lb. and one 150 lb., for the purpose of comparative trials. The saving in weight of steam of the 200 lb. over the 150 lb. engine was 31 per cent., though the weight and speed of trains were in favour of the

of the higher pressure, the percentage figures were liable to be somewhat exaggerated in comparison with engines having a straight exhaust clear of the cylinder walls. Drummond came to the conclusion that until drivers worked their engines to take advantage of the higher pressures he could not recommend pressures greater than 170 lb.

"Proc." Inst. C.E., 1897. He probably meant that the exhaust steam passage afforded better protection than was the case in some designs not properly shielded from the cold atmosphere. He copied the design from Stroudley, but the latter

with short wheel base was discarded for an Adams sliding bogie, in which the lateral movement was controlled by a special arrangement, such that to whichever side the movement took place the springs on both sides were compressed, instead of



FIG. 340—M. HOLMES'S 7ft. COUPLED EXPRESS ENGINE, NORTH BRITISH RLY., 1886

[Photo, Locomotive

made no claim on behalf of "steam jacketing," and stated that he adopted it to get the cylinders closer together and obtain as strong a crank as possible—see "Proc." Inst. C.E., 1885.

The North British Railway engines by M. Holmes were direct derivatives of Drummond's engines, with cylinders of similar design. Those built at Cowairs in 1886-87 (592 class) had 7ft. coupled wheels, and are illustrated by Fig. 340, but in those of 1890-95 (633 class) the diameter was reduced to 6ft. 6in. Dimensions of both classes are given in Table X.

The Glasgow and South-Western engines—Fig. 341—built at Kilmarnock, 1886-89, to H. Smellie's design, are characterised by the domeless boiler inherited from the Stirlings, but the safety

the springs on either side being alternately compressed and released. The centre rods of the springs were extended to the outside of the frames to allow the wear to be easily taken up in the running sheds. There were twenty of these engines, of which that illustrated was one of four with extended smoke-boxes, the extension taking the form of a drum of smaller diameter. This was, as far as the writer knows, the first application of an extended smoke-box to any engine working in this country, though many had been provided by private builders for overseas locomotives.

The Great North of Scotland Railway engines of James Manson were built by Kitson and Co., 1888, and R. Stephenson and Co., 1890. The

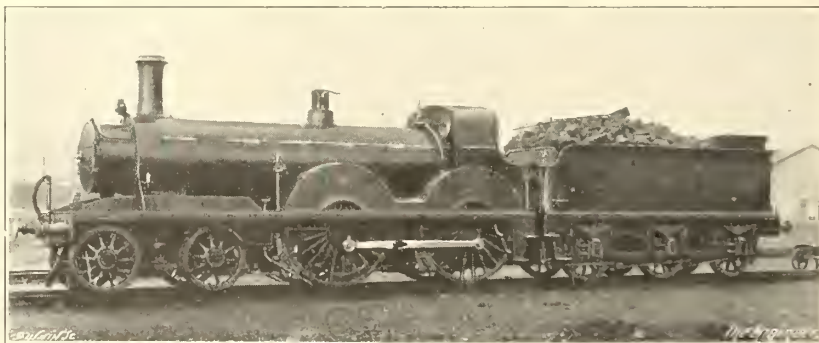

FIG. 341—H. SMELLIE'S PASSENGER LOCOMOTIVE, G. & S.W.R., 1888-89

[Photo, Locomotive

valves were placed on the barrel instead of on the fire-box casing. The fire-box was direct-stayed with one row of sling stays in front. James Stirling's steam reversing gear, placed within the cab, was retained, but his rigid centre pin bogie

latter, which are illustrated by Fig. 342, had eight-wheeled tenders, the front two pairs of wheels only forming a bogie. The other two axles were rigid. Two tenders of similar design were subsequently constructed by Mr.

Manson at Kilmarnock for the Glasgow and South-Western Railway.

The G.N. of S.R. engines had driving wheels 6ft. 0½in. diameter, except three which had 6ft. 6½in. wheels. The cylinders of all were 18in. by 26in., cast in one piece, with their centres 2ft. 2in. apart. The slide valves were on the top, partly balanced by circular relieving rings held up by springs, and driven through rocking shafts by Stephenson's link motion. The lower end of the rocking shaft was immediately in front of the spindle guides, and slotted to receive a rectangular die block, to which the spindle was pinned. The vertical movement of the block in the slot was equal to the versed sine of the arc through which the lower end of the rocking shaft moved. Another feature of interest was the use of a modified form of D. K. Clark's induced air jets in the front and back of the fire-box. These

Lancashire and Yorkshire Railway, built in 1888-89 by Beyer, Peacock and Co., like W. Barton Wright's previous engines for that line, had 6ft. coupled wheels, but in place of the Adams sliding bogie, with 3ft. 7¼in. wheels, the new engines had swing link bogies with wheels 3ft. 0½in. diameter, a design for which Sir John, following A. McDonnell, brought over from Ireland. The swing links were of the upper single pin type. The weight on each wheel was transferred through a yoke above the axle-box to two spiral springs on each side of the box, the whole arrangement being similar to that subsequently used by H. A. Ivatt for the bogies of Great Northern engines. Double spiral springs were used for all wheels of these L. and Y.R. engines. Sir John Aspinall used Joy's valve gear for reasons previously mentioned, and it remained standard on the line until quite recently. He also

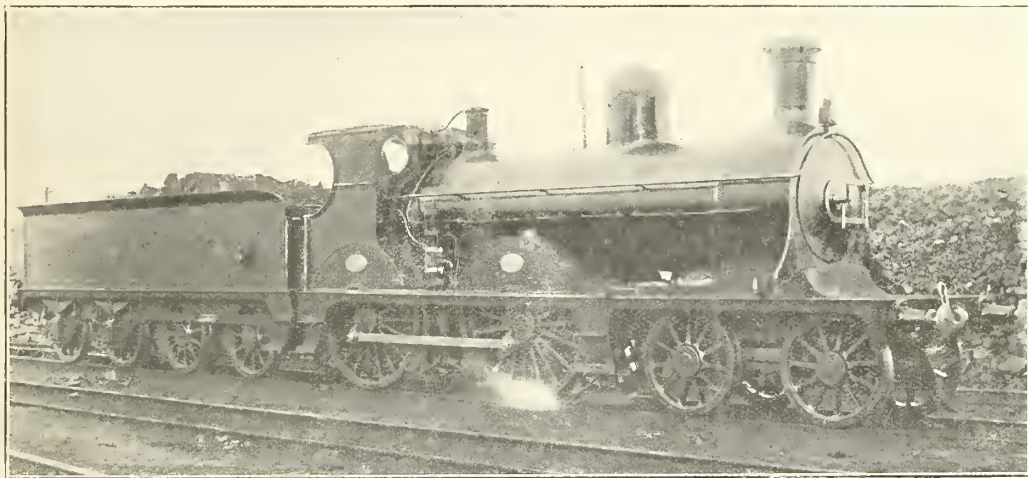

FIG. 342—J. MANSON'S ENGINE WITH BOGIE TENDER, GREAT NORTH OF SCOTLAND RLY., 1890

took the place of the usual brick arch, which was absent, and had been in use on the Great North of Scotland Railway ever since Clark introduced the system about 1858. In later engines the steam inducing jets had been discarded, the air being drawn in through sixteen short tubes, by the action of the ordinary blower. The tubes were arranged, eight in the front and eight in the back wall of the fire-box on a level about 9in. below the fire-hole. Clark's system was stated to have always given good results. The bogies of these engines were of the swing link type, with double pins at the top, on the system known in America as "heart-shaped" hangers, the effect of which is to keep the front end of the engine, when lifted, parallel with the rails instead of tilting it. Although swing links with hangers of this type had previously been freely used by locomotive building firms, this appears to have been their first application by a British locomotive superintendent.

Sir John Aspinall's 4-4-0 engines for the

introduced cast steel wheels, and raised the boiler pressure from 140 lb. to 160 lb.

Engines of the 0-4-2 Type.—W. Stroudley's celebrated express engines on the London, Brighton and South Coast Railway, the "Gladstone" class—Fig. 343—had leading and driving wheels coupled, of the large diameter of 6ft. 6in. Of these engines, thirty-six were built at Brighton works, 1882-91, the later engines from about 1889 having 150 lb. instead of 140 lb. pressure.

The type was an enlargement of the 1878 design, which also had 6ft. 6in. leading wheels. Stroudley reasoned that the greatest weight was at the front, and therefore he placed the coupled wheels there, shortening the wheel base and dispensing with heavy castings on the footplate end. "The leading wheels pass round curves without shock or oscillations, owing to the small weight upon the trailing wheels, as it is the trailing wheels that have the most influence in forcing the leading flanges up to the outside of the curve" (Stroudley, "Proc." Inst. C.E., March, 1885).

This reasoning is perfectly sound, and certainly Stroudley designed a very powerful engine, which stood on a wheel base of 15ft. 7in., and weighed less than 38½ tons in working order. An objection is the flange wear of the leading tires, which, being of large size, are expensive to re-turn or replace, but it has not generally been noticed that Stroudley in 1882-84 used tires of a tensile strength of 47 to 48 tons per square inch, at a period when the majority of other locomotive engineers were content with 35 to 40 tons per square inch. The treads of the leading tires were coned 1 in 32, and the driving tires, which had very thin flanges, had parallel treads. There does not appear to be any officially recorded case of these engines leaving the rails, which could be attributed to the large leading wheels. The cylinders, 18½in. by 26in., at 2ft. 1in. centres,

successful, but no locomotive engineer in this country imitated the design. The locomotive department of the Ch. de fer du Nord was apparently so impressed by Stroudley's arguments and results that a 0-4-2 express engine on similar lines, also with 6ft. 6in. front coupled wheels, was built at the La Chapelle shops in 1886. But the French engineers did not make a success of it; whereas in Stroudley's engine the coupled wheel base was 7ft. 7in. and the trailing carrying axle was 8ft. behind the driving axle, in the French engine, though the total wheel base was nearly the same, the coupled wheel base was about 8ft. 8in., and the trailing axle was much nearer the driving axle. After running for about a year the engine was converted to a 4-2-2 single, by the substitution of a leading bogie for the front coupled axle.



FIG. 343—W. STROUDLEY'S FOUR-COUPLED EXPRESS ENGINE. "GLADSTONE" CLASS. L.B. & S.C.R., 1882-91 (Photo. Locomotive)

had the steam chests below. The downward inclination towards the crank axle was 1 in 11½, and the upward inclination of the port faces was 1 in 15, the valve spindles passing beneath the leading axle. The design had the defect that the exhaust was in contact with the cylinder walls over a considerable area. The steam pipes to the cylinder were double, one leading to the front and the other to the back of the steam chest. The coupling-rod cranks, as in all Stroudley's engines, were of short throw and on the same side of the axle as the inside cranks, necessitating large balance weights.

Stroudley's 0-4-2 engines were extremely

In 1887 W. Adams, on the London and South-Western Railway, designed the engine of which fifty were built at Nine Elms and forty by Neilson between 1887 and 1895—Fig. 344. The cylinders were 18in. by 26in., and the coupled wheels 6ft. 1in. diameter. These were not express engines, but intended for general traffic, including fast goods trains. They were the first four-coupled tender engines which Adams had designed with inside cylinders, and from 1887 he abandoned outside cylinders for all classes except 4-4-0 express engines. The 0-4-2 engines differed from Stroudley's, in having a considerably longer wheel base of 16ft. 10in. The trailing axles had outside bearings to keep the journals away from the heat of the fire-box, and in this respect revived Beyer, Peacock's old design of 1859—see page 157 *ante*—which had been dormant since

¹ It is interesting to note that the engine "Gladstone" has been reconditioned to its original state and is to be preserved at the L. and N.E. Railway Museum at York.—Ed.

1864. Also, as in Stroudley's engines, the cylinders were arranged with steam chests below, but in the last sixty of the class the steam chests were between, in both cases with the two cylinders cast in one piece.

in 1885. Ten of them were broad-gauge "convertibles" for working west of Newton Abbot, and ten were standard-gauge engines, as illustrated, for working passenger trains through the Severn Tunnel, which was then shortly to be

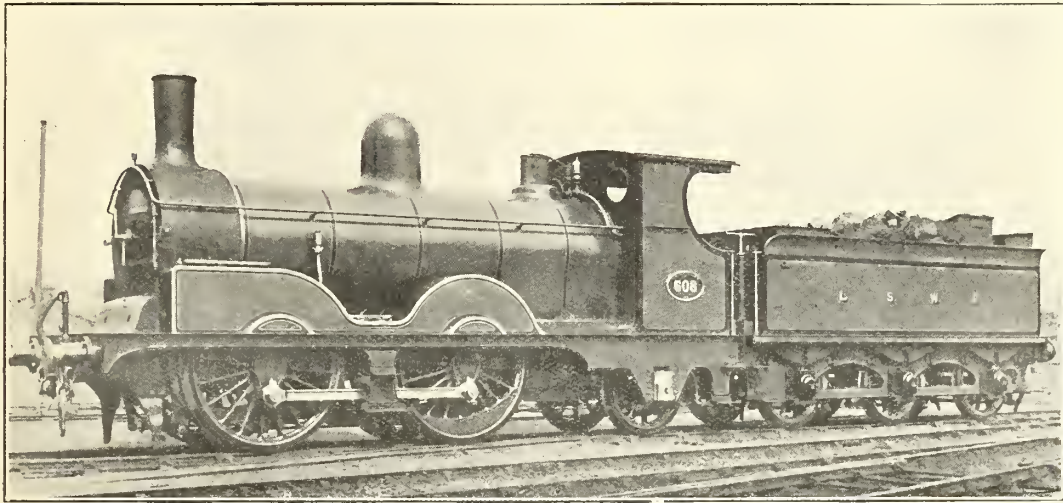

FIG. 344—W. ADAMS'S FRONT COUPLED ENGINE, LONDON & SOUTH-WESTERN RLY., 1887 [Photo. Locomotive

Six-wheeled Passenger Tank Engines.—The six-wheeled passenger tank engine was dying slowly. Stroudley's 0-4-2 tank engines on the Brighton Railway, "D" class—Fig. 258 *ante*—were built until 1887. Drummond had tried six similar engines on the North British Railway in 1877, but they were subsequently converted into 0-4-4 tank engines by his successor. The Great Western was the only other line of importance

opened. For this purpose they were fitted with condensing gear. They came out at a time when double frames had just been revived on the G.W.R., and, with exception of the side tanks, were similar to some 2-4-0 tender engines built at the same time. The outside frames were of solid plates, and the leading spring hangers were of the chain link form. The cylinders were 17in. by 26in.; coupled wheels, 5ft. 1in.; leading wheels,

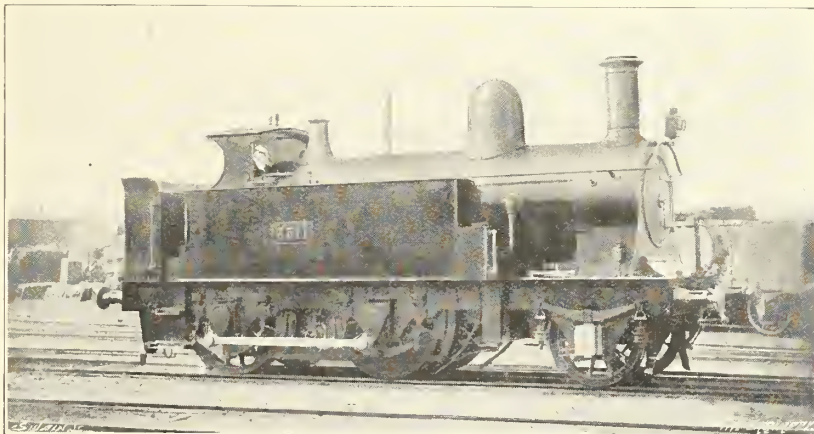

FIG. 345—W. DEAN'S TANK ENGINE, G.W. RLY., 1885 [Photo. Locomotive

which held tenaciously to the six-wheeled engine, of which two unusual types for the period are illustrated.

The 2-4-0 side tank engines with double frames—Fig. 345—by W. Dean, were built at Swindon

4ft. diameter; wheel base, 9ft. 3in. + 7ft. 9in.; the boiler, 4ft. 4in. inside diameter, contained 268 1½in. tubes; total heating surface, 1210 square feet; grate, 15.2 square feet; pressure, 140 lb.; weight in working order, leading 10 tons 5 cwt.,

driving 16 tons 2 cwt., trailing 16 tons 16 cwt., total 43 tons 3 cwt.; empty, 33 tons 18½ cwt. After 1890 they were converted to tender engines.

The 0-4-2 tank engines—Fig. 346—built at Swindon, 1887-89, present several peculiarities.

faces of which were slightly convex. The cylinders were 17in. by 24in., with valves underneath; coupled wheels, 5ft. 1in., and trailing wheels, 4ft. diameter; wheel base, 7ft. + 10ft. 6in.; total heating surface, 1194.6 square feet, of which the



(Photo. Locomotive

FIG. 346—W. DEAN'S TANK ENGINE, G.W. RLY., 1887

The frames were of the double sandwich type, with teak and cast iron blocks. The arrangement at the trailing end—shown by Fig. 347—was of a design which was never used elsewhere. The outer gun-metal axle-boxes, which carried the greater part of the load, were without guides,

fire-box provided 125 square feet; grate area, 18.9 square feet; the boilers were constructed for 180 lb. working pressure, and for a short time they worked thus, but subsequently it was reduced to 160 lb.; the total weight in working order of the earlier engines was 47 tons 18 cwt., of which 32 tons 14 cwt. were available for adhesion, but afterwards the tanks were shortened—as shown by the illustration—and the weight reduced to 45 tons 8 cwt., of which the coupled wheels carried 32 tons 8 cwt.

The trailing axle arrangement allowed too much swaying movement, which was aggravated owing to the long distance, 10ft. 9in., between the middle and trailing axles, and the engines were subsequently modified by the substitution of trailing bogies with Mansell wooden wheel centres. After this alteration the wheel base became 7ft. + 8ft. 1in. + 4ft. 6in., though in the later engines of the type, which had originally a shorter wheel base, the distance from the driving axle to the bogie centre was 9ft. 10in., instead of 10ft. 4in. The weight then became 48½ tons, of which 18 tons rested on the bogie of the longer engines.

In 1895 two of these trailing bogie engines coupled to one train left the road on a curve near Doublebois, and the Board of Trade inspector reported that the permanent way had been distorted by two similar engines working a preceding train. He stated that they were unsuitable for fast trains, which was perfectly true, but further added that other railways had engines of the 0-4-4 type to which similar strictures applied, which was a somewhat inaccurate generalisation. The G.W.R. engines, unlike those of the Midland and other lines, which ran very steadily for years

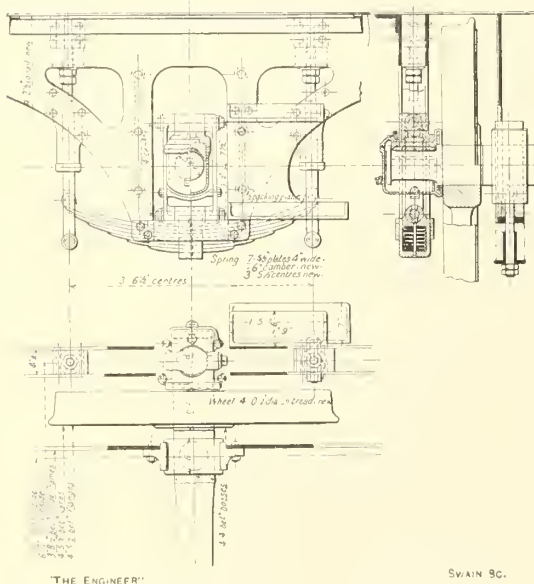

FIG. 347—TANK LOCOMOTIVE TRAILING AXLE, G.W.R.

since there were no hornblocks in the outside frames, and their only connection with the framing lay in the spring hangers, which passed through deep cast iron blocks. The inside axle-boxes had flanges and worked in hornchecks, the

with fast trains, had the coupled wheels bunched together at one end and an unsuitable bogie with a base of only 4ft. 6in. at the other. They were afterwards converted to 4-4-0 tender engines with much longer leading bogies.

Eight-wheeled Tank Engines.—In spite of the disapproval of the Board of Trade inspector of that day, the 0-4-4 tank engine, as introduced in its modern form by S. W. Johnson in 1872, has always been a favourite type on many railways, and has caused very little trouble when properly designed. It was built regularly for British railways up to 1922; it curves very freely, and is probably a steadier engine on fast trains than the 2-4-2 type, which has a tendency to oscillate at both ends, being guided only by the middle coupled wheels. For this reason, the controlling springs of the radial axles of the latter must be very strong, and the radii of the guides of the two end axle-boxes of much greater length than they should be to allow the engine to curve naturally. But the 2-4-2 type has the advantage

dome; total heating surface, 922.5 square feet; pressure, 140 lb.; tank capacity, 1050 gallons; fuel capacity, 30 cwt.; weight in working order, leading 13 tons 17 cwt., driving 16 tons, bogie 18 tons 16 cwt., total 48 tons 13 cwt.

The 2-4-2 tank engine, with radial axles at both ends, made considerable headway during this period and was adopted by several railways. In all cases Webb's type of radial axle-box and, except on the L. and N.W.R., Joy's valve gear were used. T. W. Worsdell's Great Eastern engines of 1884-85, built at Stratford—Fig. 348—had 18in. by 24in. cylinders, 5ft. 4in. coupled wheels, and 3ft. 9in. radial wheels. Wheel base, 7ft. 6in. + 8ft. + 7ft. 6in. The total heating surface was 1054.1 square feet, of which the fire-box supplied 98.4 square feet; grate area, 15.4 square feet; tank capacity, 1200 gallons, weight in working order, 51 tons 18½ cwt., of which 29 tons 2¾ cwt. were available for adhesion; weight empty, 41 tons 13¾ cwt. The radial axle-boxes differed from Webb's in that

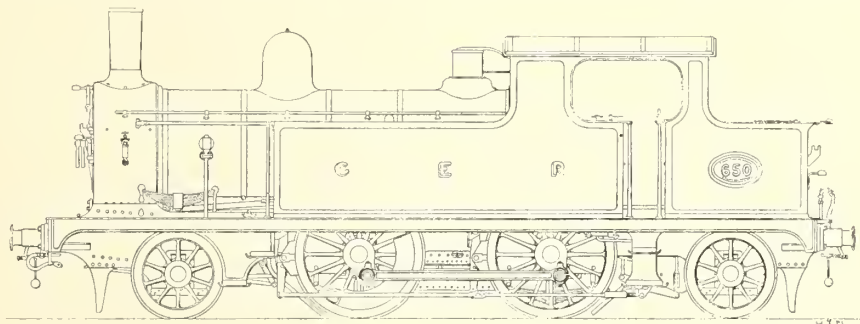

FIG. 348—T. W. WORSDELL'S TANK ENGINE, G.E.R., 1884

of allowing larger water and fuel capacity, and the weight distribution is good.

Most of the 0-4-4 type followed closely on the lines of S. W. Johnson's Midland engines—Fig. 261 *ante*—and had "Adams" bogies with a fair amount of lateral movement and check springs of medium strength. The bogie wheels in most cases were 3ft. in diameter. It will suffice to mention briefly J. Stirling's engines for the South-Eastern Railway—illustrated in *The Engineer*, January 26th, 1894—in which the bogies differed from the usual designs. In his 0-4-4 tank engines of 1881-82, Stirling employed a rigid centre pin bogie, with 3ft. wheels. This does not allow sufficient freedom, and causes the flanges of the leading wheels to wear rapidly. From 1887 onwards a bogie similar to that used for the express engines—Fig. 339 *ante*—with < shaped link and two pins was adopted. It had 3ft. 9½in. wheels, 5ft. 4in. wheel base, and a limited lateral movement of about ¾in. each side, controlled by rubber springs on the arms of the Y. The cylinders were 18in. by 26in., and the coupled wheels 5ft. 6in. diameter. Coupled wheel base, 7ft. 5in.; total wheel base, 22ft. The boiler was without

double elliptical plate springs instead of spiral springs were used to control the lateral movement, and the radius of curvature of the centre line of the curved guides was 13ft. 1½in., that is 1ft. 6in. longer than the distance from the radial axle to the middle point of the rigid wheel base, with allowance of 1½in. for the versed sine of arc of curvature.

These engines, with modifications in details of the motion, were adopted as standard on the G.E.R. by James Holden, who reduced the cylinder diameter to 17½in., substituted Stephenson's link motion for Joy's gear, and used the single slide bar motion in place of the 4-bar motion. As thus modified the type was built at Stratford works until 1911.

T. W. Worsdell also built a similar type on the North-Eastern Railway with 18in. by 24in. cylinders and 5ft. 7in. coupled wheels, and similar dimensions were adopted by T. Parker on the Manchester, Sheffield and Lincolnshire Railway. In these engines the pressure was 160 lb.

Perhaps the best known and largest 2-4-2 tank engines are those designed by Sir John Aspinall, first built at Horwich in 1889, and for about

twenty years subsequently—Fig. 349. For many years these engines have worked the greater part of the passenger traffic on the Lancashire and Yorkshire Railway, and not infrequently have been used on express trains. The cylinders are

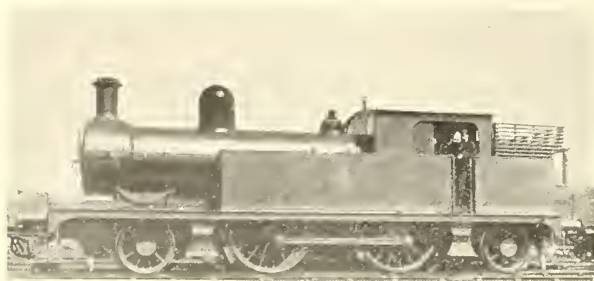

FIG. 349—ASPINALL'S 2-4-2 TANK LOCOMOTIVE, L. & Y. RLY., 1889-1901

18in. by 26in., though a considerable number, built 1892 to 1901, had 17½in. by 26in. cylinders; coupled wheels, 5ft. 7¾in.; radial wheels, 3ft. 7½in. diameter; wheel base, 7ft. 10½in. + 8ft. 7in. + 7ft. 10½in. = 24ft. 4in.; the boiler, which carried 160 lb. pressure, contained 220 1¾in. tubes; tube heating surface, 1108.7 square feet; fire-box, 107.7 square feet; total, 1216.4 square feet; grate, 18.75 square feet. The engines built until 1898 carried 1340 gallons of water and weighed 55 tons 19 cwt. in working order, of which 31 tons 13 cwt. were carried on the coupled wheels, but in those built from 1898 onwards the tanks and bunkers were considerably enlarged, and had a water capacity of 1540 gallons. The weight of this enlarged class in working order is:—Leading, 12 tons 6 cwt.; driving, 17 tons

1¾in. versed sine of arc. The engines were fitted with Aspinall's improved water scoops, which are referred to later.

Of the five leading railways which adopted the 2-4-2 type in 1884-89, two, the Great Eastern and the Lancashire and Yorkshire, made it standard for many years. On the North-Eastern Railway, after 60 of the type had been built, 1886-92, by T. W. Worsdell, it was discarded by his brother, Wilson Worsdell, who in 1894 substituted the 0-4-4 type. On the Manchester, Sheffield and Lincolnshire—Great Central—Railway 49 engines of the type were built down to 1898, but Mr. J. G. Robinson afterwards adopted the 4-4-2 type. On the L. and N.W.R. a large number was built until 1897, when the 2-4-2 type lapsed. On the Great Northern the 0-4-4 type of P. Stirling was replaced in 1898 by the 4-4-2 type.

Ten-wheeled Tank Engines, 4-4-2 Type.—W. Adams, on the London and South-Western Railway, started with the 4-4-0 type with outside cylinders, which has the disadvantage of limited fuel capacity. In 1882 he designed the 4-4-2 type—Fig. 350—the first twelve of which were built by Beyer, Peacock. In all, there were 71 of these engines by this firm and by Stephenson, Neilson, and Dübs, 1882-85. Unlike the Tilbury engines, those of the L. and S.W.R. were intended for local traffic, to replace Beattie's small 2-4-0 engines, then becoming out of date. A large part of the water was carried in the tank at the back, and the side tanks were very short. Single slide bar motion was used. The cylinders were 17½in. by 24in.; coupled wheels, 5ft. 7in.; bogie and radial wheels, 3ft. diameter. In the last twenty engines the radial wheels were 3ft. 6in. in diameter. Wheel base, 7ft. + 6ft. 5in. + 8ft. 6in.

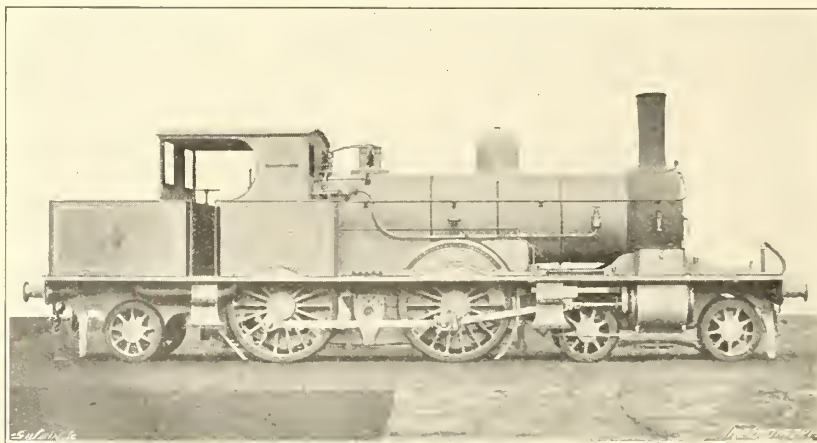

FIG. 350—W. ADAMS'S PASSENGER TANK ENGINE, L. & S.W.R., 1882-85

7 cwt.; coupled, 17 tons 8 cwt.; trailing, 12 tons 2 cwt.; total, 59 tons 3 cwt. The radial axle-boxes have spiral controlling springs underneath the curved guides, and the curve of the latter is struck from the centre of the coupled wheel base plus

+ 7ft. 6in. = 29ft. 5in. The boiler contained 201 1¾in. tubes, which had a heating surface of 944.7 square feet; total heating surface, 1055.9 square feet; grate area, 18 square feet; pressure, 160 lb.; tank capacity, 1000 gallons; total length

over buffers, 38ft. 8 $\frac{1}{2}$ in. The total lateral movement of both bogie and radial axle was 2 $\frac{1}{2}$ in. Weight in working order:—Bogie, 14 tons 14 cwt.; driving, 15 tons 16 cwt.; coupled, 15 tons; trailing, 8 tons 12 cwt.; total, 54 tons 2 cwt. These engines had a large proportion of non-adhesive weight, and in 1888 W. Adams discarded them for the 0-4-4 type with 18in. by 26in. inside cylinders; 5ft. 7in. coupled wheels; 1231 square feet of heating surface; and 160 lb. pressure. The total weight of these engines is 53 tons, of which 35 tons 3 cwt. are carried on the coupled wheels. This 0-4-4 design represented a much more powerful engine of 1.1 tons less total weight, and 4.65 tons more adhesion.

The first 4-4-2 tank engines with inside cylinders—Fig. 351—were built by the Vulcan Foundry in 1888 for the Taff Vale Railway, to the designs of T. Hurry Riches, and initiated a type which has more recently become very exten-

sively used. The cylinders were 17 $\frac{1}{2}$ in. by 26in., inclined downwards, and with slide valves above, these being balanced by circular rings. Bogie wheels, 2ft. 9in.; coupled wheels, 5ft. 3in. and trailing radial wheels, 3ft. 8 $\frac{1}{2}$ in. diameter; wheel base, 5ft. 9in. + 6ft. 11 $\frac{1}{2}$ in. + 7ft. 10in. + 6ft. = 26ft. 6 $\frac{1}{2}$ in. The boiler contained 214 brass tubes, 1 $\frac{3}{4}$ in. diameter, of which the heating surface was 1116.7 square feet; total heating surface, 1212.7 square feet; grate, 19 square feet; pressure, 160 lb.; tank capacity, 1600 gallons; fuel capacity, 2 $\frac{1}{2}$ tons. Weight in working order:—Bogie, 14 tons; driving, 15 $\frac{1}{2}$ tons; coupled, 15 $\frac{1}{2}$ tons; trailing, 9 tons; total, 54 tons. The valves were actuated by Stephenson's link motion and rocking shafts. The trailing radial-boxes were, as in Webb's type, connected across the engine by a hollow casting, but this, unlike the latter, was straight and not curved. The guides had straight inclined surfaces with clearance between them and the axle-boxes such that the movement of the axle could take place about a virtual centre 6ft. 2in.

from the centre of the bearing. The controlling spiral spring was placed behind the axle-box, a position in which it is not so liable to damage as when placed below, as in Webb's system. The blast pipe orifice was somewhat similar in section to a Venturi tube.

Goods Engines, 0-6-0 Type.—It is unnecessary to describe in detail the general designs of goods engines, which on most lines were very similar to one another. Most of them had wheels varying from 4ft. 10in. to 5ft. 2in. diameter, and cylinders 17 $\frac{1}{2}$ in. or 18in. by 26in. stroke. The Great Western Railway in 1883 temporarily adopted the usual British inside framed type, but adhered to 17in. by 24in. cylinders, and the Great Eastern Railway also retained the old 17in. or 17 $\frac{1}{2}$ in. by 24in. dimensions. The pressure was usually 140 lb. to 160 lb. The few engines described below have been selected on account of special features of interest.

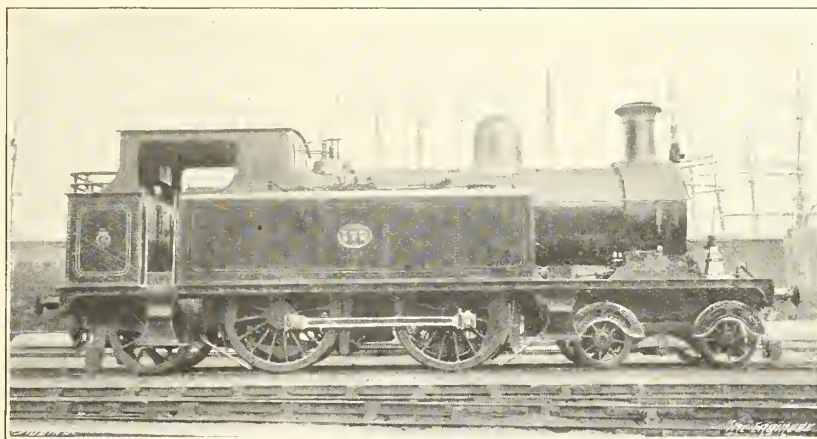

[Photo. Locomotive

FIG. 351—T. HURRY RICHES' PASSENGER TANK ENGINE, TAFF VALE RLY., 1888

sively used. The cylinders were 17 $\frac{1}{2}$ in. by 26in., inclined downwards, and with slide valves above, these being balanced by circular rings. Bogie wheels, 2ft. 9in.; coupled wheels, 5ft. 3in. and trailing radial wheels, 3ft. 8 $\frac{1}{2}$ in. diameter; wheel base, 5ft. 9in. + 6ft. 11 $\frac{1}{2}$ in. + 7ft. 10in. + 6ft. = 26ft. 6 $\frac{1}{2}$ in. The boiler contained 214 brass tubes, 1 $\frac{3}{4}$ in. diameter, of which the heating surface was 1116.7 square feet; total heating surface, 1212.7 square feet; grate, 19 square feet; pressure, 160 lb.; tank capacity, 1600 gallons; fuel capacity, 2 $\frac{1}{2}$ tons. Weight in working order:—Bogie, 14 tons; driving, 15 $\frac{1}{2}$ tons; coupled, 15 $\frac{1}{2}$ tons; trailing, 9 tons; total, 54 tons. The valves were actuated by Stephenson's link motion and rocking shafts. The trailing radial-boxes were, as in Webb's type, connected across the engine by a hollow casting, but this, unlike the latter, was straight and not curved. The guides had straight inclined surfaces with clearance between them and the axle-boxes such that the movement of the axle could take place about a virtual centre 6ft. 2in.

The Great Eastern Railway engines—Fig. 352—of which there were only ten, made by Kitson, 1882, were designed by Massey Bromley. They had the peculiarity that the platforms were raised, as shown, above the wheels, and doors were provided on the left-hand side at the front of the cab to allow the driver access to the platform. For engines with inside cylinders the arrangement rendered the motion somewhat more difficult to oil. The coupling-rods had plain bushes for the leading and trailing wheels, but double cottered brasses for the driving wheels. Compensating levers connected the leading and driving springs. The cylinders were 17in. by 24in.; wheels, 5ft. 2in. diameter; wheel base, 7ft. 7in. + 7ft. 11in.; the heating surface of 203 1 $\frac{3}{4}$ in. tubes was 957.6 square feet; total, 1052.5 square feet; grate area, 15.27 square feet; pressure, 140 lb.; weight in working order, 36 tons 3 $\frac{1}{2}$ cwt.

W. Stroudley's heavy goods engines of 1882-87 for the Brighton Railway had 18 $\frac{1}{2}$ in. by 26in. cylinders, 5ft. wheels, and 150 lb. pressure. The

cylinders and motion were similar to those of the 0-4-2 express engines. Tube heating surface, 1312 square feet; fire-box, 101 square feet; total, 1413 square feet; grate, 20.95 square feet; total weight, 40 tons 7 cwt. in working order. The six engines

outside *underhung* springs, the only instance within the writer's recollection of such a combination in six-coupled engines. They had 17in. by 26in. cylinders; 5ft. 1in. coupled wheels; wheel base, 7ft. 9in. + 8ft.; heating surface, 1157

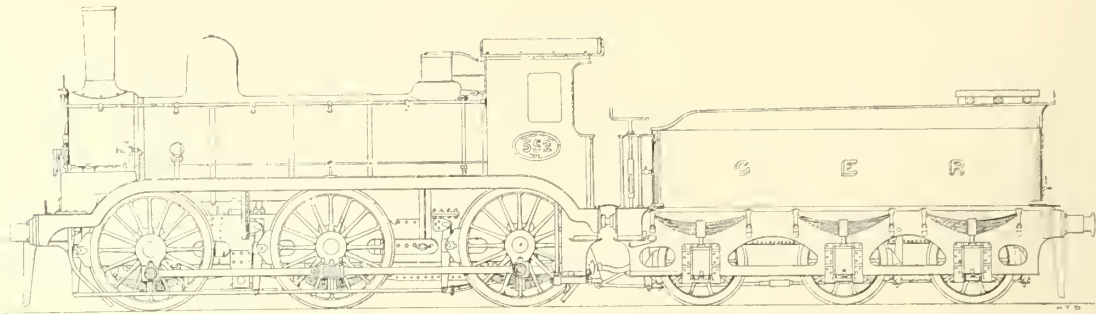

FIG. 352—M. BROMLEY'S GOODS ENGINE, GREAT EASTERN RLY., 1882

of 1887 had an air reversing cylinder inside the cab. Their outward appearance was very similar to the earlier engines—Fig. 265 *ante*.

The Great Western goods engines of 1883-84 by W. Dean had 17in. by 24in. cylinders and 5ft. 1in. coupled wheels; wheel base, 7ft. 3in. + 8ft. 3in. The first twenty had domeless boilers in accordance with Swindon practice of 1881-83, but in the 1884 engines the boilers had large domes on the front ring of a steel barrel made in two rings. The total heating surface was 1192.7 square feet; grate area, 16.4 square feet; pressure, 140 lb.; total weight in working order varied from 32½ to 33¼ tons. The coupling-rods were made with a double knuckle joint. The end of the front rod terminated in a joint with a vertical pin to allow horizontal movement on curves; the back rod had the usual vertical motion about a hori-

square feet; grate area, 15.2 square feet; pressure, 140 lb.; weight in working order, 36 tons 18 cwt., equally distributed on each axle; weight empty, 33 tons 18 cwt. These were the last 0-6-0 tender engines on the G.W.R. with double frames, and from 1890 to 1898 the 1883 design with greater tube heating surface was re-adopted.

One G.W.R. goods engine, built 1882 at Swindon, had 17½in. by 28in. cylinders, Joy's valve gear, and domeless boiler. Originally constructed as a 0-6-0 side tank engine, it was found that the variation of weight on the springs as the water in the tanks diminished affected the valve gear, and in 1884 it was converted into a tender engine. This engine, No. 1833, was the only engine with Joy's gear built for the Great Western.

Sir John Aspinall's standard 0-6-0 engines on the Lancashire and Yorkshire Railway—illus-



FIG. 353—W. DEAN'S GOODS TANK ENGINE, G.W.R., 1882-84 [Photo. Locomotive]

zontal pin. This joint is shown in the illustration of the 0-6-0 tank engine—Fig. 353. In 1885 this form of coupling-rod was discarded.

In 1885-86 twenty 0-6-0 engines—Fig. 354—were built at Swindon, having double frames and

trated by the plate in *The Engineer*, January 1st, 1892—also had Joy's valve gear. The class was built continuously at Horwich works from 1889 to 1909, and subsequently with superheaters, larger cylinders and a few other modifications by

Mr. G. Hughes. The cylinders are 18in. by 26in., with valves above; wheels, 5ft. 0 $\frac{7}{8}$ in. diameter; wheel base, 7ft. 9in. + 8ft. 7in.; the boiler contained 220 1 $\frac{3}{4}$ in. copper tubes, of which the heating surface was 1102.2 square feet; total,

Company. They are illustrated in Fig. 355. The outside cylinders were 20in. by 26in.; diameter of coupled wheels, 4ft. 3in.; total wheel base, 15ft. 5in. The boiler barrel, 12ft. 7in. long by 4ft. 5in. diameter, contained 192 2in. tubes, of



FIG. 354—W. DEAN'S GOODS ENGINE, G.W. RLY., 1885-86

{Photo. Locomotive

1209.9 square feet; grate, 18 $\frac{3}{4}$ square feet; pressure, 160 lb.; weight in working order, leading 13 tons 16 $\frac{1}{2}$ cwt., driving 15 tons, trailing 13 tons 6 $\frac{1}{2}$ cwt., total 42 tons 3 cwt.; weight empty 38 tons 3 cwt.

Eight-wheels Coupled Tender Engines.—The two first main line 0-8-0 tender engines to run in this country* were put into service on the Barry Railway in 1889. Originally they had been designed and built in 1886 by Sharp, Stewart at

which the heating surface was 1205 square feet; total heating surface, 1320 square feet. Two more of these engines were purchased from Sharp, Stewart in 1897, and subsequently the cylinders were reduced to 18 $\frac{1}{2}$ in. by 26in., and they were otherwise modified as shown in Fig. 356. The Stephenson's link motion was inside, and actuated vertical slide valves in accordance with the usual British practice of that day.

Six-wheels Coupled Tank Engines.—The 0-6-0

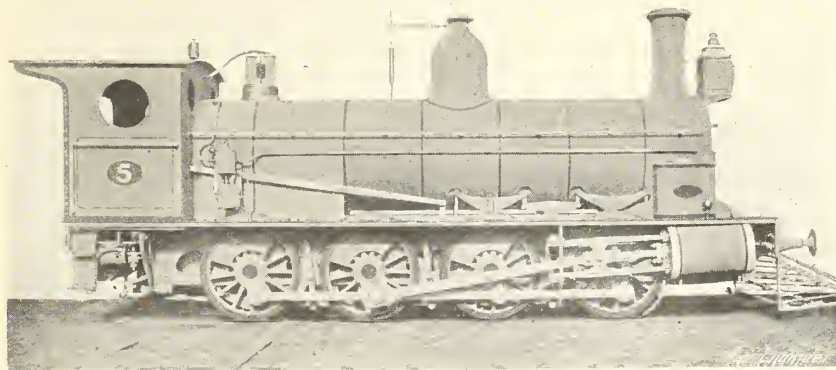

FIG. 355—SHARP, STEWART'S 8-COUPLED ENGINE, AS BUILT FOR THE SWEDISH AND NORWEGIAN RLY., 1886

Manchester for the Swedish and Norwegian Railway, but some were acquired by the Barry

side tank engines of the Great Western Railway—Fig. 353—were built in 1882-84 for main line coal trains between Swindon and Aberdare, and are illustrated, since they show the coupling-rods with double knuckle joints referred to previously. The cylinders were 17in. by 24in.; diameter of wheels, 4ft. 6in.; pressure, 140 lb. The illustration shows

* A 0-8-0 tender engine of small size was designed and probably built about 1850-54 by Stubbs of Llanelly. Very little is known of it beyond a diagram in D. K. Clark's "Railway Machinery," but it may have worked on one of the local mineral railways in South Wales.

an engine with raised smoke-box of the angle ring pattern, but originally all these and other engines built at Swindon, 1881-86, had flush drumhead type smoke-boxes. It was found that the decrease

principal features of the North London engines are the horizontal outside cylinders, single slide bars, and cast iron wheels of the Webb type. The boiler and tubes were of steel, and the fire-box side



[Photo. Locomotive

FIG. 356—SIARP. STEWART'S 8-COUPLED GOODS ENGINE, AS MODIFIED FOR THE BARRY RLY., 1889-97

in the capacity which resulted from the drumhead pattern caused a somewhat uneven pull on the fire, and after 1886 a return was made to the older angle-ring raised pattern.

The North London Railway 0-6-0 tank engines—Fig. 357—by J. C. Park, Bow Works, 1879-94, with outside cylinders, is of a type which, though

stays, which were drilled and drifted at each end, were of soft basic steel, $\frac{7}{8}$ in. diameter at the threads and $\frac{11}{16}$ in. diameter in the body. The slide valves inside the frames were vertical, and the valve rods bent in the form of a horseshoe to clear the leading axle. The cylinders were 17 in. by 24 in.; wheels, 4 ft. 4 in. diameter; wheel base,

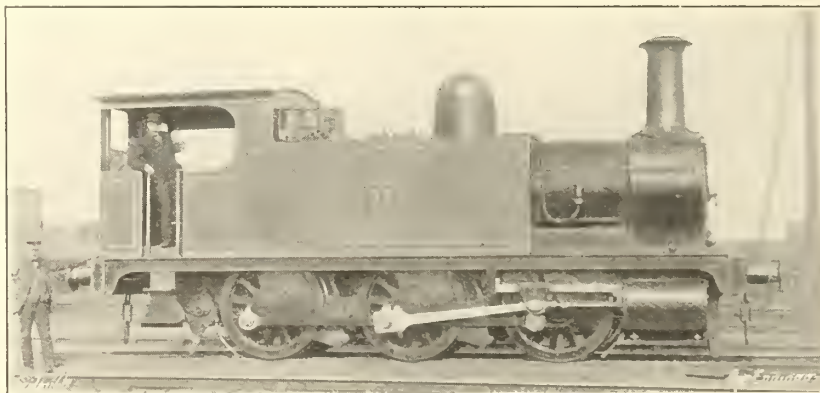

[Photo. Locomotive

FIG. 357—J. C. PARK'S GOODS TANK ENGINE, NORTH LONDON RLY., 1879-94

not so far illustrated, had previously been built in large numbers for ironworks and collieries, but was not often used on main railways, and then only for shunting engines of small size. The

5 ft. 8 in. + 5 ft. 8 in.; tube heating surface, 875.8 square feet; total, 956.8 square feet; grate, 16.3 square feet; pressure, 160 lb.; the weight in working order was very evenly distributed as

follows:—Leading 14 tons $12\frac{3}{4}$ cwt., driving 14 tons 13 cwt., trailing 14 tons $12\frac{3}{4}$ cwt., total 43 tons $18\frac{1}{2}$ cwt.; weight empty, 34 tons 11 cwt.; the tank capacity was 956 gallons.

The Mersey tunnel railway was opened in January, 1886. Exceptionally powerful engines

$19\frac{1}{2}$ in. by 26 in., were outside, and the end axles were pony trucks with radius bars. The coupled wheels were 4 ft. $7\frac{1}{2}$ in.; and the truck wheels, 3 ft. diameter. The boiler barrel was 10 ft. 2 in. long by 4 ft. 6 in. diameter; heating surface of tubes, 1035.5 square feet; of fire-box, 113.8 square feet;

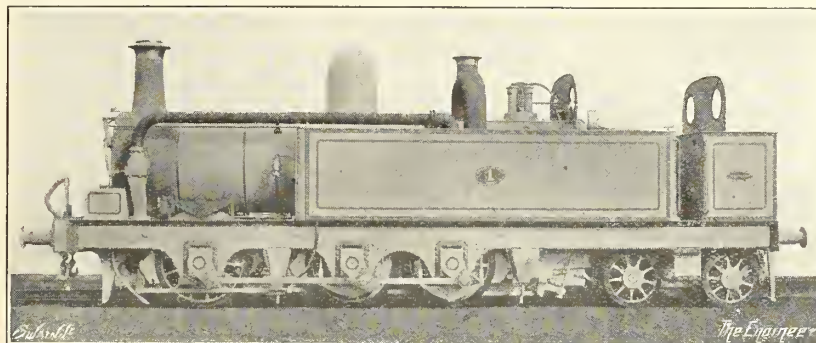

FIG. 358—BEYER, PEACOCK & CO'S TANK ENGINE FOR MERSEY RAILWAY, 1885

for the passenger trains were required to negotiate the gradients of 1 in 27 and 1 in 30 with trains weighing 150 tons net. The first nine engines—Fig. 358—designed and built by Beyer, Peacock, 1885-86, were of the 0-6-4 side tank type, with double frames. The inside cylinders, 21 in. by 26 in., were then the largest in this country. The valves were underneath. J. Stirling's steam reversing gear was fitted. The coupled wheels were 4 ft. 7 in. and the bogie wheels 3 ft. diameter; the boiler barrel, 14 ft. 3 in. long by 4 ft. 7 in. diameter, contained 199 2 in. tubes, giving a heating surface of 1516.2 square feet; total heating surface, 1634.2 square feet; grate, 21 square feet; pressure, 150 lb. The total weight in working order was 67 tons $17\frac{1}{4}$ cwt., of which 16 tons $5\frac{1}{4}$ cwt. were carried by the bogie; tank

total, 1149.3 square feet; grate area, $24\frac{1}{2}$ square feet; pressure, 150 lb.; the wheel base was 8 ft. + 5 ft. 9 in. + 5 ft. 9 in. + 8 ft. = 27 ft. 6 in. The tank capacity was 1382 gallons, but, when working, not more than 1150 to 1170 gallons were used, in order to leave air space. The total weight was $62\frac{1}{2}$ tons in working order, of which 44 tons 7 cwt. were available for adhesion.

It was found in working that the ordinary American type of pony truck with pivoted frame was not very suitable, since the sudden vertical shocks when meeting the 1 in 27 rise caused occasional breakages of the triangular radius bars, and the last three 2-6-2 tank engines by Kitson, 1892, were specially ordered to be made with radial axles. To obtain clearance for a total lateral movement of no less than 7 in. part of the

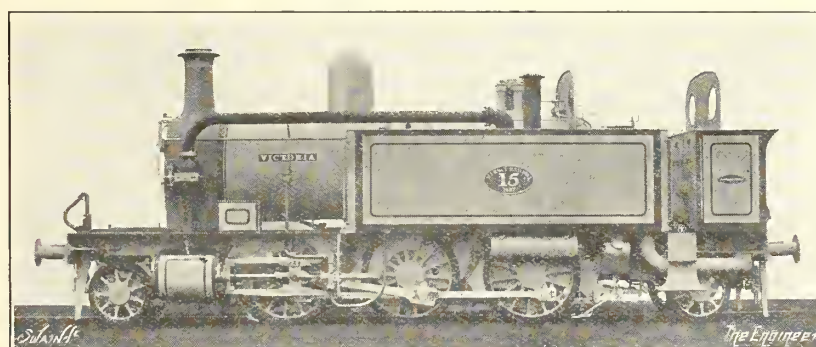

FIG. 359—BEYER, PEACOCK & CO'S TANK ENGINE FOR MERSEY RAILWAY, 1887

capacity, 1250 gallons, with 8 in. of air space above. The engines were provided with condensing apparatus.

A second lot of six engines—Fig. 359—by Beyer, Peacock, 1887, were the earliest 2-6-2 tank engines on any British railway. The cylinders,

main frames were completely cut away behind the wheels and a deeply dished casting with curved guides riveted to them on the inside. The check springs were placed in front of and behind the leading and trailing axle-boxes respectively, as in the Taff Vale engines described previously.

To obtain strength combined with elasticity to resist shocks, the laminated springs above the radial axles were combined with helical springs, which ordinarily came into action when the gradient suddenly changed. The fire-boxes of these, as well as of the 2-6-2 engines by Beyer, Peacock, were carried over the hind coupled axles, and a deeply sloping grate was provided. The engines by Kitson differed from the others in having a drum-shaped extension to the smoke-box similar to that designed by H. Smellie on the Glasgow and South-Western Railway. When fully loaded Kitson's engines weighed 67 tons 9 cwt., of which the leading radial axle carried 9 tons 6 cwt., and the trailing radial axle 12 tons 13 cwt., the adhesive weight being 45 tons 10 cwt.



[Photo. Locomotive

FIG. 360—KITSON'S TANK LOCOMOTIVE, CARDIFF RLY., 1898

0-4-0 Shunting Engines with Kitson's Valve Gear.—A number of small tank engines was supplied by Kitson in 1886 for shunting at the Hull Docks of the Hull and Barnsley Railway. Two others, but with saddle instead of side tanks, were made for the Cardiff Docks in 1898-99, one of which is shown by Fig. 360. The cylinders were 14in. by 21in., with steam chests on the top, and the wheels were 3ft. 2in. diameter. The chief feature was J. Hawthorn Kitson's valve gear, in which the lap and lead movement of the valve was derived from the crosshead and combination lever, similar to that of the Walschaerts gear, but instead of actuating a slotted link by means of a return crank and excentric rod, the travel movement was derived from the coupling-rod, to the end of which a nearly vertical rod was attached. The upper end of this rod received a reciprocating movement in a vertical arc. It was attached to a lever which caused the quadrant link to oscillate about a central trunnion. This gear, in a slightly modified form, was used chiefly on tramway locomotives.

DETAILS OF CONSTRUCTION.

Boilers.—By the end of 1889 steel was rapidly displacing wrought iron for boilers, though it had

not then definitely established a superiority in quality. The writer examined a number of steel boilers made in 1882-86, and found several of them very badly pitted at the end of about six years' service in spite of the fact that steel tubes were used. Even a few years afterwards the head of one of the locomotive building firms told the writer that, unless otherwise specified, he used Yorkshire iron, owing to the number of complaints received in regard to steel. Increased pressures, in addition to reduction in weight and cost, were the main causes of the disappearance of wrought iron. With the use of steel it became more common to make the barrels in two instead of three rings. D. Drummond, when on the North British Railway in 1876, was one of the first to construct his boilers, though of wrought iron, in this way, and was also one of the few whose boilers of this material were pressed at 150 lb. W. Adams, until about 1886, also used Low Moor iron boilers of $\frac{1}{2}$ in. plate in two rings, though pressed at 160 lb. The two-ringed steel boiler was adopted in 1882 by W. Dean on the Great Western Railway for 140 lb. pressure, but several other engineers, such as Webb, Johnson and Aspinall, though using steel boilers and pressures of 160 lb. and upwards, retained three rings.

In 1882 M. Atock, locomotive superintendent of the Midland Great Western Railway, Ireland, constructed a boiler the barrel of which was connected to the smoke-box tube-plate by means of a \cap -shaped ring to allow for the difference between the expansion of brass tubes and that of the iron barrel. The smoke-box tube-plate and fire-box casing back plate were stayed by T irons placed transversely. The \cap -shaped ring lasted seven years, after which grooving started, and in subsequent boilers Atock substituted a flexible corrugated connecting-ring about 1ft. 9in. long.

In 1883 T. W. Worsdell introduced cast steel fire-box girders of 1 section on the Great Eastern Railway. They were made by Messrs. Hadfield.

Blast Pipes.—In 1885 W. Adams introduced his "vortex" blast pipe on the London and South-Western Railway. It had an outer annular orifice for steam, and an internal circular opening for gases formed the upper portion of a bell-mouthed scoop, the lower end of the latter being open towards the bottom rows of tubes, so that the draught through them was increased. The annular jet did not of itself constitute a novelty; annular orifices had been used since 1874 by W. Brown, of Winterthur, on Swiss locomotives. They were recommended by Sir W. Siemens before the Inst. Mech. Engineers in 1872.

"Petticoat" blast pipes were stated by J. F. Robinson, of Sharp, Stewart and Co.—"Proc." Inst. Mech. Engineers, 1872—to have been used in the early days of locomotives, and his description agrees with the form in which one or more open cones were fixed between the blast pipe top

and the base of the chimney.³ Apparently they then disappeared in this country. Ross-Winans used them in America as early as 1848, and in 1854 they had there become general in wood-burning engines. An arrangement with short blast pipe, identical with Ross-Winans's early design, was illustrated in *The Engineer* of July 26th, 1878. One or two were experimentally tested on the Great Western Railway in 1888, when they made what seem to have been their first practical revival in this country.

Blast pipes with variable orifices had died out and were rarely used. W. Kirtley in 1877 fitted some of the London, Chatham and Dover engines with the French "Polonceau" type of top with hinged flaps worked from the foot-plate. Although extensively used on the Continent they were not a success over here, and were abandoned.

The recorded history of blast pipes is very scanty. A search through the patent records would result in the discovery of many schemes, some of which were probably tested. Locomotive superintendents made frequent experiments, the results of which may be buried in such of the archives of their departments as have not been destroyed. Very much more is known of Continental and American designs than of those tried in this country.

Ashpan Dampers.—Most tender engines had front dampers only. Stroudley on the Brighton line used back dampers only. On the Great Western both front and back dampers were provided, and whenever possible the drivers ran with the back dampers opened, using the front dampers only in case of heavy working and bad coal. This excellent system does not seem to have been universally appreciated, and many modern tender engines are still unprovided with back dampers.

Frames.—It will be observed that double plate frames were by no means defunct, though only three British railways were now building engines of this type with four bearings for the driving axle. Since the early days of railways there had been no examples of the construction used on the Continent, notably in Belgium and France, in which there were two outside frames only, with a single centre stay, giving three bearings in all. The Gooch 8ft. singles on the G.W.R. broad gauge, which remained at work until May, 1892, had five bearings for the crank axle. W. Dean's double-framed engines from 1885 onwards not only had four bearings for the driving but also for the other axles.

On the Manchester, Sheffield and Lincolnshire Railway Charles Sacré used double frames

³ Warren ("A Century of Locomotive Building," page 276) mentions that in some early engines of R. Stephenson and Co., circa 1832, the blast pipe was placed lower than the top of the smoke-box and the chimney prolonged downwards into the latter. The four-coupled "Planet" type model 1833, in the Conservatoire des Arts et Metiers, Paris, has the nozzle at the bottom row of tubes, the chimney being provided with a petticoat as in modern practice.

exclusively until the end of 1868, when he adopted single inside frames, and all engines built until 1873-74 were of the latter type. But it was found that on this hilly road with severe gradients the inside-framed engines at that time did not stand up to the heavy work as well as those with double frames, and were more frequently in the shops. Therefore, from 1873-74 until 1888 all passenger and goods engines were built with double frames and four bearings for the driving axle. The advantages attained were larger bearing area, and considerable saving in the less frequent breakage of frames. The late Joseph Tomlinson supported these claims for double frames, and added that better springs could be provided, for which there was often insufficient room in inside-framed engines. The greater width between spring centres gave greater stability.

W. Dean, on the G.W.R., after building many single inside framed engines during 1881-84, returned to double frames, except in the case of the 0-6-0 tender and tank engines of 1890-1900, which had inside frames only, principally on account of the saving of cost. The engines of 1887-89 had outside sandwich frames, but from 1891 onwards only solid plate frames were used, and 4-4-0 and 2-6-0 engines of this type were built, the former until early in 1910.

S. W. Johnson, of the Midland, told the writer that he considered double frames preferable for single driving wheel engines, owing to the greater bearing area. In his 4-2-2 engines of 1887 the inside bearings were 7½ in. diameter by 7¼ in. long, and the outside bearings 6¾ in. diameter by 9 in. long. But the 4-4-0 engines, in which the cylinders, 18 in. by 26 in., as in the 4-2-2 engines, were placed at 2ft. 4 in. centres, had inside bearings only, 7½ in. diameter by 7 in. long. Johnson built no coupled engines on the Midland with outside bearings. Beyer, Peacock built all four-wheels coupled engines for the Dutch State Railways with double frames from 1880 until the end of 1906.

On the other hand, double-framed engines were more costly, and for a given power considerably heavier, the difference in weight in the case of Great Western 0-6-0 tender engines of approximately equal power being about 3 to 3¼ tons.

It is also the general opinion that there is greater liability to breakage of crank axles. This is probably true, though no comparative figures to show the extent of the difference in otherwise generally similar engines appear to have been published. But there have been many cases of double-framed passenger engines of which the crank axle mileage exceeded 400,000 on heavy work. Further, should an axle break there is less liability for the engine to leave the rails, especially if the fracture occurs in the journal or close to the wheel seat. The writer remembers two cases of broken crank axles of inside-framed express engines in which the driving wheels came right out. Another argument brought against double frames was their stiffness on curves. It is open to

doubt whether the flexibility of an inside-framed or any engine should depend in any way on the frames, and many frame breakages could probably be traced to this cause. Sufficient play should be allowed in the axle-boxes, and this was usually the case in a well-built double-framed engine, though there were cases in which the amount of play was excessive. But the double-framed engine is now obsolete as regards new construction; it has done excellent service in its day, as witness the wonderful work done by the Midland "800" and other classes and the later G.W.R. engines. The maximum authentic speed ever recorded, over 102 miles per hour, was made by a Great Western double-framed 4-4-0 engine.

Motion Plates, Frame Stays, Brackets, etc.—Steel castings in place of wrought iron plates and angle irons were introduced by F. W. Webb in 1880, and his example was followed by T. W. Worsdell on the G.E.R. in 1882. The writer is unable to state whether the use of cast steel by private locomotive builders ante-dated its introduction on British railways. The reversing shafts of Joy's gear were always of cast steel. Cast steel hornblocks had been used by A. McDonnell in Ireland as far back as 1873.

The motion plates of Worsdell's engines by Messrs. Hadfield contained .38 per cent. of manganese.

Bogies.—The principal novelty was T. W. Worsdell's bogie, which appeared on the N.E.R. in 1887, and subsequently became standard on that line. The centre pin entered a block which moved between curved instead of straight slides, as in the Adams type, and the controlling plate springs were of the double elliptical form. At the front the bogie frames were fitted on their outsides with buffing blocks, which limited the extreme movement by coming into contact with the main frames. The radius of curvature of the slides was 10ft., the centre coinciding with the centre of the driving axle, the intention of the design being to prevent the rotation round the pin and transfer it to the slides. Whether the extra expense of curving the slides compensated for friction and wear on the pin is doubtful. The arrangement was, in effect, a combination of the Adams bogie and Webb radial axle-box.

Wheels, Axles and Springs.—Cast steel for wheel centres rapidly supplanted wrought iron. When, and on what railway, they were first used the writer has been unable to trace, but Messrs. Hadfield, of Sheffield, had made cast steel driving wheels prior to 1884, and Mr. Robert Hadfield had for many years urged locomotive engineers that safety and durability could be secured by their adoption. The first cast steel driving wheels in this country which it has been found possible to trace were made by Messrs. Hadfield for ten of T. W. Worsdell's 2-4-2 tank engines on the G.E.R. The wheel centres were 4ft. 10in. diameter and the wheels 5ft. 4in. diameter on tread. The Midland also used a few in 1884. At the end of

1884 F. W. Webb introduced steel on the L. and N.W.R. for the small 3ft. 9in. leading wheels of the "Dreadnought" compound engines, and at the end of 1885 was using it for 6ft. 3in. driving wheels. T. W. Worsdell, on the G.E.R., in 1883 provided some express engines with Hadfield's patent cast steel carrying wheels, in which the treads were solid with the centres, and separate tires were not used. The treads were neither forged, hammered nor rolled. An official record stated that a pair of these wheels, taken at random from the lot, had run over 122,000 miles, and had worn only $\frac{3}{4}$ in. They ran under express engines between London and Harwich at speeds of 50 to 60 miles per hour, each wheel carrying $4\frac{1}{2}$ tons. The durability was stated "to be fully equal to that of the best rolled crucible steel tires." When worn they could be re-turned and ordinary tires put on. The wheel diameter was not stated, but the weight corresponds to that on the 3ft. 8in. carrying wheels of the Sinclair 2-2-2 express engines, some of which were still working the Harwich expresses.

In 1889 S. W. Johnson built his express engines with cast steel driving wheels, 7ft. 6in. diameter over tires. The steel had a tensile strength varying from 26 to 32 tons per square inch, with an elongation of about 24 per cent. in a length of 2in. The yield point was about 18 tons per square inch.

Tire fastenings were modified on certain railways to replace the studs, the holes for which were considered to constitute a source of weakness. In the Carlton and Stroudley fastening used on the Great Western locomotives, a turned and cut ring is sprung into a groove and secured by hammering the outer lip of the latter on the ring. T. W. Worsdell on the G.E.R. from 1884 and on the N.E.R. from 1886 onwards drilled the rims of the cast steel wheels transversely and secured the tires by a modification of Mansell's carriage wheel fastening, with one retaining ring having two lips, which fitted into recesses on the inside of both wheel and tire. The whole was secured by transverse countersunk rivets.

The Penistone accident of 1884, which was caused by a broken crank axle, brought about the revival of the old method of putting a bolt longitudinally through the crank pin. The axle in question broke through the web, which was not hooped. Most of the railways which had not hooped the crank webs now did so; but T. W. Worsdell adopted unhooped webs of circular shape, which also had the advantage that they could be turned in a lathe. He was of opinion that the webs should be thinner and wider than generally used, to give a slight amount of flexibility.

During 1883-85 S. W. Johnson on the Midland cast the excentric sheaves on crank axles, but subsequently abandoned the practice because it made the axles too stiff.

Plate springs for driving axles gave place to

spiral or helical springs, which gave greater uniformity of pressure of the wheels on the rails, owing to their reduced friction. Webb also used them for trailing wheels, for which position they are somewhat too sensitive.

Piston valves were reintroduced in 1887 on the N.E.R. of W. M. Smith's design, and from this time onwards successfully. The valves were made with collapsible segments to afford relief for water trapped in the cylinders. The arrangement of cylinders was improved, and the steam chests placed above or below with direct drive from the excentrics, avoiding the use of rocking shafts. Full description and illustrations of various designs of these valves were given in the "Proc." Inst. Mech. Engineers, 1902—see also *The Engineer*, November 15th, 1895, and August 15th, 1902.

About 1888 metallic packing began to supersede the old hemp packings. It came over from America, where the "United States" metallic packing was in use on the Pennsylvania Railroad and other lines. The earliest use of metallic packing was embodied in Edward Cartwright's British specification of 1797. It may have been tried on locomotives in this country before 1888, but no record of it has been found.

Coupling-rods.—Coupling-rods of I section were introduced here in 1882 by T. W. Worsdell on the G.E.R. It is stated that Thomas Rogers first used them in the United States of America in 1854. In 1867 an American engine by the Grant Locomotive Works, and a German engine by Krauss, both with I rods, were shown at the Paris Exhibition, and during 1870-79 a large number of German locomotives were supplied with them.

Valve Gears.—Kitson's valve gear has already been mentioned. Two other forms of radial valve gear were tried in this country, one by Morton on the North British Railway and the other, already mentioned, by Bryce Douglas on the Caledonian Railway. The latter did not receive further application, but Jas. Holden fitted a 2-4-0 express engine on the G.E.R. (No. 644) with the Morton gear.

Sanding Apparatus.—In 1885 an air-sanding apparatus, the invention of F. Holt, works manager at Derby, was severely tested on the heavy gradients of the Settle and Carlisle section of the M.R., by removing the coupling-rods of a 2-4-0 express engine, converting it temporarily into a single engine. The sand-box was placed inside the smoke-box, and a jet of compressed air taken from the Westinghouse brake reservoir was employed to blow the sand under the treads of the driving wheels. The results were very successful, but the Westinghouse Company objected to the use of air taken from the reservoir, on the ground that the brake power was affected detrimentally. Steam was therefore substituted for air, and the present form of steam sanding apparatus came

into existence, and was taken up by Gresham and Craven. The use of it enabled single engines to be used for many years afterwards; without it, they would have disappeared before the end of last century.

Water Pick-up Apparatus.—In 1888 Sir John Aspinall, on the Lancashire and Yorkshire Railway, made two important improvements in Ramsbottom's water pick-up apparatus, hitherto in use only on the L. and N.W.R. tender engines, on which the scoop was lowered and lifted by hand. The first improvement consisted in attaching the bottom hinged portion of the scoop by means of a rod to a diaphragm piston which worked in a cylinder similar to that of the Hardy-Aspinall vacuum brake. Under the tender is a reservoir or vacuum chamber, and on the foot-plate a three-way cock. The three pipes from the latter are connected to the chamber and to the cylinder both above and below the diaphragm piston. By turning the cock in one direction air is admitted above the diaphragm, the space below the latter being placed in communication through the cock with the vacuum chamber, and the scoop is lowered. To raise it, the cock is turned in the opposite direction; air is admitted below the piston, and the space above it now communicates with the chamber. The lower hinged portion of the scoop has a balance weight which assists the lifting and keeps the scoop in the raised position. The apparatus could be worked by means of a steam or compressed air cylinder.

The second improvement was the application of the above apparatus to tank engines which run in both directions. There are two scoops facing in opposite directions, both coupled to one discharging pipe and also connected together by levers. The different arrangements are such that either one or both may be lowered into the trough at the same time. Usually both are lowered together, and with this system a hinged flap valve at the junction of the two scoops automatically closes the scoop facing backwards, so that the water taken up by the other cannot escape.

Cabs.—T. W. Worsdell on the N.E.R., from 1886 onwards, fitted all his engines with large covered-in American type cabs, with side windows. These cabs were very similar to those made by R. Stephenson and Co. in 1860 for two Stockton and Darlington engines. Since 1898 similar cabs have been used on the Great Eastern and Great North of Scotland railways, and more recently on the G.C.R. In 1884 James Manson on the Great North of Scotland Railway applied hinged side doors to the foot-plates of tank engines to protect the men from draughts when travelling bunker first. These engines were built by Kitson. S. W. Johnson on the Midland immediately copied this arrangement. Similar doors are now universally applied, not only to tank but also to tender engines.

TABLE IX.—Express Engines with Single Driving Wheels.

Railway.	Type.	Cylinders.	Dia. of driving wheels.	Dia. of carrying wheels.	Wheel base.	Boiler diameter.*	Heating surface.			Pressure.	Weight in working order.						
							Tubes.	Fire-box.			Grate area.	Leading or bogie.	Driving.		Trailing.		Total.
								sq. ft.	sq. ft.				sq. ft.	lb., sq. in.	t.	c.	
M.S. and L.R.	2-2-2	17½" x 26"	7' 6"	3' 8"	7' 9"+8'	3' 10"	1057	87	1144	17	11 3	17 11	11 18	10 12	t. c.		
G.N.R.	"	18½" x 26"	7' 7½"	4' 1½"	10' 8"+8' 5"	4' 1"	936	109	1045	18.4	12 4	17 8	11 1	40 13	"		
G.W.R.	"	18" x 26"	7' 8"	4' 6"	9' 6"+8' 6"	4' 2"	1120.3	130	1250.3	19.2	11 0	15 0	10 0	36 0	"		
G.W.R.	"	18" x 26"	7' 8"	4' 6"	9' 6"+8' 9"	4' 2"	1153.9	137.7	1291.6	18.3	12 0	16 10	12 10	41 0	"		
G.E.R.	"	18" x 24"	7'	4'	7' 9"+8' 9"	4' 3"	1124.9	105.5	1230.4	17.9	13 5½	16 2½	10 15½	40 3½	33 15½		
C.R.	4-2-2	18" x 26"	7'	3' 6"	6' 6"+6' 7"+8'	4' 3"	973	112	1085	17.4	13 10	17 0	11 8	41 18	37 19		
M.R.	"	18½" x 26"	7' 6"	4' 4"	6' 7'-0"+8' 9"	4' 1"	1123.6	117	1240.6	19.68	14 10	18 0	11 12	44 2	41 1		

* The dimensions given in this column represent the *mean inside* diameters of boilers, except in a few cases, of which published figures give no detailed particulars, and in some instances probably show maximum outside diameters.

TABLE X.—Express and Passenger Engines with Four-coupled Driving Wheels.

N.E.R.	2-4-0	18" x 24"	7' 1"	4' 6"	8'+8' 8"	4' 3"	221-1½"	1100.9	114	1214.9	17	12 12	15 14	13 16	42 2	39 14
G.E.R.	"	18" x 24"	7'	4'	7' 9"+8' 9"	4' 3"	236-1½"	1124.9	105.5	1230.4	17.9	14 8½	14 1	13 10½	42 0½	38 18½
G.W.R.	"	18" x 24"	6' 13"	4' 1"	9'+8' 6"	4' 2"	262-1½"	1352.7	116.1	1468.8	19	13 8	15 10	13 12	42 10	39 7
Do., 5' d gauge	"	20" x 24"	7'	4' 6"	9' 6"+9'	4' 3"	266-1½"	1484.3	123.4	1557.7	20.8	13 12	16 0	14 18	44 0	"
N.E.R.	4-4-0	17" x 24"	6' 7"	3'	5' 3"+6' 11½"+8' 4"	4' 2"	200-1½"	966.7	104.5	1071.2	16.9	11 8	14 2	12 0	37 10	34 12
M.R., 1667	"	19" x 24"	7'	3' 6"	6'+7'+8' 6"	4' 1"	205-1½"	1011.5	110.1	1121.6	17.5	14 16¼	15 0¼	12 18¼	42 16¼	39 11¼
M.R., 1740	"	18" x 26"	7'	3' 6"	6'+7'+8' 6"	4' 1"	246-1½"	1151	110.1	1261.1	17.5	14 12¼	15 0	13 2½	42 14¼	39 11
S.E.R.	"	19" x 26"	7'	3' 9"	5' 4'+7' 4"+8' 6"	4' 4"	202-1½"	917	103.5	1020.5	16.78	13 8	15 5	12 17	41 10	"
C.R.	"	18" x 26"	6' 6"	3' 6"	6' 6"+6' 7"+9'	4' 5½"	216-1½"	1095.6	113	1208.6	19	14 15	15 4	15 4	45 3	"
N.B.R., 592	"	18" x 24"	7'	3' 6"	6' 6"+6' 7"+9' 3"	4' 3"	206-1½"	983	119	1102	21	16 0	15 5	14 16	46 1	"
N.B.R., 633	"	18" x 26"	6' 6"	3' 6"	6' 6"+6' 7"+9' 6"	4' 4"	238-1½"	1148	118	1266	20	15 3	15 12	15 3	45 18	"
G. & S.W.R.	"	18½" x 26"	6' 9½"	3' 7½"	5' 9'+7' 3"+8' 6"	4' 2"	238-1½"	1092	106	1198	17.5	13 13	15 15	12 17	42 5	"
G.N. of S.R.	"	18" x 26"	6' 6½"	3' 6½"	5' 6'+7' 3"+8' 9"	4' 4"	—	1094	106	1200	18	13 2	14 10	14 8	42 0	38 16
L. & Y.R.	"	18" x 26"	6'	3' 0½"	5' 6'+7' 5½"+8' 11"	4' 2"	220-1½"	1121.3	107.7	1229	18.75	13 16	15 0	14 10	43 6	40 0
L.B. & S.C.R.	0-4-2	18½" x 26"	6' 6"	4' 6"	7' 7'+8'	4' 4"	331-1½"	1372.9	112.5	1485.4	20.65	13 16	14 10	10 8	38 14	"
L. & S.W.R.	"	18" x 26"	6' 1"	4'	8'+8' 10"	4' 4"	216-1½"	1121	110	1231	17	14 18	16 2	11 5	42 5	"

Chapter XX—1890 - 1900

HITHERTO the development of the British locomotive has been dealt with in considerable detail, but from 1890 onwards it is not proposed to devote so much space to the subject, since the more modern engines are better known to those interested, and many of the more notable classes have been frequently described and illustrated.

Two-cylinder Compound Engines.—After T. W. Worsdell's resignation, only one engine of this type was designed and built on the N.E.R.; by his brother, Wilson Worsdell, in 1893—Fig. 361. It was a 4-4-0 engine with 7ft. coupled wheels. The high-pressure cylinder, 20in. by 26in., and the low-pressure cylinder, 28in. by

that gear. In 1895 two 2-4-0 express engines were built by the same firm with 7ft. coupled wheels and 18in. and 26in. by 24in. cylinders, but were converted to 4-4-0 at Belfast in 1897.¹ In 1905 to 1908, after the Midland Railway had acquired the B. and N.C.R., under the new title of the Northern Counties Committee, a number of similar 4-4-0 compound engines with 6ft. coupled wheels and 18in. and 26in. by 24in. cylinders were built for the Irish line at Derby and Belfast works. There were also two 0-6-0 goods compound engines by Beyer, Peacock, 1892, with 5ft. 2in. wheels and 18in. and 26in. by 24in. cylinders. All the above had inside Walschaerts valve gear.

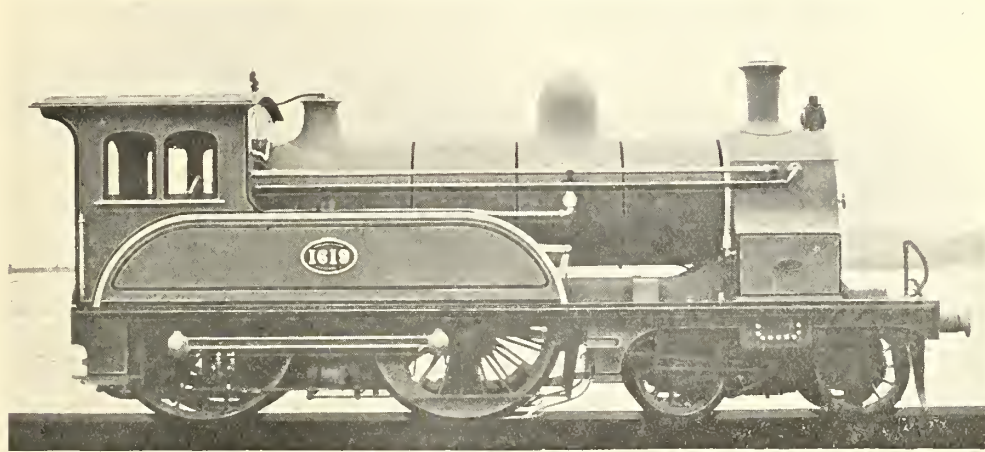

FIG. 361—W. WORSDELL'S TWO-CYLINDER COMPOUND EXPRESS ENGINE No. 1619, NORTH-EASTERN RLY., 1893

26in., with the steam chests outside. The pressure of 200 lb. was then the highest in this country. This engine was completely reconstructed in 1898 as a three-cylinder compound engine on W. M. Smith's system—Fig. 362.

Though the two-cylinder compound shortly afterwards began to disappear in Great Britain, it was adopted in 1890 by Mr. B. Malcolm on the Belfast and Northern Counties Railway, for which many engines of this type were built until 1908. There were also a few on the Belfast and County Down Railway. The designs were made by Beyer, Peacock, who built the first 2-4-0 engines in 1890, with 6ft. coupled wheels, high-pressure cylinder 16in. diameter, low-pressure cylinder 23½in. diameter by 24in. stroke, pressure 170 lb.—Fig. 363. These engines had v. Borries disc intercepting valves, and inside Walschaerts valve gear, and were the first in the British Isles, other than the tank engine on the Swindon, Marlborough and Andover Railway, to be fitted with

On the Great Southern and Western Railway, Ireland, H. A. Ivatt in 1894 converted a 4-4-0 simple engine into a two-cylinder compound with 18in. and 26in. by 24in. cylinders, but retained the original pressure of 150 lb.—Fig. 364. The driving wheels had a diameter of 6ft. 7in. Instead of the automatic starting and intercepting arrangement of Worsdell, a special "triplex" valve was used. It was non-automatic and allowed the driver to admit boiler steam into the low-pressure cylinders. This experimental engine was hardly successful; the triplex valve was liable to get out of order, and excess of steam in the low-pressure cylinder tended to choke the exhaust. The engine was reconverted to a simple engine with 18in. by 24in. cylinders in 1901.²

Compound Locomotives, Webb's Three-cylinder System.—Following the "Teutonic" class

¹ See THE ENGINEER, January 5th, 1900, and the LOCOMOTIVE MAGAZINE, March, 1899.

² See THE ENGINEER, May 24th, 1896, and the LOCOMOTIVE, August, 1917.

of 1889-1890, F. W. Webb, on the L. and N.W.R., introduced the eight-wheeled "Greater Britain" class, of which ten were built at Crewe between 1891 and 1894—Fig. 365. The second

driving axle. The excentric rods were somewhat short, and the long valve rods actuated the upper ends of rocking shafts, the lower ends of which transferred the movement to the valve spindles.



FIG. 362—W. WORSDELL'S EXPRESS ENGINE No. 1619, N.E. RLY., REBUILT AS A THREE-CYLINDER COMPOUND, 1893

of these engines, the "Queen Empress," was shown at the Chicago Exhibition of 1893. The starting power of the "Teutonics" with 14in. high-pressure cylinders left a good deal to be desired, and therefore the high-pressure cylinders of the new engines were increased to 15in. diameter. The low-pressure cylinders remained 30in. diameter and the stroke of both high-pressure and low-pressure 24in., as before. The driving wheels were 7ft. 1in. diameter, as in the "Teutonics," but it was decided that the new engines might be better with a small pair of carrying wheels, 4ft. 1½in. diameter, under the foot-plate. These wheels had ordinary axle-boxes with 1in. total side play, but the leading wheels had Webb's

The balanced slide valves worked in steam chests placed inside the frames as in the usual British design for outside cylinders. The low-pressure valve gear had the loose excentric with fixed cut-off as in the later "Teutonic" class.

The extremely long boiler was the main feature. The tubes were divided into two lengths by a so-called combustion chamber, 2ft. 10in. long, with a manhole and hopper at the bottom. The 156 tubes were 2½in. diameter outside, those between fire-box and combustion chamber being 5ft. 10in. long. The length of the front tubes was 10ft. 1in. The water bottom type of fire-box was discarded and a return made to the usual foundation ring. The hopper of the combustion chamber was fitted with



FIG. 363—B. MALCOLM'S TWO-CYLINDER COMPOUND ENGINE, BELFAST AND NORTHERN COUNTIES RLY., 1890

radial axle-boxes. The high-pressure valve gear was completely altered, and the former outside Joy's gear replaced by inside Stephenson's link motion, the excentrics being placed on the second

a weighted valve, which remained shut when not actuated by the driver from the foot-plate. There was also a steam tube-cleaning apparatus so arranged that steam blown into the combustion

chamber passed through both sets of tubes. The tube heating surface was 1346 square feet; combustion chamber, 39.1 square feet; fire-box, 120.6 square feet; total, 1505.7 square feet. Much of the tube heating surface at the front was of small value. The grate area was 20.5 square feet;

the afternoon Scotch dining car expresses. The combustion chambers were a source of trouble. Whether much combustion took place inside them, after most of the flame had been extinguished during its passage through the first set of tubes, is open to question.

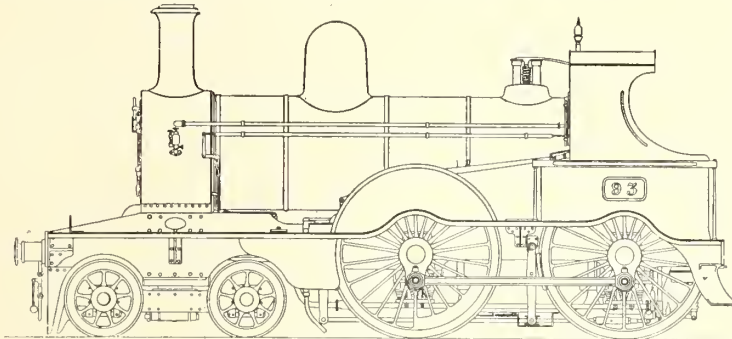

FIG. 364—H. A. IVATT'S COMPOUND EXPRESS ENGINE, GREAT SOUTHERN AND WESTERN RLY., 1894

pressure, 175 lb.; wheel base, 8ft. 5in. + 8ft. 3in. + 7ft. = 23ft. 8in. Incidentally it may be added that these ten engines, together with the succeeding ten engines of the "John Hick" class, were the only British express tender engines which had two driving axles placed between single leading and trailing carrying axles. The weight in working order was 52 tons 2 cwt., of which each pair of driving wheels carried 15½ tons. The leading wheels carried 12 tons 16 cwt. and the trailing wheels 8 tons 6 cwt.

Following these, ten similar engines, the "John Hick" class, were built, 1894-98, with 6ft. 3in. driving wheels, for the Crewe-Carlisle road. They were the worst of all Webb's three-cylinder engines, and had not been very long on main line trains before they had to be taken off, after which

In 1893 Webb introduced 0-8-0 mineral engines on the three-cylinder compound system, though his first 0-8-0 engine in 1892 was a two-cylinder simple engine.³ From 1893 to 1900, 111 compound engines of the new type were built.⁴ The outside high-pressure cylinders, 15in. by 24in., and the single inside low-pressure cylinder, 30in. by 24in., were in line under the smoke-box and all drove the second axle. All the wheels, 4ft. 5½in. diameter, were coupled, the total wheel base being 17ft. 3in., equally divided. In this design Webb abandoned one of the chief advantages of his three-cylinder passenger engines, viz., the drive divided between two axles. The three connecting-rods were only 5ft. 8in. long, and the ratio of rod to crank length 5.67 to 1. All three cylinders were somewhat steeply inclined at 1 in 8½, and

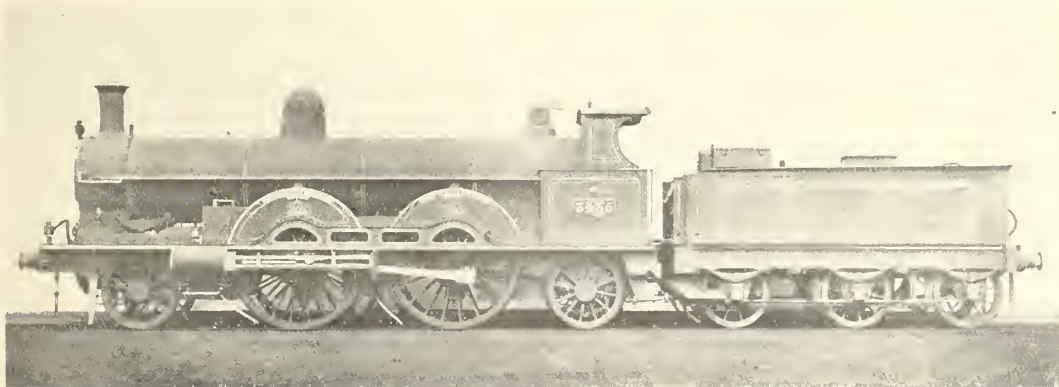

FIG. 365—F. W. WEBB'S THREE-CYLINDER COMPOUND ENGINE, "GREATER BRITAIN" CLASS, L. & N.W. RLY., 1891

they were used for a few years on secondary trains and were then scrapped. The "Greater Britain" class with the larger wheels were much better, though by no means so good as the "Teutonic," and not infrequently required a pilot engine on

this arrangement tended to aggravate the pitching movement.

The boiler, unlike that of the passenger engines,

³ See THE ENGINEER, December 11th, 1908.

⁴ See the LOCOMOTIVE MAGAZINE, February, 1897.

had no combustion chamber, the barrel being 15ft. 6in. long with the smoke-box tube-plate set back within it, so that the 210 $1\frac{1}{4}$ in. tubes had a length between tube-plates of 13ft. 4in. Their heating surface was 1374.3 square feet and the total heating surface 1489 square feet; grate area, 20 $\frac{1}{2}$ square feet; pressure, 175 lb. The outside high-pressure cylinders had the steam chests inside the frames with vertical unbalanced valves driven by Stephenson's link motion. The inside low-pressure cylinder had its valve on the top driven by a loose eccentric and rocking shaft, and all five eccentrics were fixed on the second or driving axle. The coupling-rods were in three lengths, the back length between the intermediate and trailing wheels being placed outside the other two. The leading and trailing axles had $\frac{1}{2}$ in. side play. Weight in working order: leading, 12 tons 10 cwt.; driving, 14 tons 8 cwt.; intermediate, 12 tons 14 cwt.; trailing, 9 tons 13 cwt.; total, 49 tons 5 cwt. Since 1904 all these engines have been gradually converted to simple engines with two inside cylinders, some 18 $\frac{1}{2}$ in. by 24in. and others more recently enlarged to 20 $\frac{1}{2}$ in. by 24in. with larger boilers. There are now no three-cylinder compound engines on Webb's system in existence in this country.

Four-cylinder Compound Engines: Webb's System.—In 1897 Webb built two 4-4-0 engines at Crewe works, of which the second one, "Black Prince," was a compound engine with all four cylinders in line under the smoke-box, the other being a non-compound engine to be mentioned subsequently. The outside high-pressure cylinders were 15in. by 24in., and the inside low-pressure cylinders 19 $\frac{1}{2}$ in. by 24in. The cylinder ratio, which in Webb's later three-cylinder compounds was 2 to 1, was now reduced to 1.69, a figure much less than that generally considered desirable in practice. The low-pressure cylinders were found to be too small, and were subsequently enlarged to 20 $\frac{1}{2}$ in. diameter, a size adopted for all other four-cylinder compounds of Webb's design. The cylinder ratio now became 1.87. The valve gear was Joy's, operated from the inside connecting-rods only, and one set of motion drove both high-pressure and low-pressure valves on each side of the engine. The inside low-pressure valve spindle was carried through the steam chest, and attached to a horizontal rocking lever in front, the other end of which actuated the outside high-pressure valve spindle. The points of cut-off in both cylinders were therefore interdependent. Piston valves were used for the high-pressure cylinders and balanced slide valves for the low-pressure cylinders. The boiler was of similar dimensions to that of the "Dreadnought" and "Teutonic" classes, with 1401 square feet of nominal heating surface, and the fire-box with water bottom reappeared, thereby including about 40 square feet of false heating surface. The pressure in the first engine of 1897 was 175 lb., but in subsequent engines was raised to 200 lb.

The coupled wheels were 7ft. 1in., and the truck wheels 3ft. 9in. diameter; wheel base, 6ft. 3in. + 7ft. 3in. + 9ft. 8in.; weight in working order, bogie 18 tons 18 cwt., driving 18 tons, trailing 17 tons 10 cwt., total 54 tons 8 cwt.; the first engine weighed $\frac{1}{2}$ ton less. The inside and outside cranks on the same side were at 180 deg., so that the reciprocating masses practically balanced each other. The outside revolving masses were balanced in the large wheel bosses which were cored out, and there were no balance weights in the rims. The inside revolving masses were balanced by extensions of the crank web slabs, the crank axle being of the built-up pattern. The inside crank pins were hollow, 7 $\frac{1}{4}$ in. diameter, with a 2-in. hole drilled through them. The coupling-rods, 9ft. 8in. in length, were then the longest in use. The leading end was carried on a four-wheeled radial truck. A double chimney was fitted to the first engine, but was afterwards discarded.

Forty engines similar to the above were built down to the end of 1900—Fig. 366—but the subsequent forty from 1901 to 1903, known as the "Alfred the Great" class, were of enlarged dimensions. As originally built, the high-pressure cylinders were 16in. by 24in., the low-pressure cylinders remaining 20 $\frac{1}{2}$ in. by 24in.; this again reduced the ratio to 1.64. The boiler was enlarged from 4ft. 2 $\frac{1}{4}$ in. to 4ft. 6 $\frac{3}{4}$ in. mean outside diameter, and the tube heating surface increased to 1328.5 square feet, and the nominal fire-box surface to 179 $\frac{1}{2}$ square feet, including the water bottom; pressure, 200 lb.; the total weight was 57 tons 12 cwt., of which the driving and trailing wheels were loaded with 19 and 18 tons respectively.

In this case, again, the cylinder ratio had to be increased, and the high-pressure cylinders reduced to 15in. diameter, making the ratio 1.87. Moreover, G. Whale, who succeeded Webb, rightly decided that the interdependent cut-off in both high-pressure and low-pressure cylinders was not an economical arrangement, and fitted all forty engines of the "Alfred the Great" class with additional outside Joy valve gear, so that the point of cut-off could be varied at will in the high and low-pressure cylinders. There was only one reversing screw, which actuated both high and low-pressure reversing shafts, either together or independently. This arrangement was described and illustrated in *The Engineer*, January 8th, 1904, and indicator diagrams were given showing the effect of the alteration. The forty engines of the "Black Prince" class, with the smaller boilers, remained unaltered. Ultimately, from 1908 to the present time, nearly all the eighty four-cylinder compounds, except a few which have been broken up, have been rebuilt as simple 4-4-0 engines with 18 $\frac{1}{2}$ in. by 24in. inside cylinders.

In 1901 H. A. Hoy, on the Lancashire and Yorkshire Railway, compounded a 4-4-0 express engine on somewhat similar lines to Webb's four-

cylinder engines. The outside high-pressure cylinders were 12 $\frac{3}{8}$ in. by 24in., and the inside low-pressure cylinders 21 $\frac{1}{2}$ in. by 26in. The cylinder volume ratio, neglecting clearance, was 3.18, the highest ever used in this country. The valves were actuated by inside Joy's gear and rocking levers, as in Webb's design. The engine having been reconstructed from one of the standard engines, a standard boiler having 1216.4 square feet of heating surface, and 18 $\frac{3}{4}$ square feet grate area was used, but the pressure was raised to 200 lb. The driving wheels were 7ft. 3in. diameter, and the total weight in working order 48.1 tons, of which 33.6 tons were available for adhesion. In 1908 it was again reconstructed by Mr. G. Hughes as a simple engine with super-heater.

Three-cylinder Compound Engine: Beyer, Peacock and Co.—In 1891-92 Beyer, Peacock built

system, which has since been so successfully developed during the present century on the Midland Railway, will be mentioned more fully later on. The fire-box of the North-Eastern engine was provided with three sets of cross water tubes, 1 $\frac{3}{4}$ in. diameter, seven in each set. This engine, which is still at work, has coupled wheels 7ft. 1 $\frac{1}{4}$ in., and bogie wheels 3ft. 7 $\frac{1}{4}$ in. diameter; wheel base, 6ft. 6in. + 7ft. 9in. + 9ft. 3in.; the boiler, 4ft. 6in. outside diameter, contained 234 1 $\frac{1}{4}$ in. tubes; heating surface, tubes 1171.3 square feet, fire-box 118.6 square feet, water tubes 34.1 square feet, total 1324 square feet; grate area, 23 square feet; pressure, 200 lb.; weight in working order, 53 tons, of which 35 $\frac{1}{2}$ tons are carried on the coupled wheels.

Triple-expansion Locomotive.—In 1895 F. W. Webb again altered the first experimental two-cylinder compound engine of 1878 to a triple-

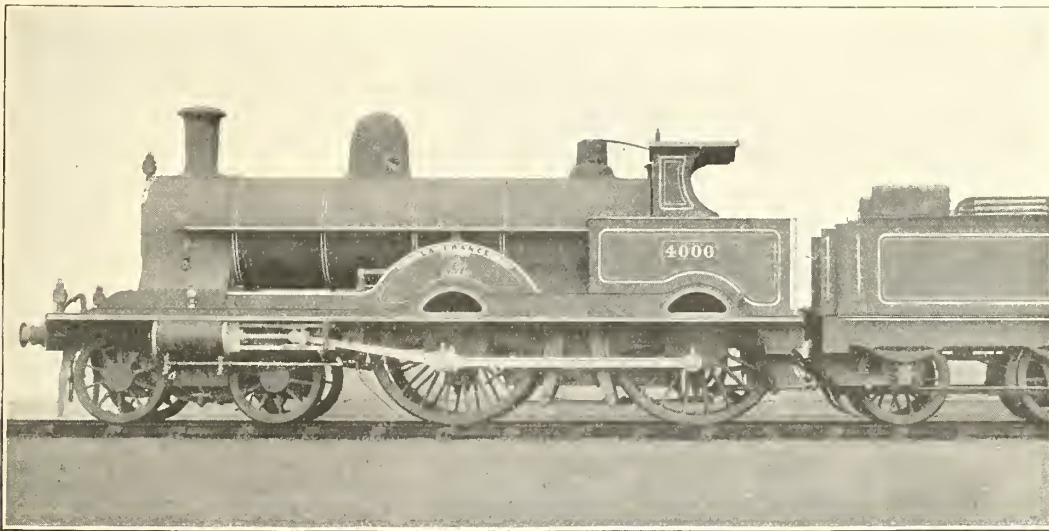

FIG. 366—F. W. WEBB'S FOUR-CYLINDER COMPOUND EXPRESS ENGINE "BLACK PRINCE" CLASS, 1897-1900

for New South Wales fifty 4-6-0 passenger engines, of which two were experimental compounds of a type never used in this country. All three cylinders were 20in. diameter and placed outside. The two on the low-pressure side were superimposed somewhat after the manner of Vaucrain compounds, but both received steam simultaneously from the single high-pressure cylinder on the opposite side. The arrangement was equivalent to a two-cylinder compound, in which the low-pressure cylinder was divided.

Three-cylinder Compound Engines: W. M. Smith's System.—In 1898 the two-cylinder compound 4-4-0 engine, No. 1619, of the N.E.R.—Fig. 361—was completely reconstructed as a three-cylinder compound engine to W. M. Smith's design, with one inside high-pressure cylinder, 19in. by 26in., and two outside low-pressure cylinders, 20in. by 24in. Ratio of cylinder volumes, neglecting clearances, 1.91. Smith's

expansion engine. The original locomotive, as previously mentioned, was a 2-2-2 outside cylinder 6ft. single engine of the "Allan" type. In its latest condition the engine, re-named "Triplex," had the high-pressure cylinder 9 $\frac{1}{4}$ in. diameter on the right side, an intermediate-pressure cylinder 13in. diameter on the left side, and an inside low-pressure cylinder 19 $\frac{1}{2}$ in. diameter. The stroke was 20in., as in the original engine. Stephenson's link motion was retained for the outside cylinders, and the gear for the inside cylinder was a loose excentric similar to that used in the later three-cylinder compounds. The intermediate cylinder was provided with a by-pass valve for admitting boiler steam. The pressure was 200 lb. For some reason, possibly to make room for pipe connections, the front tube-plate was recessed well back inside the barrel, so that the tubes were comparatively short. The engine had great difficulty in starting even with one coach behind the

tender, probably owing to the exhaust from the intermediate cylinder getting into the low-pressure steam chest before the loose excentric had reversed the low-pressure engine. The engine was tried occasionally with Mr. Webb's saloon coach, but did comparatively little work even with it, and was broken up in 1903.

replaced D. Gooch's 8ft. single engines. On September 16th, 1892, one of the new engines left the rails when descending the 1 in 100 gradient in Box Tunnel. The cause of the accident appears to have been excessive lateral play, over $1\frac{1}{2}$ in., of the leading axle-boxes in their guides, uncontrolled by springs. The result was that all of

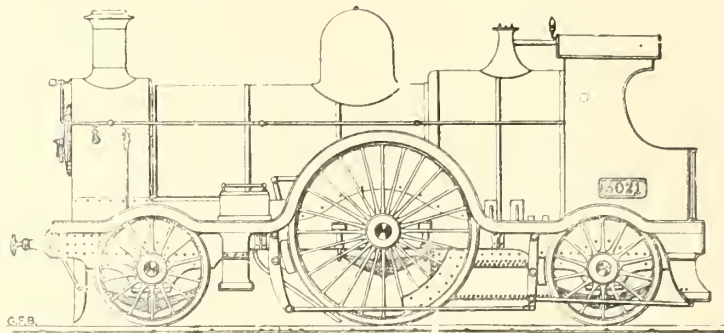

FIG. 367—W. DEAN'S BROAD GAUGE CONVERTIBLE EXPRESS ENGINE. "3001" CLASS, GREAT WESTERN RLY., 1891

TWO-CYLINDER HIGH-PRESSURE ENGINES.

2-2-2 Locomotives.—Engines of this type were built by the Great Western Railway at Swindon in 1891-92, with double frames for all axles, and by the Great Northern Railway in 1892-94 at Doncaster with inside driving bearings. G.N.R. No. 981 of 1894 was the last 2-2-2 engine ever built, and by the end of 1914 none of the type remained on any railways as main line trains had then become too heavy for single wheelers.

The G.W.R. engines, "3001" class, which are illustrated by Fig. 367, presented several interesting features. The cylinders, 20in. by 24in., had slide valves beneath, driven directly by Stephenson's link motion. The driving wheels were 7ft. 8½in., and the carrying wheels 4ft. 7in. diameter. The springs of all axles were underhung. Wheel base, 9ft. 6in. + 9ft. To obtain more steam space a return was made to the old form of raised fire-box casing, and the majority of Great Western boilers, from 1891 to the end of the century, were of that type; but, unlike most earlier engines with barrels of smaller diameter, the top only of the casing was raised. In the "3001" class the fire-box roof stays were a combination of sling and girder stays. Twelve short bridges were bolted to the crown, and were connected to the casing by twelve vertical slings. Drawings of this boiler appeared in *The Engineer* of October 21st, 1892. The total heating surface was 1445 square feet, of which the fire-box, which had a water pocket in the roof, provided 123.9 square feet; grate area, 20.8 square feet; pressure, 160 lb.; weight in working order: leading 13 tons 4 cwt., driving 19 tons, trailing 12 tons, total 44 tons 4 cwt. Eight of these engines were built as broad gauge convertible engines, with the wheels outside the frames. When the broad gauge disappeared in May, 1892, thirty engines of the type

these engines were converted to the 4-2-2 type with leading bogies, as described on the next page.

4-2-2 Locomotives.—A very large number of engines with single driving wheels and leading bogies were built from 1890 to 1901. Dimensions are given in Table XI. The G.N.R. engines numbered (1) of 1894-95 were the only ones with outside cylinders; they were P. Stirling's 8ft. singles, in which the cylinders were enlarged from 18in. by 28in. to 19½in. by 28in. (one engine 19in. by 28in.), but in spite of this the heating surface was reduced to 1032 square feet only, though the fire-box and grate area were larger. They are illustrated by Fig. 368. The driving wheels carried 19.2 tons, according to the official record, though Mr. Rous-Marten told the writer that more than 20 tons rested upon them. Of these, No. 1006 was derailed at St. Neots in 1895, and No. 1007 at Little Bytham in 1896, and although a brittle

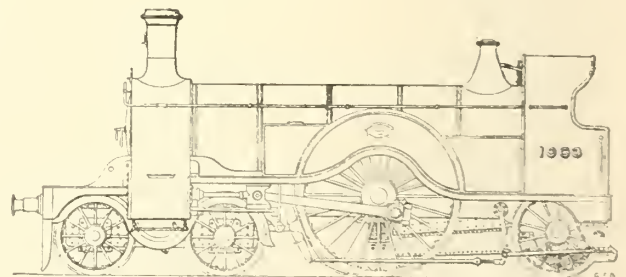

FIG. 368—P. STIRLING'S SGL. SINGLE EXPRESS ENGINE. GREAT NORTHERN RLY., 1894.

rail was the primary cause in one case, it was considered that excessive weight on the driving wheels contributed to one if not both accidents. This weight was afterwards reduced to about 18 tons. These engines did good work, though

whether they were better than their predecessors with smaller cylinders is doubtful. The latter, however, had been enlarged in most cases to 18½ in.

The engines numbered (2 to 8) in the Table had inside cylinders, and those of the G.W.R., M.R., and G.E.R. (Fig. 369) (2 to 5) had double frames

—with piston valves above the cylinders, direct driven by Stephenson's link motion, and the trailing axle was modified to have outside bearings—Fig. 371. The G.N.R. engines—Fig. 372—by H. A. Ivatt, 1900-1, also had inside bearings for the driving and bogie axles, and balanced slide

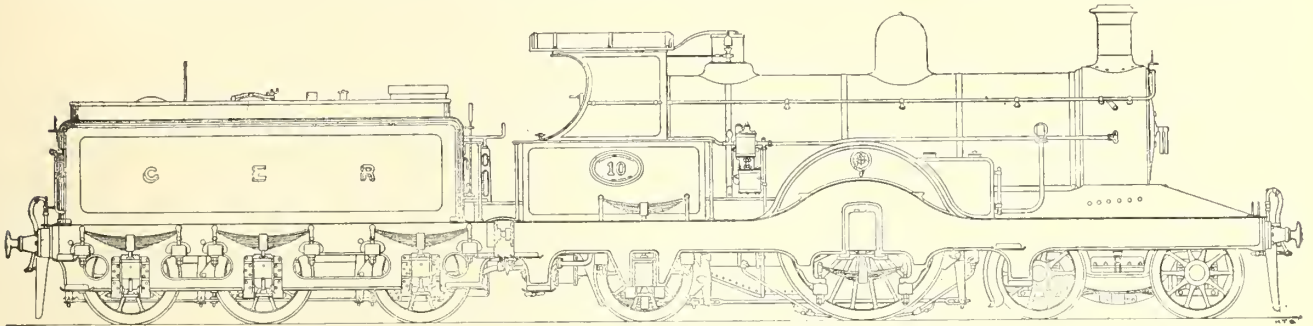

FIG. 369—J. HOLDEN'S EXPRESS ENGINE, GREAT EASTERN RLY., 1898

and four bearings for the driving axle. The G.W.R. engines, "3031" class, also had an outside framed bogie—Fig. 370. This class was derived from the large 2-2-2 engines of 1891-92, which were themselves modified by the addition of bogies, and the trailing springs were placed above the platforms instead of being underhung. The cylinders were reduced from 20 in. to 19 in. diameter. In all, there were 80 of the class, the last of which were built in 1899, but all have now been broken up.

The Midland engines were somewhat similar to Fig. 330 *ante*, but had spiral springs for the driving axle, and piston valves below the cylinders, driven by direct motion. One of the "2601" class (4) was shown at the Paris Exhibition of 1900. The Great Eastern engines of 1898 (5) were

valves above the cylinders driven by rocking shafts and Stephenson's link motion. The exhaust steam passed directly to the blast pipe through the back of the valves. Only the G.C.R. engines (8) had inside bearings for all axles; they were designed by H. Pollitt and had piston valves underneath, as in the Midland engines. The fire-boxes were of the Belpaire type—Fig. 373.

The G.N.R. engines of 1901 were the last engines to be built for a British railway with single driving wheels, and all were broken up in 1918 owing to the greatly increased weight of trains. Of single engines still in service at the end of 1925 there were only 30 left, 27 of which were on the Midland section of the L.M. & S.R.

2-4-0 Engines.—Between the end of 1889 and 1895, 90 2-4-0 engines, with inside cylinders and

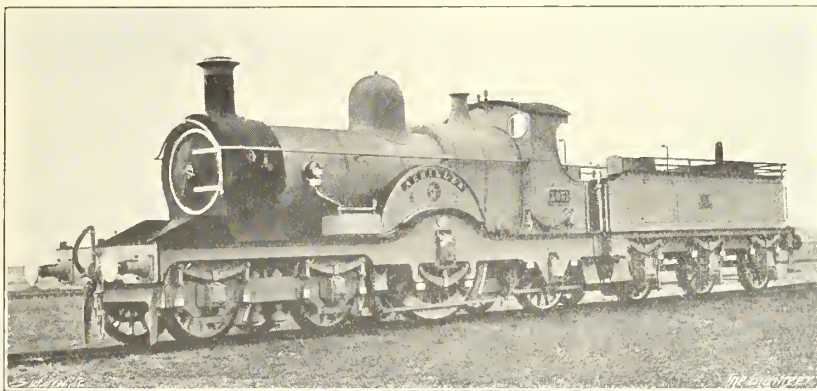

FIG. 370—W. DEAN'S GREAT WESTERN RLY. EXPRESS, "3031" CLASS, 1894-99

the only engines with driving wheels smaller than 7ft. 6in. They had Trick slide valves below the cylinders, and were fitted with J. Holden's oil-fuel apparatus.

The N.E.R. engines (6) were reconstructed in 1894 from the compound engines—Fig. 318 *ante*

frames, and Allan's link motion, were built by F. W. Webb at Crewe. The new engines were similar to the "Precedents," but had smaller, 6ft. 3in., wheels and 150 lb. pressure. They replaced the 5ft. 6in. "Precursors" on the Preston-Carlisle and the Manchester-Leeds sec-

tions. The cylinders were 17in. by 24in., and the total weight 33.2 tons, of which 22.85 tons were carried on the coupled wheels.

J. Holden on the G.E.R. built 100 2-4-0 engines at Stratford, 1891-1902, for the long branch lines of that railway—Fig. 374. They have 5ft. 8in. coupled wheels, and 17½in. by 24in. cylinders, inclined at 1 in 8. The slide valves are below and placed horizontally. The leading axle has both inside and outside bearings. The outside axle-boxes have 1in. play in the horn cheeks, but the inside boxes fit their guides, the axle bearings being without collars. Total heating surface, 1208.3 square feet; grate, 18 square feet; pressure, 140 lb. in the first 80 and 160 lb. in the last 20 engines. Weight in working order, 40.3 tons,

period. All these, except those numbered (9, 10, 23, 24, 25 and 26) are of the standard British type with inside cylinders and frames. The L. and S.W.R. engines (9 and 10), and the Highland engines (26) have outside cylinders, and the G.W.R. engines (23 to 25) inside cylinders and double frames. Only the following salient features need be noted.

The L. and S.W.R. engines numbered (9) and (10) by W. Adams had bogies, the wheel base of which, 7ft. 6in., was the longest in the country. They were also the most powerful express engines then (1890-92) running. The class with 6ft. 7in. wheels is illustrated by Fig. 375.

The Lancashire and Yorkshire express engines (11)—Fig. 376—by Sir John A. F. Aspinall, built



FIG. 371.—T. W. WORSDELL'S SINGLE EXPRESS ENGINE, NORTH-EASTERN RLY., AS REBUILT IN 1894

of which the leading axle carried 14.125 tons.

P. Stirling on the G.N.R. continued the construction of 2-4-0 engines for general traffic until his death in 1895, and H. A. Ivatt built ten very similar engines in 1897, also with 17½in. by 26in. cylinders and 6ft. 7½in. coupled wheels, but with larger domed boilers carrying 170 lb. pressure. The heating surface was 1123.8 square feet, of which 103.1 square feet were provided by the fire-box. Nearly all the G.N.R. 2-4-0 engines have been broken up during recent years and at the end of 1925 only two remained.

The last 2-4-0 engine built for a British railway was constructed in 1903 by Beyer, Peacock & Co. for the Stratford and Midland Junction Railway.

4-4-0 Engines.—Table XI gives the leading dimensions of the principal classes of the 1890-1900

at Horwich 1891-94, were remarkable in having the largest coupled wheels, 7ft. 3in. diameter, used up to that time, in spite of the extremely severe gradients of the railway. An awkward locomotive problem had to be solved to meet the conditions on the new line between Manchester and Liverpool *via* Atherton which had recently been opened. The expresses ran through to Liverpool from Yorkshire, and the speeds over the heavily graded section between Bradford and Manchester were such that the older 6ft. coupled engines sufficed. To run the trains through between Manchester and Liverpool at speeds of 52 to 54 miles per hour, start to stop, necessitated a change of engines at the former place, and the new engines were built to overcome the difficulty. Sir John Aspinall also had in mind that the steam consumption per in-

licated horse-power of the large wheeled engines at high speeds was less than that of the engines with the smaller 6ft. wheels. In the matter of hill climbing, the writer, who was a very frequent

cylinders, and the "60" class (13) piston valves. The earlier engines of the latter class had 19½ in. by 26 in. cylinders, as shown in the table, but in the later "2636" class the diameter was reduced

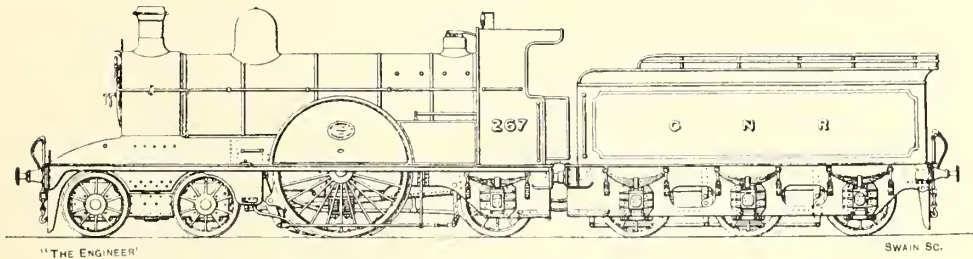

FIG. 372—H. A. IVATT'S EXPRESS ENGINE, GREAT NORTHERN RLY., 1900-1901

traveller between Manchester and Yorkshire, noticed that the 7ft. 3in. coupled engines reached the summit at Walkden, 18 miles from Manchester, in quite as good time, with a load of six 8-wheeled bogie carriages, and showed to much greater

to 19 in. The latter were much the better engines, and did excellent work. A large number of Midland engines, similar to (12) with 18½ in. by 26 in. cylinders, had 6ft. 6in. wheels. The writer's experience in timing trains over different sections

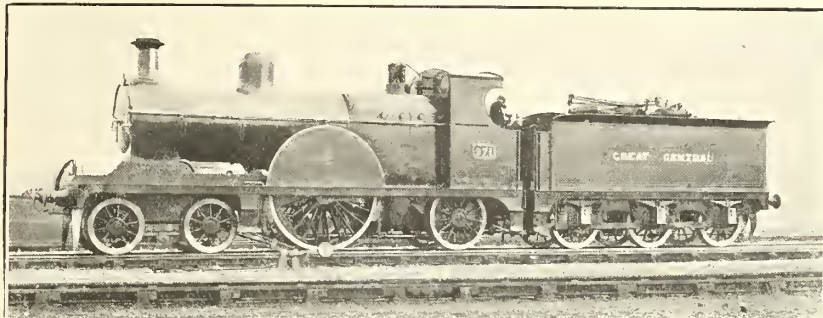

FIG. 373—H. POLLITT'S EXPRESS ENGINE, GREAT CENTRAL RLY., 1900

advantage over the remaining portions of the road. These are the only two-cylinder engines in the table which had Joy's valve gear. Some of the early engines of 1891 originally had 19 in. cylinders, but those with 18 in. cylinders proved

showed that the 7ft. engines were in nearly all cases the better. During recent years many of the 6ft. 6in. engines have been renewed with 7ft. wheels.

The three North-Eastern engines (14), (15),

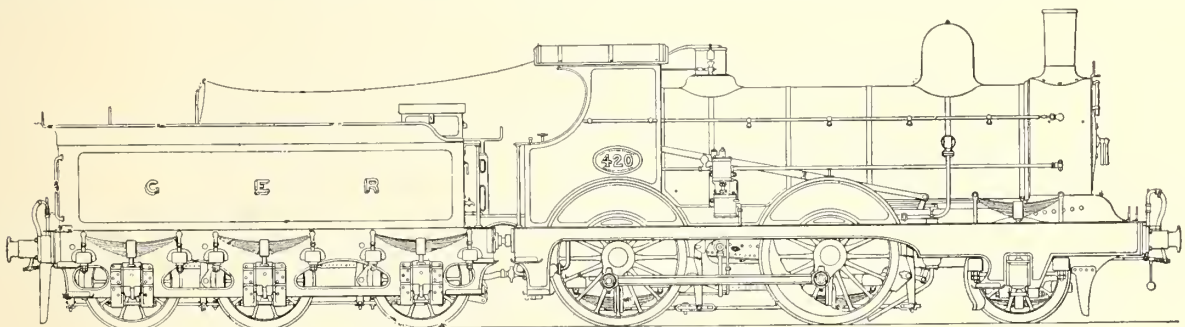

FIG. 374—J. HOLDEN'S MIXED TRAFFIC ENGINE, GREAT EASTERN RLY., 1891-1902

to be better, and that size became standard for the class.

Of the Midland engines by S. W. Johnson, the "2183" class (12) had slide valves between the

and (16) represent different designs by Wilson Worsdell. The "1620" class (14), of 1892-93, had outside steam chests and rocking shafts, and was illustrated in *The Engineer*, October 27th,

1893. The last engine of the twenty had piston valves—see drawings in *The Engineer*, September 20th, 1895. The outside steam chests, being exposed to the cold air, were not satisfactory, and some years later the engines were altered to have inside piston valves and direct motion.

class,⁵ came out in 1899, and sixty were built before the end of 1907. They have direct driven piston valves. A pressure of 200 lb. was used. These engines have given excellent results.

The Glasgow and South-Western engines (17), by J. Manson, built at Kilmarnock, 1892-1904,

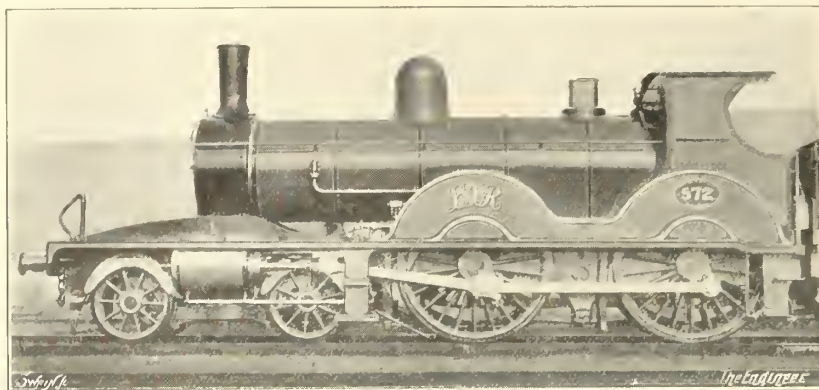

FIG. 375—W. ADAMS'S EXPRESS LOCOMOTIVE, L. & S.W.R., 1892-93

Of the thirty-two engines (15) of 1896-97 only two had 20in. by 26in. cylinders and coupled wheels 7ft. 7½in. diameter, the largest ever used in this country. They are illustrated by Fig. 377, and were specially built in case the 1895 race of the Scotch trains was to be resumed in 1896. The other engines were similar, but had 19½in. by 26in. cylinders, 7ft. 1in. coupled wheels, and coupled wheel base 3in. shorter. The slide valves were above the cylinders and driven through rocking shafts. More recently they have been provided with direct-driven piston valves. Although the cylinders were larger, the boilers were con-

had indirect rocking shaft motion similar to that designed by the same engineer on the Great North of Scotland Railway. Domed boilers were also introduced.

J. F. McIntosh's Caledonian engines, "Dunalastair" class (18) of 1896,⁶ and the succeeding "766" class (19) of 1897 were the first engines in which boilers of the large diameter of 4ft. 8in. were used. They were modern examples of Sturrock's dictum that "the power of a locomotive was measured by its capacity to boil water." The Great Western 4-2-2 engines (2) had more heating surface, being fitted with a larger number of tubes packed into a smaller barrel. The later

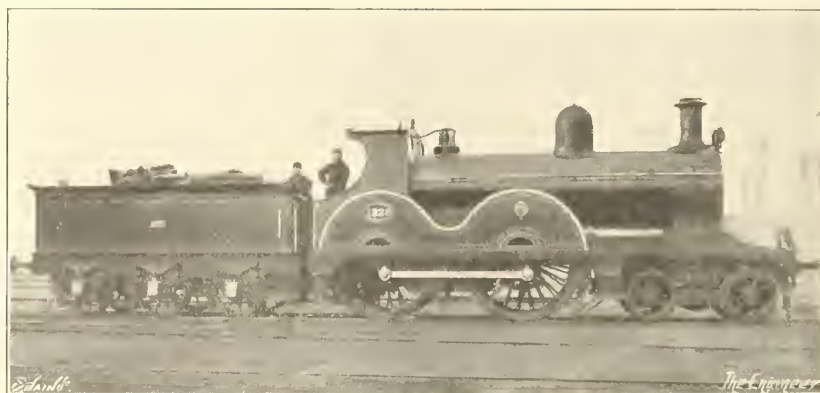

FIG. 376—SIR J. A. F. ASPINALL'S EXPRESS ENGINE, LANCASHIRE & YORKSHIRE RLY., 1891-94

siderably smaller than those of the "1620" class. The reason is unknown to the writer. The "1620" class also had extended smoke-boxes, but those of the "1871" class (15) were of the then usual short pattern.

The engines numbered (16), known as the "R"

"766" class, the first of which for a time carried the name "Dunalastair 2nd," is shown by Fig. 378.

⁵ See the *LOCOMOTIVE MAGAZINE*, January, 1900.

⁶ See *THE ENGINEER*, March 6th, 1896, and the *LOCOMOTIVE MAGAZINE*, March, 1896.

The boiler of the latter was longer. The eight-wheeled double-bogie tenders were a feature of the "766" class. Their capacity was 4125 gallons of water and 7 tons of coal. Both classes had

work over the heavy gradients west of Newton Abbot. Both bogie and tender wheels had solid wood centres of Mansell's carriage wheel type. The fire-box casings were flush with the barrel,



FIG. 377—W. WORSDELL'S EXPRESS ENGINE WITH 7ft. 7 $\frac{1}{2}$ in. WHEELS, NORTH-EASTERN RLY., 1896

slide valves between the cylinders, driven by Stephenson's link motion.

The L. and S.W.R. engine (21), by D. Drummond, 1899, had fire-box water tubes. The coupling-rods were of the great length of 10ft., exceeding by 4in. Webb's rods of 1897, but the length of Drummond's outside cranks was only 9in.

The G.W.R. engines (23), (24) and (25), by W. Dean, had double plate frames and differed

and the fire-box roof was stayed at the front by "half-girders," the rear ends of which at the middle of the box were supported by slings attached to the casing. The back half of the fire-box was supported by sling stays only. Part of the exhaust steam was returned to the tender for feed heating, and crosshead-driven feed pumps were used. The Ramsbottom type of double-beat regulator, which had been used for about twelve years on the G.W.R., gave place to

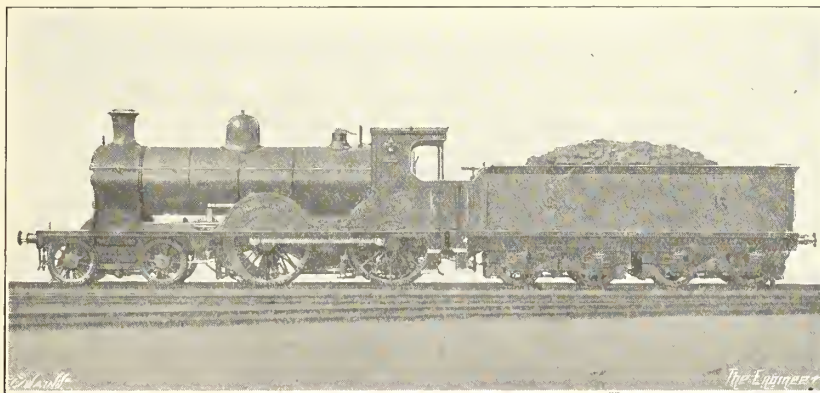

FIG. 378—J. F. McINTOSH'S "766" CLASS EXPRESS ENGINE, CALEDONIAN RLY., 1897

completely from the types on other railways. The engines (23) of 1895-97,⁷ were designed to

⁷ See THE ENGINEER, October 8th, 1897, and the LOCOMOTIVE MAGAZINE, February, 1896.

the gridiron sliding type. A special feature was an extended smoke-box, 5ft. 0 $\frac{3}{4}$ in. long, with wire netting spark arrester.

Type (24) of 1894, which was illustrated in

The Engineer of November 2nd, 1894, consisted of four engines only, which were remarkable for their 20in. by 26in. cylinders. They were the only coupled engines on the G.W.R. standard gauge to have wheels as large as 7ft. diameter.

the Midland engines (12 and 13) were by Sharp, Stewart and Neilson, engines (21 and 26) were by Dübs, and most of (22) by Sharp, Stewart.⁸ Engines (20, 22 and 26) which have not been specially mentioned above, were designed by

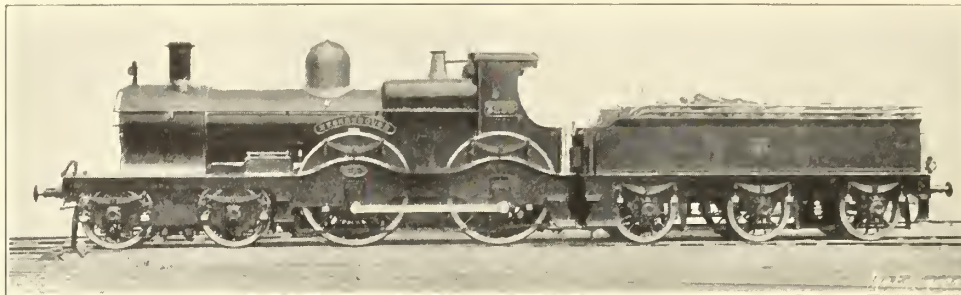

FIG. 379—W. DEAN'S EXPRESS ENGINE, GREAT WESTERN RLY., 1897-99

The boilers had round-topped raised fire-box casings. These engines were over-cylindrical and never appeared capable of the good work done by the following engines (25), with 18in. by 26in. cylinders. The latter—Fig. 379—were built in 1897-99 and had long extended smoke-boxes, as in engines (23). The fire-boxes were of the Bel-paire type raised above the boiler barrel, and one of the class, No. 3310 "Waterford," had a larger domeless boiler—Fig. 380. The bogies and tenders had spoked wheels, and the Mansell wood

H. A. Ivatt, R. J. Billinton, and D. Jones respectively. The list is far from complete, but space does not permit further additions.

Four-cylinder Non-compound Engines.—The first four-cylinder engine, other than those of the articulated type, was built by Haswell, of Vienna, and shown at the London Exhibition of 1862. The two outside cylinders on each side were inclined so that their axes met at the centre of the driving axle. This design has been found in the records of R. Stephenson and Co.⁹ It



FIG. 380—W. DEAN'S EXPRESS ENGINE "WATERFORD," No. 3310, 1899
(Photo. Locomotive)

wheels of class (23) were not repeated after 1897. All three engines (23, 24 and 25) had slide valves below the cylinders driven by Stephenson's motion with quadrant links suspended from the top.

The majority of the engines in the table were built at the companies' own works, but some of

⁸ See *THE ENGINEER*, June 7th and 14th, 1901, and the *LOCOMOTIVE MAGAZINE*, March, 1900.

⁹ Letter to R. Stephenson & Co. from J. D. Wardale, Sept. 8th, 1913, and original drawing in their possession, dated October, 1846, and exclusive of the Stockton and Darlington engine by Wilson, see page 3.

seems that Hall, the inventor of the Hall crank, may have taken the design to the Continent, where it was actually tried. In 1897 James Manson, on the Glasgow and South-Western Railway, and F. W. Webb, on the London and North-Western Railway, independently and almost simultaneously put into service two 4-4-0 engines with four high-pressure cylinders in line under the smoke-box. The outside and inside cylinders drove the same axle, the cranks on the same side being at 180 deg. Manson's engine, illustrated by Fig. 381, had outside cylinders 12½ in. by 24 in. and inside cylinders 14½ in. by 26 in., the combined volume of the two being practically equivalent to the volume of the standard 18½ in. by 26 in. cylinder of engine 17 in Table XI. The inside cylinders had a common

compound engine. His new engine, No. 28 in the table, had two inside cylinders, 15 in. by 24 in., which replaced the two low-pressure cylinders, 19½ in. by 24 in. In other respects, it was exactly similar to the compound engine already described (Fig. 366), but the boiler was hardly large enough to supply four 15 in. high-pressure cylinders, and the engine was subsequently altered to a compound.

D. Drummond's L. and S.W.R. engine 720—No. 29 in the Table—also built in 1897, had two pairs of uncoupled driving wheels, the front pair driven by inside, and the rear pair by outside cylinders, the latter placed behind the bogie. All four cylinders were originally 16½ in. by 26 in., but were too large, and shortly afterwards had to be reduced to 15 in. diameter. The inside valve gear

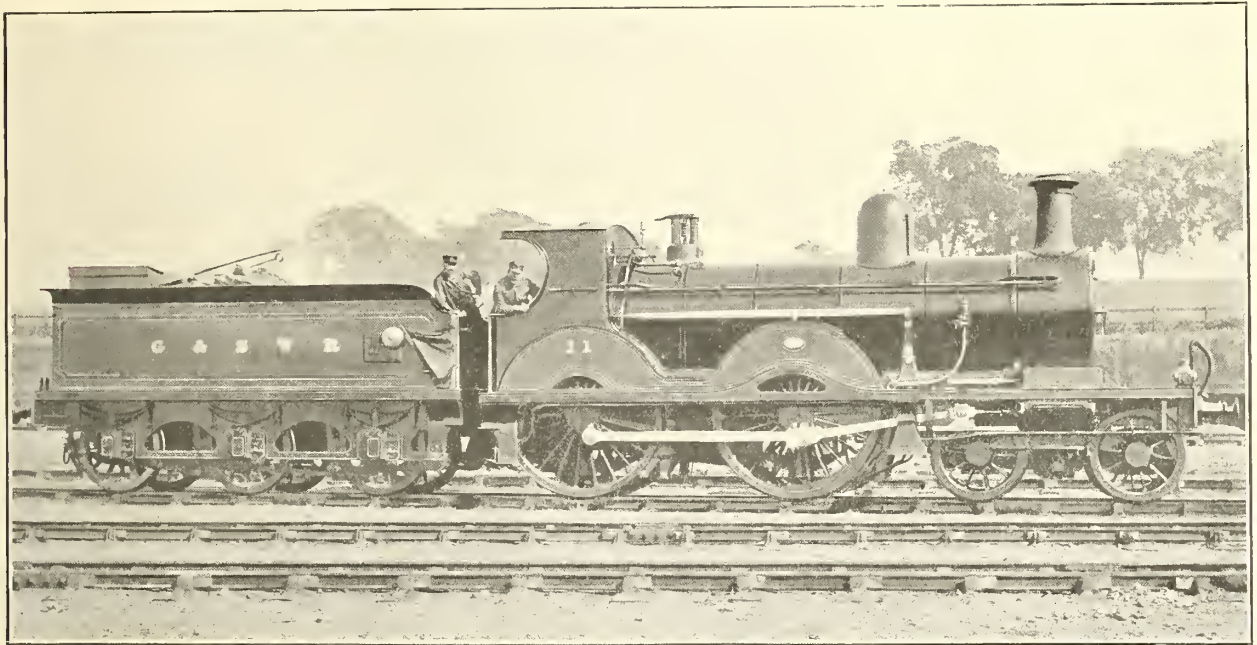

[Photo. Locomotive

FIG. 381—J. MANSON'S 4-CYLINDER ENGINE, GLASGOW & SOUTH-WESTERN RLY., 1897

steam chest between them, with valves driven directly by Stephenson's motion. The outside cylinders had valves on the top driven through rocking shafts from the inside gear. The general dimensions are given in Table XI (No. 27). Only one engine was built, and it was completely reconstructed in 1923 by Mr. R. H. Whitelegg with outside cylinders 14 in. by 24 in. and inside cylinders 14 in. by 26 in., and one piston valve for the outside and inside cylinders on each side, this arrangement necessitating cross ports. The new boiler with superheater is much larger and carries 180 lb. pressure. Further particulars are given later.

Whilst Manson's main object was to produce a better balanced engine, Webb, though attaining the same end, had also in view a comparison between a four-cylinder simple and a four-cylinder

was Stephenson's, and the outside Joy's, the latter similar to that used on Webb's three-cylinder compound engines. The engine is illustrated by Fig. 382, but a large boiler was fitted in 1905. The type, of which five more were built in 1901, was never copied on any other railway. Although it had the advantages of dividing the power between two axles, and of allowing room for a very long fire-box, it had the disadvantage of irregular turning moment, and also of irregular balancing effects, owing to the absence of coupling-rods. The dimensions after the 1905 rebuilding are also given in the table, reference 29a.

4-4-2 *Express Engines*.—In 1898 H. A. Ivatt, on the Great Northern Railway, introduced the first "Atlantic" engines—Fig. 383—into this country. It was what may be termed a true "Atlantic" in that the outside cylinders drove the second pair

TABLE No. XI.—Express Locomotives, Period 1890 to 1899.

Ref. No.	Railway and class.	Type.	Cylinders.	Diameter of wheels.		Boiler dia.*	Tubes.	Heating surface.		Grate area, sq. ft.	Weight in working order.					
				Driving	Carrying			Tubes, sq. ft.	Fire-box, sq. ft.		Total, sq. ft.	Boiler, t. c.	Driving, t. c.	Trailing, t. c.	Total, t. c.	
1	G.N.R., 1003	4-2-2	19½" x 28" (outs.)	8' 1½"	3' 11½"	4' 0"	174 1½"	910	121.7	1031.7	20	170	19 12	19 4	10 15	49 11
2	G.W.R., 3031	"	19" x 24"	7' 8½"	4' 1½"	4' 2½"	206 1½"	1434.3	127	1561.3	20.8	160	18 0	18 0	13 0	49 0
3	M.R., 115	"	19½" x 26"	7' 9"	3' 9½"	4' 1"	236 1½"	1105	128	1233	21.3	170	15 16½	18 10	12 15½	47 24
4	M.R., 2601	"	"	7' 9½"	3' 10"	4' 1½"	228 1½"	1070	137	1217	21.5	180	16 16½	18 10	14 10½	50 3
5	G.E.R., 10	"	18" x 20"	7' 0"	3' 9½"	4' 3"	227 1½"	1178.5	114.2	1292.7	21.3	160	15 6	19 0	14 14	49 0
6	N.E.R., 1517	"	19" x 24"	7' 7½"	3' 7½"	4' 3"	203 1½"	1016	123	1139	20.7	175	—	—	—	46 19
7	G.N.R., 267	"	19" x 26"	7' 8"	3' 8"	4' 3½"	215 1½"	1143.8	125.8	1269.6	23.2	175	—	—	—	48 11
8	G.C.R., 967	"	19½" x 26"	7' 9"	3' 6"	4' 3"	200 1½"	1062	132	1194	24.8	200	16 6	18 7	12 12	47 5
9	L. & S.W.R., 577.	4-4-0	19" x 26" (outs.)	7' 1"	3' 9½"	4' 4"	240 1½"	1245.6	122.1	1367.7	18	175	18 7½	15 9	14 17	48 13½
10	L. & S.W.R., 557.	"	19" x 26" (outs.)	6' 7"	3' 7"	4' 4"	230 1½"	1193.7	126.4	1320.1	19.75	175	18 0½	15 14½	14 16	48 11
11	L. & Y.R., 1102...	"	18" x 26"	7' 3"	3' 0½"	4' 2"	220 1½"	1108.7	107.7	1216.4	18.75	160	13 16	16 10	14 10	44 16
12	M.R., 2183	"	18½" x 26"	7' 0"	3' 6"	4' 1½"	244 1½"	1106	117	1223	19.6	160	14 8	16 15	13 2½	44 5½
13	M.R., 60 and 2636	"	19½" x 26"	7' 0"	3' 6"	4' 1½"	236 1½"	1105	128	1233	21.3	170	15 1½	16 10½	13 13	45 14½
14	N.E.R., 1620	"	19" x 26"	7' 1"	3' 7"	4' 4"	225 1½"	1220	121	1341	19.6	160	17 0	18 4	15 10	50 14
15	N.E.R., 1869	"	20" x 26"	7' 7½"	3' 7½"	4' 4"	201 1½"	1089	127	1216	20.75	175	16 8	18 14	15 14	50 16
16	N.E.R., 2011	"	19" x 26"	6' 10"	4' 0"	4' 9"	255 1½"	1383	144	1527	20	200	16 9	19 13	15 12	51 14
17	G. & S.W.R., 8	"	18½" x 26"	6' 9½"	3' 7½"	4' 2"	238 1½"	1094	111	1205	18	150	14 4	16 10	14 7	45 1
18	C.R., 721	"	18½" x 26"	6' 6"	3' 6"	4' 8½"	265 1½"	1284.4	118.8	1403.2	20.6	160	15 14½	16 0	15 5	46 19½
19	C.R., 766	"	19" x 26"	6' 6"	3' 6"	4' 8½"	265 1½"	1381.2	118.7	1500	20.6	175	17 15	17 9½	17 2½	52 16½
20	G.N.R., 1321	"	17½" x 24"	6' 7½"	3' 7½"	4' 8"	238 1½"	1129.9	119.9	1249.8	20.8	170	16 10	17 0	14 0	47 10
21	L. & S.W.R., 702.	"	18½" x 24"	6' 7"	3' 7"	4' 5½"	280 1½"	1187	148	1500	24	175	15 0	—	35 8	50 8
22	L.B. & S.C.R., 52.	"	19" x 26"	6' 9"	3' 6"	4' 8½"	317 1½"	1509	126	1635	24	180	16 0	17 0	16 0	49 0
23	G.W.R., 3252	"	18" x 26"	5' 7½"	3' 7½"	4' 2"	249 1½"	1258.6	112.6	1398.2	19	160	17 10	15 7	13 3	46 0
24	G.W.R., 7	"	20" x 26"	7' 0"	4' 0"	4' 2½"	266 1½"	1434.3	127	1561.3	20.8	160	19 6	15 18	15 12	50 16
25	G.W.R., 3292	"	18" x 26"	6' 8"	4' 0"	4' 4"	112 2½" (Serve)	830½	121.3	951.3	18.3	180	19 6	17 1	15 6	52 3
26	H.R., 119	"	19" x 24" (outs.)	6' 3"	3' 3"	4' 4½"	244 1½"	1176	119	1295	20.5	175	17 12	15 10	14 9	47 11

Engines with Four High-pressure Cylinders.

27	G. & S.W.R., 11.	4-4-0	12½" x 24"	6' 9½"	3' 7½"	4' 2"	238 1½"	1062	111	1173	18	165	17 0	16 10	15 4	48 14
28	L. & N.W.R., 1501.	"	14½" x 26"	7' 1"	3' 9"	4' 1½"	225 1½"	1244.3	159.1½	1400.4	20.5	175	—	—	—	—
29	L. & S.W.R., 720.	1-2-2-0	15" x 26"	6' 7"	3' 7"	4' 5½"	271 1½"	1307	142	1664	27.4	160	16 17	18 18	18 16	54 11
29a	L. & S.W.R., 720.	"	15" x 26"	6' 7"	3' 7"	5' 0"	—	1392	173	1760	27.4	175	17 12	15 10	14 9	—

* Boiler diameter outside smallest ring. † Heating surface of Serve tubes on water side. ‡ Water tubes in fire-box. § Includes water bottom of fire box.

of coupled wheels, as in the original American design. The connecting-rods were 10ft. long; the cylinders were 18 $\frac{3}{4}$ in. by 24in.; driving wheels, 6ft. 7 $\frac{1}{2}$ in.; bogie wheels, 3ft. 7 $\frac{1}{2}$ in., and trailing

26.75 square feet; pressure, 175 lb.; weight in working order, bogie 15 tons, front coupled wheels 15 tons, driving wheels 16 tons, trailing wheels 12 tons, total 58 tons. These engines were

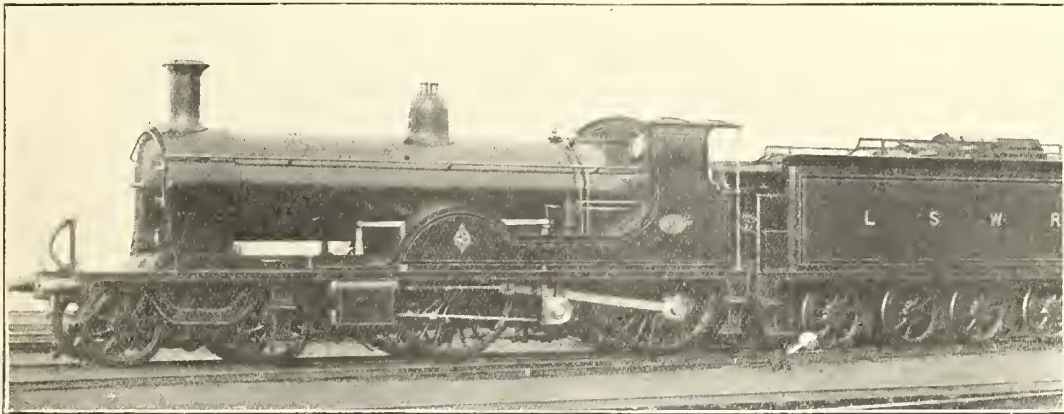

(Photo. Locomotive

FIG. 382—D. DRUMMOND'S FOUR-CYLINDER ENGINE, LONDON AND SOUTH-WESTERN RLY., 1897

wheels, which had outside bearings and lateral play, 3ft. 7 $\frac{1}{2}$ in. diameter; wheel base, 6ft. 3in. + 5ft. 3in. + 6ft. 10in. + 8ft. = 26ft. 4in. The bogie pins in Ivatt's engines were placed 1 $\frac{1}{2}$ in. behind the bogie centre line, similarly to those of P. Stirling's 8ft. singles. The boiler barrel,

the forerunners of the later "Atlantics" with much larger boilers.

Sir John Aspinall's large 4-4-2 engines, of which forty were built for the L. and Y.R. at Horwich in 1899-1902, are shown by Fig. 384. The cylinders, 19in. by 26in., are inside, with balanced

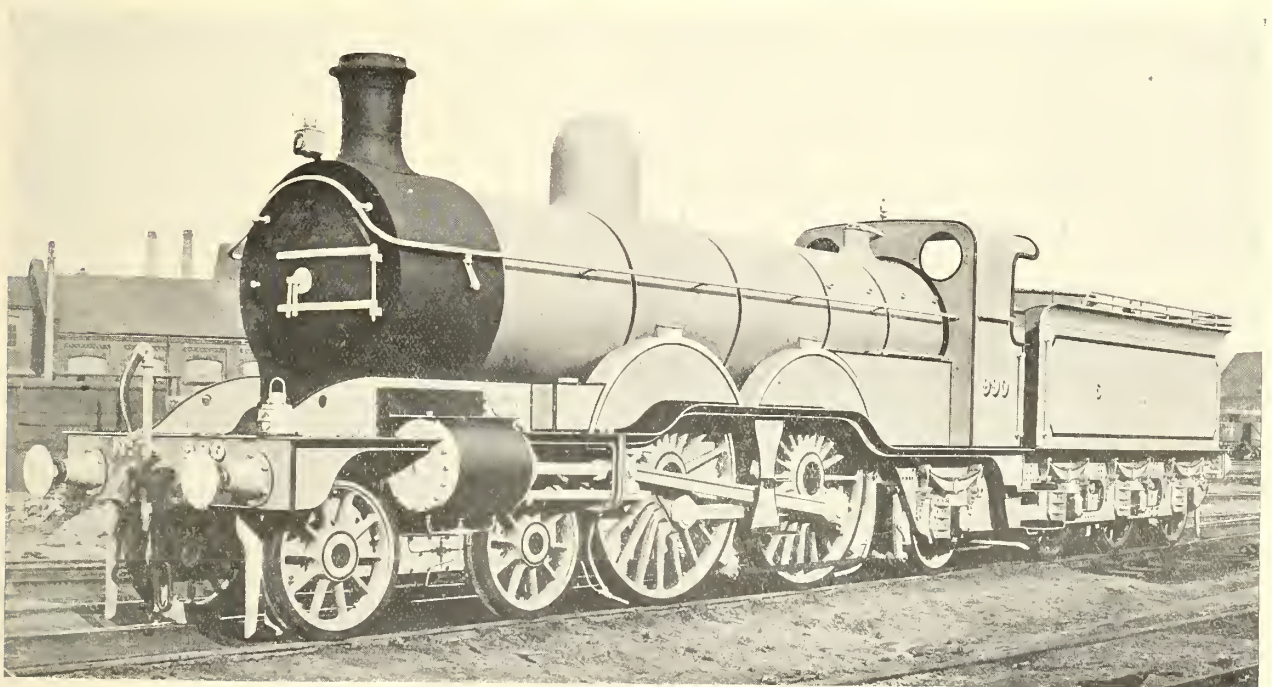

FIG. 383—H. A. IVATT'S "ATLANTIC" TYPE EXPRESS ENGINE, GREAT NORTHERN RLY., 1898

14ft. 8 $\frac{5}{8}$ in. long, was recessed back at the smoke-box end, so that the tube length was 13ft. The 191 2in. tubes provided 1302 square feet of heating surface; total, 1442 square feet; grate,

slide valves above, driven by Joy's gear, and exhaust through the back of the valve. The cylinders of the first twenty were steam jacketed. The trailing wheels had inside bearings, with

spiral springs on each side of the axle-boxes, connected by a yoke above. About ten years ago Mr. G. Hughes modified the trailing axle to have outside bearings. The coupled wheels are 7ft. 3in., bogie wheels 3ft. 0 $\frac{3}{4}$ in., and trailing

Australia, where, however, the regular speeds were considerably less. It is doubtful whether the type would have been a success here, had it been built at an earlier date, and its appearance coincided generally with that of harder tires and heavier

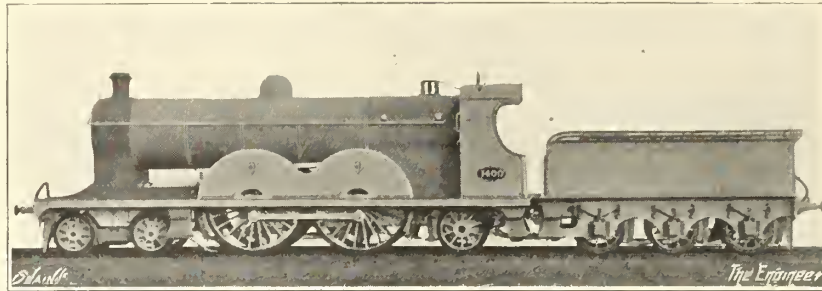

FIG. 384—SIR J. A. F. ASPINALL'S EXPRESS ENGINE, LANCASHIRE & YORKSHIRE RLY., 1899

wheels 3ft. 7 $\frac{1}{2}$ in. diameter; wheel base, 5ft. 6in. + 7ft. 5 $\frac{1}{2}$ in. + 7ft. 6in. + 7ft. 3 $\frac{1}{2}$ in. = 27ft. 9in. The boiler barrel, 4ft. 9in. diameter inside the front ring, was recessed similarly to Ivatt's engine; this reduced the tube length to 15ft.; the 239 2in. tubes provided 1877 square feet of heating surface, and the direct stayed Belpaire fire-box, 175.8 square feet; total, 2052.8 square feet; grate area, 26 square feet; pressure, 175 lb., subsequently increased to 180 lb. This boiler, the centre of which was 8ft. 11in. above rails, was then the largest in the country. Weight in working order, bogie 12.25 tons, coupled 35 tons, trailing 11.5 tons, total 58.75 tons. Originally the bogies were of the swing link type, but subsequently were altered to the Adams sliding type. For working drawing, see *The Engineer*, March 17th, 1899.

4-6-0 *Express Engines*.—Following D. Jones's

rails. A few years earlier the unequal tire wear of six-coupled wheels would have been detrimental to the success of such engines. The coupled wheels of Worsdell's new engines were only 6ft. 1 $\frac{1}{4}$ in. diameter. For a time these engines were employed on the East Coast expresses, and in 1900-1 five similar engines with larger 6ft. 8in. wheels were built. Finally, those with 6ft. wheels were relegated to heavy excursion and fast main line goods trains, for which the type became standard on the N.E.R., but for the fastest express work, the 4-6-0 type has been superseded on that railway by the 4-4-2 type.

Worsdell's engines had 20in. by 26in. cylinders; wheel base, 6ft. 6in. + 5ft. 6 $\frac{1}{2}$ in. + 7ft. + 7ft. = 26ft. 0 $\frac{1}{2}$ in.; the driving wheels were originally flangeless, but flanged tires were shortly afterwards provided; the boiler, 4ft. 9in. diameter, carried 200 lb. pressure, and had a total

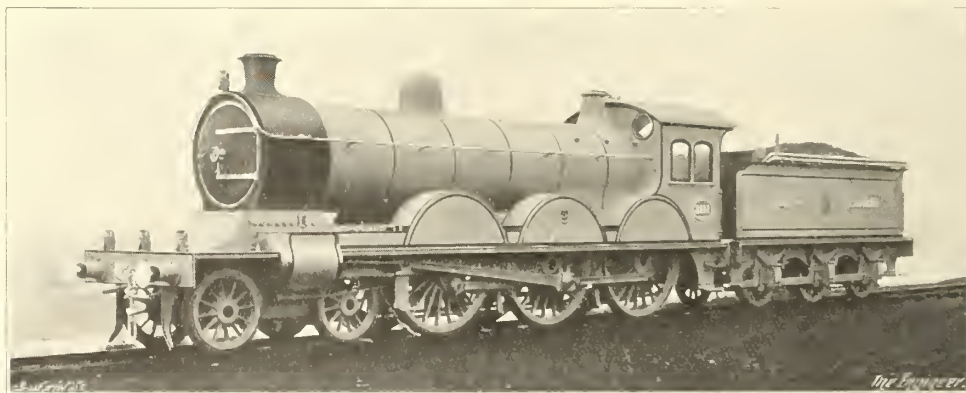

FIG. 385—W. WORSDELL'S 4-6-0 EXPRESS ENGINE. "2111" CLASS, NORTH-EASTERN RLY., 1900-1

4-6-0 goods engines of 1894 for the Highland Railway, Wilson Worsdell, of the N.E.R., in 1899-1900 built the first ten 4-6-0 express engines to be employed in this country, although the type had long been in use in America, Canada and

heating surface of 1768 square feet, of which the fire-box provided 130 square feet; grate, 23 square feet. To reduce corrosion, the smoke-box tube-plate was of copper. All engines, except the first three, had Smith's piston valves. The "2001"

(S) class weighed 66 tons in working order, of which $49\frac{1}{2}$ tons were available for adhesion.¹⁰ The "2111" class, with 6ft. 8in. wheels, weighed 67 tons 2 cwt., of which the driving wheels alone carried $19\frac{1}{2}$ tons, and the bogie 15 tons 3 cwt. The latter class is illustrated by Fig. 385.

7ft. 6in.; bogie base at both ends, 5ft. 6in.; heating surface, 1021 square feet; pressure, 160 lb.; weight in working order, leading bogie 13 tons 13 cwt., driving 15 tons $2\frac{3}{4}$ cwt., coupled 15 tons $5\frac{1}{4}$ cwt., trailing bogie 15 tons $15\frac{1}{4}$ cwt., total 59 tons $16\frac{1}{4}$ cwt. The bogies were not

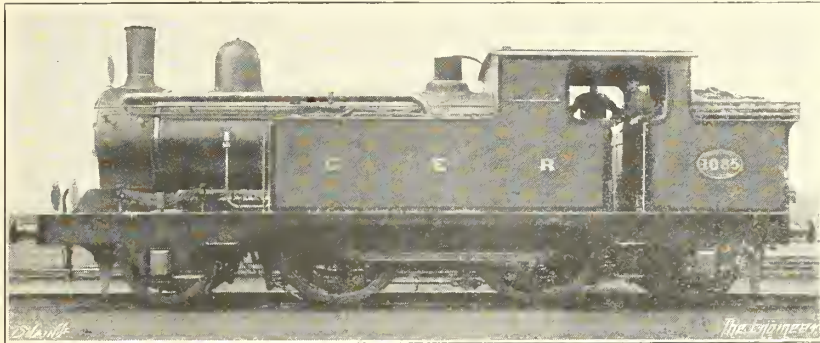

FIG. 386—J. HOLDEN'S 2-4-2 TANK ENGINE, GREAT EASTERN RLY., 1893-1902
[Photo. Locomotive Magazine]

Passenger Tank Engines.—A new type of 2-4-2 tank engine by James Holden, for long-distance local traffic, was built at Stratford, 1893-1902, for the G.E.R.—Fig. 386. Instead of radial axle-boxes, the leading and trailing wheels had both inside and outside bearings, the outside axle-boxes having a total lateral play of $1\frac{1}{2}$ in. The cylinders were $17\frac{1}{2}$ in. by 24in., with slide valves below; coupled wheels, 5ft. 8in.; carrying wheels, 4ft.; wheel base, 7ft. 6in. + 8ft. 9in. + 7ft.; total heating surface, 1217 square feet; pressure, 140 lb., in later engines 160 lb.; weight in working order, 58.6 tons, of which the coupled wheels carried 29.27 tons.

The 4-4-4 tank engine was first designed and three built by Beyer, Peacock and Co. in 1896 for the Wirral Railway. These engines are illus-

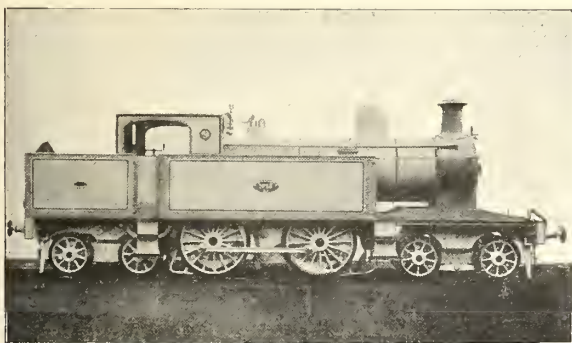

FIG. 387—BEYER, PEACOCK & CO.'S 4-4-4 TANK ENGINE, WIRRAL RLY., 1896

trated by Fig. 387. The inside cylinders were 17in. by 24in.; coupled wheels, 5ft. 2in. diameter; total wheel base, 30ft. 2in.; coupled base,

arranged symmetrically with respect to the centre of the coupled wheel base, the trailing bogie centre being nearer.

In 1897 Sharp, Stewart's designed and built two 4-4-4 tank engines for the Midland and South-Western Junction Railway. They had 17in. by 24in. cylinders; coupled wheels, 5ft. 3in. diameter; coupled wheel base, 7ft. 6in.; total wheel base, 31ft. $7\frac{1}{2}$ in.; tank capacity, 1900 gallons; weight in working order, $59\frac{1}{4}$ tons.

These five were the only 4-4-4 tank engines in this country until Sir Vincent Raven's large three-cylinder tank engines came out in 1913. S. W. Johnson prepared a design for the Midland Railway about 1898-99, but the engines were not built. A considerable number were made by Beyer, Peacock and other firms for the Buenos Aires Western Railway. They had outside cylinders.

Of 4-4-2 tank engines there was the enlarged London, Tilbury and Southend type with outside cylinders, 18in. by 26in., 6ft. 6in. coupled wheels and 170 lb. pressure, designed by T. Whitelegg.¹¹ These, built by Sharp, Stewart and Dübs, were express tank engines, and carried 1500 gallons of water and 45 cwt. of coal. Weight in working order 63.15 tons, of which 35.15 tons were available for adhesion. In 1907-9 a still further enlargement was made with 19in. by 26in. cylinders. The latter are now the standard engines of the L.M.S. Railway (Tilbury section), and a number have recently been built at Derby.

H. A. Ivatt from 1898 to 1907 adopted the 4-4-2 type with inside cylinders, $17\frac{1}{2}$ in. by 26in., for the local traffic of the G.N.R. His engines have 5ft. $7\frac{1}{2}$ in. coupled wheels and 170 lb. pressure. The leading bogie is of the swing link type and the trailing radial axle-boxes are similar to those

¹⁰ See THE ENGINEER, March 9th, 1900, and the LOCOMOTIVE MAGAZINE, September, 1899.

¹¹ See THE ENGINEER, December 17th, 1897, and the LOCOMOTIVE MAGAZINE, July, 1897

of the Bottomley design, previously described.

In 1897 F. W. Webb, on the L. and N.W.R., following W. Barton Wright's example of 1879 on the L. and Y.R., designed 0-6-2 tank engines for passenger traffic with 18in. by 24in. cylinders

slightly later cut-off of about $2\frac{1}{2}$ per cent. was attained in the low-pressure cylinder in both fore and back gear by making the lap of the low-pressure valve $\frac{1}{2}$ in. shorter. The total heating surface was 1162 $\frac{1}{2}$ square feet; pressure, 175 lb.;



FIG. 388—BEYER, PEACOCK & CO.'S COMPOUND TANK ENGINE, BELFAST & COUNTY DOWN RLY., 1891

and 5ft. 2 $\frac{1}{2}$ in. coupled wheels.¹² This design was simply that of the main line 0-6-0 goods engine of 1880, with the addition of side tanks and radial trailing axle. Piston valves replaced the slide valves of the goods engines.

Two-cylinder Compound Passenger Tank Engines.—The only compound passenger tank engines in the British Isles, other than Webb's four three-cylinder engines, were in Ireland. Four designed by Beyer, Peacock and Co. in 1891 for the Belfast and County Down Railway (Fig. 388) had inside cylinders, high-pressure 18 $\frac{1}{2}$ in., low-pressure 26in. diameter by 24in. stroke; driving wheels 5ft., and radial wheels 4ft. diameter; wheel base, 8ft. 5in. + 8ft. 9in.

weight in working order, 53 tons 19 $\frac{1}{4}$ cwt., of which 28 tons 4 $\frac{1}{2}$ cwt. rested on the coupled wheels. These engines were later converted to non-compounds and the leading axle replaced with a bogie. In 1892 the same makers built two two-cylinder compound tank engines, also of the 2-4-2 type but with outside cylinders, for the narrow gauge section of the B. and N.C.R., driving wheels 3ft. 9in.; cylinders, h.p. 14 $\frac{3}{4}$ in., l.p. 21in. by 20in. stroke. One of these is shown by Fig. 388A. Four similar engines were also built at Belfast by the N.C.C. between 1908 and 1920.

2-6-0 Goods Engines.—The last of the G.E.R. "Moguls" had been scrapped in 1887; from



[Photo. Locomotive

FIG. 388A—TWO-CYLINDER COMPOUND TANK ENGINE, BELFAST & NORTHERN COUNTIES RLY. (NARROW GAUGE), 1892

+ 7ft. 3in. The von Borries type of intercepting valve was used and the engines had inside Walschaerts valve gear, which was duplicate for both high-pressure and low-pressure sides, but a

¹² See THE ENGINEER, May 19th, 1899, and the LOCOMOTIVE MAGAZINE, November, 1898.

then until 1895 the 2-6-0 type did not exist on any British railway. But in 1895-97 the Midland and South-Western Junction Railway bought two engines from Beyer, Peacock of a design very similar to a large number built by that firm for New South Wales, with outside horizontal cylin-

ders, 18in. by 26in., 4ft. coupled wheels, rigid wheel base 11ft., and total wheel base 19ft. The pony truck had 2ft. 9in. wheels and carried 6.7 tons. Total weight, 43.15 tons. The pistons were provided with tail rods.

The only other 2-6-0 engines until the end of

175 lb.; weight in working order, 56 tons, of which 42 tons were available for adhesion. An illustration of one of these engines is given by Fig. 390.¹³

Two 4-6-0 engines by W. Dean, built at Swindon for the G.W.R., remain to be mentioned.

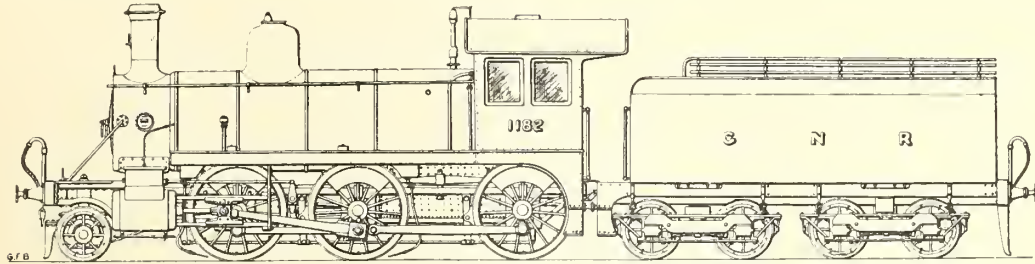

FIG. 389—BALDWIN LOCO. WORKS GOODS ENGINE, GREAT NORTHERN RLY., 1899

1900 were the eighty American bar-framed locomotives imported by the M.R. (40), G.N.R. (20), and G.C.R. (20) in 1899-1900, when British firms were so fully employed that they could not accept orders. They were all broken up between 1909 and 1915.

One of the 20 Baldwin engines for the Great Northern Railway is shown by Fig. 389. They had cylinders 18in. by 24in. and coupled wheels 5ft. 1½in. in diameter. Working pressure 175 lb. per square inch.

4-6-0 Goods Engines.—The first fifteen 4-6-0 engines were built for the Highland Railway in 1894 by Sharp, Stewart to the designs of D. Jones. They had outside cylinders, 20in. by 26in., the pistons being without tail rods;

The first, No. 36 of 1896,¹⁴ was the only engine of its type. The cylinders, 20in. by 24in., were inside. The coupled axles had inside and outside bearings, and the bogie had Mansell wood wheel centres and outside bearings. The fire-box casing of the round-topped type was raised above the barrel, and the smoke-box was extended. The boiler contained 150 *Serve* ribbed tubes, 2½in. diameter outside and 14ft. 3⅓in. long, of which the heating surface on the water side was 1402 square feet. The fire-box was shallow to allow it to lie above the frames, and had 115.8 square feet of heating surface, making the total 1517.8 square feet, but the grate had no less than 35 square feet area; pressure, 165 lb. The coupled wheels were 4ft. 6in. and the bogie wheels 2ft. 8in. diameter;

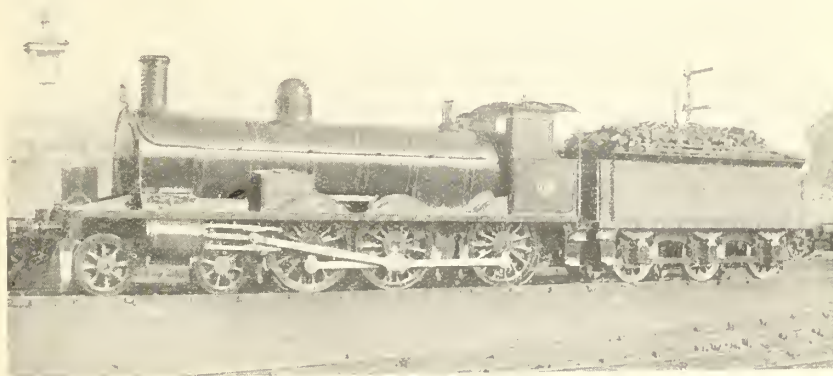

[Photo. Locomotive

FIG. 390—D. JONES'S 4-6-0 GOODS ENGINE, HIGHLAND RLY., 1894

balanced slide valves working on vertical faces inside the frames; coupled wheels, 5ft. 3in.; bogie wheels, 3ft. 2in. diameter; wheel base, 6ft. 6in. + 5ft. 3in. + 5ft. 6in. + 7ft. 9in. The middle coupled wheels were the drivers and had no flanges. Tube heating surface, 1559 square feet; total, 1672.5 square feet; grate area, 22.6 square feet; pressure,

wheel base, 5ft. 6in. + 4ft. 10in. + 6ft. 8in. + 8ft. = 25ft.; weight in working order 59½ tons, of which 47.2 tons were carried on the coupled

¹³ Working drawings and specifications appeared in *THE ENGINEER*, December 14th, 1894, and a description in the *LOCOMOTIVE*, May, 1917.

¹⁴ Illustrated in *THE ENGINEER*, November 5th, 1897, and the *LOCOMOTIVE MAGAZINE*, June, 1897.

wheels. The engine was broken up in 1905, as it was not of the standard types subsequently adopted.

The second engine, No. 2601 of 1899, is shown by Fig. 391; with the exception of the double

6 cwt., front coupled 16 tons, driving 18 tons, trailing 17 tons 10 cwt., total 63 tons 16 cwt.

0-8-0 *Mineral Engines*.—The first 0-8-0 engine with inside cylinders was built by F. W. Webb at Crewe for the L. and N.W.R. in October, 1892,



FIG. 391.—W. DEAN'S 4-6-0 GOODS ENGINE, GREAT WESTERN RLY., 1899

frames and outside bearings for the coupled wheels only, it differed entirely from No. 36. The inside cylinders were 19in. by 28in.; the bogie wheels were 2ft. 8in. diameter, with inside bearings; coupled wheels, 4ft. 7½in. diameter. Spiral springs were used in place of the laminated springs of No. 36. The boiler had a raised Belpaire fire-box, the upper part of which was extended towards the front to form a combustion chamber. The sand-box was placed as a saddle on the barrel. Wheel base, 5ft. 6in. + 4ft. 6in. + 7ft. 6in. + 7ft. 6in.; boiler barrel, 10ft. 6in. long by 4ft. 8½in. diameter outside the smaller ring. The length of the inside fire-box was 6ft. 4¾in., and that of the combustion chamber 3ft. 6in. The

and was illustrated in *The Engineer*, December 23rd, 1892. It was a non-compound engine with 19½in. by 24in. cylinders and 4ft. 5½in. wheels. The boiler was similar to that of the "Greater Britain" compound passenger engine with two lengths of tubes separated by a combustion chamber. Wheel base, 17ft. 3in., equally divided; total heating surface, 1245.3 square feet; pressure, 160 lb.; weight in working order, 46 tons 16¾ cwt. Joy's valve gear was used and the crank axle had a central bearing. The coupling-rods were similar in principle to that of J. F. Stephenson, and all three pieces were interchangeable. This was the only eight-coupled non-compound engine built by Webb.

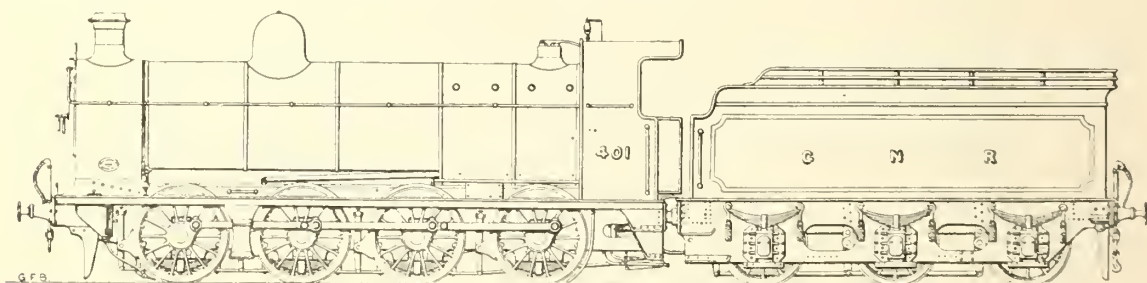

FIG. 392.—H. A. IVATT'S 0-8-0 MINERAL ENGINE, GREAT NORTHERN RLY., 1900.

324 tubes, 1½in. diameter, gave a heating surface of 1712.9 square feet, and the fire-box and combustion chamber 166.8 square feet; total, 1879.7 square feet; grate, 32.19 square feet; pressure, 180 lb.; weight in working order, bogie 12 tons

Sir John Aspinall's L. and Y.R. 0-8-0 engines, also with inside cylinders and Joy's gear, were built at Horwich early in 1900.¹⁵ Cylinders, 20in.

¹⁵ See *THE ENGINEER*, March 1st, 1901, and the *LOCOMOTIVE MAGAZINE*, August, 1900.

by 26in.; wheels, 4ft. 6in. diameter; wheel base, 16ft. 4in.; boiler, 15ft. long by 4ft. 10in. diameter; fire-box of Belpaire type; heating surface of tubes, 1877 square feet; total, 2038.6 square feet; grate area, 26 square feet; pressure, 175 lb.; weight in working order, 53.77 tons. The valves are of the Richardson balanced type with exhaust through the back. To avoid a long and heavy reversing rod, J. Stirling's type of steam reversing gear was fixed inside the framing near the reversing shaft.

H. A. Ivatt's first G.N.R. 0-8-0 engine—illustrated by Fig. 392—was built at Doncaster at the end of 1900. The cylinders, 19 $\frac{3}{4}$ in. by 26in., are inside, with Richardson balanced valves on the top and exhaust through the valve, but Stephenson's link motion with rocking shafts is used. Wheels, 4ft. 8in. diameter; wheel base, 17ft. 8in.; boiler, with round topped casing and direct-stayed fire-box, 4ft. 6 $\frac{1}{2}$ in. mean diameter;

link was pinned between the valve rod and valve spindle, owing to the necessity of using parts of an older engine.¹⁶

The only other example of the 2-6-0 tank engine on a British railway of standard gauge was a side tank built in 1909 by Manning, Wardle and Co., Ltd., for the Knott End Railway, and illustrated in *The Locomotive*, December 15th, 1915.

Eight-coupled Tank Engines.—Sharp, Stewart's 0-8-2 tank engines for the Barry Railway, 1896, with outside cylinders (Fig. 393), introduced an entirely new type on British railways. The cylinders were 20in. by 26in.; coupled wheels, 4ft. 3in. diameter; and wheel base, 22ft. 11in., of which 15ft. 5in. was that of the coupled axles; boiler barrel, 13ft. 5 $\frac{1}{2}$ in. long; heating surface of fire-box, 115 square feet; total, 1476 square feet; grate area, 22 $\frac{3}{4}$ square feet; pressure, 150 lb.; tank capacity, 2100 gallons; fuel, 3 $\frac{1}{2}$ tons; weight full, 74.8 tons, of which 62.8 tons were

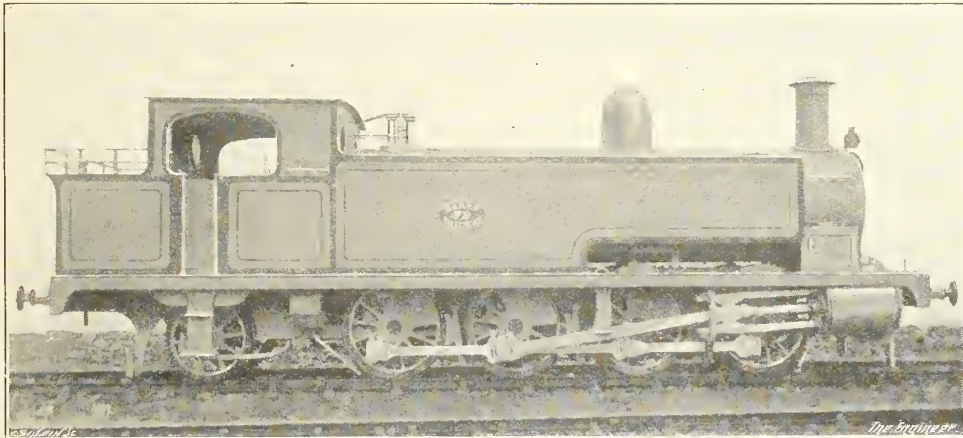

FIG. 393—SHARP, STEWART'S 0-8-2 TANK ENGINE, BARRY RLY., 1896

heating surface, $1302 + 136\frac{3}{4} = 1438\frac{3}{4}$ square feet; grate area, 24 $\frac{1}{2}$ square feet; pressure, 175 lb.; weight full, 54 tons 12 $\frac{1}{4}$ cwt. No 0-8-0 non-compound engines with outside cylinders were built during the 1890-1900 period.

2-6-0 Tank Engine.—The first of the only two tank engines of the 2-6-0 type which ever worked on a British standard-gauge line was one reconstructed in 1899 by F. Willans at the Wrexham works of the Wrexham, Mold and Connah's Quay Railway. The cylinders were inside, 18in. by 24in., and the six-coupled wheels 4ft. 8in. diameter; wheel base, 6ft. 10in. + 5ft. 3in. + 6ft. 10in.; heating surface, 1132.8 square feet; pressure, 150 lb.; tank capacity, 1500 gallons. The leading wheels were rigid and no form of radial axle was used. All the springs were of Timmis's spiral pattern. The cast iron slide valves were below the cylinders, worked directly by Stephenson gear, with the peculiarity that an offset

carried on the coupled wheels. Originally these engines had flangeless tires on the second pair of coupled wheels, but this arrangement caused the other tire flanges to wear badly. Subsequently the intermediate wheels were fitted with special tires with thin flanges.

Three similar engines were built for the Port Talbot Railway in 1901, but the type first appeared on this line with two supplied by the Cooke Locomotive Works, U.S.A., in 1899. These have 4ft. 4in. wheels and 19in. by 24in. cylinders, and having been reboilered at Swindon in 1908, are still in service. They have bar frames, outside cylinders with saddle castings, and other American features.¹⁷

¹⁶ Working drawings appeared in *THE ENGINEER*, November 21st, 1902, and it was described in the *LOCOMOTIVE MAGAZINE*, March, 1905.

¹⁷ For illustration and description see the *LOCOMOTIVE MAGAZINE*, May, 1900.

DETAILS.

Boilers and Fire-boxes.—Apart from the ultimately unsuccessful trials of intermediate combustion chambers by Webb, the principal modification was the introduction by the Manchester, Sheffield and Lincolnshire Railway in 1891 of the Belpaire fire-box on the recommendation of the then chief draughtsman, who had previously been with Beyer, Peacock and Co. The square topped casing had, however, been used previously by Bouch on the S. and D.R., so that the form was not new to this country, though the design was somewhat different. W. Dean, on the G.W.R., and Sir John Aspinall, on the L. and Y.R., adopted the Belpaire top in 1897, and it has since gradually spread to most railways.

Webb tried numerous fire-box designs. In 1889 there was a modification of McConnell's combustion chamber, in which a D-shaped chamber was attached to the front of the throat plate. The inner fire-box was of steel with corrugated sides, and the girder stays, placed transversely, were of cast steel, through which passed two longitudinal rods. Sling stays were attached to these rods.¹ There was also another steel fire-box, which consisted of two cylindrical chambers, one above the other, joined together at the fire-hole end by a connecting-neck. Each chamber was formed of two rings strengthened and joined by Adamson flanged seams, and the upper one had a D-shaped combustion chamber similar to that described above, with tube-plates at the front. The "flat" ends of both chambers had circular concentric corrugations, and the only side stays formed a row across the neck connecting upper and lower chambers. In section the fire-box and casing were somewhat like a figure 8.² Neither of the above fire-boxes went further than the experimental stage.

About 1899 Webb also tried a fire-box somewhat similar to the Verderber type on the Hungarian railways with brick walls instead of water spaces at the sides and back. The Verderber fire-box was illustrated in "Proc." Inst. Mech. Eng., March, 1906, page 198. On the L. and N.W.R. the bricks were shaken down in service and the experiment failed.

D. Drummond's cross water-tube fire-boxes, which appeared on the L. and S.W.R. in 1897 and remained standard on that line until his death in 1912, are so well known that no description is needed. They were tried on other railways, notably by P. Drummond on the Highland, but were abandoned on the L. and S.W.R. by D. Drummond's successor. One of the causes which led to their disuse was the appearance in service of minute "pinholes" through the body of the steel tubes. A well-known American engineer suggested to the writer that this defect would probably not have occurred had the tubes been of best charcoal iron.

The French Serve boiler tubes with internal ribs were tested extensively on several railways, notably the G.E.R. and G.W.R. The former line tried them as early as 1891. As far as the writer is aware they have been completely abandoned.

Smoke-boxes, Blast-pipes, etc.—H. Smellie's drum-shaped smoke-box extensions on the G. and S.W.R., which were also tried on the G.E.R. and Mersey Railway, were discarded, and in their place appeared in 1895 the American type of long smoke-box with wire netting spark arrester as on the G.W.R. It was some years later before extended smoke-boxes made much headway on other railways.

Macallan's variable blast-pipe with hinged contractor top, which could be moved to one side from the foot-plate, was the only one which had extended application here, principally on the G.E.R.

In 1897 Webb fitted some engines, including the first two with four cylinders, with double chimneys, arranged in a single casing. The exhaust from one cylinder (two in the case of the four-cylinder non-compound engine) passed into each chimney. One chimney was carried down through a horizontal partition in the smoke-box to draw the gases through the lower tubes, whilst the other drew them from the upper tubes. The idea was not new, and engines running in Chile had been fitted with a somewhat similar arrangement, the origin of which may have been American. After about two years' service Webb abandoned it.

Crank Axles.—In 1890 F. W. Webb provided some of the three-cylinder compound engines with built-up crank axles with central crank. In 1895 he tried an axle with two cranks, built up of nine pieces, in a two-cylinder goods engine.³ Whether Webb was the first in this country to try built-up crank axles the writer does not know, but they had certainly been made in 1856-58 on the Eastern Railway of France in five pieces in a different form.

Bogies.—Two novel designs of bogie made their appearance. The type of 1894 with outside frames on the G.W.R., by W. Dean,⁴ was specially designed to suit the arrangement of large cylinders with steam chests underneath, which made the attachment of the pivot by the usual method difficult. The cross stay in the middle attached to the main outside frames is curved downwards to a level some distance below the centre line of the axles. The pivot is made with a channel-shaped casting below, which is secured between the two sides of the stay, and projects upwards into the sliding block, the latter being controlled by spiral check springs. It does not bear directly on a block with circular plate, as in the usual British sliding bogie, but passes through a spherical piece which is movable inside a socket machined in the body of

¹ See THE ENGINEER, June 14th, 1889.

² See THE ENGINEER, December 6th, 1889.

³ See THE ENGINEER, May 1st, 1896.

⁴ See THE ENGINEER, June 28th, 1895.

the block. The lateral movement is about $\frac{3}{4}$ in. on each side of the centre. The block and slide carry very little weight, the latter being transferred to the bogie at the sides by means of four tension rods with thick india-rubber washers. The rods have sufficient freedom to allow for the lateral movement of the bogie.

F. W. Webb held on stoutly to his two-wheeled radial axle until 1897, when the excessive weight on a single pair of leading wheels caused him to modify the design for express engines, and use a similar arrangement for a four-wheeled truck. Kinematically, its movement is similar to that of the original four-wheeled Bissel bogie pivoted at a point behind the centre, as in the first arrangement on the Metropolitan engines, afterwards discarded. Webb's truck had curved slides and no pivot, the radius of curvature at the centre being 10ft. 9in. It was not termed a "bogie" by the designer, and whether it ought to be called one depends upon a definition which may or may not include a pivot. But that it has the advantages of a well-designed bogie of the Adams type is open to doubt. No other railway ever adopted it, though T. W. Worsdell's N.E.R. bogie was a compound of the Adams type with a curved slide.

Cylinders.—At the end of 1897 there was no British locomotive superintendent designing two-cylinder non-compound engines with outside cylinders, other than small shunting locomotives. In 1898 Ivatt's G.N.R. "Atlantic" engine appeared, and since then the use of outside cylinders has greatly increased. With the extended use of piston valves with inside cylinders it became usual to place the valves either above or below with direct drive from Stephenson's link motion, as in W. M. Smith's design. Piston tail rods, after having been tried by Adams for some years on the L. and S.W.R., were discarded on this line about 1896, and were adopted at about the same time by the N.E.R. The reason then given, alike for their adoption and disuse, was exactly the same in each case, namely, that the opposite course was productive of wear and scoring of the cylinders. Apparently the question is still *sub judice*, though the tail rods tend to disappear, partly owing to the increase of the reciprocating masses which they involve.

Valves and Valve Gears.—Piston and balanced slide valves rapidly replaced ordinary D slide valves. Balanced valves were usually arranged to exhaust through the back of the valve itself.⁵ Sir John Aspinall, on the L. and Y.R., tried a number of partially balanced valves above the cylinders, of which drawings were given in his Report on Express Locomotives, International Railway Congress, 1895.⁶

Of valve gears Allan's straight link motion

⁵ In a letter dated February 4th, 1832, Robert Stephenson writes of a "new slide valve" he had contrived "to avoid pressure of the steam . . . the steam exhausting through a hollow piston."

⁶ See THE ENGINEER, June 21st, 1895.

received its last application in 1897 on the L. and N.W.R. and also on the L. and Y.R. shunting engines with outside cylinders. The Walschaerts gear was extensively applied by Beyer, Peacock and Co. from 1890 for engines in Northern Ireland, all with inside cylinders, except a few for the 3ft. gauge. The outside cylinder engine with this gear had not yet been adopted on British railways. The single valve gear with rocking levers for the four-cylinder engines of 1897 has already been mentioned.

In 1899 R. J. Billinton, on the Brighton railway, applied a combined hand and compressed air reversing gear to the new 4-4-0 engines. The air piston-rod connected to the reversing rod is hollow and threaded to receive a screw attached to the hand wheel. The pressure of the air, which is admitted to one end of the cylinder only, counter-balances the weight of the motion, and neither balance weight nor spring is applied to the reversing shaft.

Steam Jackets.—Following Crampton's engines of 1857 for the East Kent Railway, nothing is known to have been done in regard to steam jacketing of cylinders until Sir John Aspinall made experiments on the L. and Y.R. in 1894 in conjunction with the Research Committee of the Institution of Mechanical Engineers—see "Proc." 1896. The 19in. cylinders of an express engine were bored out and fitted with liners which reduced the diameter to $17\frac{1}{2}$ in., thus providing a steam jacket of $\frac{3}{8}$ in. space. The front and back covers were also jacketed, the latter necessarily imperfectly. On the whole, the engine in service showed some economy, and in his later 4-4-2 engines of 1899, with 19in. by 26in. cylinders, Sir John Aspinall applied jackets, through which live steam passed on its way to the injector. The second batch of twenty similar engines built in 1902 were without jackets. Sir John also tried hot gas jackets, in which the cylinders were surrounded by smoke-box gases. Although the jacket temperature rose to about 470 deg. Fah., the economy expected did not result.

Superheating.—In 1899 Sir John Aspinall provided a smoke-box superheater for one of the L. and Y.R. 4-4-2 engines, and five similar engines of 1902 were similarly fitted. The principle was somewhat similar to that of McConnell's superheater of 1852, but was carried out differently. It was described and illustrated in "Proc." Inst. Mech. Eng., June, 1900, pages 409-410, to which reference may be made.

Oil Fuel.—James Holden's liquid fuel apparatus of 1893 on the G.E.R., which has been extensively applied abroad, is so well known as not to require description. Although a paper on trials by Mr. Aydon was read in 1878 before the Institution of Civil Engineers, the first practical and successful application of liquid fuel burning in locomotives was made by another British engineer, Thos. Urquhart, on the Grazi-

Tsaritsin Railway, Russia, where in 1884 there were more than 100 locomotives fitted for burning petroleum refuse.

On the G.E.R. there were at one time about sixty engines in service on Holden's system, the usual fuel being tar from gasworks. In spite of its practical success the system was not extended further on this line owing to the rise in price of the fuel beyond a point at which it could economically compete with coal.

Locomotive Speeds and Performances, 1880 to 1900.—Space will not permit of detailed consideration of this subject, but a few general observations may be made. In 1884 Rous-Marten recorded a long series of timings on British railways, which formed the subject of a report to the New Zealand Government. In this he stated that the ordinary limit of attainable velocity was somewhere about 75 miles per hour. It was not commonly attained and seldom exceeded, but rates of 70 to 73 miles per hour downhill were reached by many trains. On three occasions he registered 76½ miles per hour with a G.W.R. 8ft. broad-gauge single, a G.N.R. 8ft. "Stirling" single, and a M.R. 7ft. coupled engine.

The writer has records made in 1886-88 of 76 miles per hour with a Midland 7ft. 4-4-0 engine having 19in. by 26in. cylinders and Joy's gear, and also with a G.N.R. 8ft. single, and of 75 miles per hour with a Midland 7ft. 2-4-0 engine, the cylinders of which were 18in. by 26in. Pressure of all three engines 140 lb. In all cases these maximum speeds were attained on long descending gradients of 1 in 200 with trains of 90 to 120 tons. In 1887 he recorded an exceptional speed of 81.8 miles per hour with a G.W.R. broad-gauge 8ft. single engine and a load of four eight-wheeled bogie coaches down the Wellington bank between Whiteball Tunnel and Taunton, when the engine was being driven to attain the maximum speed possible.

The race to Edinburgh in August, 1888,

between the East and West Coast routes attracted much attention. The daily records of the Great Northern engines were given in *The Engineer*, December 16th, 1892, page 535, and considerable information in regard to the locomotive performances of all the four railways concerned also appeared in most of the engineering journals at the time.

The loads of the fastest trains until 1889 did not usually exceed 150 tons, though trains of 200 to 240 tons were sometimes taken. Much of the carriage stock was six-wheeled. During the last decade of the century the loads increased considerably, and a number of the fastest expresses averaged 200 to 225 tons, and some even more. But this increase was accompanied by a decrease in train resistance, partly owing to the replacement of six-wheeled by eight-wheeled bogie carriages, and partly to the use of heavier rail sections and harder tires.

At the same time there was a considerable increase in the average, and a remarkable, though gradual, increase in maximum speeds from 75 miles per hour in 1885-88 to 90 miles per hour in 1897. Those interested should refer to two articles by Rous-Marten in *The Engineer*, December 14th, 1894, and December 31st, 1897, in which he traced this gradual growth.

The effect on speed of harder tires has been referred to previously by the writer. As the hardness increased so did the speeds, even of older engines in which no other alteration had been made. The writer repeatedly noted that engines, which in 1886-88 never exceeded 73 miles per hour, were in 1898-1900 attaining maxima of 80 to 82 in ordinary service, some of the trains during both periods consisting almost entirely of bogie vehicles. Moreover, these increased speeds were run with trains of 150 to 170 tons weight, compared with those of 90 to 120 tons in 1886-88. Rous-Marten's recorded observations of train speeds, loads and gradients appeared in *The Engineer* from about 1890 onwards.

Chapter XXI

Articulated, Steep Gradient and Miscellaneous Locomotives

ARTICULATED LOCOMOTIVES.—*General.*— In the previous chapters, which bring the British locomotive down to the end of the nineteenth century, double articulated locomotives have been omitted, and therefore a short section will now be devoted to them.

The first double locomotive, which took the form of two 2-2-0 engines back to back with a double boiler and single fire-box, was built in 1831 for the S. Carolina R.R. by the West Point Foundry, N. Y., to Horatio Allen's designs. Each pair of wheels with their frames formed a bogie at each end. This engine, which was illustrated in *Engineering*, 1871, and also by Lieut.-Col. E.

wheels, 3ft. 6in. diameter; heating surface: tubes 752.8 sq. ft., fire-box 70.7 sq. ft., total 823.5 sq. ft.; grate area, 10.8 sq. ft.; working pressure, 140 lb. per sq. in.; weight in working order, 30 tons 16 cwt.

In 1875 Kitson and Co. built similar twin tank engines, each of the 2-6-0 type, for the Cape Government Railways. The regulator and reversing gears were separate, so that each engine could be used independently.

In 1889 the principle reappeared in double 2-6-0 tank engines by Beyer, Peacock for the Inter-oceanic Railway of Mexico, 3ft. gauge. These engines were constructed in accordance with

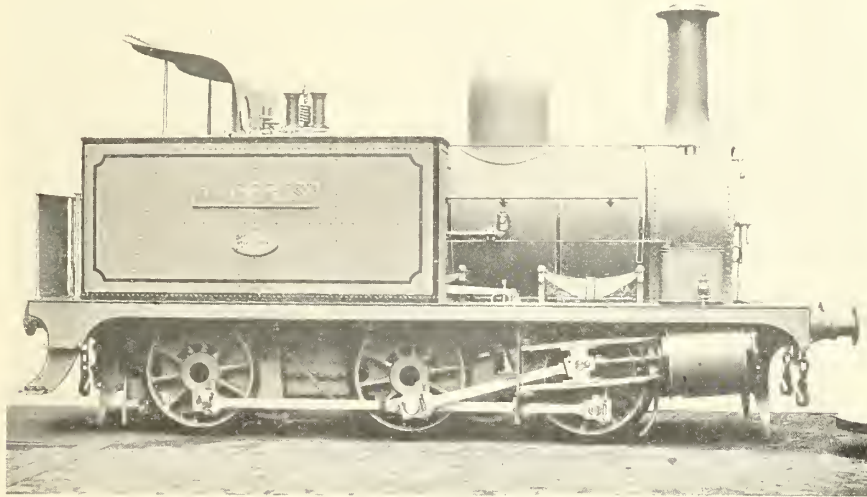

FIG. 394—SHARP, STEWART'S LOCOMOTIVE FOR BACK TO BACK WORKING, CORNWALL MINERALS RLY., 1873-74

Kitson-Clark (*Inst. Loco. Eng.*, 1920), was in principle the forerunner of the Fairlie engine.

Twin Locomotives Back to Back.—The *Giovi* engines by R. Stephenson, 1855, have already been described—see page 141 *ante*. They consisted of two separate tank engines coupled together and did not involve any application of the bogie principle.

In this country the principle was applied on the Cornwall Minerals Railway, for which line Messrs. Sharp, Stewart and Co. built 18 (nine pairs) 0-6-0 side tank engines in 1873-74. One of these is illustrated by Fig. 394.

These engines were designed by Mr. F. Trevithick, locomotive engineer of the C.M. Railway, and had cylinders 16½ in. diameter by 20 in. stroke;

Lange and Livesey's patent. Each of the two combined engines had a long continuous draw-bar extending from the front of the engine to the back of the foot-plate, where the two bars were jointed together. The buffing castings between the engines were formed with slightly convex surfaces. The two regulators were connected by means of levers and a rod under the cab roof. The reversing gear of each engine was on the right-hand side, looking towards the chimney, and the two were worked in unison by means of a cross shaft at an angle of about 45 deg. underneath the foot-plates. Rotation of the shaft was produced by bevel gears at each end, the horizontal wheels of which were keyed to vertical shafts one on each foot-plate. Each of these shafts had a

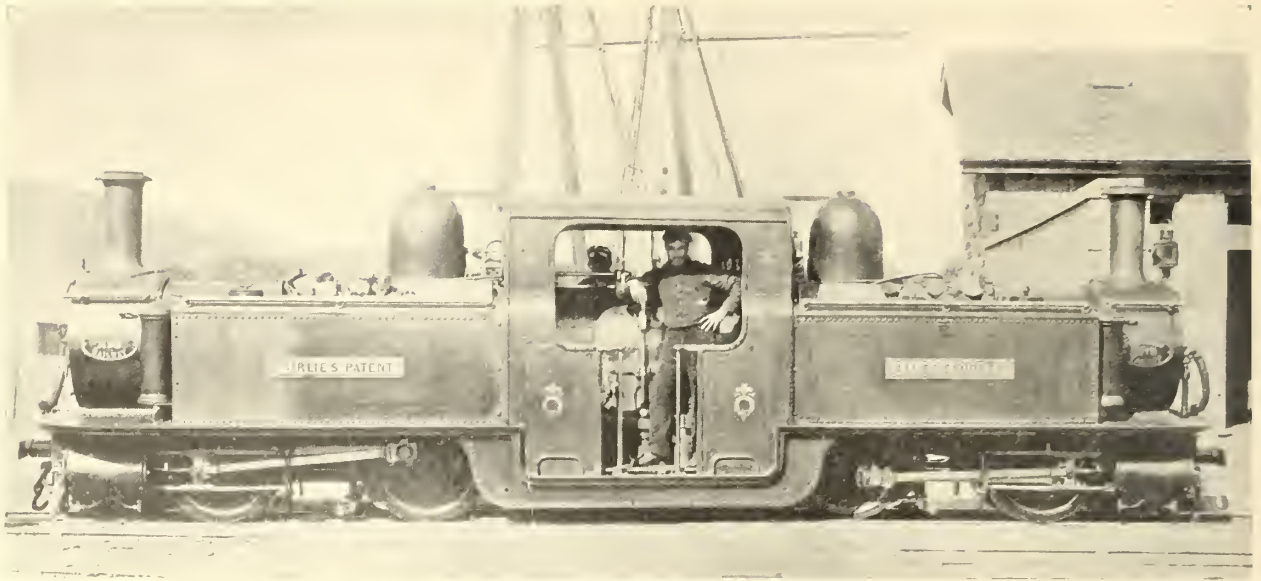

[Photo. Locomotive

FIG. 394A—FAIRLIE ENGINE FOR THE FESTINIOG RLY., NORTH WALES. BUILT BY AVONSIDE ENGINE CO., 1872

handle at the top, by turning which the driver reversed both engines. The movement was communicated to each weigh-bar shaft by a worm wheel on the vertical shaft, which geared with a quadrant on a bell-crank lever underneath the foot-plate.

A modification of the type with tender was adopted in 1890, when Neilson and Co. built twenty double 0-6-0 engines for the North-Western State Railway, India, for the steep gradients on the Sindh-Pishin lines. These engines, each of which had 19in. by 26in. outside cylinders and 4ft. 2in. wheels, were arranged with one tender coupled between the two.

two steam bogies by means of pivots fixed in supports, on which the barrels rested. The steam pipes were outside and connected to the cylinders through stuffing-box joints. The cylinders were inside and the exhaust was connected with the blast-pipe through a ball and socket joint. For complete drawings see Couche's "Voie et Matériel Roulant."

The original Fairlie engines differed from the above only in certain details. Instead of two fire-boxes, a single fire-box common to both barrels and fired from the side was used. The pivots were fastened to the barrels instead of to the supports as in the Seraing engine, and the copper steam

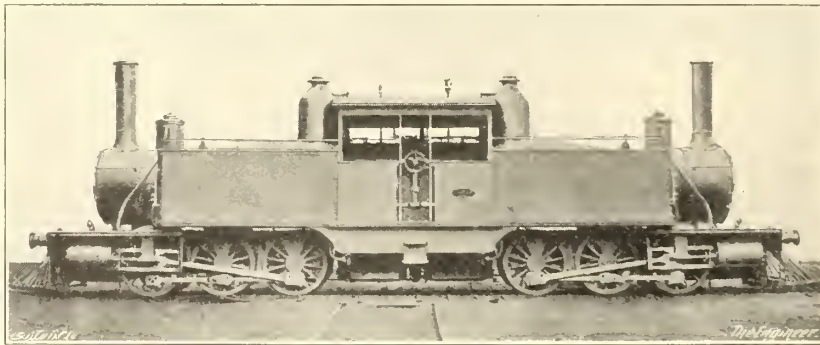

FIG. 394B—FAIRLIE ENGINE. FOR THE MEXICAN RLY., YORKSHIRE ENGINE COMPANY, 1872

Fairlie Double Locomotives.—Fairlie's well-known type in nearly all its principal features appeared in 1852 in a 0-4-4-0 engine by Cockerill, of Seraing, for the Semmering incline trials in Austria. This engine had a double boiler, each part with an independent fire-box, both boxes being in one casing. The boilers were carried on

pipes inside the smoke-box were bent round the latter and coiled or uncoiled slightly as the bogies swivelled. These pipes were taken to the outside cylinders through slotted apertures in the bottom of the smoke-boxes. The apertures were covered with sliding plates. The first Fairlie engine, "Progress," was built to Robert Fairlie's designs

by James Cross and Co., St. Helens, for the Neath and Brecon Railway in December, 1865, and was of the 0-4-4-0 type with four 15in. by 22in. cylinders, 4ft. 6in. wheels, and weighed 42 tons. There was no water partition in the single fire-box and the draught from one chimney tended to draw air down the chimney at the opposite end. Fairlie stated that this error was due to the builders, who decided that a water partition would be disadvantageous. In service the coiled steam pipe caused trouble and finally gave way on a sharp curve; afterwards Fairlie substituted a "pendulum" steam pipe.

Cross & Co. built a second engine in 1866 for the Anglesey Central Railway. It had 4ft. wheels and four 10in. by 16in. cylinders. Wheel base of each bogie, 5ft.; total base, 19ft. 11in. Each boiler barrel was carried on a forging riveted to the underside, and the lower part of each forging formed a pin 5in. diameter. In addition to the bogie frames there was a connecting frame round the fire-box casing. The exhaust pipes had a ball

fire-boxes, 2ft. 8½in. by 2ft. 1in. Boiler pressure, 140 lb. per sq. in.; heating surface tubes, 629 sq. ft.; fire-boxes, 84 sq. ft.; total, 713 sq. ft. Grate area, 11.2 sq. ft. Capacity of tanks, 720 gallons. Weight in working order, 20 tons 1 cwt.

The Fairlie type of engine was built in large numbers by the Avonside Engine Company, Yorkshire Engine Company, and Vulcan Foundry, principally for Russia, Sweden, Mexico, and South America. A 0-6-6-0 engine by the Yorkshire Engine Company of the 1872 to 1883 type for Mexico is shown by Fig. 394B. It had 3ft. 6in. wheels, 16in. by 22in. cylinders, and "wagon top" boiler barrels. A more modern engine by Neilson for the same railway is illustrated by Fig. 395. These engines are built to the standard gauge (4ft. 8½in.), and have wheels 3ft. 6in. diameter, four cylinders 16in. by 22in.; the wheel base of each bogie is 8ft. 3in., and the total wheel base 32ft. 5in. The distance between bogie pivots is 22ft. 8in. The tube heating surface is 1532 sq. ft. and that of the

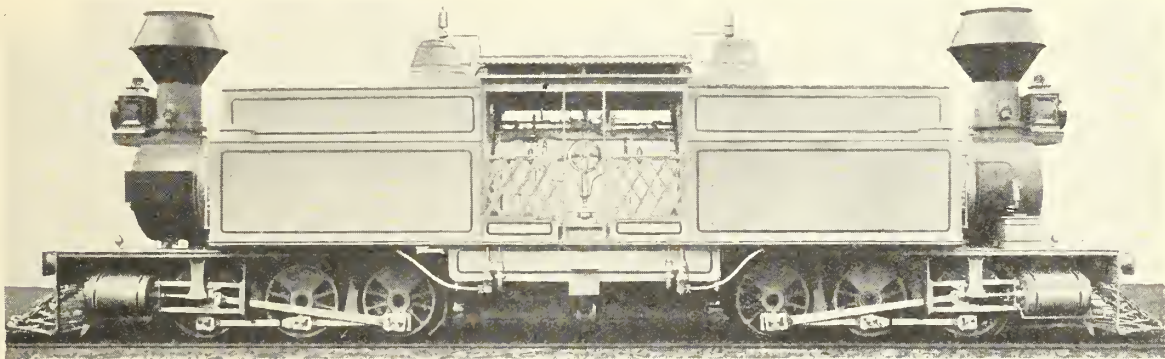

FIG. 395—NEILSON'S FAIRLIE LOCOMOTIVE, MEXICAN RLY., 1889

and socket joint, and the fire-box had a water space partition.

During 1869-72 the chief improvements consisted in the substitution of a circular bogie centre casting in place of the pivot pin, and the adoption of ball and socket joint connections for the steam pipes below the smoke-box. The buffing gear was attached to the bogies in all Fairlie's engines.

Only some half-dozen Fairlie engines were used on the standard gauge railways in this country, in addition to a few on the Festiniog Railway, 1ft. 11½in. gauge.

One of the latter provided with *two* inside fire-boxes is illustrated by Fig. 394A. It was built in 1872 by the Avonside Engine Co., of Bristol, and named "James Spooner," after the engineer who laid out the line. The main particulars of this engine are: Cylinders, 8½in. diameter by 14in. stroke; wheels, 2ft. 8in. diameter; bogie wheelbase, 4ft. 6in. each; total, 18ft. 8in. Boilers, 7ft. 7in. long by 2ft. 7in. diameter; 102 tubes in each, 1½in. diameter. Outside fire-box, 6ft. 4in. by 2ft. 7¼in.; inside

fire-box 180 sq. ft.; total, 1712 sq. ft. Grate area, 33 sq. ft. The weight in working order is about 94 tons. With a boiler pressure of 165 lb. per square inch they exert a draw-bar pull of 17 tons. Owing to a brake mishap, one of these engines once broke loose from its train and ran away for a distance of nearly seven miles over the worst portion of the 1 in 25 gradient. Although the speed rose to more than 60 miles per hour, and the engine had to traverse reverse curves of 350ft. to 400ft. radius, one of which describes more than a complete semi-circle, it reached the bottom in safety, and was then stopped without any damage to any part of the motion or framing.

The largest Fairlie engines (0-6-6-0) were built in 1911 by the Vulcan Foundry for the Mexican Railway, to haul 300-ton trains over gradients of 1 in 25 and reverse curves of 330ft. radius. The weight in working order is 138 tons, or 23 tons per axle. The four cylinders are 19in. by 25in.; wheels, 4ft. diameter; heating surface, 2924 square feet; pressure, 185 lb.

The Vulcan Foundry introduced important

improvements in Fairlie engines. In the engines of 1901 for Burma,¹ the boilers are separated and carried on a deep girder frame, at the extremities of which the bogie pivots are arranged 8in. behind the bogie centre, instead of at the centre as in previous designs.

hind bogie on lateral supports, and on the front bogie by means of a spherical pivot. All four cylinders were arranged in the middle. An improved 0-6-6-0 engine of this type for the Grand Central Belge Railway was shown at Vienna in 1873.

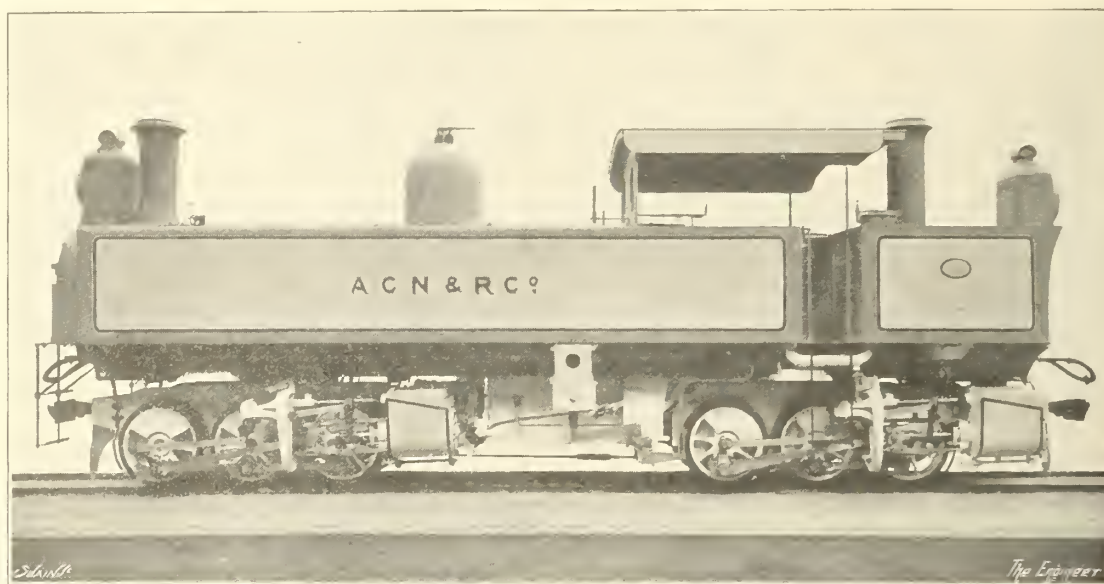

FIG. 396—ARTICULATED KITSON-MEYER LOCOMOTIVE BY KITSON & CO., LTD., FOR THE ANGLO-CHILIAN NITRATE AND RAILWAY COMPANY, 1894

A type of double Fairlie locomotive, not generally known, was a fast passenger engine of the 2-4-4-2 type with inside cylinders. Some examples with 5ft. 6in. coupled wheels were built in this country for the Great Russian Railway about 1871-72.

Kitson-Meyer Locomotives.—In the original Meyer design, of which drawings were shown at the London 1862 Exhibition and a description

In 1894 Robert Stirling, of the Anglo-Chilian Nitrate & Railway Co., suggested to Kitson & Co. a design on the lines of the Meyer type. On this line there is a section 17 miles long of 1 in 25 gradient, 75 per cent. combined with curves of 181ft. radius. An illustration of one of these 0-6-6-0 articulated engines by Kitson is given by Fig. 396. The boiler, together with the tank and bunker, are supported on a pair of girders, which,

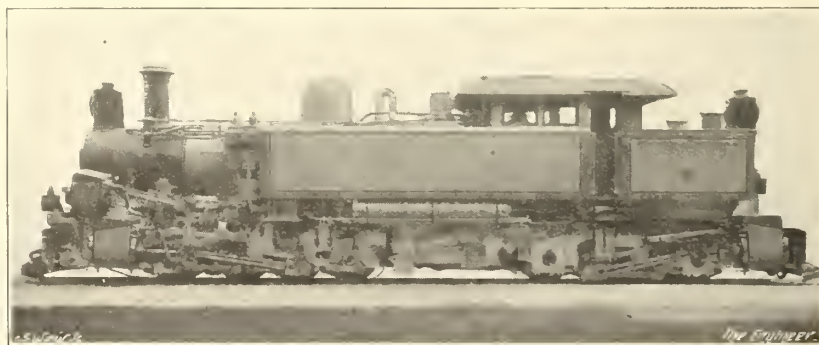

FIG. 397—KITSON-MEYER RACK LOCOMOTIVE, TRANSANDINE RLY., 1909

given in Colburn's "Locomotive Engineering," page 91, there was no main frame, the buffing gear being carried by the bogies. The boiler, which was of the single locomotive type, rested on the

¹ See THE ENGINEER, May 16th, 1902.

in turn, rest upon the bogies. The four cylinders are 14in. by 18in.; wheels 2ft. 10 $\frac{3}{4}$ in. diameter; bogie wheel base 6ft. 2 $\frac{1}{2}$ in.; total wheel base 25ft. 6 $\frac{1}{2}$ in.; heating surface 1168 sq. ft.; pressure 160 lb. per sq. in. Weight fully loaded 55 tons

7 cwt. Tractive force 24,000 lb. The largest Kitson-Meyer engines were built in 1908 for the Great Southern Railway of Spain, and are of the 2-8-8-0 type, with 4ft. wheels, four 14 $\frac{3}{4}$ in. by 24in. cylinders, 180 lb. pressure, tank capacity 2300 gallons, and total weight 101 tons.

This system is well adapted for combined rack and adhesion locomotives. Fig. 397 shows such an engine by Kitson for the Transandine Railway (metre gauge) in 1909. The front unit is a combined adhesion and small rack engine, and the back unit a large rack engine only. The small rack engine with the extra pair of cylinders in front was specified by the railway. The front adhesion unit has eight coupled wheels, 3ft. diameter, the frames being outside. The cylinders are 16 $\frac{1}{2}$ in. by 19in. The rear steam bogie which forms the principal rack engine is supported on six carrying wheels. The two additional driving axes, on which the rack pinions are fixed, are carried in bearings in outside frames, these frames being supported on the axle bearings of the carrying wheels. This rack engine has the usual two cylinders, 18in. by 19in., driving the leading rack axle, to which the back rack axle is coupled. The supplementary or small rack engine consists of an additional pair of inclined cylinders, 13in. by 14in., fixed on the adhesion bogie, which drive a single rack pinion. The object of this supplementary rack engine was to provide stand-by power in case the adhesion engine proved unreliable owing to ice on the upper sections of the railway. It was found that the adhesion engine could haul the weight of the engine itself on the difficult sections, and that the two rack wheels of the rear unit provided sufficient hauling power for the train. Therefore in the later engines of 1912, the supplementary rack engine was abandoned, and a simpler engine, in which the front unit consisted of an adhesion engine only, resulted.

The total wheel base of the engine just described is 31ft. 2 $\frac{1}{2}$ in.; fire-box heating surface, 130 square feet; total, 1898 square feet; pressure, 200 lb.; tank capacity, 2100 gallons; weight in working order, 90.8 tons, of which 50.65 tons rest on the coupled wheels.

Mallet Compound Engines.—This type, invented by Anatole Mallet, and originally made in France in 1887 for narrow-gauge Decauville railways, has only one bogie, placed in front and connected at the back to the main frame of the engine by a king pin. The front of the boiler rests on the truck on cradle supports, and the back is fixed to the main frame. The high-pressure cylinders drive the rear bogie, and the low-pressure cylinders the front bogie.

There are no Mallet engines on railways in this country, but the North British Locomotive Company has built many for Burma, China, Uganda and South Africa. One of these for South Africa (3ft. 6in. gauge)—Fig. 398—was at the time the largest engine in the world for a railway of less

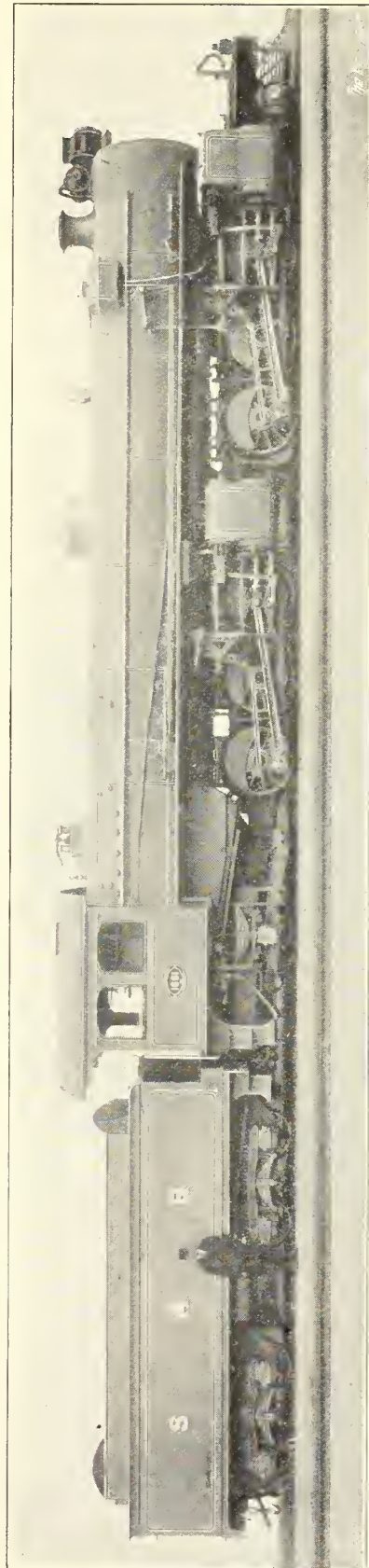

FIG. 398—MALLET COMPOUND LOCOMOTIVE, NORTH BRITISH LOCOMOTIVE COMPANY, LID., SOUTH AFRICAN RAILWAYS, 1915

than 4ft. 8½in. gauge. The high-pressure cylinders are 20in. by 26in., and the low-pressure 31½in. by 26in.; diameter of coupled wheels, 4ft.; diameter of boiler at first ring, 5ft. 11in.; distance between tube-plates, 22ft.; centre from rails, 7ft. 10½in.; heating surface, tubes 2961 square feet, fire-box 250 square feet, total 3211 square feet; superheater surface, 618 square feet; grate area, 53 square feet; pressure, 200 lb.; weight in working order, 128.25 tons; on coupled wheels, 105.65 tons; maximum axle load, 18.2 tons; weight of tender, full, 51.4 tons.

The Garratt Engine.—This type is the invention of the late H. W. Garratt. The boiler is of the single locomotive type, and, instead of being placed above the wheels is carried on a girder frame which is pivoted and supported at its extreme ends on bogies. The fuel and water tanks form integral parts of the bogies and are placed at each end of the engine. No side tanks are employed, and the whole of the space between the bogies is available for a large boiler, of which the

arrangements, the 2-6-2—2-6-2 being the most usual. Amongst the most interesting are the 2-4-0—0-4-2 express engines—Fig. 399—for the Sao Paulo Railway, Brazil (5ft. 3in. gauge). This illustration shows clearly how the girder frames carrying the boiler can be placed at such lateral distance apart as to bring them outside the wheels. The four cylinders are 16in. by 24in.; diameter of coupled wheels, 5ft., of carrying wheels, 3ft. (the latter having Cortazzi axle-boxes); boiler, 10ft. long by 5ft. 4½in. diameter, outside at the front; height from rail, 8ft. 6in.; tube heating surface, 1396 square feet; fire-box, 145 square feet; total evaporating surface, 1541 square feet; superheating surface, 304 square feet; grate, 30 square feet; wheel base of each unit, 7ft. 10in. + 6ft.; total wheel base, 47ft. 10in.; tank capacity, 1500 gallons; fuel, 2½ tons of coal.

A feature of these engines is the excellent weight distribution; the weight per axle is extremely low, but the total adhesive weight is large. The latter amounts to 55.72 tons, and the total weight in

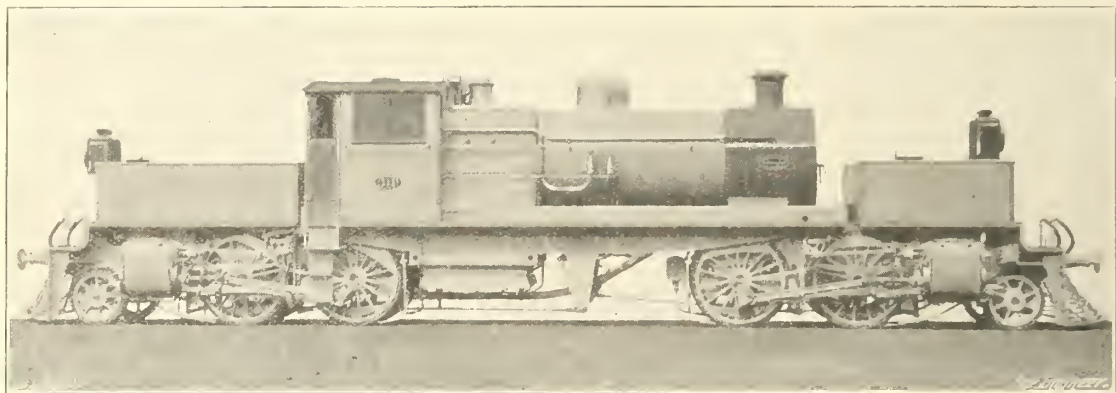

FIG. 399—GARRATT PASSENGER ENGINE, BEYER, PEACOCK & CO., for the SAO PAULO RLY., BRAZIL, 1916.

diameter and grate width are restricted only by the structural gauge and not by the wheels, giving also special facilities for washing out. There are no overhanging ends of either frame or boiler tangential to a curve. The pivots do not coincide with the bogie transverse central lines, but are located nearer to the boiler, thus increasing the resistance of the bogies to oscillation.

The Garratt engines are made by Beyer, Peacock, and the first, a small 0-4-4-0 engine, was built in 1909 for a Tasmanian Railway, 2ft. gauge. This was a compound engine, as specified by the railway, with two high-pressure cylinders on the hind bogie and two low-pressure cylinders on the front bogie. Compounding is no necessary part of the Garratt system, and succeeding engines have been of the four-cylinder high-pressure type, with the exception of some 4-4-2—2-4-4 passenger engines for Tasmania, for which the locomotive department specified four high-pressure cylinders for each unit, or eight cylinders in all.

The engines have been built with various wheel

working order to 80.47 tons, of which each unit carries exactly one-half. All four coupled axles carry the same load—13.93 tons.

The first Garratt engine in this country was supplied at the end of 1923 to Messrs. Vivian and Sons, Swansea, but recently a large engine has been placed in service on the Worsborough Dale loop line of the L. and N.E.R., near Barnsley, for heavy mineral train service, and is illustrated by Fig. 400. It is of the 2-8-0—0-8-2 type, with six 18½in. by 26in. cylinders, three at each end, and 4ft. 8in. coupled wheels. Each unit has a total wheel base of 26ft. 6½in., and a coupled base of 17ft. 10½in.; the total combined wheel base is 79ft. 1in.; the boiler is 7ft. maximum diameter outside, the length between tube-plates being 12ft. 5in.; the grate is 8ft. 5½in. by 6ft. 8in. inside; area, 56.4 square feet; tube heating surface, 2757 square feet; fire-box, 237 square feet; total evaporative surface, 2994 square feet; superheating surface, 646 square feet; pressure, 180 lb.; total weight, about 178 tons.

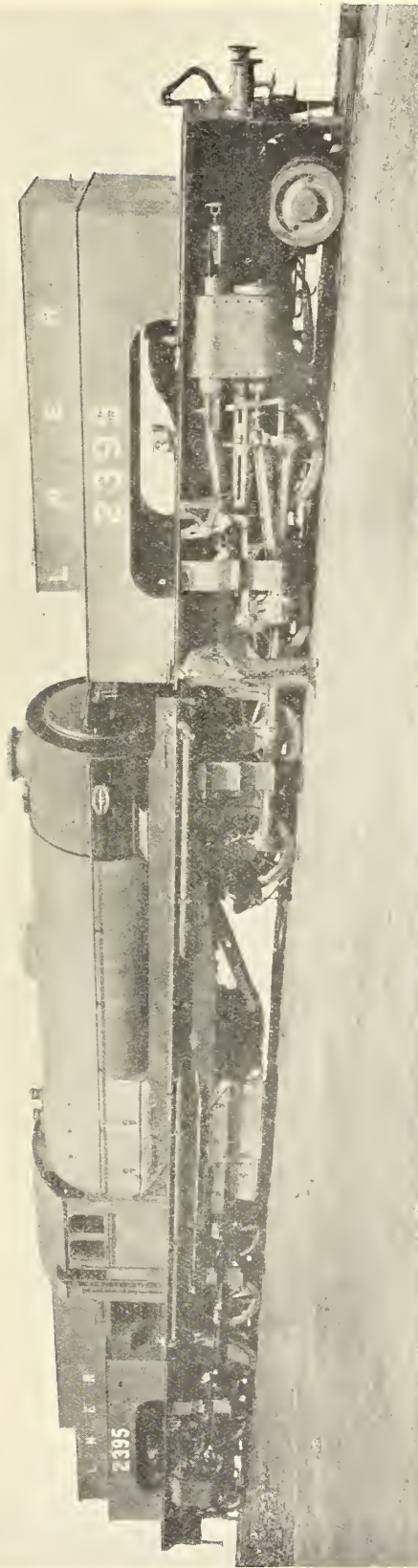

FIG. 400—SIX-CYLINDER GARRATT LOCOMOTIVE, BY BEYER, PEACOCK & CO., LTD., LONDON & NORTHEASTERN RLY., 1925

Fell Engines for Steep Gradients.—The central friction rail system for extra adhesion was first patented in 1830 by Vignoles and Ericsson. The central rail consisted of an iron bar, against each side of which bore a horizontal friction roller; motion to these rollers was communicated by the locomotive driving axle through bevel wheels. The rollers were brought into action by a lever. Colburn stated that engines on a similar system by Sellers were built for the original Panama Railroad, but were not used. This would be about 1848-49.

J. B. Fell patented his central rail system in 1863, using a double-headed rail laid horizontally midway between the ordinary rails. The first engine, built in 1863 by Brassey and Co., of the Canada Works, Birkenhead, had two outside cylinders, 11 $\frac{3}{4}$ in. by 18 in., which drove four coupled vertical wheels, 2 ft. 3 in. diameter, running on the usual rails. Two inside cylinders, 11 in. by 10 in., drove the horizontal wheels, 1 ft. 4 in. diameter, by connecting-rods. These wheels were pressed against the rail by a force of 16 tons by means of a combination of levers and bevel wheels, worked from the footplate, which caused the rotation of a transverse shaft with right and left-hand screw, which engaged in nuts attached to movable bearings of the central wheels. There were additional guide wheels acting on the central rail at the trailing end. The total weight of the engine in working order was about 14 $\frac{1}{2}$ tons, and it carried 120 lb. pressure.

This experimental engine was intended to test the system for application to the Mont Cenis Railway. It was tried on a track, 800 yards long, of 3 ft. 7 $\frac{3}{4}$ in. gauge, laid on a gradient of 1 in 13 $\frac{1}{2}$ on the High Peak Railway, Derbyshire. The subsequent Fell engines for the Mont Cenis Railway, by Gouin, of Paris, differed in having only two cylinders which drove both vertical and horizontal wheels. For full description, see Captain Tyler's paper, "Proc." Inst. C.E., Vol. XXVI.

Fell engines with four cylinders were built by Manning, Wardle in 1872 for the Cantagallo Railway, Brazil, and by the Avonside Engine Company, 1875, for the Rimutaka incline, New Zealand. A full description of the latter, taken from a paper by R. F. Alford, read before the Society of Engineers, was given in *The Engineer* of November 24th, 1882. There are two items of interest in the details. The valve gear was of the modified Walschaerts type, in which the travel movement of the link was obtained through a cross shaft from the opposite side of the engine, as in the original Stéuart gear in Belgium, and the more modern Deeley motion on the Midland Railway. The blast pipe had a central nozzle for the exhaust from the inside cylinders and an annular space for that from the outside cylinders. This arrangement is used on Beyer, Peacock's Garratt engines.

Two side tank engines on Fell's central rail sys-

tem—see Fig. 401—were built by Neilson and Co. in 1886 and sent to New Zealand for use on the Rimutaka incline of 1 in 15 (3ft. 6in. gauge).

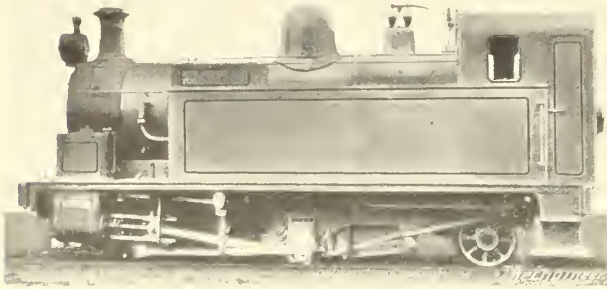

FIG. 401—FELL'S CENTRAL RAIL LOCOMOTIVE FOR NEW ZEALAND RLYS., BY NEILSON & CO., 1886

The outside cylinders, 14in. by 16in., drove the four-coupled adhesion wheels, which were 2ft. 8in. diameter, and the inside cylinders, 12in. by 14in.,

shafts. The weight in working order was 37 tons.

Rack Rail Locomotives.—The only rack railway in Great Britain is the Snowdon Mountain Railway, for which five locomotives were built by the Swiss Locomotive Works, Winterthur, in 1895-96. One of these is illustrated by Fig. 403. They are of the 0-4-2 Abt type, with horizontal cylinders placed above the platforms near the middle. The piston-rods at the front ends of the cylinders actuate a heavy rocking lever, to which the outside connecting-rods are attached. Three more engines of similar type, fitted with superheaters, have since been built by the same firm, 1921-24.

Rack locomotives of various designs have been built by several British builders for overseas. The first, of a unique design, were built in 1887 by Beyer, Peacock, for the Puerto Cabello and Valencia Railway, South America, on Lange and Livesey's patent. The rail wheels are carriers only, and the engines can move only on the Abt rack sections. There are two cog wheel axles, each worked by a separate pair of cylinders and not coupled together, the object being to ensure that each cog wheel performs its share of the work in

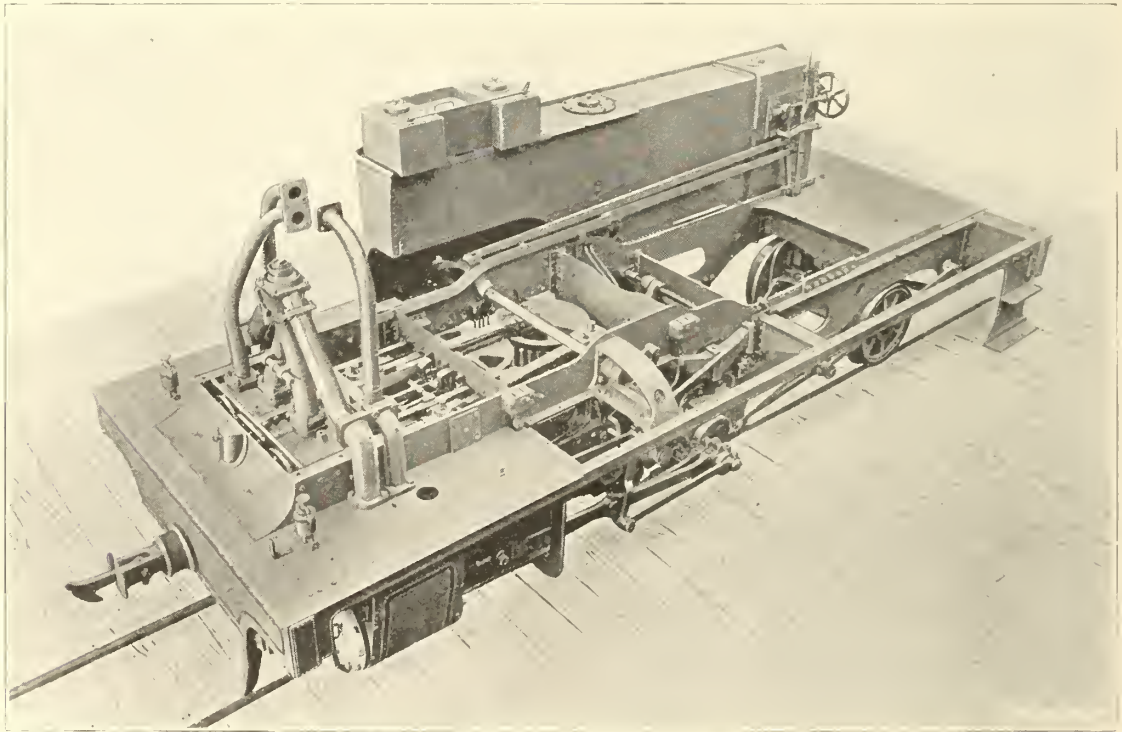

FIG. 402—FRAME, MOTION AND GEARING OF FELL'S CENTRAL RAIL SYSTEM ENGINE. BY NEILSON & CO., FOR NEW ZEALAND, 1886

actuated the disc wheels, which were horizontal, and loaded by compressed springs. The disc wheels grip the sides of a double-headed central rail, also laid horizontally. The motion and gearing are shown by Fig. 402. The gear wheels seen under the crank discs are for coupling together the right and left-hand inside vertical

spite of track inequalities. The cog axles revolve in bearings in specially designed frames, the latter being fixed to the axle-boxes of the carrier axles. By these means two-thirds of the weight of the engine, which rests on bearing springs on the carrier frame axle-boxes, is utilised to prevent upward thrust of the cog wheels. Each cog axle

is driven by connecting-rods and fly cranks outside the frames. Only two sets of Walschaerts valve gear are used for the four cylinders.

The same firm has also built combined rack and adhesion engines for the Nilgiri section of the South Indian Railway and for the Japanese Government Railways.² They are of the 2-6-0 and 2-6-2 types, with outside adhesion cylinders, 15½ in. by 20 in., driving six-coupled 3 ft. wheels, and inside rack cylinders, 11¾ in. by 16 in., driving an upper pinion which gears with two lower cog wheels, the centres of which are placed between the first and second coupled axles. Boiler pressure 180 lb.

Some 0-8-2 combined rack and adhesion engines were built for the South Indian Railway, by the North British Locomotive Company, 1911. The outside adhesion cylinders, 16½ in. by 16 in., drive 2 ft. 6 in. wheels, and the inside rack cylinders, 16½ in. by 14¼ in., drive a pinion gearing with two rack rail cog wheels. The heating surface is 1100

The Kitson-Meyer rack engines have been mentioned previously. All the above British-built rack engines are for the 3 ft. 6 in. and metre gauges.

Other Engines Built for Overseas.—It had been the writer's intention to deal with other engines built by the private locomotive builders for overseas of types which do not appear in British practice, but space will not permit of mention of more than one or two of them. The first 2-6-2 tender engines built in this country were made by Nasmyth, Wilson and Co. in 1885, for the New Zealand Government Railway (3 ft. 6 in. gauge). They have plate frames, 15 in. by 20 in. cylinders, 4 ft. 1½ in. coupled wheels, and total wheel base 23 ft. Other and later New Zealand engines of the 4-6-0 and 4-8-0 types by Sharp, Stewart, 1899, were illustrated in *The Engineer*, Nov. 9th, 1900.

An American type bar-framed 2-6-0 engine was designed and built in 1890 by the Vulcan Foundry for the Chilean Government Railways. The coupled wheels are 4 ft. 9 in. diameter and the

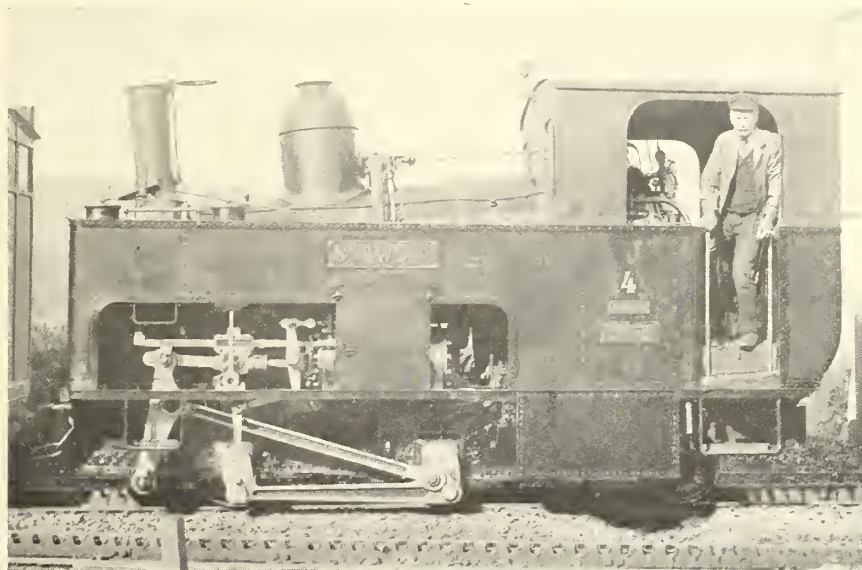

FIG. 403—RACK LOCOMOTIVE, SNOWDON MOUNTAIN RLY., 1896

square feet; grate area, 21½ square feet; pressure, 180 lb.; and total weight in working order, 49.6 tons, of which the coupled wheels carry 39.6 tons.

Two combined rack and adhesion engines of the 4-6-4 type were built by the Vulcan Foundry, 1904, for the Central South African Railways. All four cylinders are 18 in. by 20 in.; the outside pair driving the adhesion wheels, 3 ft. 6¼ in. diameter. The rack wheels, 3 ft. 0¾ in. diameter, are driven by the inside cylinders. The bogie wheel base is 6 ft. 4 in. at each end; coupled base, 8 ft. 3 in. + 4 ft. 6 in.; and the total base, 33 ft. 7 in. The rack pinions are placed between the first pair of coupled wheels. The heating surface is 1576.8 square feet; pressure, 200 lb.; and total weight in working order 88 tons.

² A diagram of the latter, which were built in 1895-98, was given in *THE ENGINEER*, March 26th, 1897.

cylinders 17 in. by 24 in. A considerable number of engines with bar frames have been designed and built in this country for overseas, but no bar frames have been used on British railways since Bury's type disappeared, except in the case of the imported American engines of 1899-1900.

Some compound side tank engines on Webb's three-cylinder system were built in 1884 by R. Stephenson and Co. for the Antofagasta Railway, Chile (2 ft. 6 in. gauge). These 4-2-4-2 engines were unique both in type and design. The outside high-pressure cylinders, 10 in. by 20 in., drove the hind coupled axle, the bearings of which were outside. The inside low-pressure cylinder, 20 in. by 18 in., drove the front uncoupled driving axle which had inside bearings. The driving wheels were 3 ft. diameter. The fixed wheel base was 8 ft., and the total base 26 ft. 1½ in.

Chapter XXII--1901-14

FROM 1901 onwards a very large number of illustrations and working drawings of engines built for British railways have appeared in the engineering Press, and as most of them are available for reference, it is not necessary to repeat in great detail information already given. The illustrations which follow are intended to fill up the gaps, and the tables will give the principal dimensions of leading classes of engines.

The chief developments during this period consisted of the revival and greatly extended use of locomotives with three and four high-pressure cylinders, the introduction in 1906 of high temperature superheating, and to some extent a revival of feed-water heating. Piston valves replaced slide valves, this change being accelerated by the use of superheaters. Slide valves remained in use for the smaller goods and shunting engines. The employment of large heavy tank engines for express trains extended on a number of leading railways.

For express goods trains several railways adopted the 2-6-0 and 4-6-0 types, though the 0-6-0 type is still built in large numbers. The use of eight-coupled engines of the 0-8-0 and 2-8-0 types has very greatly extended.

In regard to boilers, the Belpaire fire-box gradually spread to most of the leading main lines, with the chief exceptions of the Great Northern, North-Eastern and Caledonian amongst the large companies. The first-named line adhered rigidly to the round-topped direct-stayed fire-box casing, and although the North-Eastern built a few engines with Belpaire fire-boxes, the round-topped girder-stayed fire-box has prevailed.

Compound Locomotives: Three Cylinders.—In 1901-3 S. W. Johnson, of the Midland Railway, built five 4-4-0 engines at Derby on W. M. Smith's system. A single high-pressure cylinder, 19in. by 26in., is placed inside with piston valve below, and there are two low-pressure outside cylinders, 21in. by 26in., with vertical unbalanced slide valves inside the frames. The cylinder ratio is 1:2.45, and the boiler pressure in these five engines is 195 lb. The outside cranks are placed at 90 deg., and the middle inside crank at 135 deg. with the other two. All three cylinders drive the same axle, and three sets of Stephenson's gear with six excentrics on this axle are used. The exhaust from the high-pressure cylinder passes directly into a large steam chest common to the two low-pressure cylinders, thus eliminating the necessity for a receiver pipe.

These first five engines had independent high-pressure and low-pressure reversing gears, but the later Deeley engines had but a single reversing gear.

The engines can be worked as simple, semi-compound, or compound. Compound working is usual when running, and the whole of the exhaust from the high-pressure cylinder then passes into the two low-pressure cylinders. The pressure in the low-pressure steam chest varies from 40 lb. to 60 lb. per square inch, according to the high-pressure cut-off.

When starting, boiler steam at full pressure enters the high-pressure steam chest directly, and also the low-pressure steam chest through a reducing valve controlled by a spring-loaded regulating valve, which the driver can adjust from the cab to vary the pressure in the low-pressure steam chest; this pressure is shown by a gauge. The reducing valve is designed so that when the maximum pressure allowed in the low-pressure steam chest is reached, the boiler steam is automatically cut off.

Non-return valves are provided so that steam can pass from the low-pressure steam chest into either end of the high-pressure cylinder.

When starting, if the high-pressure piston valve is in such a position that the high-pressure steam ports are closed, the non-return valves lift, owing to the greater pressure below, and steam is admitted to either side of the high-pressure piston from the low-pressure steam chest. When the high-pressure steam ports open, the non-return valves are closed by the pressure in the high-pressure cylinder, which exceeds that in the low-pressure steam chest. The engine starts with 160 lb. in the low-pressure and a small differential pressure in the high-pressure cylinders.

Working as a simple engine was usually confined to starting, but could be used when running, in case of emergency, by altering the controlling valve spring to allow boiler steam at full pressure to enter both high-pressure and low-pressure steam chests, the high-pressure piston working in equilibrium. With a heavy train or on a severe gradient, the engine could be worked as a semi-compound, with a maximum pressure in the low-pressure steam chest of about 150 lb. to 160 lb., as determined by the driver turning a wheel and altering the spring-controlling valve. The admission of this extra boiler steam increased the power developed in the low-pressure cylinders. But ordinarily, when working compound, the reducing valve was set by the driver to 50 lb. to 60 lb. per square inch pressure in the low-pressure steam chests.

These engines¹ have 7ft. coupled wheels, and have since been rebuilt and modified to the

¹ An external elevation was given in THE ENGINEER, March 25th, 1904, and in THE LOCOMOTIVE MAGAZINE, December 5th, 1903.

Deeley arrangement. In the latter, first built in 1905, the Smith reducing and regulating valves were abandoned, and the auxiliary high-pressure steam to the low-pressure steam chest is admitted through an additional

low-pressure chest. To change over from compound to semi-compound, when running, the regulator has to be completely closed and then re-opened to the auxiliary steam position. The Deeley regulator simplifies the engine, but does

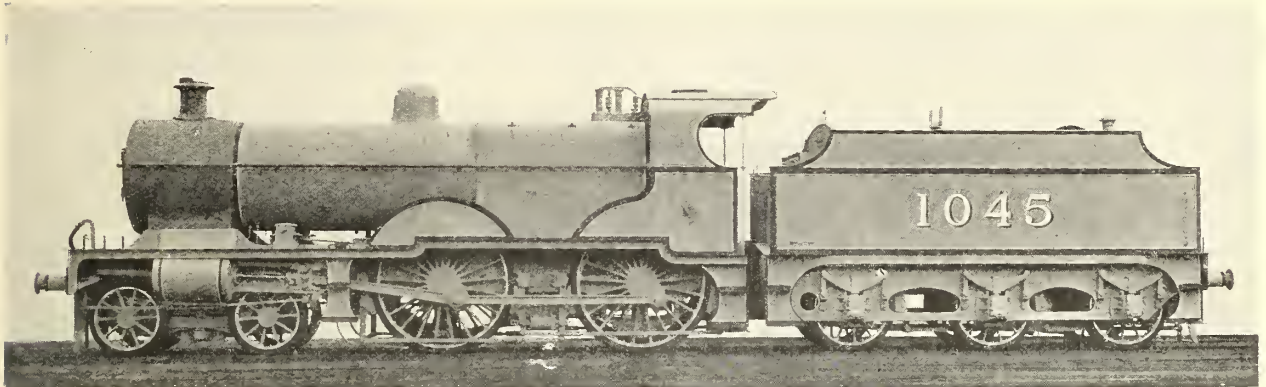

FIG. 404—SIR HENRY FOWLER'S THREE-CYLINDER COMPOUND EXPRESS ENGINE, MIDLAND RLY., 1924.

chamber and port in the regulator, which has a pipe connection to the low-pressure receiver. The cylinder arrangement with non-return valves remains as before, though there are differences in the details of the latter. When the regulator handle is moved through a small angle of about 20 deg., the additional port is opened and boiler steam is admitted to the low-pressure steam chest. At the same time the pilot valve opens a small port admitting steam to the high-pressure steam chest. These engines worked at 220 lb. boiler pressure.

When the regulator handle is pushed further over, the auxiliary steam to the low-pressure steam chest is cut off by the slide, but the main ports to the high-pressure steam chest are opened, and

not allow of the varied adjustment possible with the Smith reducing valve, when hill climbing.²

In the first Deeley Midland engines the 19in. high-pressure and 21in. low-pressure cylinders by 26in. stroke and 7ft. coupled wheels are as in the five Johnson compounds. They have done most excellent work, and may fairly be described as the best compound engines in this country. The type has been adopted by the L.M.S. Railway, for which forty more were built at Derby in 1924,—Fig. 404—and 100 more have since been delivered. The 1924 engines have 6ft. 9in. wheels, with high-pressure cylinder 19 $\frac{3}{4}$ in. and low-pressure 21 $\frac{3}{4}$ in. diameter by 26in. stroke; but the cylinders are now being lined up to 19in. and 21in., as in the earlier engines, and fitted with

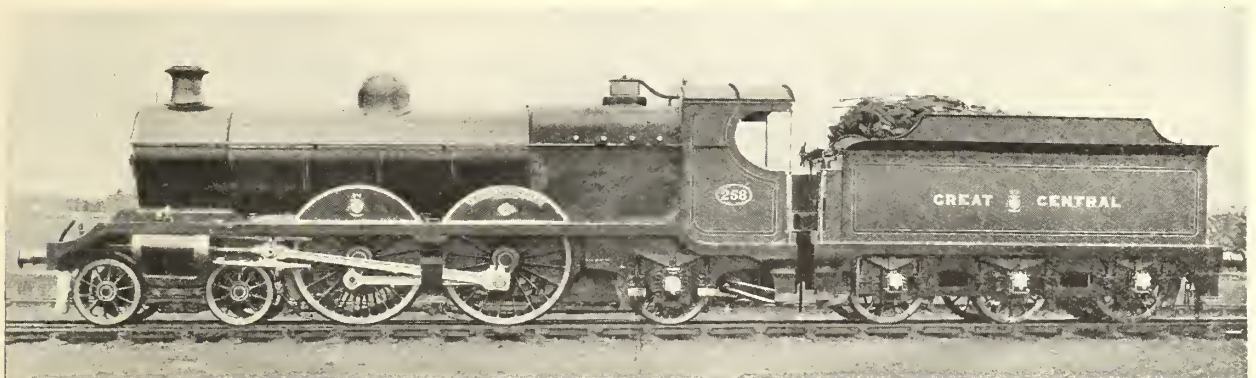

FIG. 405—J. G. ROBINSON'S THREE-CYLINDER COMPOUND EXPRESS LOCOMOTIVE, GREAT CENTRAL RLY., 1905

the engine works as a compound. In "semi-compound" working, the regulator is in a similar position to when starting, but as the speed is considerable there is a large pressure drop in the small pipe which connects the auxiliary port to the

Schmidt superheaters. Working pressure 200 lb. The other dimensions are similar to those of the earlier engines as superheated by Sir H. Fowler.

² Working drawings were given in THE ENGINEER, March 9th, 1906.

On the G.C.R., Mr. J. G. Robinson designed and built at Gorton in 1905-6 four three-cylinder Smith 4-4-2 compound engines, in which the drive was divided. Fig. 405 shows No. 258, the first of the series. The outside low-pressure cylinders, 21in. by 26in., drove the hind coupled axle, and the inside high-pressure cylinder, 19in. by 26in., the front coupled axle. The driving wheels were 6ft. 9in. diameter, and the working pressure 200 lb. per square inch. Stephenson valve gear was used.

The boilers of the G.C. compounds originally contained 221 tubes, the heating surface of which was 1778 sq. ft., making with that of the fire-box 153 sq. ft., a total of 1931 sq. ft.; the grate area was 26 sq. ft. Each weighed 71 tons, including 37 tons available for adhesion, 17 tons on the bogie, and a like weight on the trailing wheels. These engines are now fitted with superheaters.³

Compound Engines with Four Cylinders.—On the L. and N.W.R. in 1901 F. W. Webb designed 0-8-0 mineral engines—Fig. 406—with two outside

almost all of the class have been similarly rebuilt with larger boilers and 180 lb. pressure; and by the end of 1925 very few remained as compounds.

Webb's four-cylinder compound 4-4-0 express engines of 1901-3, the "1941," or "Alfred the Great" class, were similar to the earlier "Jubilee" class of 1897 but were fitted with larger boilers, and high-pressure cylinders increased from 15in. to 16in. diameter to enable the engines to start better. As the inside low-pressure cylinders remained 20½in. diameter, the cylinder ratio was reduced to about 1 : 1.63 only. This proved unsuitable, and in 1902 the high-pressure cylinders had to be reduced to 15in. diameter. Even with the increased ratio of 1 : 1.86 the work done in the high-pressure cylinders was a very large percentage less than that done in the low-pressure cylinders; moreover, there was only one valve gear for both high-pressure and low-pressure cylinders. In 1903-4 G. Whale altered the forty engines of this class by providing an additional outside Joy valve gear for the high-pressure cylinders.⁴

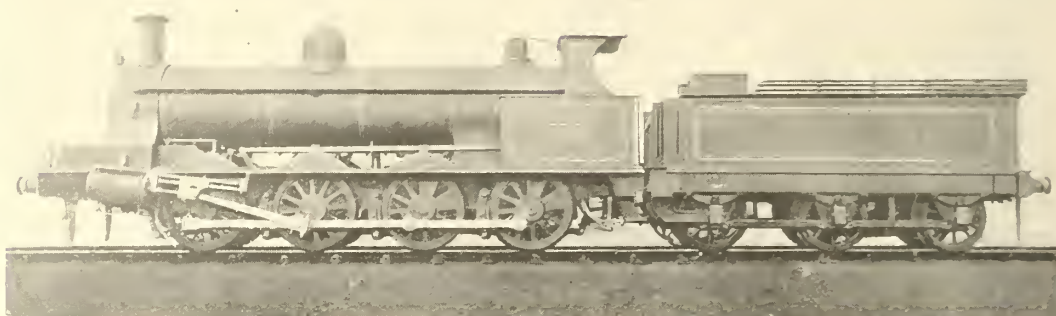

FIG. 406—F. W. WEBB'S FOUR-CYLINDER COMPOUND MINERAL ENGINE, LONDON & NORTH-WESTERN RLY., 1901

high-pressure cylinders 16in. by 24in. and two inside low-pressure cylinders 20½in. by 24in. in line beneath the smoke-box, all driving the second axle. The driving wheels were 4ft. 5½in. diameter, and the pressure 200 lb. Fire-box heating surface, 123 square feet; total heating surface, 1753 square feet; weight in working order, 53½ tons. The cylinders and motion were similar to those in the four-cylinder compound express engines. There was a concentration of weight at the front end, and G. Whale modified 36 of the class by adding a pony truck. But as compounds they left much to be desired, and in 1908 Mr. Whale converted a number by removing the high-pressure cylinders, retaining the inside 20½in. cylinders, and reducing the pressure from 200 lb. to 165 lb. As thus altered C. Bowen Cooke stated that they could haul five more loaded coal wagons from Colwick to Willesden, whilst the coal consumption was increased by only 1.2 lb. per mile. Since then

Subsequently G. Whale converted a "Jubilee" to a simple engine with 18½in. by 24in. cylinders, and testing it against one of the compounds found that it could deal with express trains with which the latter could not keep time. Since then nearly all Webb's 4-4-0 compounds have been similarly converted. C. Bowen Cooke stated that the wear and tear of the L. and N.W.R. compounds was very much greater, and that it was impossible to obtain the mileage between repairs that could be obtained from the simple engines.

Webb's last four-cylinder compounds of 1903-5 consisted of thirty 4-6-0 express goods engines. They were generally similar to the 0-8-0 coal engines, except that a leading four-wheeled radial truck replaced the first coupled axle of the latter, and the diameter of the coupled wheels was increased to 5ft. 3in. All four cylinders, which were somewhat steeply inclined, drove the front coupled axle. These engines were never satisfac-

³ Full particulars of these engines were given in *THE LOCOMOTIVE* of November 14th and December 15th, 1925.

⁴ Particulars of this alteration, with indicator diagrams, appeared in *THE ENGINEER*, January 8th, 1904.

tory, and Mr. Bowen Cooke broke them up after ten to fifteen years' service.

In 1903-5 the G.W.R. purchased three four-cylinder 4-4-2 compound express engines of the De Glehn type from the Société Alsacienne. The first engine, "La France," is shown by Fig. 407, and was similar to the "Atlantic" engines on the Ch. de fer du Nord with 6ft. 8½in. coupled wheels, high-pressure cylinders 13⅜in. by 25⅜in., and low-pressure cylinders 22⅛in. by 25⅜in. The boiler, which contained 126 ribbed Serve tubes, had a total heating surface of 2325 square feet, of which the fire-box provided 167 square feet; pressure 228 lb. The tube surface was estimated on the "fire" side. The two later engines were of the larger Paris-Orleans type, with 6ft. 8½in. coupled wheels, cylinders 14⅜in. and 23⅝in. by 25⅜in., and total heating surface 2616.8 square feet. Although these engines have done excellent

could be worked either simple or compound by means of a change valve placed over the low-pressure steam chest, and actuated by a small auxiliary steam cylinder under the control of the driver. Two lever reversing gears on the foot-plate could be operated either independently or together.

Engine 1421 (Doncaster, 1907) is illustrated by Fig. 408, and was similar in principle, but differed in that the low-pressure cylinders were 18in. by 26in., and their valves were actuated by inside Walschaerts gear. The recessing of the smoke-box inside the barrel reduced the tube heating surface. The crank axle was of a special built-up type, patented by Mr. Ivatt, in which the two webs of each crank were extended backwards, and shaped so that the extensions could be bolted together to form a balance weight.

Engine 1300 had certain features in common

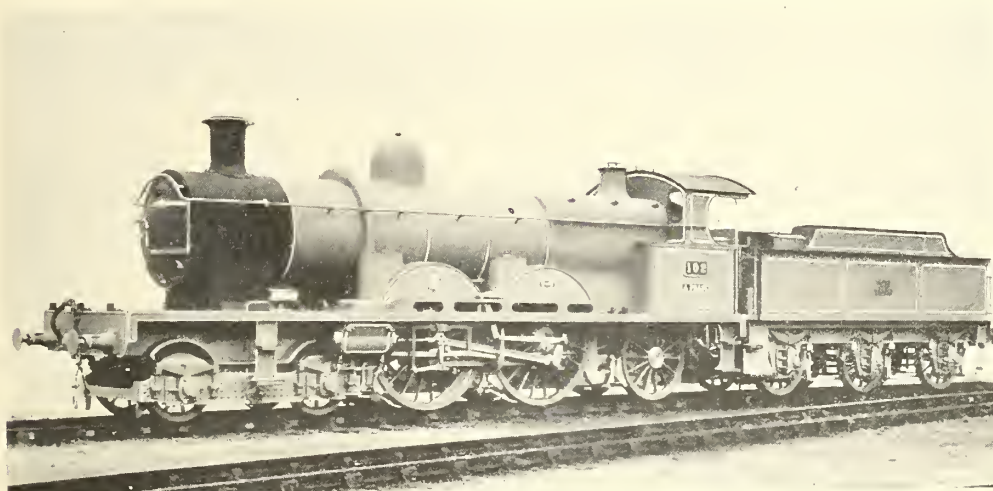

FIG. 407—DE GLEHN FOUR-CYLINDER COMPOUND LOCOMOTIVE, GREAT WESTERN RLY., 1903

work, the compound principle was not carried further, but the division of the drive between the two coupled axles was subsequently adopted for the G.W.R. four-cylinder simple engines.

In 1905-7 three four-cylinder compound 4-4-2 engines were built for the G.N.R., of which Nos. 292 and 1421 were of H. A. Ivatt's designs, and No. 1300 by the Vulcan Foundry was designed by the makers. Table XII on page 328 gives the dimensions of these engines, all of which were different. No. 292, built at Doncaster in 1905, had outside high-pressure cylinders, 13in. by 20in., and inside low-pressure cylinders, 16in. by 26in., in line under the smoke-box. The high-pressure cylinders drove the hind and the low-pressure the front coupled wheels. Both had balanced slide valves, those of the outside cylinders being placed above and driven by Walschaerts gear; those of the inside cylinders being between and driven by Stephenson link motion. A leading feature was that the engine

with the "de Glehn" type, in that the outside high-pressure cylinders, 14in. by 26in., were placed further back, and, as in the Doncaster engines, drove the hind coupled wheels—see Fig. 409. The inside low-pressure cylinders were 23in. by 26in. The latter had balanced slide valves, but the high-pressure cylinders had piston valves 6½in. diameter. Walschaerts valve gear was fitted. The Vulcan patented starting valve was provided. It admitted steam at reduced pressure to the receiver when starting, but automatically closed the passages immediately after the steam had reached the low-pressure cylinders, after which the engine worked compound. The Vulcan patented reversing gear was arranged so that one reversing screw operated both high-pressure and low-pressure valve gears simultaneously, with a differential cut-off in the two. In addition, the two gears could be controlled independently. The boiler differed from those of the Doncaster engines in having a long fire-box between the frames

instead of the short wide fire-boxes of Ivatt's design, and in being provided with Serve tubes.⁵ Other details, with an account of working trials, will be found in "Proc." Inst. Mech. Eng., May, 1907.

cylinder simple engine has become standard. These two compound engines have since been superheated.⁶

In 1907 Mr. G. Hughes designed a four-cylinder 0-8-0 compound mineral engine for the L. and

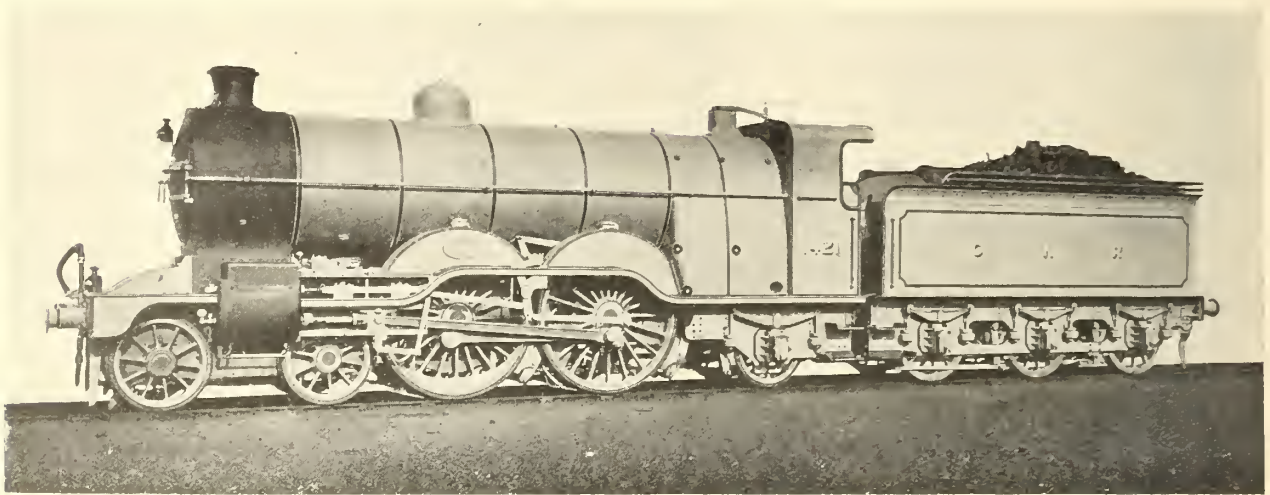

FIG. 408—II. A. IVATT'S FOUR-CYLINDER COMPOUND EXPRESS ENGINE, GREAT NORTHERN RLY., 1907

In 1906 two 4-4-2 four-cylinder express engines were built at Gateshead Works of the N.E.R. to W. M. Smith's design under W. Worsdell's supervision—Fig. 410. They have two outside high-pressure cylinders, 14½ in. by 26 in., and two inside low-pressure cylinders, 22 in. by 26 in., all four driving the front coupled axle. Piston valves driven by inside valve gear are used for all four cylinders, that for one engine being Stephenson's and for the other Walschaerts'.

Y.R., of which ten were built at Horwich, following the conversion in 1906 of one of the two-cylinder simple engines into a four-cylinder compound. The high-pressure cylinders, 15½ in. by 26 in., are outside and drive the third coupled axle, and the inside low-pressure cylinders, 22 in. by 26 in., drive the second. The high-pressure valves are of the piston type, with inside admission, Richardson balanced valves being used for the low-pressure cylinders. The inside valve gear is

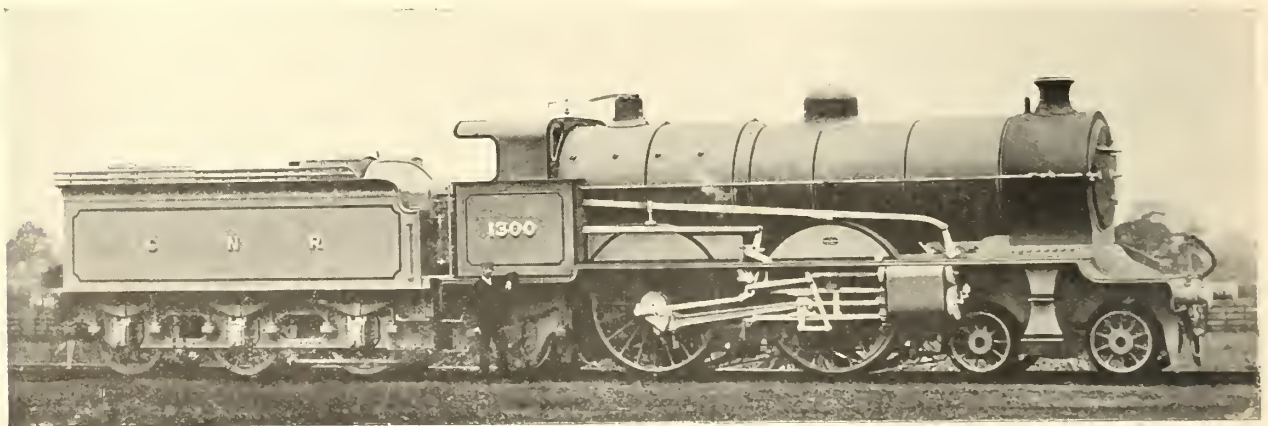

FIG. 409—VULCAN FOUNDRY FOUR-CYLINDER COMPOUND EXPRESS ENGINE, GREAT NORTHERN RLY., 1905

Though these engines have been very successful, they have not been repeated, and the three-

⁵ Particulars of this engine, and also of No. 292, were given in *THE ENGINEER* of January 26th, 1906, and May 19th, 1905, and in *THE LOCOMOTIVE*, January 15th, 1924.

Joy's, one set driving one high-pressure and one low-pressure valve by means of a rocking lever. An arrangement of special design admits boiler

⁶ Further particulars of these engines were given in *THE LOCOMOTIVE* of May 15th, 1925.

steam to the low-pressure steam chest for starting. This consists of two slide valves, back to back, placed in an auxiliary chamber within the low-pressure steam chest. This chamber receives boiler steam from the regulator pipe in the smoke-box, and the valve is moved by a rod connected to a lever forming part of the reversing shaft of the valve gear. When starting, the reversing lever is in full gear, and in that position boiler steam passes into the low-pressure steam chest, and through the receiver pipes to the back of the high-pressure pistons. As the front sides of these pistons are also receiving boiler steam, they are practically in equilibrium, and the engine starts with full boiler pressure on the 22in. low-pressure cylinders. This starting gear is beyond the control of the driver. The admission of high-pressure steam into the low-pressure steam chest ranges between the limits of full gear—83 per cent. front port, 88 $\frac{1}{4}$ per cent. back port—and about 73 per cent. cut-off. Full details of these engines with tests in service were given by Mr. Hughes in a

outside. All four drove the same axle, and the inside and outside cranks on the same side were at 180 deg. The coupling-rods were retained. At the same time Sandiford converted another engine into a two-cylinder compound, using a cock to admit boiler steam to the low-pressure cylinder for starting. The drawings for both engines were made in 1883 before the two-cylinder Worsdell system was tried here, and when only a few of Webb's earliest three-cylinder engines were at work. Full particulars of Sandiford's engines may be found in "Proc." Inst. Mech. Eng., August, 1886.

Unfortunately Sandiford's early trials do not appear to have been continued, for the glamour of Crewe prevailed, and ten of Webb's three-cylinder uncoupled compound passenger engines with 6ft. driving wheels and cylinders 12in. and 24in. diameter by 24in. stroke were sent out from this country to the Oudh and Rohilkhund State Railway in 1884.⁷ In the tabulated statement added to Mr. E. Worthington's paper on "Compound Locomotives" (I.C.E., 1888), the boiler pressure

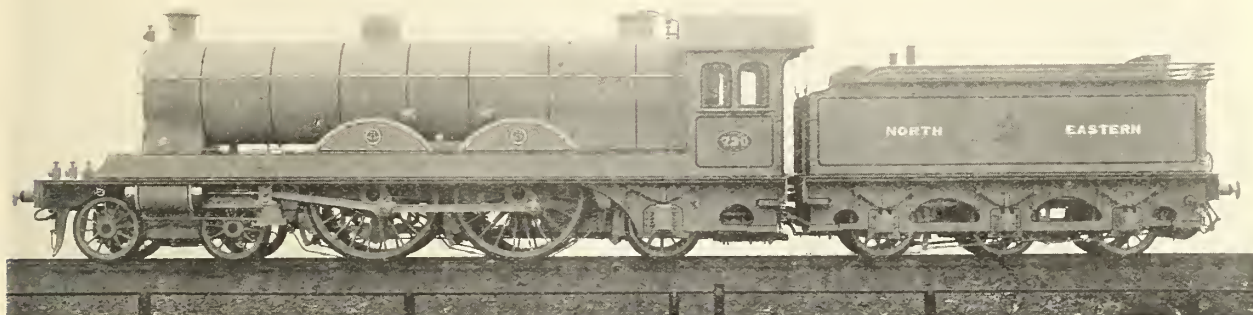

FIG. 410—W. WORSDELL'S FOUR-CYLINDER COMPOUND EXPRESS LOCOMOTIVE, NORTH-EASTERN RLY., 1906

paper before the Inst. Mech. Engineers, March, 1910.

These notes conclude the history of the compound locomotives in this country to the present day. Of the four-cylinder types, none have been perpetuated, and the only type which is still built is the Smith three-cylinder express engine with Deeley's modifications and the later addition of superheating, as in use on the L.M. & S. Railway. Of the three G.N.R. four-cylinder "Atlantics," two, Nos. 1300 and 1421, were reconstructed as two-cylinder simple engines.

Compound Locomotives in India.—Before leaving the subject of compound engines, it may be added that almost every type has been tried in India, and the four-cylinder balanced compound had its birth there and not in France. In 1884 Charles Sandiford, then locomotive superintendent of the North-Western State Railway, altered a mixed traffic 2-4-0 engine, replacing its 16in. by 24in. inside cylinders with 17in. cylinders and adding a pair of 11 $\frac{3}{4}$ in. by 24in. cylinders

of these engines was given as 120 lb. only. Possibly this may have been an error.

In 1887 the Worsdell two-cylinder system was tried on the Bengal-Nagpur Railway, when Neilson and Co. built one or two of the 4-6-0 I.S.R. "L" class as compounds. These had outside cylinders, 18in. and 26in. diameter by 24in. stroke, 4ft. 3in. coupled wheels, and 160 lb. pressure.⁸ Neilson and Co. also built 2-6-0 engines in 1892 for the Indian Midland Railway, with inside cylinders, 20 $\frac{1}{2}$ in. and 28in. diameter by 26in. stroke and 4ft. 6in. wheels. Similar engines for the East Coast Railway were altered by the Bengal-Nagpur Company to simple engines.

About 1893 one of the Webb type of engines on the Indian State Railways was converted to Mr. John Riekie's three-cylinder system by increasing the 12in. high-pressure cylinders to 16 $\frac{1}{2}$ in. diameter, and the inside low-pressure cylinder

⁷ Particulars and illustrations of these engines were given in THE LOCOMOTIVE for March 14th, 1925.

⁸ Drawings were given in THE ENGINEER, July 20th, 1888.

from 24in. to 26in. diameter. The drive was divided as before, but the wheels were coupled. Mr. Riekie stated that the boiler gained from the alteration, the blast was much softer, and the wear and tear were reduced. Subsequently, in 1900, a two-cylinder compound 2-6-0 engine was rebuilt by Mr. Riekie with two outside high-pressure cylinders, 20in. by 26in., and one inside low-pressure cylinder, 31½in. by 26in. The cylinder ratio was small, but the designer's idea was to cut off early in the high-pressure cylinders, and to that end a special arrangement was embodied by which after the engine had made one or two revolutions the reversing lever was automatically notched up to a maximum of 30 per cent. cut-off in the high-pressure cylinders. This cut-off could not be increased by the driver, though he could reduce it below 30 per cent.

Of four-cylinder engines there are in service on the Bengal-Nagpur Railway fifteen "de Glehn" 4-4-2 express engines, built since 1907 by the North British Locomotive Company. They have 6ft. 6in. coupled wheels, 13in. by 26in. high-pressure and 21½in. by 26in. low-pressure cylinders; fire-box heating surface, 153 square feet; total, 1845 square feet; grate area, 31.7 square feet; pressure, 220 lb.; total weight in working order, 72.2 tons, of which 34.5 tons are carried on the coupled wheels.

4-4-0 Non-compound Engines.—It is impossible to find space in which to describe all the principal classes of this, the standard British express engine. Table XIII on page 334 gives the leading dimensions of fifteen of the more noteworthy examples, of which most of those built from 1910 onwards were superheated. With the exception of the G.W.R. engines, Nos. 4 and 5 in Table XIII, all have inside cylinders and frames. The G.W.R. "City" class (4) have inside cylinders and double frames, and the "County" class (5) have outside cylinders with the extremely long stroke of 30in. The boilers of both classes are without domes and of the "wagon-top" type with Belpaire fire-boxes, this design being due to Mr. Churchward. The "City" class have steam reversing gear with steam and oil cylinders fixed inside the frames in an inclined position so that the piston-rod is directly connected to the lever arm of the reversing shaft. It was the "City of Truro" of this class which attained a speed of 102.3 miles per hour. The "City" class is shown by Fig. 411, and the "County" class by Fig. 412. The L. and S.W.R. engines (7) and (11) had Drummond's water-tube fire-boxes. The majority have Stephenson's link motion with the following exceptions:—The L. and N.W.R. engines, Nos. 6 and 10, have Joy's valve gear; inside Walschaerts gear is used in the L. and

TABLE XII.—Compound Engines 1901 to 1907.

Railway.	Type.	Cylinders.			Wheels.	Wheel base.
		H.P.	L.P.	Ratio.		
M.R., 2631 ...	4 4-0, 3-cyl. (Smith) ...	19"×26" (ins.)	21"×26" (outs.)	2.45	3' 6½", 7'	6' 6"+8' 3"+9' 6"
M.R., 1000 ...	4 4-0, 3-cyl. (Smith-Deeley) ...	19"×26" (ins.)	21"×26" (outs.)	2.45	3' 6½", 7'	6' 6"+8' 3"+9' 6"
G.C.R., 258 ...	4 4-2, 3-cyl. (Smith) ...	19"×26" (ins.)	21"×26" (outs.)	2.45	3' 6", 6' 9", 4' 3"	6' 6"+5' 9"+7' 3"+8' 3"
L. & N.W.R., 1941 ...	4 4-0, 4-cyl. (Webb) ...	16"×24" (outs.)	20½"×24" (ins.)	1.63†	3' 9", 7' 1"	6' 3"+7' 3"+9' 8"
G.N.R., 292 ...	4 4-2, 4-cyl. (Ivatt) ...	13"×20" (outs.)	16"×26" (ins.)	1.96	3' 8", 6' 8", 3' 8"	6' 3"+5' 3"+6' 10"+8'
G.N.R., 1421 ...	4 4-2, 4-cyl. (Ivatt) ...	13"×20" (outs.)	18"×26" (ins.)	2.49	3' 8", 6' 8", 3' 8"	6' 3"+5' 3"+6' 10"+8'
G.N.R., 1300 ...	4 4-2, 4-cyl. (Vulcan Foundry) ...	14"×26" (outs.)	23"×26" (ins.)	2.7	3' 2", 6' 8", 3' 8"	6' 3"+6' 9"+8' 6"+6' 9"
N.E.R., 730 ...	4 4-2, 4-cyl. (Smith) ...	14½"×26" (outs.)	22"×26" (ins.)	2.38	3' 7½", 7' 1½", 4'	6' 6"+7' 3"+7' 6"+7' 6"
L. & N.W.R., 1400 ...	4-6-0, 4-cyl. (Webb) ...	15"×24" (outs.)	20½"×24" (ins.)	1.87	3' 0", 5' 0"	6' 3"+6' 9"+5' 9"+5' 9"
L. & N.W.R., 1881 ...	0-8-0, 4-cyl. (Webb) ...	16"×24" (outs.)	20½"×24" (ins.)	1.87	4' 5½"	5' 9"+5' 9"+5' 9"
L. & Y.R., 1471 ...	0-8-0, 4-cyl. (Hughes) ...	15½"×26" (outs.)	22"×26" (ins.)	2.02	4' 6"	5' 11½"+5' 2¼"+5' 2¼"

TABLE XII—continued.

Railway.	Heating surface.			Super-heating surface.	Grate area.	Pressure.	Weight full.		Date.	Illustrated as below.
	Tubs.	Fire-box.	Total.				Adhesive.	Total.		
M.R., 2631 ...	sq. ft.	sq. ft.	sq. ft.	sq. ft.	sq. ft.	lb. per sq. in.	tons.	tons.		
M.R., 1000 ...	1569.8	150	1719.8	—	26	195	38.875	59.525	1901	
Do., superheated	1320	151	1473	—	28.4	220	39.1	59.9	1905	
G.C.R., 258 ...	1170*	151	1321	360	28.4	200	39.2	61.7		
L. & N.W.R., 1941 ...	1778	133	1931	—	26	200	37	71	1905	Fig. 405
G.N.R., 292 ...	1328.5	179.25†	1507.7	—	20.5	200	37	57.6	1901	
G.N.R., 1421 ...	2359	141	2500	—	31	200	36	68.5	1905	
G.N.R., 1300 ...	2208	143.6	2351.6	—	31	200	36	69.1	1907	Fig. 408
G.N.R., 730 ...	2344‡	170	2514	—	31	200	37	71	1905	Fig. 409
N.E.R., 730 ...	1916	180	2096	—	29	225	39.15	75.6	1906	Fig. 410
L. & N.W.R., 1400 ...	1630	123	1753	—	20.5	200	44	60	1903	
L. & N.W.R., 1881 ...	1630	123	1753	—	20.5	200	53.5	53.5	1901	Fig. 406
L. & Y.R., 1471 ...	1767	147	1914	—	23.05	180	60.8	60.8	1907	

* The Midland engines have been superheated by Sir H. Fowler in accordance with the dimensions shown. † The L. and N.W.R. engines had high-pressure cylinders subsequently reduced to 15in. diameter. The fire-box heating surface includes that of the water bottom. The pressure was subsequently reduced to 175 lb. ‡ The G.N.R. No. 1300 had Serve tubes. Heating surface estimated on internal surface.

S.W.R. engine (11), by D. Drummond, and in the G. and S.W.R. engine (14), by P. Drummond. The Midland engines (8) have Deeley's valve gear, as illustrated in *The Engineer* of September 20th, 1907. The principle of this gear is similar

The heavy load, 42 tons, on the two driving axles of the North-Eastern engine (9) may be noted. This, the writer believes, is the maximum in this country.

The Great Eastern engines of the "1900" class,

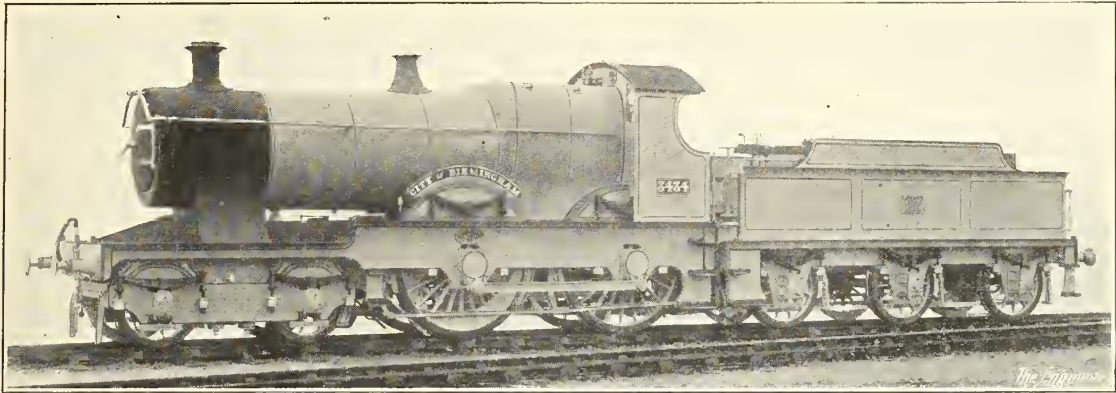

FIG. 411—W. DEAN'S "CITY" CLASS LOCOMOTIVE, GREAT WESTERN RLY., 1903

to that of the Belgian Stévant gear, though Deeley's gear was independently designed. The crosshead connection for the lap and lead movement is like that of the Walschaerts gear, but the oscillation of the expansion link, instead of being produced by an eccentric, is derived from the crosshead on the opposite side of the engine. When the die block in one link is at the top that in the other is at the bottom. Another peculiarity is that the cylinder centres are spaced 2ft. apart, but the driving crank pins are 1ft. 11½ in. between centres. The small ends of the connecting-rods are provided with gudgeon pins having ball and socket joints. When new the engines carried 220 lb. pressure, but this was subsequently reduced to 200 lb. They have also been provided with

No. 1 in Table XIII, by Jas. Holden, are illustrated by Fig. 413. They were larger than any of their predecessors on the G.E.R., and have done excellent work, often of a very exacting character. The first engine of the class, named "Claud Hamilton" in honour of the chairman of the Company, was shown at the Paris Exhibition of 1900. The original engines of this class had boilers with 1630 square feet of heating surface, and weighed 50 tons 8½ cwt., but a later series were provided with Belpaire fire-boxes, and had 1706 square feet of heating surface, and weighed 51 tons 14 cwt.

The Great Central engines (13) by Mr. J. G. Robinson, amongst the most successful of the 4-4-0 type in the country, are representative of the best

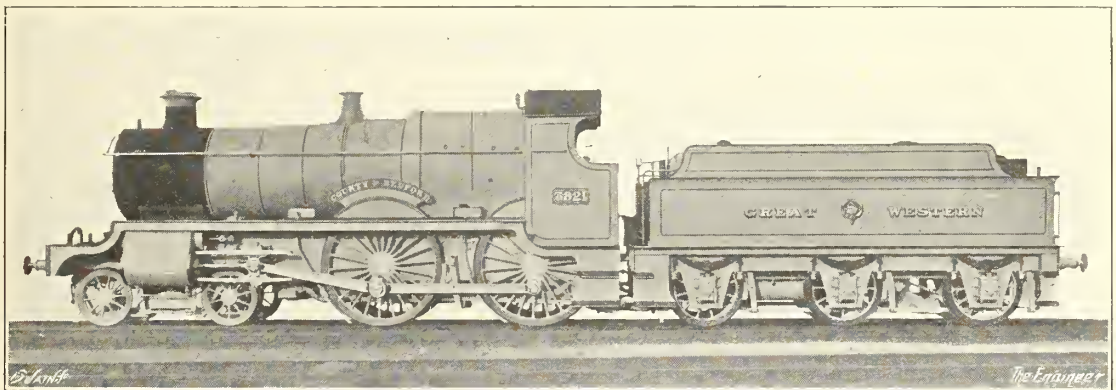

FIG. 412—G. J. CHURCHWARD'S "COUNTY" CLASS LOCOMOTIVE, GREAT WESTERN RLY., 1904-11

superheaters, resulting in a modification of the heating surface, of which the tubes give 1170 square feet and the fire-box 151 square feet; total, 1321 square feet. Additional superheating surface, 360 square feet.

modern British practice. They largely superseded the 4-4-2 type on the G.C.R., and twenty-four more have recently been built for the L. and N.E.R. One of them is illustrated by Fig. 414.

In Table XIII the dimensions given are those of

the engines as originally built. Most of the earlier engines of 1900-1907 have since been rebuilt with larger boilers and superheaters, and in several cases piston valves have been substituted for the original slide valves. The L. and S.W.R. engine

Nearly all the engines in the table have since been superheated, when the cylinders of the G.N.R. engines were increased to 20in. diameter, and those of the G.C.R. and N.B.R. engines to 21in. diameter. The L.B. and S.C.R. engines by

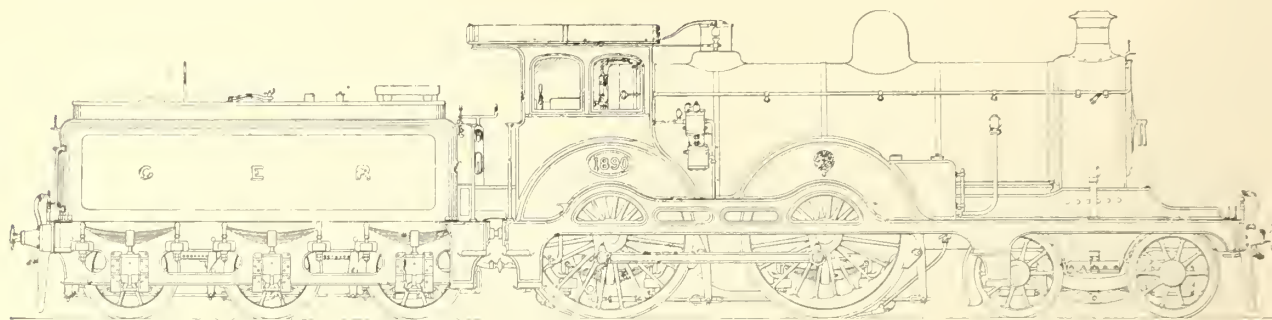

FIG. 413—JAS. HOLDEN'S EXPRESS LOCOMOTIVE, GREAT EASTERN RLY., 1900

(11) and the G. and S.W.R. engine (14) were fitted with D. Drummond's smoke-box steam dryer, which superheated the steam about 20 deg. Fah. only.

As mentioned previously, Mr. Bowen Cooke's 6ft. 9in. 4-4-0 engine of 1910, known as the "George the Fifth" class (No. 10 in Table XIII), had Joy's valve gear, and in other respects closely followed the practice of his predecessor, Mr. George Whale, with the important difference that he adopted superheating and 20½in. by 26in. cylinders. Fig. 415 illustrates one of these engines.

4-4-2 Locomotives: Two Cylinders.—Table XIV on page 334 gives the leading dimensions of six classes. All have outside cylinders, which drive the hind coupled axle, and the trailing axles under the foot-plate have outside bearings. The only 4-4-2 engines in this country with inside bearings for the trailing wheels are the three French compounds on the G.W.R. The G.N.R. and L.B. and S.C.R. engines have wide fire-boxes extending laterally over the back of the main frames. The illustration

Mr. D. Earle Marsh were built in 1911 with superheaters, and are a later improvement on his earlier "Atlantics" of 1905.⁹ In the later engines the cylinders are cast with a saddle, in which the smoke-box rests.

Mr. Wilson Worsdell brought out the first of his "Atlantic" type express engines (Class V) in 1903—Engine No. 532. Two noticeable improvements in these engines were the longer stroke and enlarged boiler barrel (5ft. 6in.). The second of the class, No. 649, came out in January, 1904, and is illustrated by Fig. 417.

In 1905 Mr. Churchward built a number of 4-4-2 engines at Swindon with 6ft. 8½in. wheels, 18in. by 30in. cylinders, and 225 lb. pressure. These engines were built to institute a comparison with the French compound "Atlantics." The adhesive weight of a non-compound "Atlantic" was insufficient for such a high boiler pressure, and subsequently the engines were altered to the standard 4-6-0 type. There were several American features in the design, notably the cylinder saddles, and the compensating levers, which

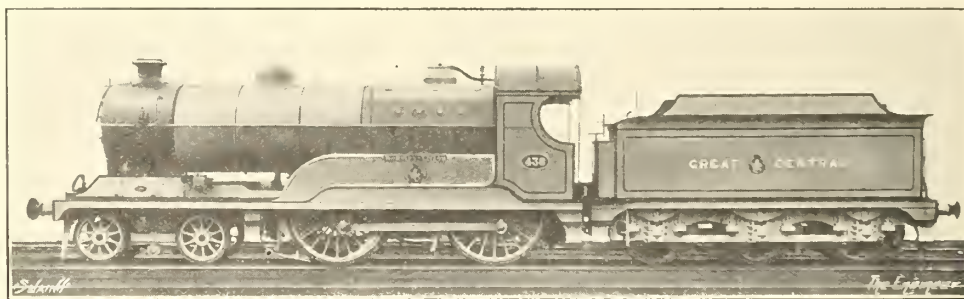

FIG. 414—J. G. ROBINSON'S "DIRECTOR" CLASS LOCOMOTIVE, GREAT CENTRAL RLY., 1913

—Fig. 416—which is representative of the type with narrow fire-box, shows one of the N.B.R. engines by R. Stephenson and Co. The North British Locomotive Company also built a number of these engines.

grouped together the spring suspension of the four coupled and the small trailing wheels.

⁹ Described and illustrated in *THE ENGINEER*, February 23rd, 1906, and April 1st, 1907; and in *THE LOCOMOTIVE MAGAZINE*, January 15th, 1906.

Of 4-4-2 engines with inside cylinders, in addition to the forty on the L. and Y.R., previously described, there is one on the G.N.R. of H. A. Ivatt's design. It was originally built in 1902 as a four-cylinder engine, but was reconstructed in 1911 as a two (inside) cylinder type,

second coupled axle, and Nos. 4 to 7 have inside cylinders driving the first coupled axle. With the exception of the L. and N.W.R. engine (5), which has Joy's valve gear, all have Stephenson's link motion. Round-topped fire-box casings are used only in engines (4) and (5) for the Caledonian

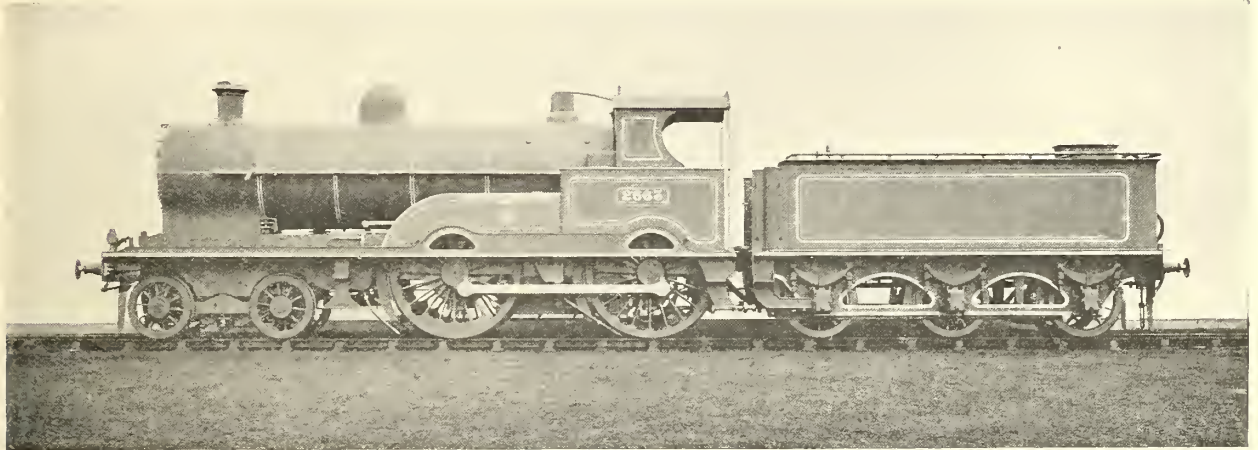

FIG. 415—C. J. BOWEN COOKE'S EXPRESS ENGINE, LONDON & NORTH-WESTERN RLY., 1910

with 18½ in. by 26 in. cylinders, 6 ft. 7½ in. coupled wheels, and 170 lb. pressure. The new boiler has a tube heating surface of 1027.5 square feet; fire-box, 135.5 square feet; and superheating surface, 254 square feet; weight in working order, 58 tons 13 cwt., of which 33 tons 8 cwt. are available for adhesion.

4-6-0 Express Engines: Two-cylinder Type.—Following the introduction of 4-6-0 engines on the N.E.R., in 1899-1901, the G.W.R. built experimental engines in 1902-3, and on this line since 1905 the type has gradually superseded the four-coupled engine for the fastest and heaviest main line expresses. Other railways followed suit, though in no other case has the six-coupled so

and L. and N.W. railways respectively; other engines have Belpaire fire-boxes. Most of these engines have been illustrated in the engineering journals. Fig. 418 shows J. Manson's earlier type of 1903¹⁰ built by the North British Locomotive Co. The later superheated design of 1911, of which dimensions are given in the table, was derived from it. The L. and N.W.R. engines (5), "Prince of Wales" class, are similar in appearance to the non-superheated "Experiment" class—*The Engineer*, October 6th, 1905, and illustrated in *The Locomotive*, June 15th, 1905—by G. Whale, but have extended smoke-boxes and cylinders 20½ in. instead of 19 in. diameter, and the piston valves are driven by rocking shafts.

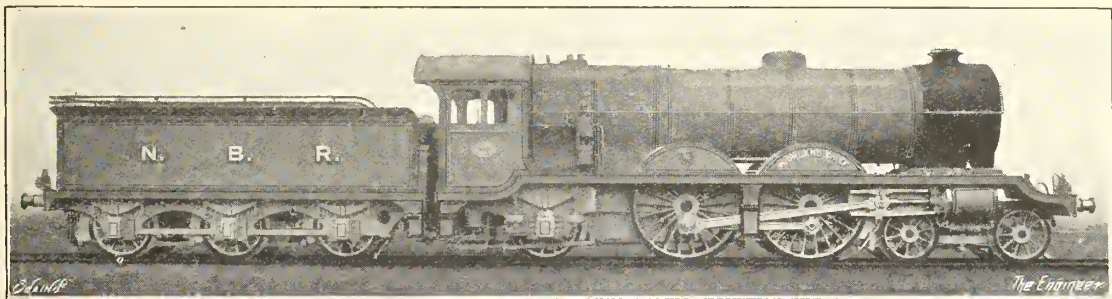

FIG. 416—W. P. REID'S "ATLANTIC" TYPE LOCOMOTIVE, NORTH BRITISH RLY. 1906-11

completely ousted the four-coupled engine; on the other hand, on the N.E.R. the "Atlantic" type has taken the place of the 4-6-0. Table XV shows the principal types, of which Nos. 1 to 3 are engines with two outside cylinders driving the

Table XV gives the dimensions of the earlier engines of the various classes. In later engines these were varied, as, for instance, in the G.W.R.

¹⁰ Described in *THE ENGINEER*, February 29th, 1905, and also in *THE LOCOMOTIVE*, November 15th, 1923.

"2900" class (1), which from 1911 onwards had 18½ in. by 30 in. cylinders and superheaters. Of the G.C.R. engines (2), all of which were built by Beyer, Peacock, the two first engines of 1903 had 6 ft. 9 in. wheels, but ten later engines of 1907 had 6 ft. 6 in. wheels.¹¹

As representative of the inside cylinder types the Great Eastern engine is illustrated by Fig. 419, the Great Central by Fig. 420, and the Caledonian by Fig. 421.

Locomotives with Four Cylinders.—In 1902 H. A. Ivatt built a 4-4-2 engine at Doncaster with four 15 in. by 20 in. cylinders which drove the front coupled axle. The coupled wheels were 6 ft. 7½ in. diameter, and the pressure 175 lb.¹² There was also one piston valve for the two cylinders on the same side. It was placed inside and driven by Stephenson's link motion. In 1904 new cylinders with independent valves were substituted, those for the outside being driven by Walschaerts gear. This engine was, as already mentioned, converted in 1911 to a two-cylinder engine.

The first of Mr. G. J. Churchward's G.W.R. four-cylinder engines of 1906 was of the 4-4-2

the arrangement of cylinders without long steam and exhaust pipes is simpler. In the L. and Y.R. engines (11) a compromise was made by placing the outside cylinders under the back of the smoke-box, and the inside cylinders forward beneath the front of the smoke-box. This simplified the pipe connections. D. Drummond on the L. and S.W.R. varied his 4-6-0 designs considerably. His first engines of 1905, like those of 1907—No. 9 in the table—had the outside cylinders placed behind the bogie, as in the de Glehn arrangement, the inside cylinders being underneath the smoke-box. The drive was divided. But in the "443" class (10), although the divided drive was retained, the four cylinders are in line under the smoke-box.

The valve gears of the six examples in the table are differently arranged. The G.W.R. engines (8) have inside Walschaerts gear, the valves of the outside cylinders being driven by horizontal rocking levers connecting the back end of the inside valve spindle with the front end of the outside one. Each lever is bent backwards from the fulcrum to the outside valve spindle connection



FIG. 417—W. WORSDELL'S "ATLANTIC" TYPE EXPRESS ENGINE, NORTHEASTERN RLY., 1904

type, with the drive divided between two coupled axles as in the French compounds.¹³ It was afterwards converted to the standard 4-6-0 type. All four-cylinder engines built for British railways since 1907, except one 4-4-0 engine on the Glasgow and South-Western Railway and one 0-10-0 banking engine on the Midland, are of the 4-6-0 type. The six principal classes to 1914 are given in Table XV on page 334. Of these, Nos. 8 to 11 have divided drive, but in the L. and N.W.R. engine No. 12, all four cylinders are in line under the smoke-box and drive the front coupled axle—Fig. 422. The latter method throws considerable stress on the driving axle, but

to correct the valve events of the inside and outside cylinders for the angularity of their connecting-rods.

The L. and S.W.R. engine (9) has independent gears for inside and outside cylinders, the former a Stephenson link motion and the latter Walschaerts. These engines are mostly used for fast goods traffic. The other L. and S.W.R. engine (10) has outside Walschaerts gear with straight rocking levers attached to the back ends of the outside valve spindles to work the inside valves. The L. and Y.R. engine (11), as built in 1908, had inside Joy's gear with a straight rocking lever attached to the crosshead of the inside valve spindle in order to drive the outside valves. These engines, which had balanced slide valves, have been reconstructed with piston valves, and outside Walschaerts gear. In modern engines of high power the connecting-rods with Joy's gear are overloaded. The L. and N.W.R. engine has outside Walschaerts gear, but the rocking levers

¹¹ A description of all the "Atlantic" type engines of the Great Central Railway appeared in *THE LOCOMOTIVE* for November 14th and December 15th, 1925.

¹² See *THE ENGINEER*, January 23rd, 1903, and *THE LOCOMOTIVE*, November 15th, 1923.

¹³ Drawings were given in *THE ENGINEER*, February 22nd, 1907, and in *THE LOCOMOTIVE MAGAZINE*, August 15th, 1906.

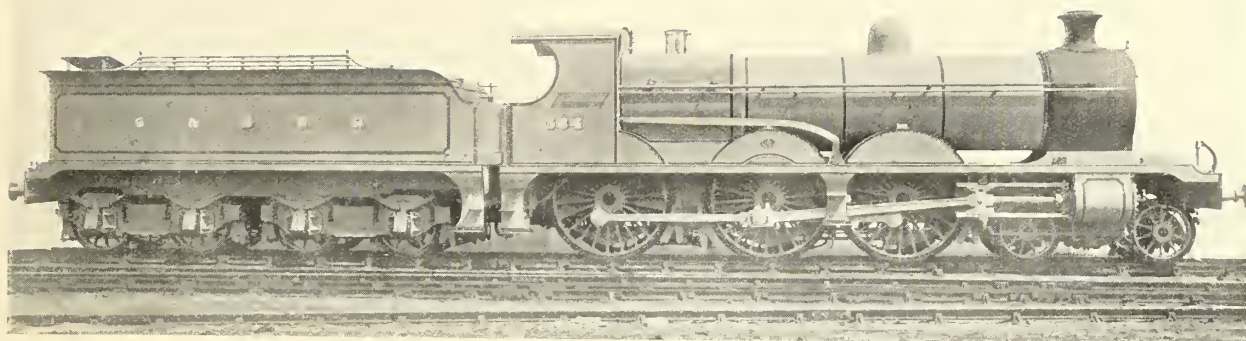

FIG. 418—J. MANSON'S 4-6-0 EXPRESS ENGINE, GLASGOW AND SOUTH-WESTERN RLY., 1903

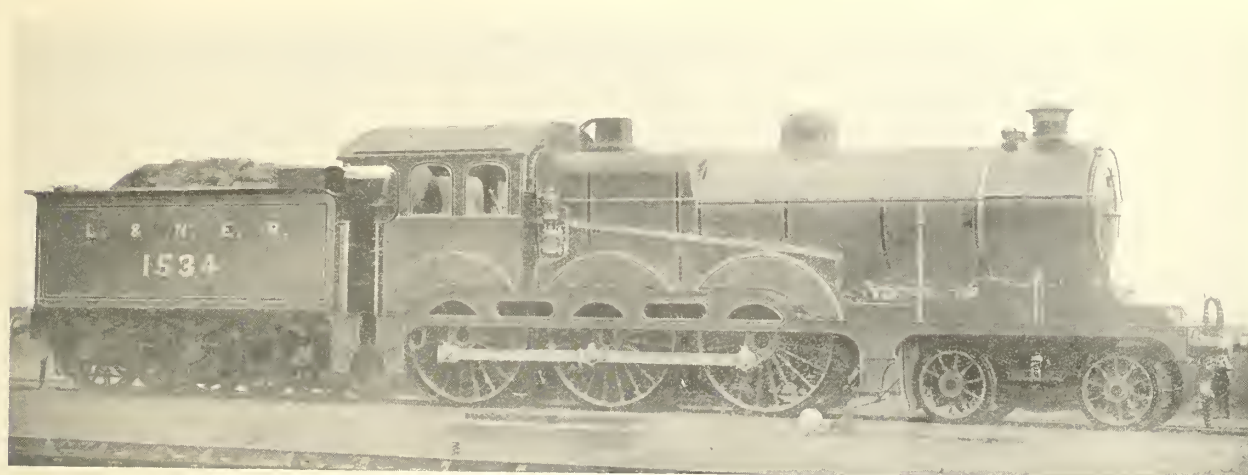

FIG. 419—S. D. HOLDEN'S 4-6-0 EXPRESS ENGINE, GREAT EASTERN RLY., 1911

[Photo. Locomotive



FIG. 420—J. G. ROBINSON'S 4-6-0 EXPRESS ENGINE, GREAT CENTRAL RLY., 1912

TABLE XIII.—4-4-0 Engines 1900 to 1914.

Railway and class.	Designer.	Date.	Cylinders.	Wheels.	Wheel base.	Heating surface.		Grate area.	Pressure.	Weight in working order.			Illustrated by
						Tubes.	Fire-box.			sq. ft.	Total.	Bogie.	
1 G.E.R., 1900	J. Holden	1900	19" x 26"	3' 9", 7"	6' 6" + 8' 4 9/16"	1516.5	114	1630.5	180	16 1/2	16 1/2	50 8 1/2	Fig. 413
2 M.R., 700	S. W. Johnson	1900	19 1/2" x 26"	3' 3 1/2", 6' 9"	6' 6" + 7' 5 1/2" + 9' 6"	1383	145	1528	185	17 1/4	16 19 1/2	53 4	
3 G.C.R., 1017	J. G. Robinson	1901	18 1/2" x 26"	3' 6", 6' 9"	6' 0" + 8' 1 3/4" + 9' 9"	1248	180	1378	180	17 4	18 0	52 1/2	Fig. 411
4 G.W.R., "City"	A. Dean	1903	18" x 26"	3' 2", 6' 8 1/2"	6' 6" + 7' 6" + 8' 6"	1689.8	128.3	1818.1	195	19 4	17 8	55 6	Fig. 412
5 G.W.R., "County"	G. J. Churchward	1904	18" x 26"	3' 2", 6' 8 1/2"	7' 4' 8" + 8' 6" + 10'	1689.8	128.3	1818.1	200	21 4	18 4	58 16	
6 L. & N.W.R., 513	G. Whale	1904	19" x 26"	3' 9", 6' 9"	6' 3" + 8' 10 1/2" + 10'	1848.4	161.3	2009.7	175	16 17	19 0	53 19	
7 L. & S.W.R., 415	D. Drummond	1904	19" x 26"	3' 7", 6' 7"	6' 3" + 8' 10 1/2" + 10'	1222	328	1550.7	224	17 5	18 0	58 15	
8 M.R., 990	R. M. Deeley	1907	19" x 26"	3' 7", 6' 7"	6' 3" + 8' 10 1/2" + 10'	1401.6	152.8	1557.4	220	19 14 1/2	38	59 14 3/4	
9 N.E.R., 1237	W. Worsdell	1908	19" x 26"	3' 7 1/2", 6' 6 1/2"	6' 7 1/2" + 8' 3" + 9' 6"	1572	138	1737	225	17 10	42	59 10	
10 L. & N.W.R., 2663	C. J. Bowen Cooke	1910	20 1/2" x 26"	3' 6", 6' 9"	6' 8" + 7' 9" + 9' 6"	1380.4	101.7	1524.1	200	19 12	19 3	59 17	Fig. 415
11 L. & S.W.R., 463	D. Drummond	1912	19 1/2" x 26"	3' 6", 6' 9"	6' 8" + 7' 9" + 9' 6"	1406	318	1764	210	19 10	18 10	59 10	
12 C.R., 120	J. F. McIntosh	1912	20 1/2" x 26"	3' 6", 6' 9"	6' 6" + 7' 7" + 9' 9"	1220	149	1369	180	21 8	39	61 0	Fig. 414
13 G.C.R., 429	J. G. Robinson	1913	20" x 26"	3' 6", 6' 9"	6' 6" + 8' 3" + 10'	1602	147	1749	180	21 18 1/2	39	61 7 1/2	
14 G. & S.W.R., 131	P. Drummond	1913	19 1/2" x 26"	3' 6", 6' 8"	6' 6" + 8' 3" + 10'	1736	188	1854	170	19 13	18 9	57 9	
15 S.E. & C.R., 760	H. S. Vainwright	1914	20 1/2" x 26"	3' 7", 6' 8"	6' 3" + 8' 9 1/2" + 10'	1252	160	1412	160	19 13	18 9	57 9	

* These engines were fitted with steam dryers and fire-box water tubes.

TABLE XIV.—4-4-2 Engines 1903 to 1911.

Railway and Class.	Designer.	Date.	Cylinders.	Wheels.	Wheel base.	Heating surface.		Grate Area.	Pressure.	Weight in working order.			Illustrated by
						Tubes.	Fire-box.			sq. ft.	Total.	Bogie.	
G.N.R., 251	H. A. Ivatt	1902	18 1/2" x 24"	3' 7 1/2", 6' 7 1/2", 3' 7 1/2"	6' 3" + 5' 3" + 6' 10" + 8' 3"	2359	141	2500	175	17 6	36 0	68 8	
G.C.R., 263	J. G. Robinson	1903	19 1/2" x 26"	3' 6", 6' 9", 4' 3"	6' 6" + 5' 9 1/2" + 7' 3" + 8' 3"	1777.9	133.1	1911	180	14 9	37 0	66 16	
N.E.R., 532	W. Worsdell	1903	20" x 28"	3' 7 1/2", 6' 10", 4'	6' 6" + 5' 11" + 7' 7" + 8' 8"	2275.8	180	2455.8	226	20	39 0	72 0	Fig. 417
G.W.R., 180	G. J. Churchward	1905	18" x 30"	3' 2", 6' 8 1/2", 4' 1 1/2"	7' 4" + 5' 4" + 7' 4" + 8' 3"	1988.6	154.3	2142.9	225	17 10	39 0	70 10	
N.B.R., 868	W. P. Reid	1906	20" x 28"	3' 6", 6' 9", 4' 3"	6' 6" + 5' 9 1/2" + 7' 3" + 8' 3"	2071.4	184.8	2256.2	200	15 18	40 0	74 8	Fig. 416
L.B. & S.C.R., 421	D. E. Marsh	1911	21" x 26"	3' 6", 6' 7 1/2", 3' 6"	6' 3" + 5' 3" + 6' 10" + 8' 3"	1913	136.7	2049.7	170	17 10	37 10	68 10	

TABLE XV.—4-6-0 Engines 1902 to 1914.

Railway and class.	Designer.	Date.	Cylinders.	Wheels.	Wheel base.	Heating surface.		Grate area.	Pressure.	Weight in working order.			Illustrated by
						Tubes.	Fire-box.			sq. ft.	Total.	Bogie.	
1 G.W.R., 2900	G. J. Churchward	1902	18" x 36"	3' 2", 6' 8 1/2"	14' 9"	1988.6	154.3	2142.9	225	16 0	18 0	70 4	
2 G.C.R., 195	J. G. Robinson	1903	19 1/2" x 26"	3' 6", 6' 9"	14' 6"	26' 9 1/2" + 17' 7" + 8'	133.1	1911	180	15 3	17 7	67 13	
3 G. & S.W.R., 124	J. Mansont	1911	21" x 26"	3' 8", 6' 6"	15'	27' 11" + 14' 30" + 15' 60"	130	1560	165	17 10	18 0	69 2	Fig. 418
4 C.R., 49	J. F. McIntosh†	1903	21" x 26"	3' 9", 6' 6"	15'	2255	145	2400	200	19 11 1/2	33 8 1/2	73 0	Fig. 421
5 L. & N.W.R., 819	C. J. Bowen Cooke	1911	20" x 26"	3' 6", 6' 9"	13' 7"	28' 8 1/2" + 14' 39" + 14' 33"	133.3	1572.9	226	19 10	15 5	66 0	
6 G.E.R., 1300	S. D. Holden	1911	20 1/2" x 26"	3' 6", 6' 9"	14'	28' 6" + 14' 39" + 14' 33"	143.5	1632.6	180	20 0	14 0	73 5	Fig. 419
7 G.C.R., 423	J. G. Robinson	1912	21 1/2" x 26"	3' 6", 6' 9"	15' 6"	28' 10" + 22' 10" + 16' 7"	167	2377	180	18 13	14 0	73 5	Fig. 420
8 G.W.R., 4001	G. J. Churchward	1907	14 1/2" x 26"	3' 2", 6' 8 1/2"	14' 9"	27' 3" + 15' 3" + 15' 3"	154.3	2142.9	225	20 4	18 12	75 12	
9 L. & S.W.R., 335	D. Drummond	1907	16 1/2" x 26"	3' 7", 6' 9"	13' 4"	26' 10" + 22' 10" + 17' 7"	140	1727	175	21 10	16 10	74 0	
10 L. & S.W.R., 443	D. Drummond	1911	15" x 26"	3' 7", 6' 9"	14' 4"	27' 7" + 16' 36" + 17' 6"	310*	1976	200	22 10	18 0	74 10	
11 L. & N.W.R., 1506	G. Hughes	1908	16" x 26"	3' 9 1/2", 6' 3"	13' 7"	25' 4" + 23' 17" + 19' 11"	200	2507	180	19 13	19 15	78 11 1/2	
12 L. & N.W.R., 2222	C. J. Bowen Cooke	1913	16" x 26"	3' 3", 6' 9"	15' 3"	1647.2	171.2	1818.4	175	18 15	19 15	77 15	Fig. 422
13 G.W.R., 4046	C. J. Churchward	1914	15" x 26"	3' 2", 6' 8 1/2"	14' 9"	1686.6	154.7	1841.3	225	20 4	18 12	75 12	

* With fire-box water tubes.

† The engines illustrated are similar in appearance, though of slightly different dimensions from those given in the Table.

are placed in front of the cylinders, as in Webb's design of 1897.

The G.W.R. engines (13) are an enlargement of the earlier class and are provided with superheaters.

423, and had the following dimensions:—Cylinders (four), 15in. by 26in.; diameter of coupled wheels, 6ft. 8½in.; coupled wheel base, 14ft.; total ditto, 34ft. 6in.; the trailing carrying wheels, 3ft. 8in. diameter, ran in

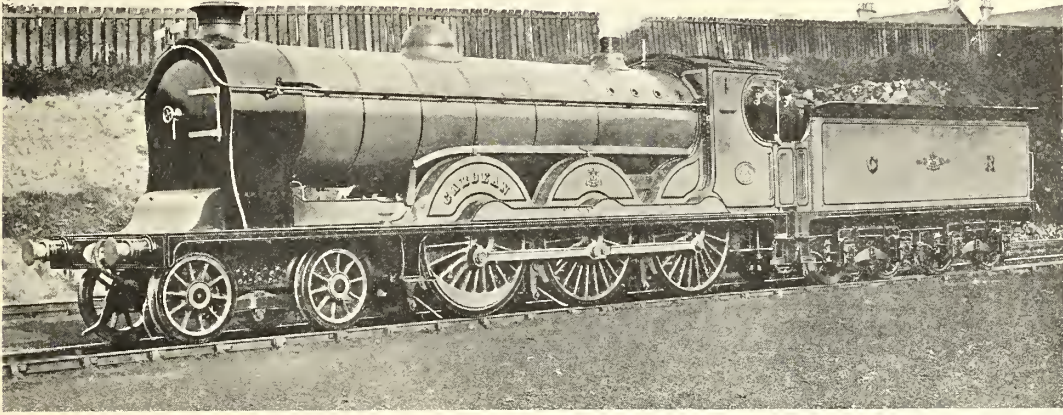

FIG. 421—J. F. McINTOSH'S PASSENGER ENGINE, CALEDONIAN RLY., 1906 [Photo. Locomotive]

4-6-2 Express Engine.—In January, 1908, the G.W.R. engine, "The Great Bear," was built at Swindon to Mr. Churchward's designs. This was the first "Pacific" tender engine in Britain, and until 1922 remained the only example in this country. It is illustrated by Fig.

a radial axle-box; boiler barrel, 23ft. long, tapering from 5ft. 6in. diameter at the smoke-box to 6ft. at the fire-box. The brick arch was originally carried by four 3in. steel tubes, but these burnt out, and were replaced by an ordinary brick arch. Omitting the arch tubes the fire-box

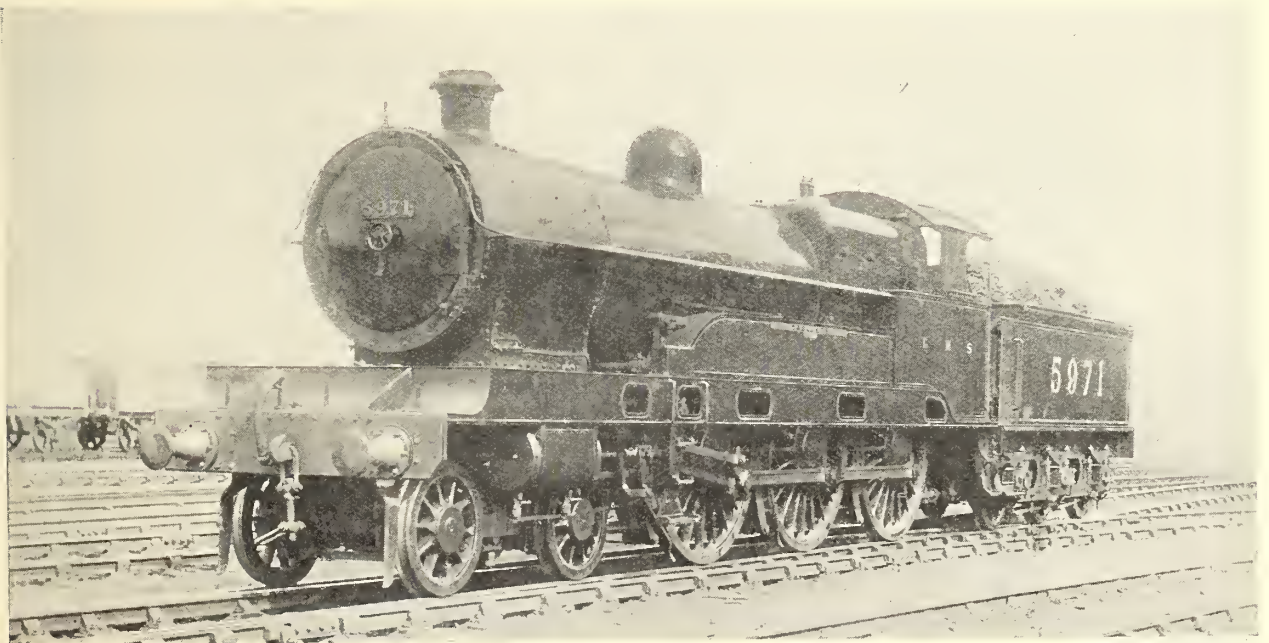

FIG. 422—C. J. BOWEN COOKE'S FOUR-CYLINDER EXPRESS ENGINE, L. & N.W.R. (NOW L.M. & S.R.), 1913 [Photo. Locomotive]

heating surface was 158.1 square feet; tubes, 2673.4 square feet; total, 2831.5 square feet; superheating surface, 545 square feet; grate, 41.79 square feet; pressure, 225 lb.; each coupled axle carried 20.45 tons; and the total weight was 97.25

of one of Webb's compound engines of 1889, which was tried temporarily with the middle cylinder 20in. instead of 30in. diameter, all three cylinders receiving steam from the boiler. Some early engines of the type were made in America

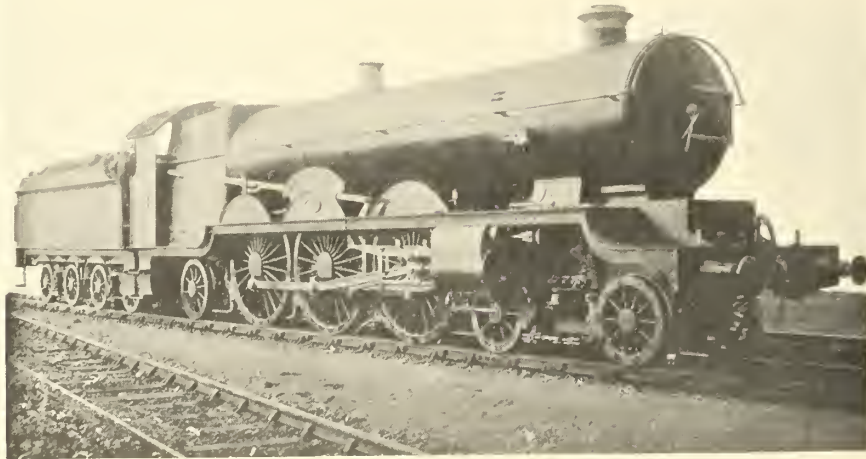

FIG. 423—G. J. CHURCHWARD'S 4-6-2 EXPRESS ENGINE, "THE GREAT BEAR," GREAT WESTERN RLY., 1908

tons. The double bogie tender weighed 45.75 tons full. "The Great Bear" ran only between London and Bristol, and in 1924 Mr. C. B. Collett reconstructed it as a 4-6-0 engine of the new "Caerphilly Castle" class. The 4-6-0 engine has a tractive force of 31,625 lb., and a ratio of adhesive to total weight of .737, whereas the 4-6-2 engine had a tractive force of 29,430 lb., and a similar ratio of .63.

in 1847-48 and in 1892. The Wyoming Valley Railway, U.S.A., had a few locomotives of different types, including 4-4-0 passenger engines, with cranks at 120 deg. In 1902 0-6-2 three-cylinder passenger tank engines were built in Germany for local traffic in the Berlin area.

The first of the later three-cylinder express engines appeared in this country in March, 1909, when Mr. J. G. Robinson converted a standard



FIG. 424—SIR VINCENT RAVEN'S THREE-CYLINDER "ATLANTIC" TYPE ENGINE, NORTH-EASTERN RLY., 1911-17

Three-cylinder Non-compound Express Engines.—After Stephenson's three-cylinder engine of 1846, no further high-pressure passenger engines with three cylinders were built in this country until the end of 1902, when J. Holden's ten-coupled tank engine appeared, unless exception be made

"Atlantic" engine of the G.C.R. by replacing the two outside 19½in. cylinders by three 15½in. by 26in. The two outside cylinders drove the hind and the inside cylinder the front coupled axle. Outside and inside Walschaerts valve gears were used. This was the only example of a non-

compound three-cylinder engine with divided drive. In 1922 the engine was reconverted to the two-cylinder type.

In 1911 Sir Vincent Raven designed and the North British Locomotive Company built the first twenty of the standard N.E.R. three-cylinder "Atlantic" express engines, one of which is shown by Fig. 424.¹⁴ Their principal characteristics are that all three cylinders, cast in one piece with their piston valve chests, drive the front coupled axle, and that three Stephenson valve gears with six excentrics are used. The cranks are at 120 deg. The cylinders are 16½ in. by 26 in.; coupled wheels, 6 ft. 10 in. diameter; wheel base, 6 ft. 6 in. + 7 ft. 5 in. + 7 ft. 7 in. + 8 ft. = 29 ft. 6 in.; boiler, 5 ft. 6 in. diameter; heating surface of the later engines built at Darlington, tubes, 1295.8 square feet; fire-box, 180 square feet; total, 1475.8 square feet; superheater elements, 530 square feet; grate area, 27 square feet; pressure, 160 lb.; total weight in working order, 77.1 tons.

Whilst the four-cylinder non-compound express engines are practically all of the 4-6-0 type, all

The three cylinders were 18½ in. by 24 in., placed horizontally, those outside driving the third axle, the inside one driving the second axle by means of a connecting-rod in the form of a triangular frame which embraced the leading axle. The cranks were at 120 deg. The six excentrics were placed inside on the third axle. The trailing axle had 1½ in. lateral play, to allow of which the coupling-rod pin and bush formed a ball and socket joint, and the back length of rod had a knuckle joint in front. The fire-box was of the Wootten type with direct stayed arched roof, the casing being 7 ft. 9½ in. wide outside. The tanks, of 1300 gallons capacity, were underneath the trailing end, and between the frames in front of the fire-box. The exhausts terminated in three annular blast-pipe cones independent of each other. The sanding gear was automatic, worked by air simultaneously with the opening of the regulator. The wheels were 4 ft. 6 in. diameter; wheel base, 19 ft. 8 in., equally divided. The boiler, 5 ft. 1¾ in. diameter inside the middle (smallest) ring, contained 395 1¾ in. tubes, giving

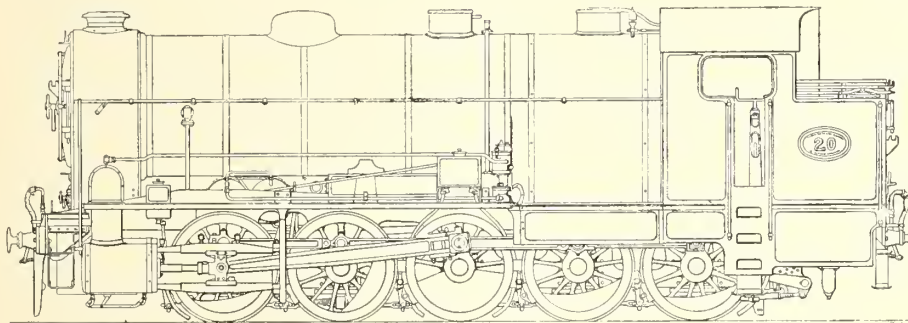

FIG. 425—J. HOLDEN'S THREE-CYLINDER DECAPOD TANK ENGINE, GREAT EASTERN RLY., 1902

the three-cylinder engines had only four wheels coupled until the advent of Mr. Gresley's 4-6-2 engines of 1922. This may be due to the preferences of the respective designers, but, on the other hand, with the more even torque of the three-cylinder engine a higher draw-bar pull may be produced per ton of weight on the coupled wheels within the limits of adhesion.

Three-cylinder Tank Engines.—Although there were no other three-cylinder tender engines during this period, there were several very interesting types of tank engines. At the end of 1902 J. Holden built a 0-10-0 tank engine—Fig. 425—at the G.E.R. works for heavy suburban traffic, for which quick acceleration was the principal object. It was the third three-cylinder engine in this country since Stephenson's engine of 1846-53,¹⁵ and was also the first having ten wheels coupled.

¹⁴ Drawings appeared in *THE ENGINEER*, November 3rd, 1911, and a full description in *THE LOCOMOTIVE* for May and June, 1925.

¹⁵ The second was a 0-6-0 goods tender engine built in 1868 by the Blyth and Tyne Railway with three cylinders arranged similarly to Stephenson's engine of 1846.

a heating surface of 2878.3 square feet; total, 3010 square feet; grate, 42 square feet; pressure, 200 lb.; tank capacity, 1400 gallons; total weight loaded, 80 tons, the maximum axle load being 16¾ tons. The load per foot run of wheel base was 4.06 tons, an extremely high figure.

The engine was built experimentally to ascertain whether a steam locomotive could accelerate as well as an electric locomotive, since electrification had been suggested for the suburban services. The electric people said that a train of 315 tons could be accelerated to 30 miles per hour from the start in thirty seconds, equivalent to 1.46 ft. per second per second. Holden's engine actually accelerated a new train of eighteen coaches, weighing 335 tons, at a rate of 1.4 ft. per second per second in very windy weather. Nevertheless it did little actual service, and in 1906 was reconstructed as a 0-8-0 tender engine. In its original form the load per foot run of wheel base was too great. In the tender engine, by increasing the wheel base it was reduced to 2.34 tons. It should be added that, when the ten-coupled engine

was designed, it was recognised that the scheme which proposed the use of such engines involved the strengthening of many bridges, especially between Liverpool-street and Stratford, and although the cost of the steam scheme was said to have been less than that of the electric proposals,

utilise parts interchangeable with existing 0-8-0 tender engines. Cylinders, 18in. by 26in.; coupled wheels, 4ft. 8in. diameter. The inside cylinder drives the second and the outside cylinders the third axle, with cranks at 120 deg. Coupled wheel base, 17ft. 1in.; bogie base, 7ft. 6in.; total



FIG. 426—J. G. ROBINSON'S THREE-CYLINDER SHUNTING ENGINE, GREAT CENTRAL RLY., 1907



FIG. 427—W. WORSDELL'S THREE-CYLINDER SHUNTING TANK ENGINE, NORTH-EASTERN RLY., 1909

both were abandoned subsequently on account of the great outlay involved and a falling-off of traffic which had since taken place.

The three-cylinder shunting side tank engines, built in 1907 by Beyer, Peacock and Co. for the G.C.R. to J. G. Robinson's designs, were of the 0-8-4 type, this arrangement being selected to

base, 30ft. 8in.; total heating surface, 1931 square feet; pressure, 200 lb.; tank capacity, 3000 gallons; fuel, 5 tons; total weight in working order, 96.7 tons, of which 74 tons are carried on the coupled wheels. Fig. 426 illustrates one of these engines.

The first N.E.R. three-cylinder locomotives

were also heavy hump-shunting side tank engines, built in 1909 at Gateshead Works to W. Worsdell's designs. In contradistinction to the G.C.R. engines they are of the 4-8-0 type. The drive is divided and the cranks are at 120 deg.;

by 26in. cylinders, all driving the first coupled axle, an arrangement since adhered to in all N.E.R. three-cylinder engines, in conjunction with piston valves driven from six inside eccentrics and Stephenson's gear. The coupled wheels are



FIG. 428—SIR V. RAVEN'S THREE-CYLINDER 4-6-2 TANK ENGINE, NORTH-EASTERN RLY., 1910

cylinders, 18in. by 26in.; coupled wheels, 4ft. 7 $\frac{1}{4}$ in.; wheel base of bogie, 6ft. 6in.; coupled wheels 15ft. 3in.; total, 29ft.; total heating surface, 1310 square feet; pressure, 175 lb.; tank capacity, 2500 gallons; weight on coupled wheels, 66.85 tons; total, 84.65 tons. Fig. 427 shows one of these engines.

4ft. 7 $\frac{1}{4}$ in.; rigid wheel base, 14ft. 6in.; and total base, 34ft. 3in.; total heating surface, 1648 square feet; pressure, 180 lb.; tank capacity, 2300 gallons; coal, 5 tons; weight in working order, 87.4 tons, of which 55.6 tons rest on the six-coupled wheels.

The N.E.R. 4-4-4 superheated passenger tank

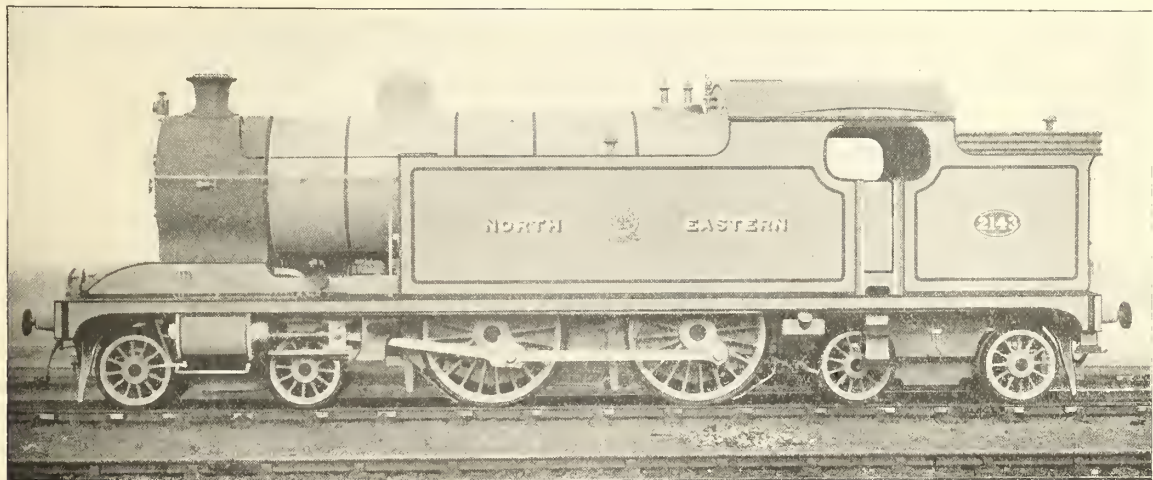

FIG. 429—SIR V. RAVEN'S THREE-CYLINDER PASSENGER TANK ENGINE, NORTH-EASTERN RLY., 1913

From this time the three-cylinder engine made steady headway on the N.E.R. Sir V. Raven's 4-6-2 mineral side tank engines, built in 1910 at Darlington, illustrated by Fig. 428, have 16 $\frac{1}{2}$ in.

engines with three cylinders followed in 1913. Cylinders, 16 $\frac{1}{2}$ in. by 26in.; coupled wheels, 5ft. 9in. diameter; wheel base, 6ft. 6in. + 7ft. 3in. + 8ft. + 6ft. 3in. + 6ft. 6in. = 34ft. 6in.; tube

heating surface, 934.8 square feet; fire-box, 124 square feet; total, 1058.8 square feet; superheating surface, 273 square feet; grate, 23 square feet; pressure, 160 lb.; tank capacity, 2000 gallons; weight on coupled wheels, $39\frac{3}{4}$ tons; total weight,

Bottomley types are used, except in the G.W.R. 2-6-2 engines (9) and (10), which have radial axle-boxes at the trailing and pony trucks at the leading end. The springs of the front coupled wheels of the G.W.R. engines are connected by compen-

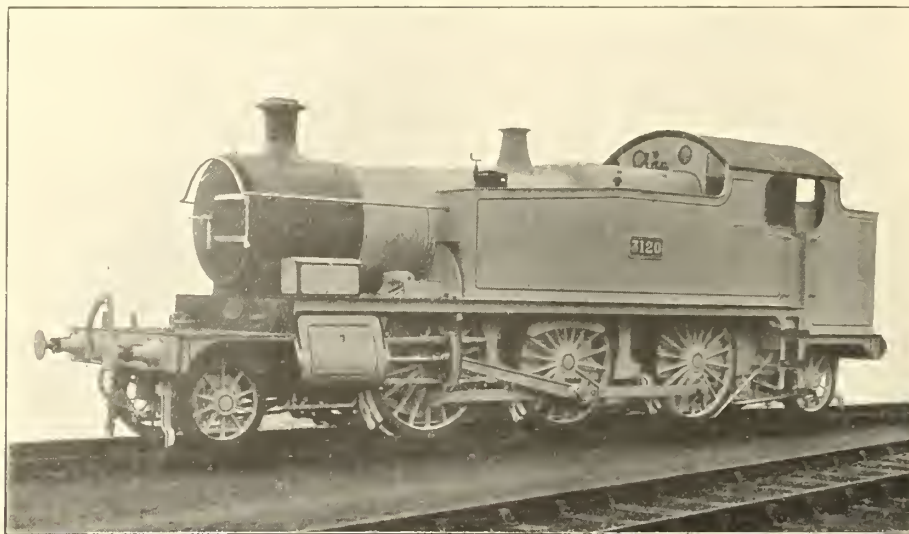

FIG. 430—G. J. CHURCHWARD'S 2-6-2 TANK ENGINE, GREAT WESTERN RLY., 1905

$84\frac{3}{4}$ tons. These engines, which replaced old tender engines on long cross-country lines, are illustrated by Fig. 429. They were built down to 1922, and there are forty-five in service.

Passenger Tank Engines, Two-cylinder Type.—The principal features of progress were the gradual increase in heavy six-coupled passenger tank engines, and in the designs of tank engines for main line fast trains for distances up to about 80 miles. The 0-4-4 type was still built by the

sating levers to those of the pony truck and the springs of the hind coupled and radial wheels are similarly connected. The driving wheels have independent springs. Fig. 430 illustrates one of the type with 5ft. 8in. wheels. The other 2-6-2 tank engines in the table have inside cylinders.

The 2-6-2 tank engines (8) of the L. and Y.R. proved somewhat unsteady on passenger trains; some have been broken up and the others relegated to banking services. The N.E.R. 4-6-0 engines



FIG. 431—D. E. MARSH'S PASSENGER TANK ENGINE, L.B. & S.C. RLY., 1912

L. & S.W. and S.E. & C. Rlys. for local traffic, and the 2-4-2 type by the L. and Y.R., on which line the later engines were superheated and frequently used for main line fast trains. Table XVI on page 342 gives a summary of the various types. In engines with a single axle at one or both ends radial axle-boxes of the Webb or

(11), which were built for the Whitby district, have since been converted to the 4-6-2 type. The springs of the coupled wheels were connected by compensating levers.

Fig. 431 illustrates the second of the 4-6-2 superheater express passenger tank locomotives, designed by Mr. D. E. Marsh, locomotive superin-

tendent of the London, Brighton and South Coast Railway, and built at Brighton works in 1912. The first L.B. and S.C. engine of this type, built in 1910, was fitted with Stephenson valve gear, but the one illustrated has the Walschaerts motion. The leading dimensions are given in Table XVI

sq. ft.; grand total, 2,070 sq. ft. Grate area, 26.7 sq. ft. The tank capacity of 2,700 gallons of water and bunker accommodation for $3\frac{1}{2}$ tons of coal is sufficient for the journey from Victoria to Portsmouth Harbour, 87 miles. Other dimensions are given in Table XVI, No. 18. Feed-water in

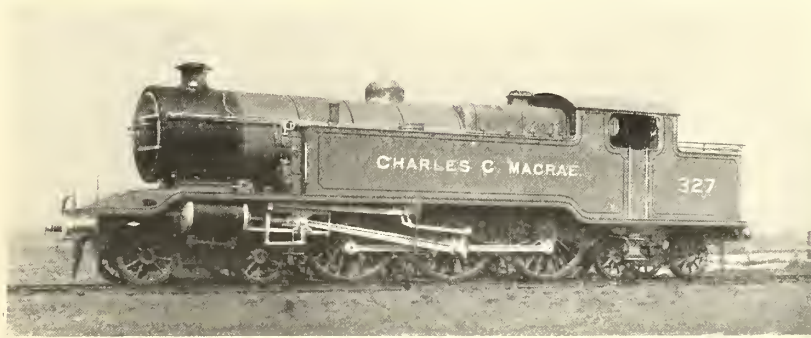

FIG. 432—L. B. BILLINTON'S PASSENGER TANK ENGINE, L.B. & S.C. RLY., 1914

(No. 14), and it is noteworthy that the total weight, in working order, with 2,000 gallons of water and 3 tons of coal, is 86 tons, of which 56 tons are on the coupled wheels. The total heating surface is 1,865 sq. ft., of which the fire-box provides 125 sq. ft.; the flue-tubes 1,398, and the superheater tubes 342 sq. ft.

The 4-6-4 type tank locomotive shown by Fig. 432 was built at Brighton works in 1914 to the designs of Mr. L. B. Billinton for working express trains on the L.B. and S.C. Railway main line, and was practically an enlargement of the two "Pacific" type tank engines of 1910 and 1912. It is provided with a large boiler carrying a working pressure of 170 lb. per sq. inch, and a fire-box of the Belpaire pattern. The bogies have

the tank is heated by exhaust steam, and fed to the boiler by a Weir pump on the side of the engine. The total weight, in working order, is 98 tons, of which $56\frac{1}{2}$ tons are available for adhesion.

The great increase in tank capacity may be noted. Before the end of last century it was, with few exceptions, about 1000 to 1200 gallons. Fig. 433 shows the Great Central (L. and N.E.) type 4-6-2 tank engine, No. 16 in Table XVI.

Goods Tender Engines, 0-6-0 Type.—For fast main line goods traffic, the 0-6-0 engines on several lines were replaced by 2-6-0 and 4-6-0 engines with larger wheels, 5ft. 6in. to 6ft. diameter, though on others, notably the Midland, the 0-6-0 type was retained, the later engines having super-

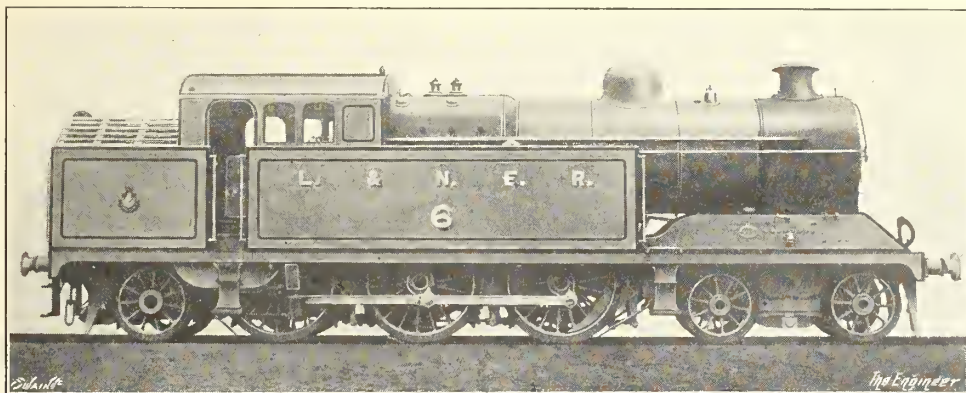

FIG. 433—J. G. ROBINSON'S TANK ENGINE, GREAT CENTRAL RLY. (NOW L. & N.E. RLY.), 1911-23

side bolsters, and are arranged for sufficient side play for the engine to pass round curves of 5 chains radius. The heating surface is: 123 tubes of $2\frac{1}{4}$ in. diameter outside, 1,082 sq. ft.; 21 tubes of $5\frac{1}{2}$ in. diameter outside, 453 sq. ft.; fire-box, 152 sq. ft.; total, 1,687 sq. ft.; superheater, 383

heaters. Sir Henry Fowler's 0-6-0 Midland engines, first built in 1911, but principally since 1917, are good examples of British modern practice. They have 20in. by 26in. cylinders with piston valves; 5ft. 3in. coupled wheels; tube heating surface, 1045 square feet; fire-box,

Belpaire, 125 square feet; total, 1170 square feet; additional superheating surface, 313 square feet; grate, 21.1 square feet; pressure, 160 lb.; weight in working order, 49.1 tons. These engines replaced the earlier non-superheated type of 1903-7 which had 18½ in. by 26 in. cylinders and 175 lb. pressure. A large number of the Midland superheated type have recently been built at Derby, Crewe and St. Rollox for the L.M.S. Railway.¹⁶

2-6-0 Goods Engines.—These comprised three different types. The G.W.R. engines of 1901-3, originally designed by W. Dean, were unique in having double frames and four bearings for the coupled axles, with pony trucks having inside bearings only—Fig. 434. Cylinders, 18 in. by 26 in., with piston valves; wheels, 2 ft. 8 in. and 4 ft. 7½ in. diameter; wheel base, 22 ft. 6 in., equally divided. The boiler of Mr. Churchward's design with taper wagon top is 4 ft. 10¾ in. diameter outside the front ring, and 5 ft. 6 in. diameter at the back. Heating surface of Belpaire fire-box, 128.7 square feet; total evaporating surface, 1478.3 square feet; superheating surface, 249.7 square feet; grate, 20.56 square feet; pressure, 200 lb.; weight in working order on coupled wheels, 49.15 tons; total 56.25 tons. The superheater was added subsequently.

Another type, new to British practice, originated in 1912 on the Caledonian Railway to J. F. McIntosh's design. This class differed from those previously described as it had inside cylinders and bearings as well as a leading pony truck, the latter being introduced owing to the extra weight of larger cylinders, 19½ in. by 26 in., and a superheater. The truck wheels are 3 ft. 6 in. and the coupled wheels 5 ft. diameter; pressure, 160 lb.; weight in working order, 54½ tons. Only five of these engines were built; they succeeded non-superheated 4-6-0 engines.¹⁷

Eleven similar engines were built by the North British Locomotive Company in 1915 for the Glasgow and South-Western Railway, to P. Drummond's designs—Fig. 435. Cylinders, 19½ in. by 26 in.; wheels, 3 ft. 6 in. and 5 ft. diameter; wheel base, rigid, 17 ft. 1 in.; total, 23 ft. 7 in.; evaporative heating surface, 1491 square feet; superheating surface, 211 square feet; grate, 26½ square feet; pressure, 180 lb.; weight in working order, 62 tons, of which 54.35 tons are available for adhesion.

These are the only 2-6-0 engines with inside cylinders on British railways, but those with outside cylinders are much more numerous. The G.W.R. standard engines by Mr. G. J. Churchward were introduced in 1911, and have 18½ in. by 30 in. cylinders, 5 ft. 8 in. coupled wheels, evaporative heating surface, 1350.9 square feet;

¹⁶ Drawings appeared in THE ENGINEER, December 29th, 1911, and they are illustrated in THE LOCOMOTIVE for January 15th, 1912.

¹⁷ See THE LOCOMOTIVE, August 15th, 1913.

TABLE XVI.—Principal Tank Engines: British Railways, 1901 to 1914.

No.	Railway.	Designer.	Date.	Type.	Cylinders, i=inside, o=outside.	Driving wheels, dia.	Wheel base.		Total H.S.	Super- heater surface, sq. ft.	Pressure	Tank capacity, gallons.	Weight in working order.		Illustrated by
							Coupled.	Total.					On coupled wheels.	Total.	
1	L. & Y.R.	G. Hughes	1911	2-4-2	26½" x 26", 1	5' 8"	8' 7"	24' 4"	897	195	180	1540	39.25	66.45	Fig. 430
2	G.C.R.	J. G. Robinson	1903-1907	4-4-2	18" x 26", 1	5' 7"	9' 1"	29' 10½"	1143	—	160	1430	31.65	62.85	
3	G.W.R.	G. J. Churchward	1905	4-4-2	18" x 30", 0	6' 8½"	8' 6"	32' 0"	1517.9	—	195	2000	37.1	71.75	Fig. 431
4	L. & N.W.R.	G. Whale	1906	4-4-2	19" x 26", 1	6' 3"	10' 0"	32' 7½"	2009.7	—	175	1700	37.0	75.0	
5	L. & S.R.	F. Whitelegg	1909	4-4-2	19" x 26", 0	6' 6"	8' 9"	30' 9½"	1130	—	170	1926	39.5	74.75	Fig. 432
6	L.B. & S.C.R.	D. E. Marsh	1908	4-4-2	21" x 26", 1	6' 7½"	8' 9"	31" 2"	976	305	160	2110	38.0	74.0	
7	L.B. & S.C.R.	H. A. Ivatt	1907	0-6-2	18" x 26", 1	5' 8"	16' 3"	23' 9"	1250	—	170	1600	31.35	65.85	Fig. 433
8	L. & Y.R.	H. A. Hoy	1903	0-6-2	19" x 26", 1	5' 8"	12' 7"	27' 7"	2038.6	—	180	2000	32.35	77.32	
9	G.W.R.	G. J. Churchward	1905	2-6-2	18" x 30", 0	5' 8"	14' 9"	31' 9"	1517.9	—	195	2000	34.05	75.5	Fig. 434
10	G.W.R.	G. J. Churchward	1907	2-6-2	17½" x 24", 0	5' 2"	14' 0"	28' 0"	1312	—	200	1500	47.95	62.2	
11	N.E.R.	W. Worsdell	1907	4-6-0	19" x 26", 1	5' 11"	12' 6"	26' 3"	1331	—	170	1500	32.0	69.0	Fig. 435
12	M.R.	R. M. Deely	1907	0-6-4	18½" x 26", 1	5' 7"	16' 6"	28' 0"	999	234	175	2250	32.67	72.12	
13	S.E. & C.R.	R. Wainwright	1913	0-6-4	19" x 26", 1	5' 6"	16' 6"	27' 9"	1523	—	160	2000	31.9	70.7	Fig. 436
14	L.B. & S.C.R.	D. E. Marsh	1910	4-6-2	21" x 26", 0	6' 7½"	11' 6"	33' 3"	1085.4	342	175	1700	36	86	
15	L. & N.W.R.	C. B. Cooke	1910	4-6-2	20" x 26", 1	5' 8"	14' 0"	33' 9"	1435	248.2	160	2330	34.0	86.0	Fig. 437
16	G.C.R.	J. G. Robinson	1911	4-6-2	20" x 26", 1	5' 7"	13' 0"	32' 9"	1296	214	160	2200	33.75	94.6	
17	L. & S.R. (Midland)	R. U. Whitelegg	1912	4-6-4	20" x 26", 0	6' 3"	13' 10"	38' 10"	1435	319	160	2200	33.75	94.6	Fig. 438
18	L.B. & S.C.R.	L. B. Billinton	1914	4-6-4	22" x 26", 0	6' 9"	14' 9"	40' 0"	1687	383	170	2700	56.5	98.0	

superheating surface, 215.8 square feet; grate area, 20.56 square feet; pressure, 200 lb.; and inside Stephenson's link motion; weight on coupled wheels, 52.6 tons; total, 62 tons. One of the engines of this class is illustrated by Fig. 436.

Great Western, Belpaire fire-boxes and inside Stephenson's link motion. The outside cylinders are 21in. by 26in.; coupled wheels, 5ft. 6in. diameter; coupled wheel base, 15ft. 6in.; total base, 23ft. 9in.; evaporative heating surface, 1295 square feet; superheating surface, 279 square feet;

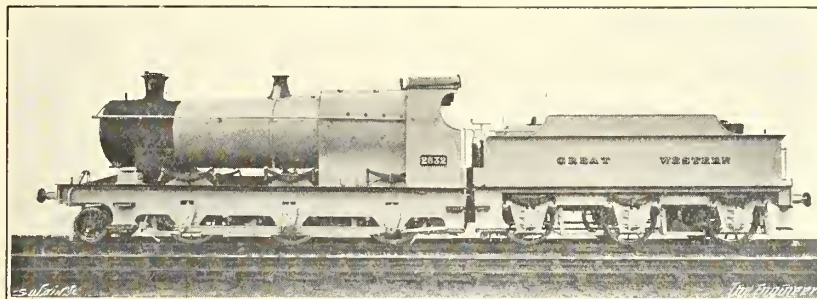

FIG. 434—W. DEAN'S GOODS ENGINE, GREAT WESTERN RLY., 1901-1903

Drawings of Mr. H. N. Gresley's G.N.R. 2-6-0 engines of 1912-13 were given in *The Engineer* of November 28th, 1913, and in *The Locomotive*, October 15th, 1912, but the later standard engines from 1914 onwards¹⁸ have larger boilers. The following dimensions apply to the latter:—Cylinders, 20in. by 26in.; coupled wheels, 5ft. 8in. diameter; coupled wheel base, 16ft. 3in.; total base, 25ft. 2in.; boiler diameter, 5ft. 6in.; evaporative heating surface, 1667 square feet; superheating surface, 403 square feet; grate area, 24 square feet; pressure, 170 lb.; weight on coupled wheels, 53.4 tons; total weight, 63.7 tons. These engines, which have outside Walschaerts gear, are without splashers, the platforms being above the wheels. The first of the G.N.R. 2-6-0 engines is shown by Fig. 437.

The L.B. and S.C.R. engines by Mr. L. B.

grate area, 24.8 square feet; pressure, 170 lb.; total weight in working order, 63.5 tons.

Locomotive with Multiple Single-acting Cylinders.—In 1908 a novel and unique type of large locomotive was constructed at the Derby works of the Midland Railway, though the chief mechanical engineer of the company was not responsible for the design. It was built in accordance with the patents of Mr. (now Sir) Cecil Paget, at that time general superintendent.

The object of the design was to secure in a locomotive good balancing with no reversal of thrust in the moving parts, while the steam distribution was controlled by rotary valves giving quick opening and release.

The engine was of the 2-6-2 type, having a pony truck at each end. There were eight single-acting cylinders 18in. diameter by 12in. stroke



FIG. 435—P. DRUMMOND'S GOODS ENGINE, GLASGOW & SOUTH-WESTERN RLY., 1915

Billinton, built in 1913,¹⁹ have, like those of the

¹⁸ See *THE ENGINEER*, January 1st, 1915, and *THE LOCOMOTIVE*, June 15th, 1914.

¹⁹ Described with drawings and illustrations in *THE ENGINEER* of January 30th, 1914, and in *THE LOCOMOTIVE*, November 15th, 1913.

with trunk pistons disposed in two groups of four, each group formed of a single casting. One group was placed between the front and the middle, and the other between the middle and the back coupled axles. The inner ends of

the two cylinders on the same side of each group communicated with one another, the two pistons moving in opposite directions, but the bores were out of line and arranged excentrically to allow of

sible, and outside frames with outside coupling-rod cranks had to be used.

Each of the two-cylinder groups had a single circular steam chest situated above it with its axis

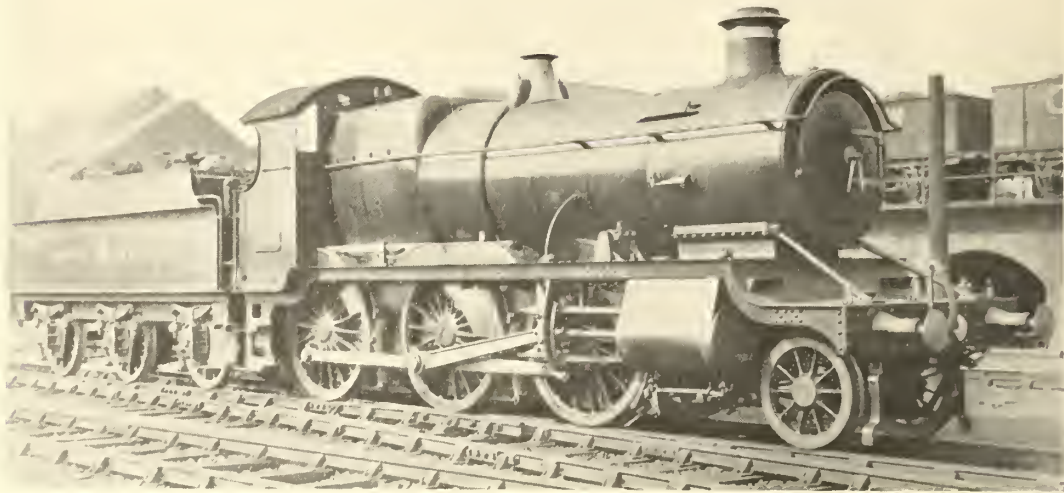

[Photo. Locomotive

FIG. 436—G. J. CHURCHWARD'S "MOGUL" MIXED TRAFFIC ENGINE, GREAT WESTERN RLY., 1911

suitable arrangement of the cranks of the middle axle. This axle had four inside cranks, two driven by pistons of the front and two by those of the back group. The front and back coupled axles each had inside cranks driven by the remaining two pistons of each of the respective groups. The

on the longitudinal centre line—in plan—of the engine. This steam chest had a bronze sleeve, through which two admission ports were made one quarter of the circumference apart, one port communicating with the two right-hand, and the other with the two left-hand cylinders of the

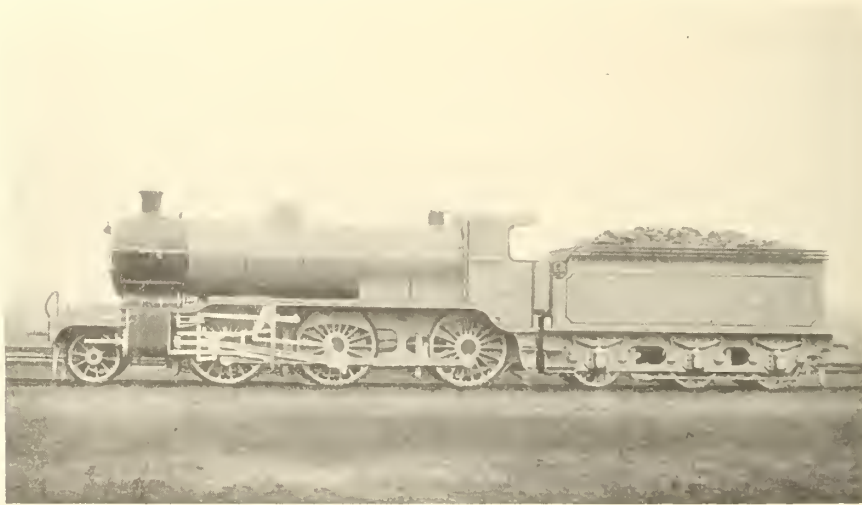

FIG. 437—H. N. GRESLEY'S MIXED TRAFFIC ENGINE, GREAT NORTHERN RLY., 1912

movements of pistons and cranks were such that the whole were balanced.

The total width of cylinder castings was such that main frames inside the wheels were not pos-

group. Since the two cylinders were practically equivalent to one with the trunk pistons back to back, the steam admitted through one of these ports entered between the pistons and moved them

in opposite directions. The steam chest contained a circular cast iron sleeve valve, which rotated continuously. As the port in the valve passed over the two ports in the steam chest in turn, steam was admitted to the right and left-hand cylinders.

The exhaust took place when the pistons overran ports in the cylinder walls, as in the uniflow system, the exhaust steam from each group of cylinders passing into a longitudinal pipe, through which it was conducted to the blast-pipe in the smoke-box.

The two sleeve valves, one for each group, were fixed on a longitudinal shaft, which derived its motion from the two coupling-rods. The latter were extended to drive outside cranks fixed on a transverse lay shaft, from which motion was communicated through bevel gears to an intermediate shaft, and the latter, in turn, actuated the longitudinal valve shaft through another pair of bevel wheels.

Reversing was effected by means of a differen-

the fire-box having an extremely wide grate, extending laterally over the frames, with fire-bars arranged in saw tooth fashion, and two fire-doors were provided. Instead of side and back water spaces a fire brick lining was substituted, somewhat on the principle of the former Hungarian Verderber fire-box. The smoke-box was provided with a hopper, from which the ashes could be ejected.

This remarkable locomotive ran only a few trial trips. It failed chiefly on account of the differential expansion of the sleeve valves and liners resulting in leakage. Although the driving wheels were only 5ft. 4in. diameter the engine on one trial run attained with ease a speed of 82 miles per hour with its train. It is now illustrated by Fig. 438. The six coupled wheels were equally spaced over a base of 17ft. 4in. The leading and trailing carrying wheels were each 3ft. 3½in. diameter at 7ft. centres from the

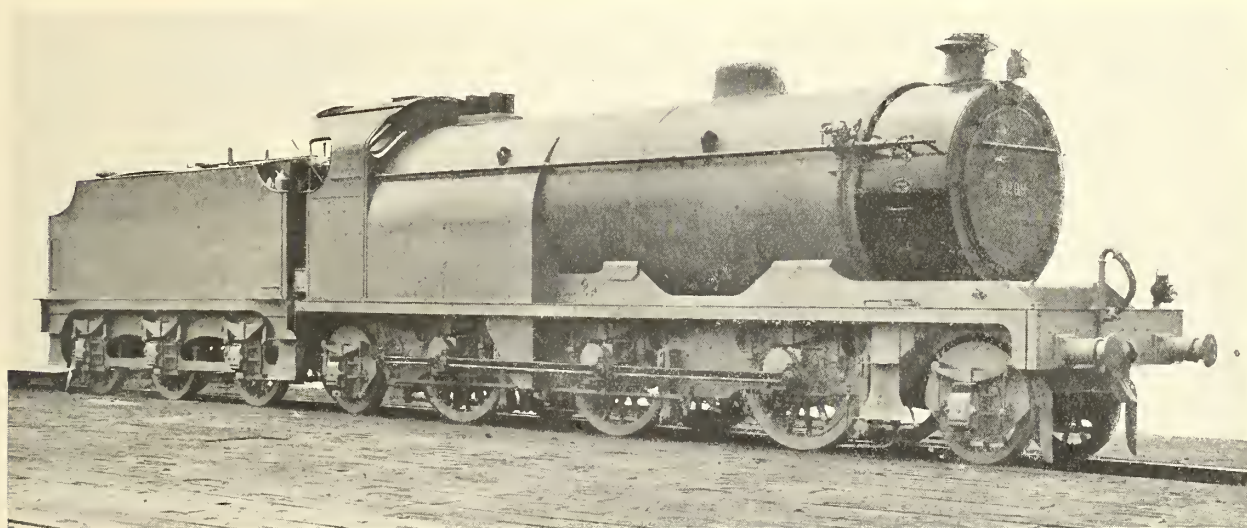

FIG. 438—SIR CECIL PAGET'S EIGHT-CYLINDER ENGINE, MIDLAND RAILWAY, 1908

tial gearing interposed in one of the shafts, somewhat after the "jack-in-the-box" type with four bevel wheels. By rotating the box by means of gearing worked from the cab, the rotary valve shaft was advanced relatively to the lay shaft, and the position of the valve with respect to the sleeve altered. The cut-off was altered by means of an arrangement whereby the driver could rotate the sleeve in the steam chest relatively to the ports in the main casting.

The middle driving axle had four inside cranks formed by bending it; the front and back driving axles each had two inside cranks, of Z form. The piston strokes were very short, the crank radii being only 6in., which was less than the diameter of the crank pins.

The boiler, which carried a working pressure of 180 lb. per square inch, also had its peculiarities. It was of ample proportions with large grate area,

front and rear coupled wheels; the total wheel base was therefore 31ft. 4in. Loaded the weights were about: on leading truck, 9½ tons; front coupled wheels, 18 tons 14 cwt.; middle coupled wheels, 18 tons 8 cwt.; rear coupled wheels, 18 tons 12 cwt.; rear truck wheels, 9 tons 6 cwt.; totalling 74½ tons approximately.

The cylinder arrangement was covered by patent No. 23,714 of 1904, and the rotary valve by patent No. 14,488 of 1905, but the general arrangement of the engine as built and described above, and the method of driving the valves from the coupling-rods instead of through chains and spur gearing, differed very considerably from the 1904 patent drawings. In the latter the two cranks of the middle axle on one side of the centre of the engine are shown at 90 deg. to one another and at 180 deg. with the corresponding cranks on the opposite side.

4-6-0 Express Goods Engines.—This type with inside cylinders was first put to work on the Caledonian Railway by J. F. McIntosh in 1902, though at first used for passenger traffic on the Oban line. The engines have 5ft. wheels, 19in. by 26in. cylinders; coupled wheel base, 11ft. 3in.; and total wheel base, 23ft. 9½in.; the trailing axle has ½in. side play. Mr. McIntosh's larger engines of 1913, illustrated by Fig. 439, have 19½in. by 26in. cylinders; 5ft. 9in. coupled wheels; coupled wheel base, 13ft. 4in.; evaporative surface, 1567 square feet; superheating surface, 403 square feet; pressure, 170 lb.; weight on coupled wheels, 51.25 tons; total weight, 68.5 tons.

The L. and N.W.R. 4-6-0 engines by G. Whale, built at Crewe from 1906,²⁰ have Joy's valve gear. Cylinders (inside), 19in. by 26in.; coupled wheels, 5ft. 2½in. diameter; coupled wheel base, 13ft. 7in.; total base, 26ft. 8½in.; total heating surface, 1984.8 square feet; pressure, 185 lb.;

180 lb. pressure; weight, 68.85 tons. One of the class, built in 1913, had Stumpf uniflow cylinders (shown by Fig. 440), but in 1924 it was rebuilt with ordinary cylinders.

The engines of the L. and S.W.R. by R. W. Urie, 1914, have 21in. by 28in. cylinders, 6ft. coupled wheels and 180 lb. pressure. The heating surface varies in accordance with the type of superheater. The engines with Robinson's superheaters have a tube heating surface of 1716 square feet; fire-box, 167 square feet; total evaporative surface, 1883 square feet; superheater, 371 square feet. These engines²² have outside Walschaerts valve gear actuating piston valves above the cylinders. The platforms are carried above the wheels.

Eight Wheels Coupled Engines.—Eight engines with 21in. by 26in. inside cylinders, built 1901-3 by the Caledonian Railway—Fig. 441—have 4ft. 6in. wheels, 2500 square feet of heating

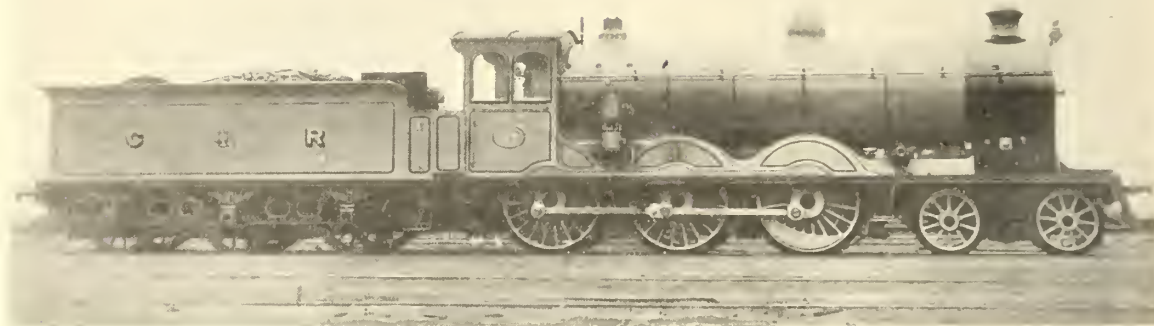

FIG. 439—J. F. MCINTOSH'S EXPRESS GOODS ENGINE, CALEDONIAN RLY., 1913

weight on coupled wheels, 44.2 tons; total weight, 63 tons. One hundred and seventy of these engines were built down to the end of 1909, after which the type was discarded.

Eleven engines were built at Gorton Works for the G.C.R. in 1913-14 to Mr. J. G. Robinson's designs.²¹ The dimensions are similar to those of the large 4-6-0 express engines of the "Sir Sam Fay" class (Fig. 420), but the coupled wheels are 5ft. 7in. diameter, the cylinders are 21½in. by 26in., evaporative heating surface 2377 square feet, superheating surface 440 square feet.

Of the 4-6-0 express goods engines with outside cylinders, those of the N.E.R. from 1911 onwards are enlargements of the 1899-1900 engines previously mentioned. The coupled wheels are 6ft. 1¼in. diameter and the cylinders 20in. by 26in.; evaporative heating surface, 1821 square feet; superheating surface, 544.8 square feet; and

surface, 180 lb. pressure, and the extremely long wheel base of 22ft. 4in. The type was not repeated, and these remained the only eight-coupled tender engines in Scotland until the grouping amalgamations.

In 1910 the L. and N.W.R. returned to Webb's original non-compound type of 1892, but with enlarged cylinders and boilers, and from 1912 onwards superheaters were added. The standard engines have inside cylinders, 20½in. by 24in., 4ft. 5½in. coupled wheels, tube heating surface 1625.7 square feet, fire-box 146.7 square feet, and additional superheating surface 378.6 square feet, pressure 160 lb., weight 60.25 tons. These engines have piston valves and Joy's valve gear.

In 1901 0-8-0 engines with outside cylinders were built by the N.E.R. to W. Worsdell's designs.²³ Cylinders, 20in. by 26in.; wheels, 4ft. 7¼in. diameter; wheel base, 17ft. 2in.;

²⁰ Illustrated in *THE ENGINEER*, January 25th, 1907, and *THE LOCOMOTIVE*, May 15th, 1907.

²¹ Illustrated in *THE ENGINEER*, January 1st, 1915, and *THE LOCOMOTIVE*, August 15th, 1913.

²² Illustrated in *THE ENGINEER* of January 23rd and May 15th, 1914, and in *THE LOCOMOTIVE* of February 14th, 1914.

²³ See *THE ENGINEER*, November 29th, 1901, and June 6th, 1902; and *THE LOCOMOTIVE MAGAZINE*, October, 1901.

total heating surface, 1699 square feet; pressure, 200 lb. In the engines of 1913 much larger boilers with superheaters were provided, and the pressure was reduced to 160 lb., but the cylinders were not enlarged.

The Great Central Railway 2-8-0 engines, first built in 1911 to Mr. J. G. Robinson's designs, have 21in. by 26in. outside cylinders driving on to the third pair of coupled wheels which are 4ft. 8in. diameter.²⁴ Coupled wheel base, 17ft.

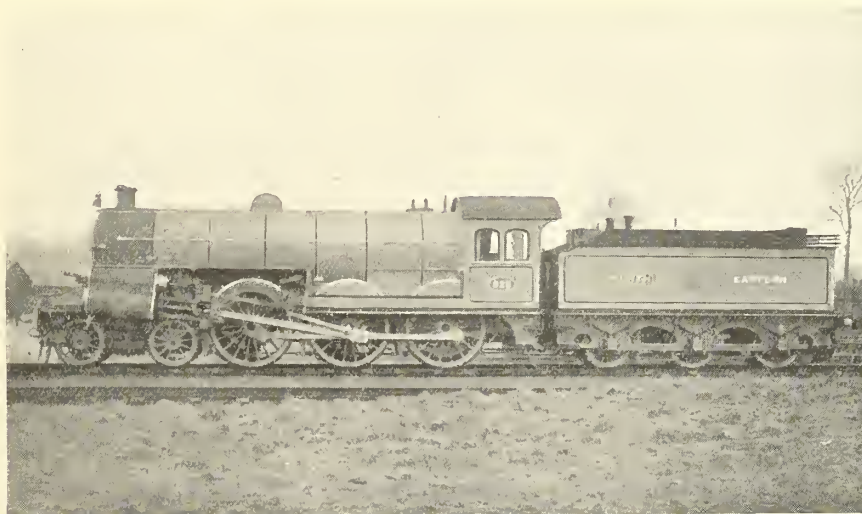

FIG. 440—STUMPF UNIFLOW CYLINDER LOCOMOTIVE, NORTHEASTERN RLY., 1913

Similar engines with 19½in. by 26in. cylinders, 4ft. 7in. wheels, and 180 lb. pressure were built in 1902-10 for the G.C.R. to Mr. J. G. Robinson's designs—Fig. 442. In all these outside-cylinder engines the drive is on the third axle and inside Stephenson's motion is used.

The 2-8-0 type made its first appearance in 1903, when Mr. Churchward designed an engine for the G.W.R. with 18in. by 30in. cylinders and 4ft. 7½in. coupled wheels. Later engines have 18½in. by 30in. cylinders; coupled wheel base, 16ft. 10in.; total base, 25ft. 7in.; tube heating surface, 1686.6 square feet; fire-box, 154.8 square

1in.; total wheel base, 25ft. 4in.; tube heating surface, 1348 square feet; fire-box, 153 square feet; superheating surface, 255 square feet; grate area, 26½ square feet; working pressure, 160 lb. per square inch in the earlier engines and 180 lb. in the later; adhesive weight, 67.15 tons; total, 73.85 tons. Inside admission piston valves were placed between the frames operated by Stephenson's link motion.

During the War, no less than 521 of these engines were built for the Railway Operating Department of the War Office for overseas military railway service, being adopted by the Government



FIG. 441—J. F. McINTOSH'S EIGHT-COUPLED MINERAL ENGINE, CALEDONIAN RLY., 1901-3

feet; superheating surface, 286.6 square feet; pressure, 225 lb.; weight, 68.3 tons, of which 61.9 tons are available for adhesion. These engines have inside Stephenson's link motion and piston valves. One is illustrated by Fig. 443.

as the standard for working heavy goods and troop trains.

The contracts for these engines were carried out by Kitson and Co., the North British Loco-

²⁴ See *THE LOCOMOTIVE*, December 15th, 1911.

motive Co., Ltd., Robert Stephenson and Co., Ltd., Nasmyth, Wilson and Co., Ltd., as well as by the Great Central Railway.

The engines for military use were fitted with the Westinghouse air brake to conform to Continental

surface, 1170 square feet; fire-box, 151 square feet; superheating surface, 360 square feet; grate, 28.4 square feet; pressure, 190 lb. The fixed wheel base is 17ft. 6in.; total, 25ft. 9in. The Walschaerts valve gear is outside. The weight in



FIG. 442—J. G. ROBINSON'S EIGHT-COUPLED MINERAL ENGINE, GREAT CENTRAL RLY., 1902-10

practice, and also steam heating apparatus for use when working troop trains. Steel fire-boxes were also adopted for these engines. They are probably the most numerous class of engine built to one design now extant.

One of the Overseas Military Railways engines purchased by the Great Western Railway after the Great War is illustrated by Fig. 444.

Mr. H. N. Gresley's G.N.R. 2-8-0 engines of 1913 have outside Walschaerts valve gear; cylinders, 21in. by 28in.; coupled wheels, 4ft. 8in. diameter; coupled wheel base, 18ft. 6in.; total, 26ft. 4in.; tube heating surface, 1922 square feet; fire-box, 162 square feet; superheating surface, 570 square feet; grate, 27 square feet; pressure, 170 lb.; weight on coupled wheels, 67.4 tons; total, 76.2 tons. Fig. 445 illustrates one of these engines.

Six 2-8-0 engines, designed by Sir Henry

working order is 64.75 tons, of which 56.025 tons are available for adhesion.

One of a further series of these engines with larger boilers built by Robert Stephenson and Co. in 1925, and shown at the Centenary Exhibition at Darlington, is illustrated by Fig. 446.

There are no 4-8-0 tender engines on British standard-gauge railways, though two built by Hudswell Clarke and Co. in 1905 for the Londonderry and Lough Swilly Railway, Ireland, 3ft. gauge are in service. One of these engines was illustrated in *The Locomotive* for October 15th, 1912. They are the only narrow gauge tender engines in Ireland, and have coupled wheels 3ft. 9in. diameter and outside cylinders 15½in. by 22in.

Eight Wheels Coupled Side Tank Engines.—The 4-8-0 and 0-8-4 three-cylinder types have been



FIG. 443—G. J. CHURCHWARD'S EIGHT-COUPLED MINERAL ENGINE, GREAT WESTERN RLY., 1903

Fowler, were built at Derby for the Somerset and Dorset Joint Railway in 1914.²⁵ The cylinders are 21in. by 28in., with 10in. piston valves above; coupled wheels, 4ft. 7½in. diameter; tube heating

²⁵ Illustrated in *THE ENGINEER* of April 24th, 1914.

mentioned. The 0-8-2 type with inside cylinders was introduced by Mr. Ivatt on the G.N.R. in 1903.²⁶ These engines had 4ft. 8in. coupled

²⁶ Illustrated in *THE ENGINEER*, August 7th, 1903, and in *THE LOCOMOTIVE MAGAZINE*, August 8th, 1903.

wheels and 19 $\frac{3}{4}$ in. by 26in. cylinders, but the cylinders were afterwards reduced to 18in. by 26in., as smaller boilers were found necessary

available for adhesion. They are shown by Fig. 447.

Similar engines built by C. J. Bowen Cooke for

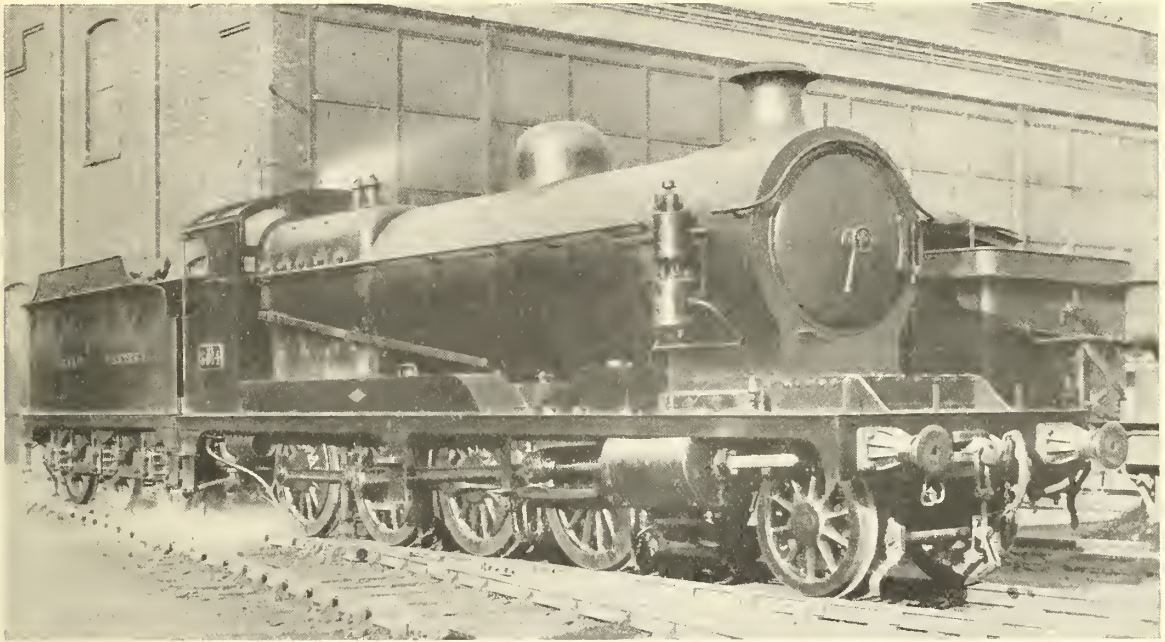

FIG. 444—J. G. ROBINSON'S HEAVY GOODS ENGINE, AS BUILT FOR THE G.C. RLY. AND OVERSEAS MILITARY RLYS., 1911-18
The engine illustrated is one of a number sold by the Government to the Great Western Rly.

to reduce the weight. The side tanks were also shortened.

Five L. and Y.R. 0-8-2 banking engines by Mr. G. Hughes, built in 1908, have 21 $\frac{1}{2}$ in. by 26in. cylinders, 4ft. 6in. coupled wheels, and 180 lb. pressure. The cylinders were then the largest in

the L. and N.W.R., in 1911, have 20 $\frac{1}{2}$ in. by 24in. cylinders and 4ft. 5 $\frac{1}{2}$ in. coupled wheels.

G.W.R. side tank engines of the 2-8-0 type have outside cylinders, 18 $\frac{1}{2}$ in. by 30in., 4ft. 7in. wheels, and 200 lb. pressure; weight, 78 tons, of which 70 tons are available for adhesion. The

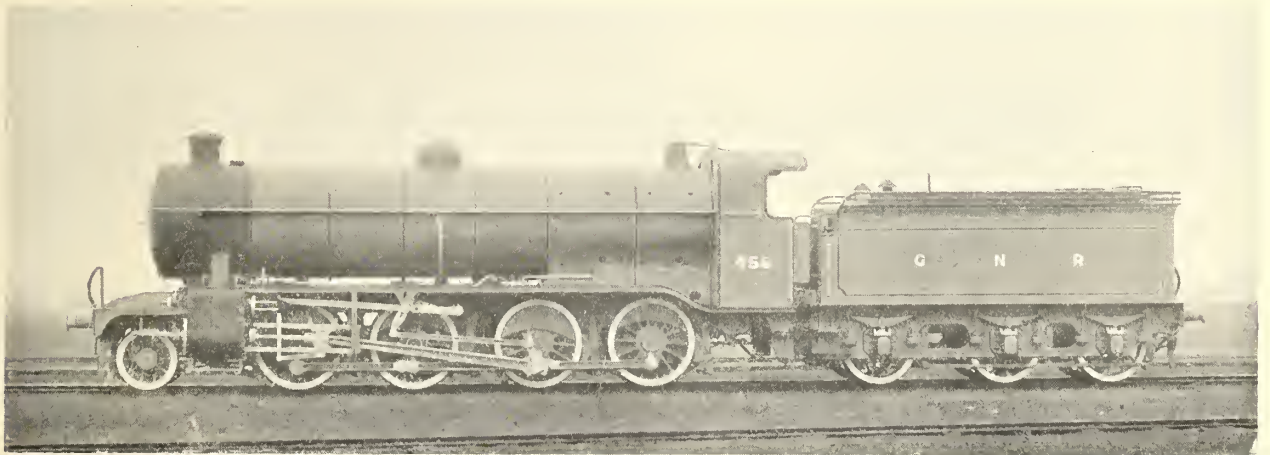

FIG. 445—H. N. GRESLEY'S 2-8-0 MINERAL TRAFFIC ENGINE, GREAT NORTHERN RLY., 1913

this country for a simple engine. The tires of the two middle pairs of coupled wheels were without flanges, but of increased width. Total wheel base, 24ft. 6in.; weight, 84 tons, of which 66 tons are

first of them came out in 1910 and was illustrated in *The Locomotive*, February 15th, 1911, and in *The Engineer*, January 1st, 1915.

The 2-8-2 tank engine is not represented on

British railways. It has the advantage of reducing flange wear of tires, at the expense of a smaller proportion of adhesive to total weight.

Steam Motor Coach Locomotives.—In 1903 there was a revival of the old W. Bridges Adams

its four wheels carried one end of the 8-wheeled combination. Most of the locomotives were of the 0-4-0 type, but the Taff Vale engines and those by Beyer, Peacock for the L.B. and S.C.R. and N.S.R. were of the 0-2-2 type with outside

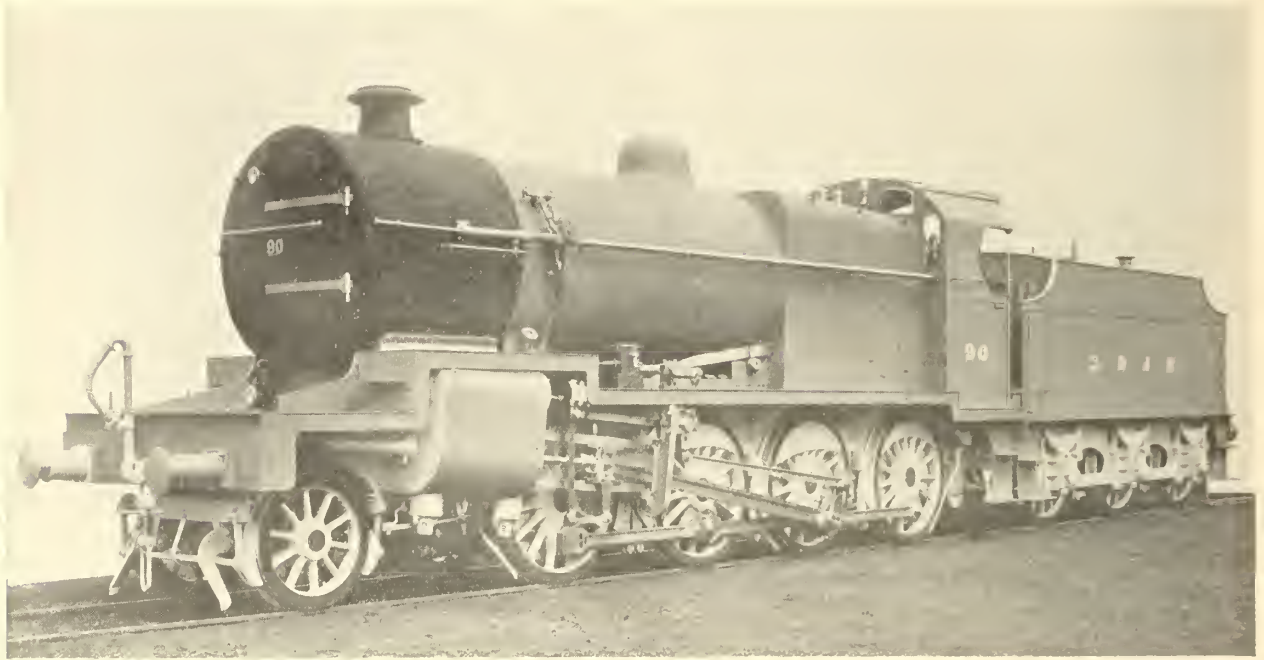

FIG. 446—SIR H. FOWLER'S EIGHT-COUPLED GOODS ENGINE, SOMERSET & DORSET JOINT RLY., 1925

steam rail cars, and D. Drummond placed one in service on the L. and S.W.R. between Fratton and Southsea. Most of the leading lines followed with various designs for light branches, some with vertical and others with locomotive type boilers. In those for the G.W.R. and L. and N.W.R. the engine and boiler were enclosed within the coach

cylinders and single driving axles. For a complete account, with dimensions and drawings, reference should be made to the paper read by T. H. Riches and S. B. Haslam before the Institution of Mechanical Engineers, October, 1906.

As loads increased, and one or two trailer cars had to be added, it was found necessary to use

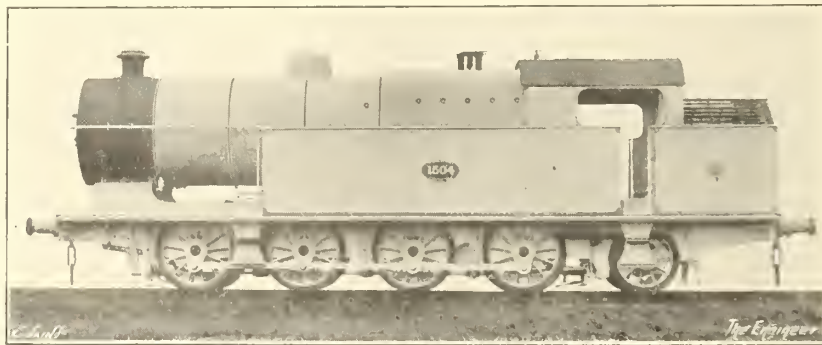

FIG. 447—G. HUGHES' LANCASHIRE & YORKSHIRE RLY. 0-8-2 BANKING ENGINE, 1908

at one end. In other cases, such as on the G.N.R. and L. and Y.R., and in Kitson's engines for the S.E. and C.R., the engine was placed outside the coach, to which it was attached in such a way that

independent locomotives, and several companies, notably the G.W.R., N.E.R. and L.B. and S.C.R., utilised existing small tank engines, which were sandwiched between ordinary bogie

carriages. The greater number of the original combined engines and cars have now been abandoned, though some are still in service.

LOCOMOTIVE DETAILS.

Boilers.—Following J. F. McIntosh's example of 1896, other engineers increased the diameter of boilers. Previously the size of the cylinders seems to have been the principal factor in estimating the power of a locomotive, but henceforth the boiler began to be the first consideration, though progress in this direction was gradual.

More attention was paid to water capacity, steam space, and circulation, and narrow water spaces were enlarged. Perhaps the most marked developments took place on the G.W.R. under Mr. Churchward's supervision. After W. Dean had adopted the Belpaire fire-box casing raised above the barrel, which was made in two rings, the

was made by Beyer, Peacock and Co. in 1907 for a four-wheeled industrial tank engine, built for the British Mannesmann Tube Co., Ltd., of Landore. This is illustrated by Fig. 448. The boiler consists of two cylindrical drums, connected by two openings somewhat after the style of the Flaman boiler introduced in 1892 on the Eastern Railway of France. The lower drum, 9ft. 6½in. long, and 3ft. 0¾in. diameter, contained 153 fire-tubes of 1¾in. diameter. The upper drum is longer, extending backwards to a point behind the fire-box, and is 2ft. 3¼in. diameter, its function being to receive the steam generated by the fire-box and tubes. In place of the ordinary inside fire-box, with water spaces, the fire-box casing contains 34 water tubes, each 3¼in. in diameter. These are fitted at their upper ends into the lower part of the steam drum, and thence they lead down round the interior of the fire-box casing

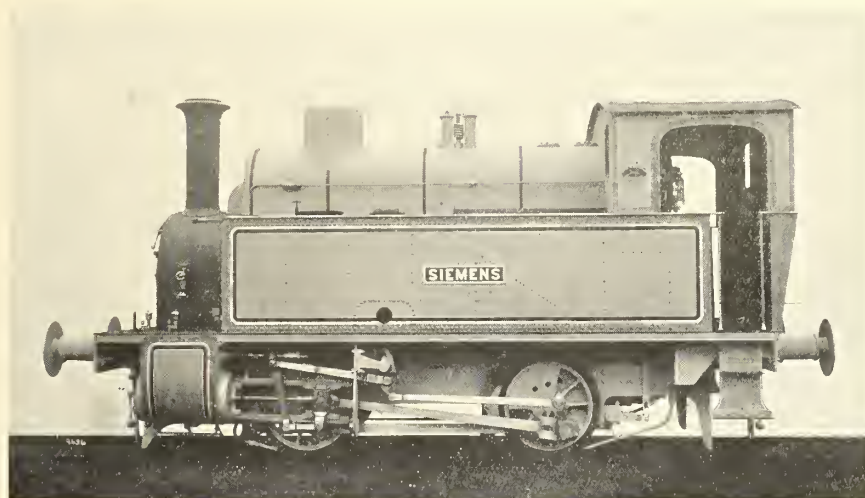

FIG. 448—BEYER, PEACOCK'S TANK ENGINE WITH BROTTAN WATER-TUBE FIRE-BOX, 1907

second ring was coned so that the top joined the fire-box casing and simplified the flanging necessary for the raised casing. This was another form of the American wagon top boiler. Afterwards the front ring was also coned. The design provided a greater area at the water line, larger steam space, and increased water space at the sides of the tubes.

On the L. and Y.R., H. A. Hoy in 1902 built a number of mineral engines with steel corrugated Cornish flues in place of copper fire-boxes.²⁷ The principle was similar to that of the Lentz boilers in Germany, and of the Vanderbilt type in the U.S.A. The design has been abandoned. Particulars of the service and defects of these boilers were given by Mr. G. Hughes, "Proc." Inst. Mech. Engineers, February, 1906, and July, 1909.

The only water-tube fire-box of the Brotan type

to a rectangular chamber which occupies the position of the foundation ring in an ordinary fire-box. This is a water chamber, circulation being provided through the tubes by means of an inlet on the front end of the chamber, which is connected with a man-hole on the under side of the boiler barrel. Thus there is a constant circulation of water from the lower part of the boiler to the fire-box ring, and thence up the water tubes. In use the water-tubes are surrounded by fireclay or similar material. The fire-box of the engine illustrated measures 4ft. 3¾in. long by 3ft. wide, and the heating surface is as follows:—Fire-box water-tubes 77 square feet, smoke-tubes 669 square feet, total 746 square feet; the grate area is 9.2 square feet, and the pressure carried is 180 lb. per square inch. Though this is the first British-built engine fitted with the Brotan boiler, a considerable number have been built for the Hungarian, Austrian and German railways.

²⁷ Drawings appeared in THE ENGINEER, August 15th, 1902.

In 1902 six passenger tank engines on the L. and Y.R. were provided with Druitt-Halpin's thermal storage system, consisting of a cylindrical vessel mounted above the boiler and connected to it by saddle plates. The object is to cause the excess of power generated in the boiler, over that required for immediate consumption, to be stored as steam and hot water for use when extra power is demanded. Drawings appeared in the "Proc." Inst. Mech. Eng., July, 1909. On a heavy road with frequent stopping places, the saving was stated by Mr. G. Hughes to be 12 per cent., but when the engines took their turn on other sections the all-round economy was 4 per cent.

Superheaters.—By far the most notable landmark in locomotive progress during the present century is high degree steam superheating. Sir John Aspinall's superheater of 1899, placed within a chamber recessed into the boiler barrel imme-

diately behind the smoke-box, produced a superheat up to 95 deg. Fah. From a modern standpoint it would be considered as a steam dryer; nevertheless it was a very efficient one. The practical application of high temperature superheating was due to Wilhelm Schmidt, of Cassel. His first two designs, which were tried in Germany in 1898 to 1900, were never used in this country. The present well-known form was applied by M. Flamme, in Belgium, and particulars were given in the "Proc." Inst. Mech. Eng., June, 1905. The first Schmidt superheaters on a British railway, as far as the writer can trace, were fitted by Mr. G. Hughes in November, 1906, to two goods engines on the L. and Y.R. They were followed by Mr. D. Earle Marsh's 4-4-2 express tank engines on the L.B. and S.C.R. early in 1908. The principle of Schmidt's smoke-tube superheater has been followed in various designs, such as the Robinson, Gresley, Swindon, East-

leigh, Horwich, etc., which have been illustrated in *The Engineer* and in the special supplement on "Locomotive Superheating and Feed Water Heating" to *The Locomotive Carriage and Wagon Review*. D. Drummond, on the L. and S.W.R., contented himself with a couple of short cast steel boxes in the smoke-box, forming a steam dryer, much less efficient than Aspinall's, as the superheat amounted to only about 20 deg. Fah. Other more elaborate forms of smoke-box superheater, such as the Phoenix, were tried, and abandoned.

Feed-water Heating.—F. H. Trevithick's classic experiments, from 1901 onwards, on the Egyptian State Railways,²⁸ led to a revival of feed-water heating and with it the use of independent feed pumps. Trevithick utilised both the exhaust steam and smoke-box heaters in series. Contemporaneously D. Drummond arranged under the tender tank a long cast iron box con-

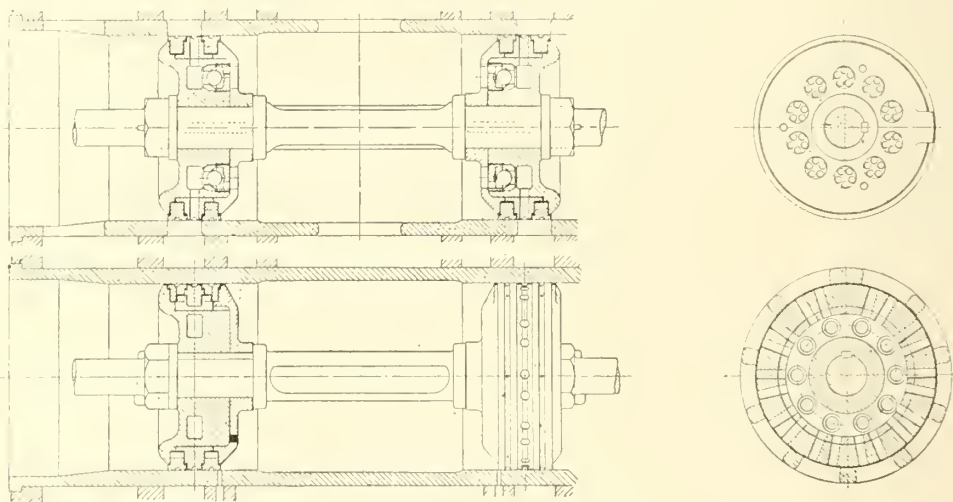

FIG. 49—G. HUGHES'S PISTON VALVE, L. & Y. RLY.

taining a series of pipes, into which the exhaust steam was turned. Subsequently he added a smoke-box coil in series with the tender heater.

Boiler Accessories.—The top feed through the steam space is of ancient origin. In 1863 G. Spencer patented a feed-water purifier. A chamber into which feed-water was admitted was in communication with the steam space and contained a number of trays, one below the other. The feed-water was delivered on to the top tray, whence it descended on to those below in series, finally falling through the steam space into the boiler. An almost similar arrangement was applied from 1863 onwards by Herr Wagner, locomotive engineer of the Bergisch-Märkische Railway, Germany, and was illustrated in *The Engineer*, January 16th, 1867. M. Chapsal applied a very similar arrangement in France about 1890. In this country the top feed had been forgotten until

²⁸ See *THE LOCOMOTIVE*, June—November, 1913.

history again repeated itself, and in the discussion on Mr. G. J. Churchward's paper on "Large Locomotive Boilers" (Inst. Mech. Eng., March, 1906), Mr. Vaughan Pendred suggested putting the feed into the steam space. Mr. Churchward then stated that he intended to pursue the plan, and the G.W.R. system of top feed resulted. The apparatus is similar to that of 1863, but instead of a second "dome" to contain the trays, in Churchward's design two parallel trays are placed inside the boiler under the safety valve seating, to the sides of which the clack boxes are fixed. The delivery pipes are external. In Mr. R. E. L. Maunsell's S.E. and C.R. engines of 1917 the dome-shaped chamber outside the boiler reappeared, and the water flows down a helical tray inside this chamber, finally dropping on to a saddle fixed to the perforated steam pipe.

Variable blast-pipes of different designs came more extensively into use. Several took the form of a cone which could be raised or lowered inside the orifice. These were regulated from the foot-plate, but in T. Whitelegg's London, Tilbury and Southend engines, built in 1909 by R. Stephenson and Co., the cone was actuated automatically when notching up by means of a bell-crank lever worked by a rod connected to the reversing gear through the medium of a slotted link. Blast-pipes with internal regulating cones are ancient history, and appear in Rothwell's engine of 1832—see Fig. 16 *ante*. They reappeared about forty years later on the Continent, where several designs were in use in Germany about 1870. After another long interval they found their way back to this country.

A most ingenious and successful automatic variable blast-pipe is the "jumper," applied by Mr. Churchward to the G.W.R. engines. This consists of a loose collar with a projection which rests upon a ledge on the outside of the orifice. The orifice has sixteen 1in. holes round its circumference, through which the excess of exhaust steam passes when the blast is heavy. This steam acts upon the top flange of the "jumper," which is lifted, thereby increasing the effective area of the orifice.

Various novel kinds of spark arresters appeared during the first few years of the present century. Their use till then had been very limited in this country, and the types employed had consisted of a wire gauze screen disposed either as a horizontal diaphragm across the smoke-box, or an inverted cone extending from the top of the blast-pipe to the base of the chimney. The new arresters took the form of baffle plates arranged in various ways in the smoke-box. In D. Drummond's arrester perforated baffle plates were fixed to movable wings hinged to the blast-pipe, so that they could be moved aside when the tubes were being cleaned. In McIntosh's arrangement a plate V-shaped in plan is fixed between the tube-plate and the blast-pipe, with the addition of an

inclined deflector plate, the latter being similar to the American "diaphragm" plate. Additional louvre baffles are fitted to the front of the smoke-box. To prevent accumulation of ashes in the angle of the V plate at the bottom of the smoke-box a 3in. draught pipe with its lower end near the base of the blast-pipe and its upper end in the bottom of the chimney is arranged inside the angle of the V plate. This system was applied to many of the Caledonian Railway engines.

Frames, Axles, Bogies, etc.—On the G.W.R. Mr. Churchward in 1903 adopted a composite frame, of which the front end consists of a -shaped slab, which is bolted to the main plate frame in front of the first coupled axle. The slab is similar to the form used in the latest American practice, being a compromise between a bar and a plate. It lends itself to the attachment of the outside cylinders, which, with their steam and exhaust passages, are in modern G.W.R. practice also based upon American designs.²⁹

Though not universally used, built-up crank axles with balance weights formed as extensions of the crank webs superseded forged crank axles for heavy engines on several railways. On the G.W.R. and the L. and Y.R. pendulum link bogies were abandoned. The former had tried the three-pin and the latter had used the two-pin arrangement of swing links. The spring-controlled sliding bogie proved that a much steadier riding engine resulted. The later G.W.R. bogie is a combination of British, French, and American features. It is of the sliding type controlled by two helical springs, as in R. Stephenson and Co.'s design of 1861. The weight is not carried on the pivot, but the Alsatian design is followed, in which the bearing of the main frame rests on a spherical seating at each side. Finally, the bogie frames are of the American bar construction. Incidentally these are the only bar frames in British railway practice, but a bar-framed bogie, somewhat similar to a diamond truck, has recently been supplied to one of the smaller "Atlantic" express engines of the G.N.R. type, "3990" class, on the L. and N.E.R. The axle-boxes and bearings are outside.

The bogies of the later N.E.R. engines are provided with Timmis's spiral bearing springs. Those of the leading wheels have a greater deflection per ton than those of the hind wheels, the respective rates for the 4-4-2 express engines being .535in. and .375in. per ton, the object being to make the front end adapt itself more readily to the inequalities of the track. This is, in effect, P. Stirling's idea of 1870 carried out in a different manner.

Brakes on leading-bogie wheels were adopted on the G.W.R. and subsequently on the Midland Railway, and they were also fitted to the L. and Y.R. 4-6-0 engines in 1908. Mr. Hughes, in his report to the 1922 Congress of the International

²⁹ See drawings in THE ENGINEER of May 13th, 1904.

Railway Association, stated that on the L. and Y.R. they were afterwards discarded as the "brake tended both to stiffen the bogie wheel base and impede the free rotation of the wheels, thus increasing the tendency for them to mount the rail. As one of the functions of the bogie is to guide the engine round curves, it was considered advisable to keep it as flexible as possible." There is considerable difference of opinion on this subject, and the G.W.R. and M.R. engines still retain bogie brakes.

A novelty in two-wheeled pendulum link pony trucks was introduced by Mr. H. N. Gresley on the G.N.R. in 1912.³⁰ The single bolster is replaced by a double one, the top portion being inverted. The object is to equalise the weight on the truck wheels when passing round curves; at the same time the lateral tilting of the body of the engine with a two-pin single pendulum bolster is avoided.

Cylinders and Valves.—After the 1849 experiment on the S.E.R., the uniflow system was not revived for locomotives until Stumpf took it up in Germany about 1909. The N.E.R. 4-6-0 engine with uniflow cylinders, illustrated by Fig. 440,³¹ was built in February of the same year. The weight, 71.7 tons, of the engine was 2.85 tons more than that of the otherwise similar standard engines.

The method of supporting the smoke-box in a saddle forming part of the cylinder casting, as has been the American practice for many years, was introduced by W. Dean on the G.W.R. at the end of 1899 for inside cylinders. In 1902 the design was used for the first G.W.R. 4-6-0 express engine, with outside cylinders, and has since gradually spread to other railways.

When the G.W.R. first tried piston valves, the old solid plug type was adopted, though it had been discarded many years previously. But to avoid trapped water spring-loaded relief valves were fitted to the cylinder covers. Eventually the plug valves were abandoned by the G.W.R., owing to leakage of steam past them.

The various designs of piston valves are too numerous to describe in great detail. The most original design is that of Mr. G. Hughes on the L. and Y.R., in which passages through the piston valve heads form communications between the cylinders and the steam chests. These passages are closed by steel balls, which are held on their seats by the steam chest pressure. When the back pressure in the cylinders rises above the steam chest pressure, the balls fall from their seats and relieve the former—see Fig. 449. Mr. J. G. Robinson's piston valve affects the same purpose by means of a flat annular valve, which covers a number of holes drilled circum-

ferentially through the head, corresponding holes being drilled radially through the solid ring, the latter registering with a third series of holes in the main packing ring. The annular valve opens the passages through the holes when the pressure in the cylinders is in excess of that in the steam chest. Both these piston valves do away with the necessity for release valves on the cylinder covers.

Motion and Valve Gears.—In 1902 the G.W.R. provided the connecting-rods of the first outside cylinder 4-6-0 engine with big ends having solid bushes, and all the standard engines with outside cylinders have this form of rod, which has spread to several other railways.

Deeley's valve gear has already been mentioned. A valve gear by J. T. Marshall, of Leeds, was fitted in 1902 to a Great Northern goods engine, and subsequently to a 4-4-0 passenger engine. Unlike many other valve gears, in which at least one excentric is suppressed, two excentrics were used.³²

In 1912 Mr. H. N. Gresley adopted a modification of the usual form of Walschaerts gear. The weight of the combination lever and the front end of the radius rod is carried by a small cross-head, which slides in an extension of the back cylinder cover. This arrangement replaced the valve spindle tail rod and its guide. The back end of the radius rod, instead of being connected by a link to an arm of the reversing shaft, is extended to a point behind the quadrant link and carried on a slipper block attached to an arm at the end of the reversing shaft. This arrangement reduces the slip of the block in the quadrant link. Subsequently, Mr. Gresley applied ball bearings to the return crank.

To the G.N.R. "Atlantic" engines, which have a reversing lever with notched sector, H. A. Ivatt in 1900 applied an arrangement to maintain the reversing shaft rigid, and prevent the rattling movement which frequently occurs. A small friction drum in halves is keyed to the reversing shaft. On the back of the cross stay is fastened a cast iron strap, which embraces half the circumference of the drum. The movable portion of the strap, embracing the other half circumference, is of wrought iron and is tightened by means of a link and lever attached to the piston-rod of a 6in. vacuum cylinder.

The adoption of superheating made it necessary to pay particular attention to the lubrication of cylinders and valves, and mechanical lubricators became extensively used, though on several railways sight-feed lubrication continued to be quite efficient. Without making any definite statement, the writer thinks that mechanical lubricators were first used in Germany, where several forms were to be found at the beginning of this century.

³⁰ Shown in the drawings of the 2-6-0 engine in *THE ENGINEER* of November 28th, 1913.

³¹ Drawings appeared in *THE ENGINEER*, April 18th, 1913.

³² A full description of the gear, as fitted to a 4-4-0 engine on the G.S. and W.R., Ireland, was given in *THE ENGINEER*, November 3rd, 1905.

Chapter XXIII—1914-25

LOCOMOTIVE developments within the final period from the beginning of the war until the end of 1925 are well within the memories of those interested, and, moreover, almost every engine of importance has been described and illustrated in the engineering journals. Therefore it will be sufficient to tabulate the dimensions of the principal classes. The following brief comments draw attention to salient features.

Express Passenger Engines.—Table XVII gives dimensions of express engines of the 4-4-0, 4-6-0 and 4-6-2 types. Of the five 4-4-0 engines only Nos. 1 and 2 were entirely new, the others were “reconstructed.” The two Highland engines (2) are the only 4-4-0 locomotives in the country with outside Walschaerts valve motion. One is illustrated by Fig. 450. The London and

cast with a saddle, remain 19in. by 26in. as before.

The Glasgow and South-Western engine (5) is practically new, and is the only 4-4-0 engine with four high-pressure cylinders—Fig. 451.

Of the 4-6-0 engines, Nos. 6, 8 and 10 have two cylinders. Those of the L. and S.W.R. engines (8), 22in. by 28in., are the largest in this country—Fig. 452. These and the Highland engines (10) have outside Walschaerts valve gear—Fig. 453. The Caledonian engines (11) have three cylinders, of which the two outside drive the second coupled axle, and the single inside cylinder drives the front coupled axle. The Walschaerts valve gear is outside, and the valves of the central cylinder are driven by a floating lever arrangement. Engines Nos. 7, 9, 12 and 13 have four cylinders. The G.C.R. engines (7) have valves

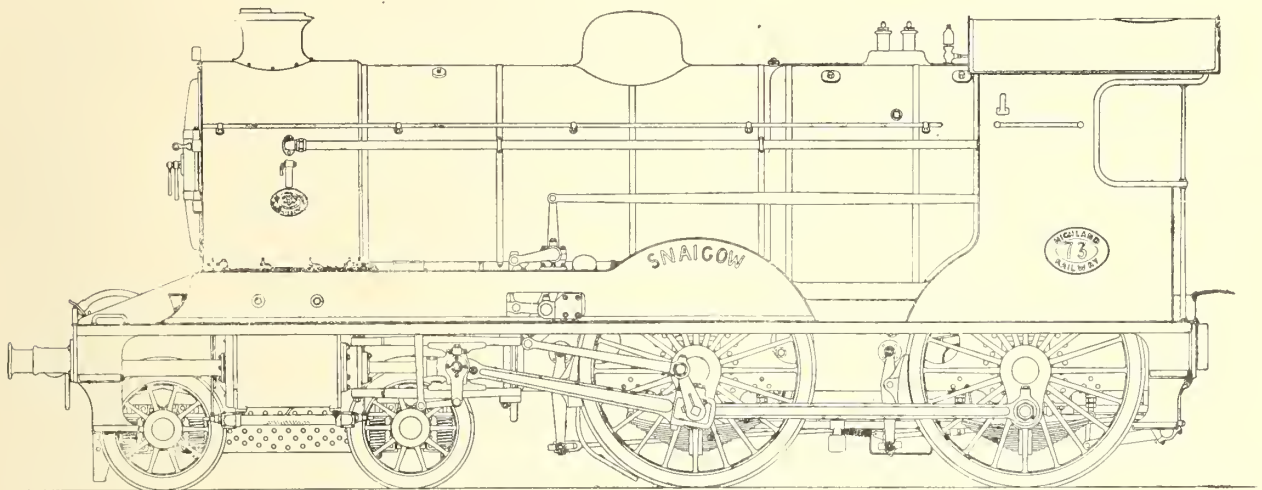

FIG. 450—C. CUMMING'S PASSENGER ENGINE, HIGHLAND RLY., 1916

South-Western Railway engines (3) were D. Drummond's "463" class of 1911, to which Mr. Urie added Eastleigh superheaters, at the same time removing the fire-box water-tubes. Many of Drummond's engines were similarly altered. The S.E. and C.R. engines, "179" class (4) are superheated engines reconstructed by Mr. R. E. L. Maunsell from a type previously using saturated steam, which worked the Dover express traffic over the "Chatham" section of the railway. As they already weighed about the maximum permissible, the problem was to reconstruct the engines so that this weight was not materially exceeded. Actually the excess was only $\frac{1}{4}$ ton. The weights on the driving and trailing wheels were decreased by 0.1 tons and 1.3 tons respectively, and that on the bogie increased by 1.65 tons. The new cylinders,

driven by inside Stephenson's link motion actuating the bottom lever arm of a rocking shaft, of which the two upper arms, working in synchronism, are attached to the valve spindles of the inside and outside cylinders respectively. Since the cranks on each side are at 180 deg., the valves of the inside cylinders have inside admission and those of the outside cylinders outside admission. The Lancashire and Yorkshire Railway engines (9), now the standard 4-6-0 engine of the L.M.S.R., have outside Walschaerts valve gear, the valves of the inside cylinders being driven by rocking levers behind the cylinders—Fig. 454. The cylinders, 16 $\frac{1}{2}$ in. by 26in., are the largest now in use for a four-cylinder non-compound engine. The drive is divided between the first two coupled axles. The Irish engine for the Great Southern and Western Railway (12) is

somewhat similar, but the outside cylinders are placed further back and the inside cylinders further forward, so that the rocking levers are actuated by the front tail rods of the outside valve spindles. It is shown by Fig. 455. The Great

the *Locomotive Railway Carriage and Wagon Review* that only a few salient features need be mentioned here. The boiler is the largest in this country, and has an outside diameter of 5ft. 9in. at the front ring, increasing in the second ring to



FIG. 451—FOUR CYLINDER EXPRESS ENGINE, GLASGOW & SOUTH-WESTERN RLY., REBUILT BY R. H. WHITELEGG, 1923

Western Railway engine (13) of the "Caerphilly Castle" class is generally similar to the earlier "Star" class, but has larger cylinders and a much larger boiler. It is illustrated by Fig. 456. The tractive effort of the "Castle" class is 31,700 lb., and that of the "Star" class 27,000 lb. The coal consumption of the former is considerably less, to the extent of $3\frac{1}{2}$ lb. per mile. A dynamometer test, the figures of which were given by Mr. Collett at the 1924 World Power Conference, showed 2.1 lb. of coal per I.H.P. hour and 2.83 lb. per D.H.P. hour; mechanical efficiency of the engine 74 per cent., thermal

6ft. 5in. at the fire-box. The top portion of the fire-box extends towards the barrel, thereby forming a combustion chamber. The combined length of the fire-box and chamber is 7ft. 11 $\frac{3}{4}$ in., the grate being 5ft. 10 $\frac{11}{16}$ in. long by 6ft. 11 $\frac{3}{4}$ in. wide. The tubes have a length of 19ft. The inside cylinder is placed further back than the outside cylinders, and is inclined at 1 in 8. All three drive the middle coupled axle. The connecting-rods have bushed ends, and the valve gear is Walschaerts, placed outside, driving the third inside valve through Gresley's floating lever gear. The trailing axle is radial, with outside axle-boxes

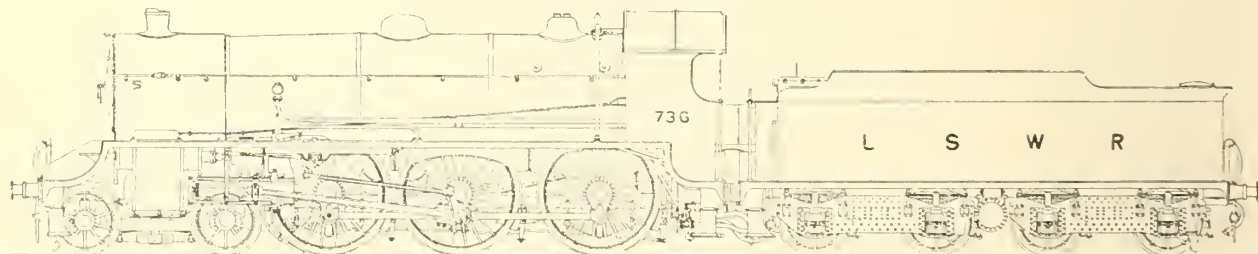

FIG. 452—R. W. URIE'S EXPRESS ENGINE, LONDON & SOUTH-WESTERN RLY., 1918

efficiency of boiler, 79.8 per cent.; thermal efficiency = $\frac{\text{work in cylinders}}{\text{heat in coal}} = 8.22$ per cent.

The coal burnt per ton-mile was 0.101 lb.

Mr. H. N. Gresley's three-cylinder "Pacifics" (14) for the Great Northern Railway—Fig. 457—have been so fully described in *The Engineer* and

having inclined planes. These engines have now been adopted as the standard heavy express locomotives of the London and North-Eastern Railway.

The North-Eastern "Pacific" (15), designed by Sir Vincent Raven and shown by Fig. 458, differs from the Great Northern in that all three

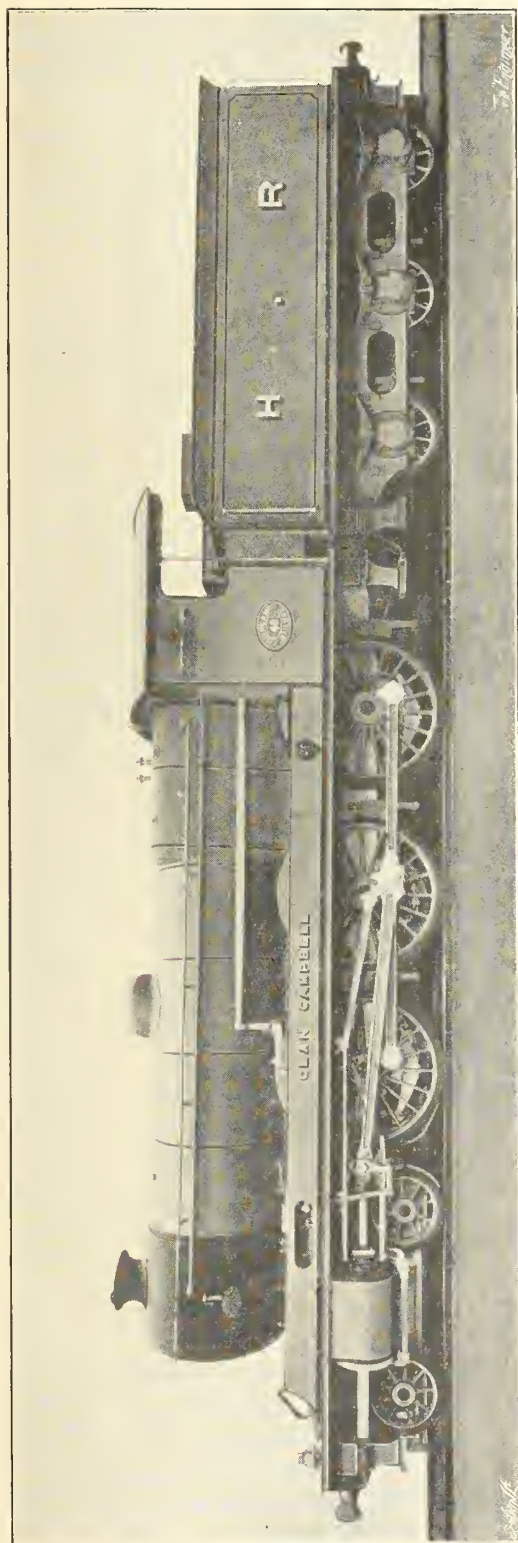

FIG. 433—C. CUMMING'S 4-6-0 EXPRESS ENGINE, BUILT BY R. & W. HAWTHORN, LESLIE & CO., LTD., 1918

cylinders are in line and drive the first coupled axle. This produces an extremely long engine, with a total wheel base 1ft. 5in. more than that of the G.N. The trailing radial axle has inside bearings in the case of the first two engines, but in the three later engines outside bearings are provided.

Of the express engines, Nos. 1 to 15, in the table, the majority were built at the railway companies own works. The Highland engines (Nos. 2 and 10) were by R. and W. Hawthorn, Leslie and Co., Ltd., and a number of the Caledonian engines (No. 1) were by the North British Locomotive Company, Ltd., and Armstrong, Whitworth and Co., Ltd. The latter firm also built six of the Great Southern and Western (Ireland) engines (12). For the L. and N.E.R. the North British Locomotive Company, Ltd., has supplied twenty of Mr. Gresley's 4-6-2 engines (No. 14).

An engine not mentioned in the table is the "Atlantic" express locomotive built by the N.E.R. at Darlington in 1917 with three uniflow cylinders, 16½in. by 26in. and 6ft. 10in. coupled wheels. This engine weighs 79.2 tons, or 2.5 tons more than the standard three-cylinder engines of the 4-4-2 type. It is the only uniflow locomotive still at work (September, 1925), the other N.E.R. engine—Fig. 440—having been converted to the ordinary type.

Mixed Traffic, Goods, and Mineral Engines.—The following notes refer to engines Nos. 1 to 13 in Table XVIII.

The G.E.R. engine (No. 1) is the largest of the 0-6-0 type hitherto constructed. The distance between the driving and trailing wheels is 10ft. The Great Northern (Ireland) engine (No. 2) is shown by Fig. 459, as an excellent example of the latest type of large 0-6-0 goods engine. These Irish engines were built by Beyer, Peacock and Co., Ltd.

Of the S.E. and C.R. engines (No. 3), one was built in 1922 with three 16in. by 28in. cylinders. The outside valves above the cylinders are driven directly by Walschaerts valve gear. The inside valve is placed on the left-hand side of the central cylinder and is driven by a system of horizontal levers situated behind the front buffer beam. These levers are actuated on both sides of the engine by long external rods, the back ends of which are attached to short vertical levers, the latter being moved by the valve spindles of the outside cylinders. The rod on the right-hand side moves a long transverse horizontal lever, with a fixed fulcrum, the arms being in the ratio of 7 to 3. The left-hand rod moves a short lever, the other end of which is connected to the front of the valve spindle of the middle cylinder. The arms of this lever are in the ratio of 4 to 3, its floating fulcrum being attached to the near or shorter armed extremity of the long lever. The object of the arrangement is to avoid the trans-

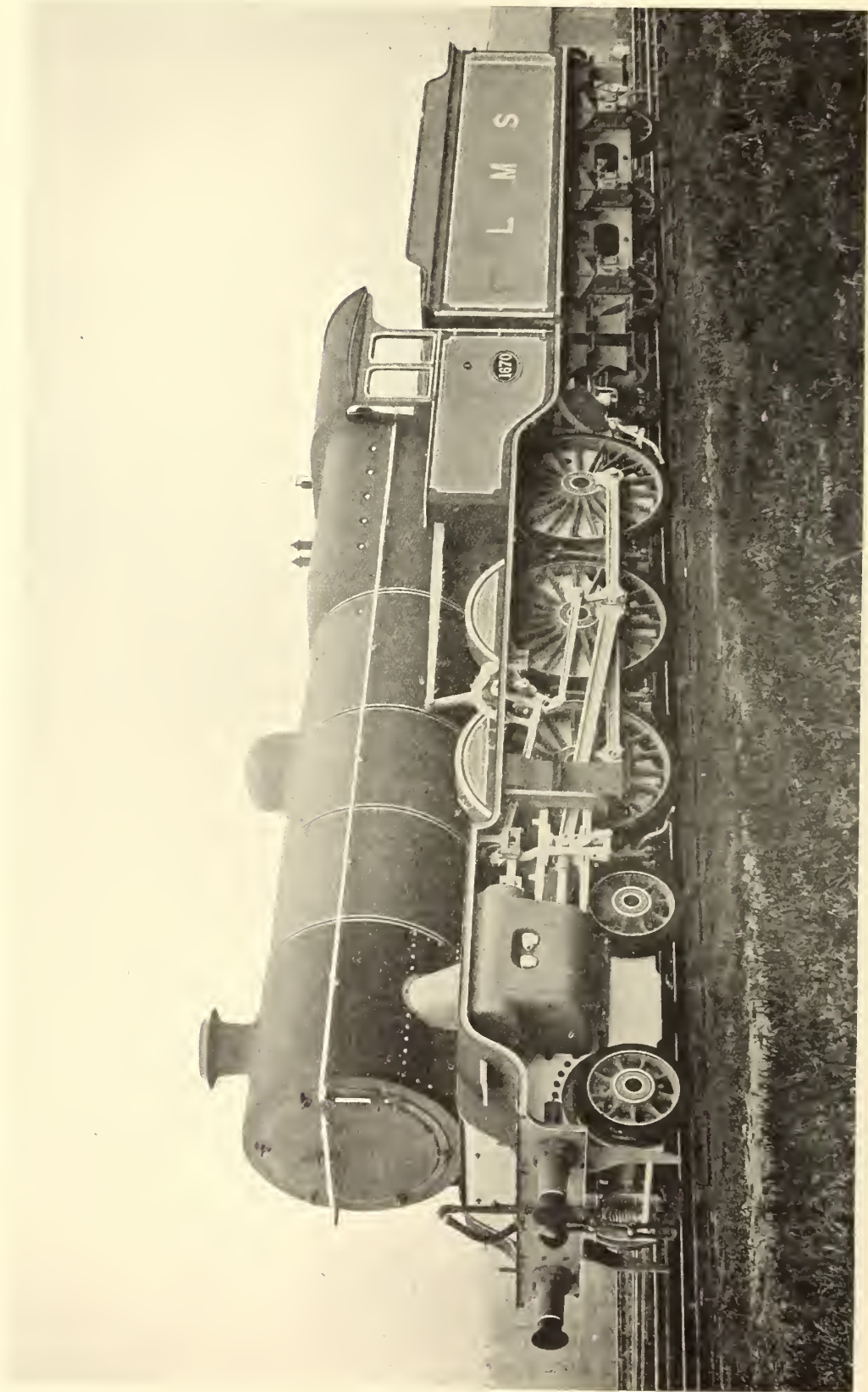

FIG. 654-G. HUGHES'S FOUR-CYLINDER ENGINE, LONDON, MIDLAND & SCOTTISH RLY. (FORMERLY LANCASHIRE & YORKSHIRE RLY.), 1921

TABLE XVII.—British Express Engines, Period 1915 to 1925.

Railway.	Designer.	Date.	Type.	Cylinders. i=inside. o=outside.	Driving wheels.	Wheel base.		Evaporative heating surface.			Super-heater surface.	Gratic area.	Pressure, lb. per sq. in.	Weight in working order.		Illustrations.
						Coupled.	Total.	Tubes.	Fire-box.	Total.				On coupled wheels	Total.	
1 C.R.	W. Pickersgill	1922	4-4-0	20 $\frac{1}{2}$ " \times 26", i	dia. 6' 6"	9' 9"	24' 4"	sq. ft. 1185	sq. ft. 141	sq. ft. 200	sq. ft. 20.7	180	tons. 39.75	tons. 61.25		
2 H.R.	C. Cumming	1916	4-4-0	20" \times 26", o	6' 3"	8' 9"	22' 11 $\frac{1}{2}$ "	1016	124	1140	180	160	34.24	54.97	Fig. 450	
3 L. & S.W.R.	R. W. Urie	1915*	4-4-0	20" \times 26", i	6' 7"	10' 0"	24' 9"	1139.5	144.5	1284	231	180	37.55	59.15		
4 S.E. & C.R.	R. E. Maunsell	1919*	4-4-0	19" \times 26", i	6' 6"	9' 6"	23' 6 $\frac{1}{2}$ "	1149.8	127.1	1276.9	228	24	33.5	52.5		
5 G. & S.W.R.	R. H. Whitelegg	1923*	4-4-0 (4-cyl.)	14" \times 24", o 14" \times 26", i	6' 9 $\frac{1}{2}$ "	10' 0"	24' 6"	1443.4	148	1591.4	211	180	38.9	61.45	Fig. 451	
6 C.R.	W. Pickersgill	1916	4-6-0	20" \times 26", o	6' 1"	14' 6"	27' 6"	1329.5	146.5	1676	258.2	170	56.5	75.0		
7 G.C.R.	J. G. Robinson	1917	4-6-0	16" \times 26" (4)	6' 9"	15' 6"	28' 10"	1881	159	2040	343	26	57.15	77.9		
8 L. & S.W.R.	R. W. Urie	1918	4-6-0	22" \times 28", o	6' 7"	14' 6"	27' 6"	1716	162	1878	308	180	55.95	77.85	Fig. 452	
9 L. & Y.R.	G. Hughes	1921	4-6-0	16 $\frac{1}{2}$ " \times 26" (4)	6' 3"	13' 7"	25' 7"	1511	175	1686	522	180	59.3	79.05	Fig. 454	
10 H.R.	C. Cumming	1918	4-6-0	21" \times 26", o	6' 0"	14' 0"	25' 9"	1328	139	1467	256	170	45.5	62.25	Fig. 453	
11 C.R.	W. Pickersgill	1921	4-6-0	18 $\frac{1}{2}$ " \times 26" (3)	6' 1"	15' 0"	28' 8"	2200	170	2370	270	28	60.0	81.0		
12 G.S. & W.R. (Ireland)	E. A. Watson	1921	4-6-0	14" \times 26" (4)	6' 7"	15' 3"	27' 1"	1614	158	1772	366	175	—	72.5	Fig. 455	
13 G.W.R.	C. B. Collett	1923	4-6-0	16" \times 26" (4)	6' 8 $\frac{1}{2}$ "	14' 9"	27' 3"	1885.6	163.7	2049.3	262.6	225	58.85	79.85	Fig. 456	
14 G.N.R.	H. N. Gresley	1922	4-6-2	20" \times 26" (3)	6' 8"	14' 6"	35' 9"	2715	215	2930	525	180	60.0	92.45	Fig. 457	
15 N.E.R.	Sir V. Raven	1922	4-6-2	19" \times 26" (3)	6' 8"	15' 0"	37' 2"	2211.2	211	2422.2	695.6	200	60.0	97.0	Fig. 458	

* Reconstructed engines.

TABLE XVIII.—Mixed Traffic, Goods, and Mineral Tender Engines, 1915 to 1925.

1 G.E.R.	A. J. Hill	1920	0-6-0	20" \times 28", i	4' 11"	18' 10"	18' 10"	1489.1	143.5	1632.6	286.4	26.5	180	—		Fig. 459
2 G.N.R. (Ireland)	G. T. Glover	1920	0-6-0	19 $\frac{1}{2}$ " \times 26", i	5' 1"	16' 11"	16' 11"	1134	132.8	1246.8	333	22.9	175	53.6		
3 S.E. & C.R.	R. E. Maunsell	1917	2-6-0	19" \times 28", o	5' 6"	15' 6"	24' 4"	1390.6	135	1525.6	203	25	200	50.9	59.4	
4 G.N.R.	H. N. Gresley	1920	2-6-0	18 $\frac{1}{2}$ " \times 26" (3)	5' 8"	16' 3"	25' 2"	1719	182	1911	527	28	180	60	71.7	
5 L. & S.W.R.	R. W. Urie	1920	4-6-0	21" \times 28", o	5' 7"	13' 9"	26' 7 $\frac{1}{2}$ "	1716	162	1878	308	30	180	55.9	76.95	
6 N.E.R.	Sir V. Raven	1919	4-6-0	18 $\frac{1}{2}$ " \times 26" (3)	5' 8"	13' 6"	27' 8"	1397.9	166	1563.9	530.1	27	180	58.7	77.7	
7 G.C.R.	J. G. Robinson	1921	4-6-0	16" \times 26" (4)	5' 8"	14' 5"	28' 3"	1881	163	2044	343	26	180	58.5	79.5	Fig. 445
8 N.E.R.	Sir V. Raven	1919	0-8-0	18 $\frac{1}{2}$ " \times 26" (3)	4' 7 $\frac{1}{2}$ "	18' 6"	18' 6"	1397.9	166	1563.9	530.1	27	180	71.6	71.6	
9 G.N.R.	H. N. Gresley	1921	2-8-0	18 $\frac{1}{2}$ " \times 26" (3)	4' 8"	18' 6"	17' 2"	1868.5	163.5	2032	430.5	27.5	180	67.35	75.8	
10 G.C.R.	J. G. Robinson	1918	2-8-0	21" \times 26", o	4' 8"	17' 1"	25' 5"	1641	174	1815	308	26	180	67.9	75.2	
11 G.W.R.	G. J. Churchward	1919	2-8-0	19" \times 30", o	5' 8"	20' 0"	29' 3"	2062.35	169.75	2232.1	323.9	30.28	225	73.4	82.0	Fig. 460
12 L. & N.E.R.	H. N. Gresley	1925	2-8-2	20" \times 26" (3)	5' 2"	18' 6"	36' 2"	2715	215	2930	525	41.25	180	71.5	100.0	Fig. 461
13 M.R.	Sir H. Fowler	1919	0-10-0 (bank g)	16 $\frac{1}{2}$ " \times 28" (4)	4' 7 $\frac{1}{2}$ "	20' 11"	20' 11"	1560	158.25	1718.25	445	31.5	180	73.07	73.07	Fig. 462

TABLE XIX.—British Tank Engines, 1914 to 1925.

Railway.	Designer.	Date.	Type.	Cylinders. i=inside, o=outside.	Driving wheels, dia.	Wheel base.		Evaporative heating surface.		Super- heating surface.	Grate area.	Boiler pressure, lb.	Weight in working order.		Tank capacity.	Illustrations.
						Coupled	Total.	Tubes.	Fire-box				Total.	On coupled wheels.		
1 N.B.R.	W. P. Reid	1915	4-4-2	19" x 24", 1	5' 9"	8' 3"	28' 11 1/2"	sq. ft. 930	sq. ft. 95	sq. ft. 1025	sq. ft. 16.6	lb. 165	37.33	73.3	gallons 2080	
2 Metropolitan	C. Jones	1920	4-4-4	19" x 24", 1	5' 9"	7' 9"	33' 6"	1046	132	1178	21.4	160	39.0	77.0	2000	Fig. 467
3 G.E.R.	A. J. Hill	1914	0-6-2	18" x 24", 1	4' 10"	16' 3"	23' 0"	1076.3	113	1189.3	17.7	180	49.22	61.6	1600	Fig. 463
4 G.N.R.	H. N. Gresley	1920	0-6-2	19" x 26", 1	5' 8"	16' 3"	23' 9"	880	118	998	19	170	55.75	70.25	2000	
5 N.S.R.	I. H. Adams	1916	0-6-4	20" x 26", 1	5' 6"	16' 0"	27' 9"	887	129	1016	21	160	55.5	74.1	2250	
6 S.E. & C.R.	R. E. L. Maunsell	1917	0-6-4	19" x 25", 0	6' 0"	15' 0"	35' 10"	1390.6	135	1525.6	20.3	200	52.75	82.6	1800	Fig. 465
7 C.R.	W. Pickersgill	1917	4-6-2	19 1/2" x 26", 0	5' 9"	13' 3"	33' 1"	1393	121	1516	22.0	170	55.05	91.65	2000	Fig. 471
8 Furness	Kitson & Co.	1920	4-6-4	19 1/2" x 26", 1	5' 8"	13' 3"	45' 0"	1850	153	2003	26	170	54.9	93.25	2200	Fig. 466
9 G. & S.W.R.	R. H. Whitelegg	1922	4-6-4	22" x 26", 0	6' 0"	13' 2"	39' 0"	1574	156	1730	30	180	54.0	99.07	2400	Fig. 473
10 L.M. & S.R.	G. Hughes	1924	4-6-4	16 1/2" x 26" (4)	6' 3"	13' 7"	40' 4"	1817	180	1997	29.6	180	56.5	99.95	2000	
11 N.S.R.	J. A. Hookham	1922	0-6-0	15" x 24" (4)	4' 6"	16' 6"	16' 6"	750	106.7	856.7	17.5	160	56.65	56.65	900	Fig. 469
12 G.C.R.	J. C. Robinson	1914	2-6-4	21" x 26", 1	5' 1"	17' 0"	37' 6"	1386	137	1523	26	180	58.75	96.4	3000	Fig. 464
13 L. & S.W.R.	R. W. Urie	1921	4-6-2	21" x 28", 0	5' 7"	15' 0"	36' 6"	1267	130	1406	27	180	59.0	96.4	2000	Fig. 468
14 L. & S.W.R.	R. W. Urie	1921	4-8-0	22" x 28", 0	5' 7"	18' 0"	37' 0"	1267	139	1406	27	180	—	—	—	Fig. 468
15 G.S. & W.R. (Ireland)	E. A. Watson	1915	4-8-0	19 1/2" x 26", 1	4' 6 1/2"	15' 3"	29' 1 1/2"	1426.7	138.5	1565.2	24.8	175	62	80	1500	Fig. 472
16 L.M. & S.R.	H. P. Beames	1923	0-8-4	20 1/2" x 24", 1	4' 5 1/2"	17' 3"	20' 3"	—	—	1687.4	23.6	185	66.5	88	2030	Fig. 470

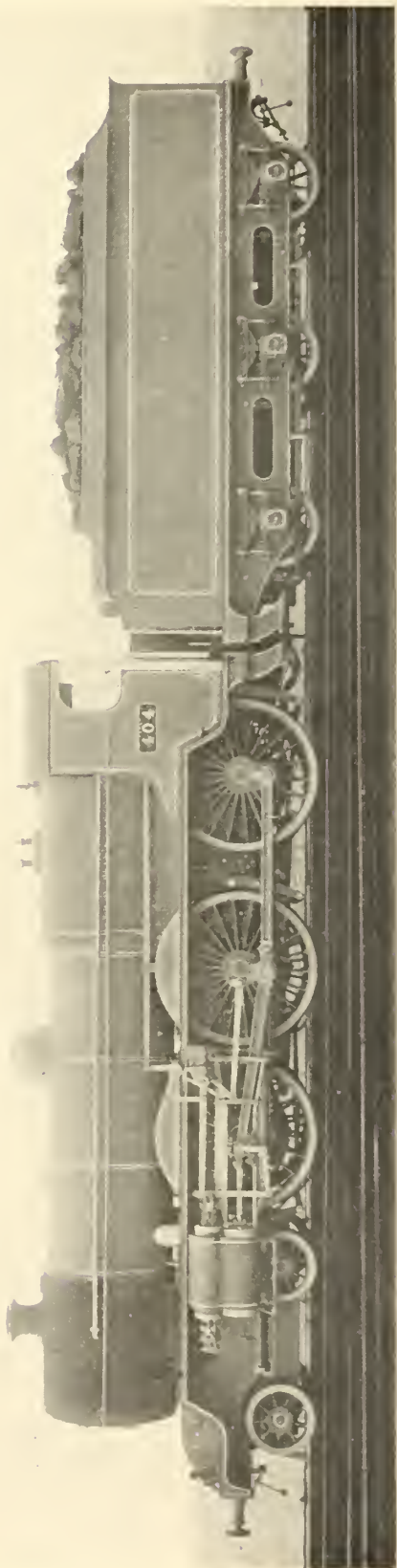

FIG. 455.—E. A. WATSON'S FOUR-CYLINDER 4-6-0 EXPRESS ENGINE, GREAT SOUTHERN & WESTERN RLY. (IRELAND), 1921

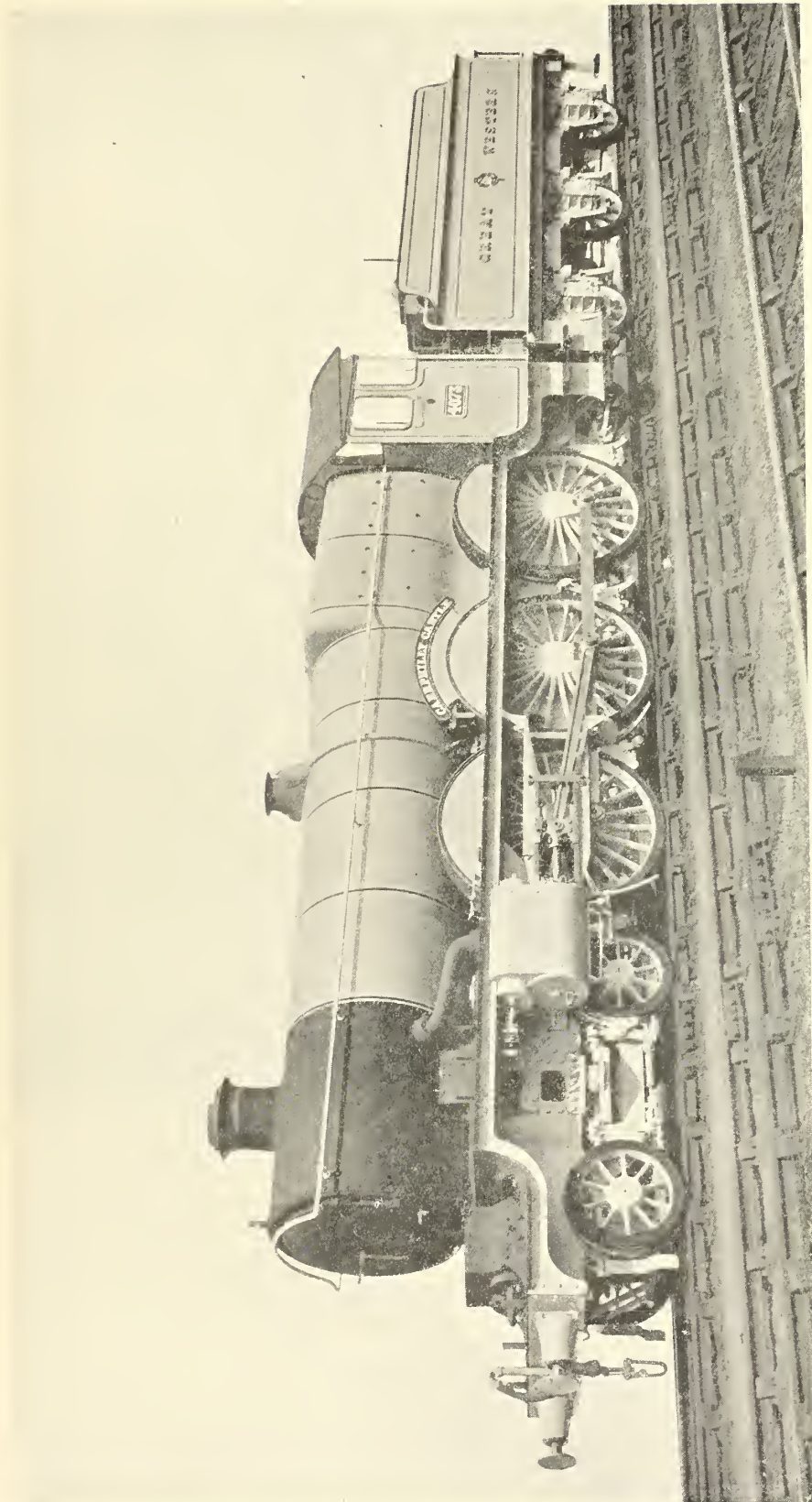

FIG. 456-C. B. COLLETT'S FOUR-CYLINDER 4-6-0 EXPRESS ENGINE, GREAT WESTERN RLY., 1923

ference to the middle valve of the effects of variations due to the expansion of the outside valve spindles, and also to allow the inside piston and all the piston valves to be removed without taking down any of the gear. The outside cylinders are horizontal, but the inside cylinder is inclined at 1 in 8, and the middle crank is at 113 deg. with the right and at 127 deg. with the left-hand crank.¹

The above arrangement of lever valve gear for three-cylinder locomotives is due to Mr. H. Holcroft, who patented it before Mr. Gresley's gear (which was designed independently) appeared. The Caledonian engines (11) have a very similar valve gear.

similar to the express engine (No. 7, Table XVII).

The G.W.R. engine (No. 11) is the only eight-coupled "mixed traffic" engine in the country. The first engine was built in 1919, but a larger boiler has since been provided, as shown on the drawing, Fig. 460, and to which the dimensions given in Table XVIII refer. The drive is on the second coupled axle and the ratio of connecting-rod to crank length is $5\frac{1}{2}$.

Mr. Gresley's 2-8-2 tender engine is illustrated by Fig. 461. This is practically a development of the three-cylinder 2-8-0 mineral engine used on the Peterborough-London coal trains, but with the boilers, cylinders and motion of the L.N.E.R. standard Pacific type passenger engines. These



FIG. 457—H. N. GRESLEY'S THREE-CYLINDER "PACIFIC" TYPE EXPRESS ENGINE, GREAT NORTHERN RLY., 1922

The G.N.R. engines (Nos. 4 and 9) have outside Walschaerts valve gear and Gresley's floating lever gear for the inside valve. In the 2-6-0 engine (No. 4), all three cylinders drive the middle coupled axle, and in the 2-8-0 and 2-8-2 engines (Nos. 9 and 12), all drive the second coupled axle.

The N.E.R. engines (Nos. 6 and 8) have inside Stephenson's link motion and six excentrics. The drive of all three cylinders is on to the first coupled axle of the 4-6-0 and on the second axle of the 0-8-0 engine.

The G.C.R. 4-6-0 engine (No. 7) is generally

¹ An outside view of this three-cylinder engine appeared in THE ENGINEER of February 23rd, 1923.

engines will work trains of approximately 1600 tons. With the exception of the L. and N.E.R. Garratt engine, Fig. 400 *ante*, No. 2393 is the most powerful locomotive in the British Isles, the total tractive power, with the booster in operation, being 47000 lb.

The coupled wheels are 5ft. 2in. diameter; the three cylinders are 20in. diameter by 26in. stroke. The booster engine, which has been added to the trailing pair of wheels (3ft. 8in. diameter) to enable the engine to start quickly, and also assist on the long grades of 1 in 200, has two cylinders 10in. diameter by 12in. stroke. Its tractive effort is 8500 lb.

The boiler has a maximum diameter of 6ft. 5in.

and a length of 19ft.; the working pressure is 180 lb. per square inch. The heating surface of the fire-box is 215 square feet; small tubes, 1880 square feet; flues, 835 square feet; total evaporative surface, 2930 square feet; superheater, 32 elements, 1 $\frac{1}{4}$ in. diameter inside, heating surface, 525 square feet; total heating surface, 3455 square feet.

The Midland engine (No. 13), Fig. 462, is the only ten-coupled locomotive in the country, the G.E.R. heavy tank engine having disappeared. Although intended for banking trains up the Lickey incline, a tender and not a tank engine was built, since the weight of the latter would have been too great. As built, the axle load does not exceed 15.5 tons, and the weight per foot run of wheel base is 2.29 tons. The tractive force at 80 per cent. of boiler pressure is 18.2 tons. Walschaerts outside valve gear is used, and the two

cylinder passenger engine (No. 6), shown by Fig. 465, and the G.C.R. inside cylinder mineral engine No. 12. Of the engines with a bogie at each end, only one, the 4-6-4 engine (No. 8), for the Furness Railway, has the wheel base symmetrically arranged, the distance from the bogie centre to the nearest coupled axle being 10ft. 3in. at each end. The Furness Railway engine is shown by Fig. 466. In the other 4-6-4 engines, Nos. 9 and 10, the trailing bogie centre is further away from the trailing coupled axle than the leading bogie centre from the front coupled axle. In the Metropolitan 4-4-4 engine the opposite is the case, as shown by Fig. 467. All the 4-6-4 tank engines have bogies of 7ft. wheel base.

All the main line tank engines, both passenger and goods, are superheated, with the exception of the Furness 4-6-4 tank engines, for which the railway company preferred to use saturated steam.

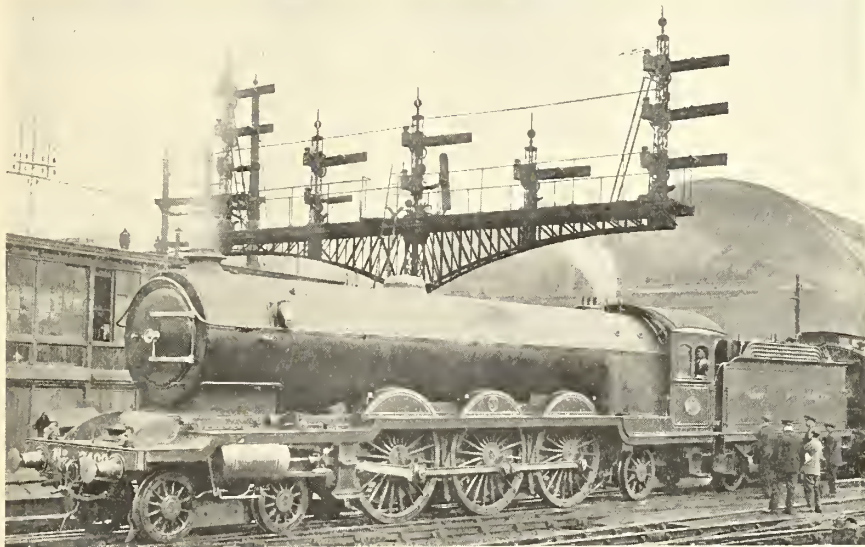

FIG. 458—SIR VINCENT RAVEN'S THREE-CYLINDER 4-6-2 EXPRESS ENGINE, NORTH-EASTERN RLY., 1922

piston valves for the four cylinders have outside admission, the ports of the inside cylinders being crossed. The cylinders are inclined at 1 in 7, the valves being placed above the outside pair. Complete working drawings appeared in *Engineering*, March 5th, 1920.

Tank Engines.—The dimensions of these are given in Table XIX. Nos. 1 to 10 were built for passenger service, and Nos. 11 to 16 for mixed, goods, and shunting work. The G.E.R. engine, No. 3—Fig. 463—for London suburban passenger trains has much smaller coupled wheels than the L. and S.W.R. 4-6-2 engine, No. 13, Fig. 464, which is intended for the transfer of goods and coal traffic between Feltham sidings and the L.M. and S. systems at Brent and Willesden. Nos. 14 and 15 are heavy shunting engines.

The 2-6-4 wheel arrangement, new to British practice, appears in the S.E. and C.R. outside-

The addition of superheaters to tank engines, such as Nos. 3, 4 and 5, primarily intended for suburban traffic with numerous stops, has now become standard practice. The G.E.R. engine, No. 3, was one of two, the other engine working with saturated steam. Ten subsequent similar engines of 1921, one of which is shown by Fig. 463, were without superheaters, and had a total heating surface of 1394 square feet, but since the grouping with the L. and N.E.R. the latest engines of the type have again been provided with superheaters. The tube heating surface of these is 858 square feet, fire-box 110.2 square feet, and superheating surface 134.2. Apparently this class is to be one of the standard L. and N.E.R. types, for large numbers of them have recently been built at Gorton Works and by R. Stephenson and Co., Ltd.

Other tank engines mentioned in Table XIX

which are illustrated include (15) the 4-8-0 tank engine shown by Fig. 472, and designed by Mr. E. A. Watson in 1915 for the Great Southern and Western Railway of Ireland for shunting, and also transferring goods trains on the 1 in 80 gradients between Kingsbridge and Inchicore, and banking up to Clondalkin.

Fig. 473 illustrates one of the six 4-6-4 tank engines, built in 1922 by the North British

Ltd., and No. 8 by Kitson and Co., Ltd. The London, Midland and Scottish Railway 0-8-4 banking engine, No. 16, and the Caledonian 4-6-2 tank engine, No. 7, are shown by Figs. 470 and 471 respectively.

DETAILS.

Boilers.—There has been a tendency during the last few years to slope the fire-box roof down-



FIG. 459—G. T. GLOVER'S SIX-COUPLED ENGINE, GREAT NORTHERN RLY. (IRELAND), 1920-21

Locomotive Company to the designs of Mr. R. H. Whitelegg for the Glasgow and South-Western Railway, and the first of this type in Scotland.²

For shunting engines superheating is rarely used, and the L. and S.W.R. 4-8-0 engines (No. 14) are exceptional—Fig. 468.

The four-cylinder superheated engine for the N.S.R. was the only one of the type, and was the first tank engine to have four cylinders. The outside cranks are placed at 90 deg. with each other, and the inside cranks are also at 90 deg., but the outside and inside cranks on the same side, instead of being opposite each other, are at 135

degrees towards the back, and also to slope the back plate outwards from top to foundation ring. This has been done on several railways, both for large Belpaire and round-topped fire-boxes, and has been copied from American practice.

Ramsbottom safety valves, though still used, are rapidly giving place to pop valves of the Ross pattern. The "pop" valve, which has been used for a long time in America, is derived from the old T. Adams's valve, which had an extended circular outer lip, and was patented in this country in 1873 and 1875, the latter patent covering an annular pop chamber. The R. L. Ross valve was

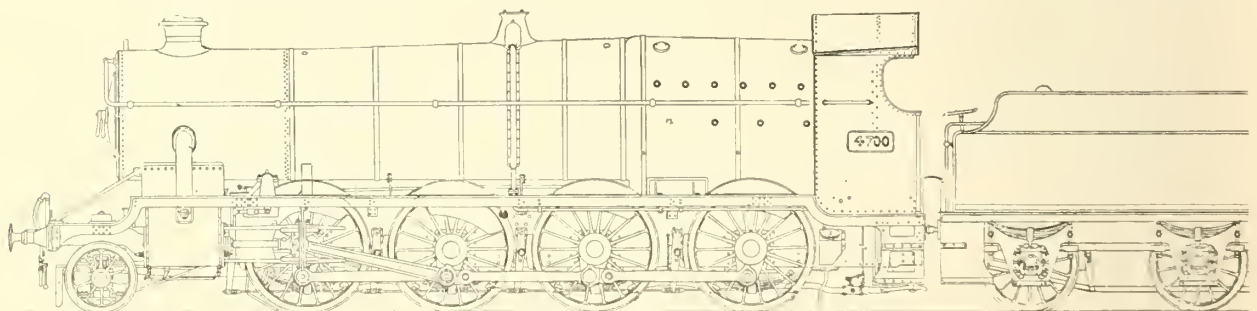

FIG. 460—G. J. CHURCHWARD'S 2-8-0 MIXED TRAFFIC ENGINE, GREAT WESTERN RLY., 1919

deg. Each cylinder has its own Walschaerts valve gear. The side tanks have since been removed and the locomotive is now at work as a goods tender engine, as illustrated by Fig. 469.

Of the tank engines in the table, Nos. 1, 4, 7 and 9 were built by the North British Locomotive Company, Ltd., No. 2 by Kerr, Stuart and Co.,

² Drawings and full particulars of these engines were given in the *LOCOMOTIVE* for July 15th, August 15th and December 15th, 1922.

patented in 1902 and 1904, but its extended use for locomotives really belongs to the present period.

Experiments were made on the G.C.R. during 1918-19 in burning pulverised fuel. Mr. J. G. Robinson's apparatus for this purpose was fully described and illustrated in *The Engineer*, April 25th, 1919.

Bogies and Pony Trucks.—Mr. R. E. L. Maunsell's S.E. and C.R. 2-6-0 engines of 1917

were provided with pony trucks, in which the pivot is hemispherical and rests in a hemispherical socket. The lateral displacement is controlled by inclined planes which work in an oil bath. The combination of spherical pivot and central inclined planes is similar in principle to that used for a number of years for bogies on the P.L.M. Railway, France, but the latter do not work in an oil bath. The trailing four-wheeled bogie of the S.E. and C.R. 2-6-4 tank engines is similar.³

Booster.—In 1923 Mr. Gresley fitted one of the Ivatt "Atlantic" engines on the L. & N.E.R. with one of the Franklin Supply Company's "boosters," consisting of a small auxiliary engine arranged underneath the foot-plate to drive the trailing axle through the intermediary of spur gearing. The "booster" is used for starting and when ascending heavy gradients at slow speeds. When the speed exceeds a predetermined amount the booster is automatically cut out.⁴

Motion, Valves and Valve Gear.—In order to reduce the weight of the engine and especially of the reciprocating masses, Mr. Gresley has adopted nickel-chrome steel. The piston-rods are hollow.⁵

Piston valves with long laps and travel, introduced previously by Mr. Churchward on the G.W.R., have also been adopted on other railways. The L.M.S. 4-6-0 tender and 4-6-4 tank engines, by Mr. G. Hughes, have 6 $\frac{3}{8}$ in. maximum travel and 1 $\frac{3}{16}$ in. steam lap. Although the reintroduction of long laps and travel appears to have been due to the influence of later American practice, it may be added that slide valves and gear of the L. and S.W.R. engines, by Joseph Beattie and his successor, W. G. Beattie, during the 1868-76 period were similarly arranged.

In 1915 the L. and N.W.R. converted a two-cylinder 4-6-0 engine to one with four cylinders. Each pair of cylinders on the same side of the engine have two piston valves on the same stem on Mr. C. F. Dendy Marshall's system. The piston valve heads are arranged to avoid the necessity for crossed ports. There are two pistons on the spindle, each with two heads, of which the front head of the front piston serves the front port of the outside cylinder, and the back head of the same piston serves the back port of the outside and the front port of the inside cylinder. The front head of the back piston serves the back port of the inside cylinder, which is placed slightly further back than the outside cylinder. To balance the valve the back piston has a dummy head at the back.⁶

The 0-8-4 tank engines, No. 16 in Table XIX, Fig. 470, have Joy's valve gear, standard with

³ For drawings see THE ENGINEER, October 5th, 1917.

⁴ See THE ENGINEER, February 8th, 1924, also the LOCOMOTIVE, August 15th, 1923, for drawings and details.

⁵ Particulars of the steel used and detailed drawings of the motion parts of the L. and N.E.R. "Pacific" engines were published in THE ENGINEER of January 26th and April 27th, 1923, and in the LOCOMOTIVE for May 15th, 1922.

⁶ Mr. Dendy Marshall's system was illustrated in THE ENGINEER, September 24th, 1915, and in the LOCOMOTIVE, October 15th, 1915.

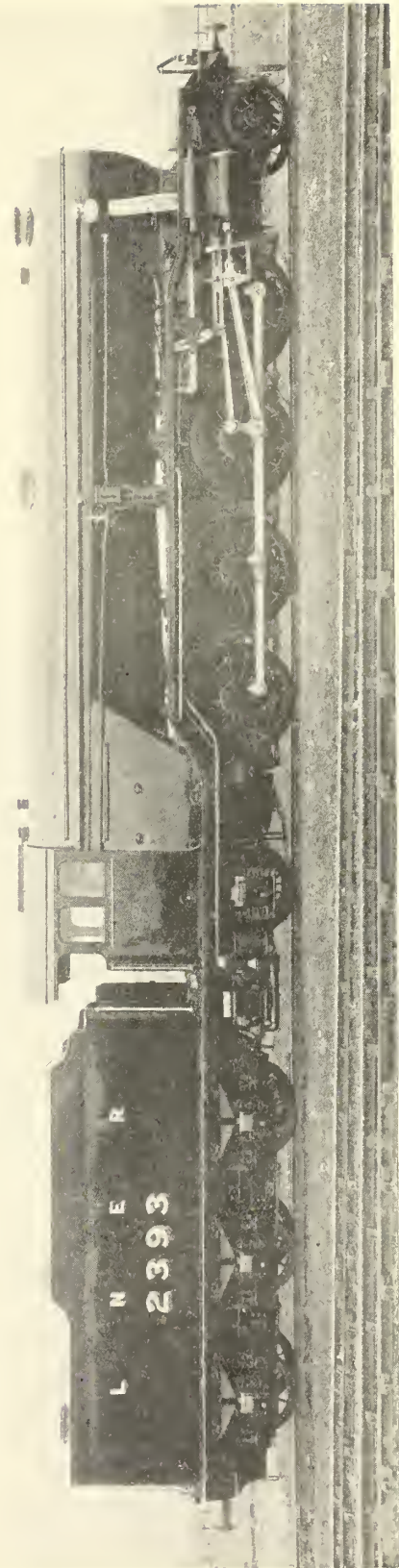

FIG. 461—H. N. GRESLEY'S 2-8-2 THREE-CYLINDER MINERAL ENGINE FITTED WITH BOOSTER, L. & N.E. RLY., 1925

the L. and N.W.R. 0-8-0 mineral engines previously built at Crewe. They are probably the last engines which will be provided with this gear, owing to the weakness caused by the hole in the connecting-rod in the case of modern engines working heavily with high boiler pressures. Some of the L.M.S.—L. and N.W. section—4-6-0 express engines with inside cylinders have been altered by the removal of Joy's gear and the substitution of a modification of Walschaerts gear designed by Mr. H. P. M. Beames in 1923. The gear is outside, the oscillation of the expansion link being produced by the usual return crank and excentric rod, but the movement of the combination lever is obtained from a connecting-rod attached to an extension of the coupling-rod in front of the driving crank pin. The combined movement is imparted to an outside dummy spindle, which is connected to the real inside valve spindle by a rocking lever. The 4-6-0 engine, by W. Beardmore and Co., for the L.M.S.R., shown at Wembley Exhibition in 1924, has this gear.⁷

Mr. Gresley's lever gear for three-cylinder engines, and also that of Mr. Holcroft have already been mentioned. A special feature of the former is that the fulcrum of the long lever is now provided with roller bearings.⁸

A new combined hand and steam reversing gear by Armstrong, Whitworth and Co., Ltd., 1923, was fitted by them to locomotives for India.⁹

Lubrication.—Mechanical or forced feed lubrication is now frequently supplied to the main bearings of large engines. On some railways, of which the locomotives, even when superheated, have the cylinders and valves lubricated by means of sight feed displacement lubricators, mechanical lubrication is used for the bearings.

LOCOMOTIVE TENDERS.

Very little has been said in the foregoing history on the subject of tenders, and therefore a few brief notes may be of interest.

Omitting the primitive tenders of the Stockton and Darlington and Liverpool and Manchester engines, several of which have been shown in the illustrations, the first type is that of R. Stephenson and Co. and Bury. Stephenson's four-wheeled tender of 1836-37, as shown in Tredgold's "Steam Engine," had wood frames with iron axle guards and axle-boxes outside the wheels. The springs, on which the wood frame rested directly, were situated immediately above the axle-boxes. This frame was developed from that of the tender of the "Rocket." In an improved form it was adopted on the Grand Junction Railway in the early Crewe engines, and remained standard on the L. and N.W.R., though with six

⁷ See drawings in *THE ENGINEER* of June 27th, 1924, and in the *LOCOMOTIVE* for June 15th, 1923.

⁸ For details of the gear see *THE ENGINEER* of July 26th, 1918, and January 26th, 1923.

⁹ Described in *THE ENGINEER* of August 17th, 1923, and in the *LOCOMOTIVE*, November 15th, 1923.

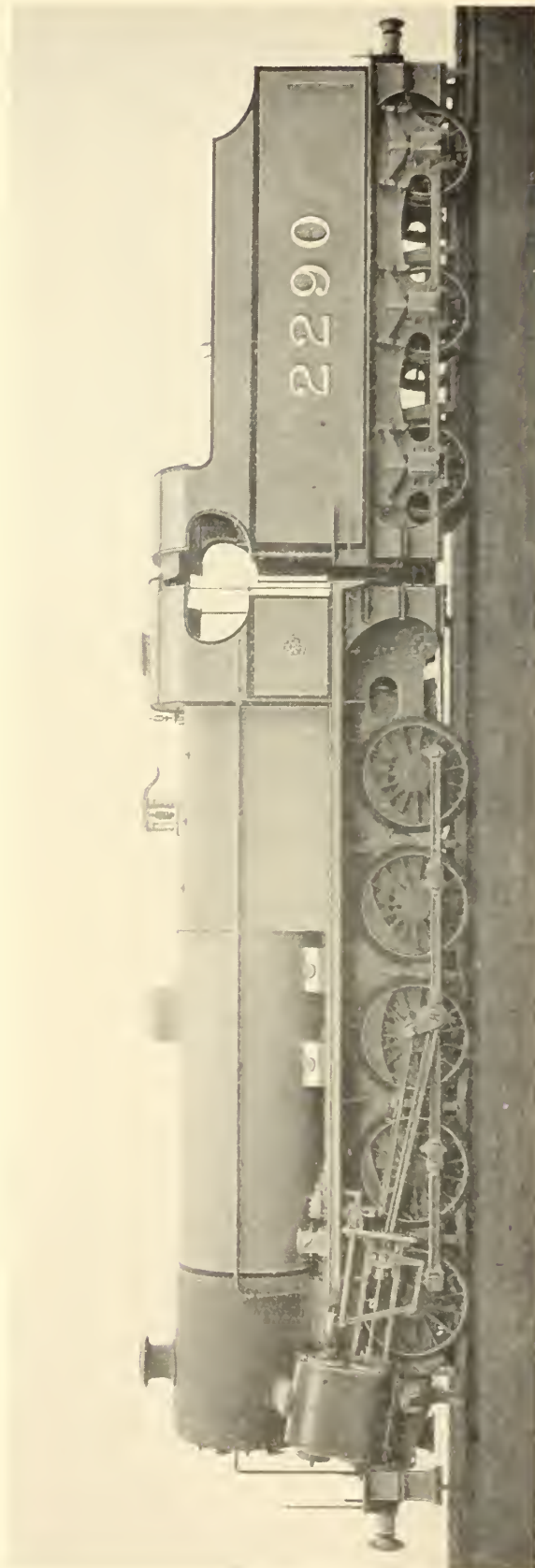

FIG. 462. SIR HENRY FOWLER'S TEN COUPLED BANKING ENGINE. MIDLAND R.V., 1919

wheels, until the end of F. W. Webb's superintendency in 1903 by which time it was long out of date. But it was very cheap to construct, and its long continuance on the L. and N.W.R. was partly due to the small water capacity—1800 gallons—which the use of water troughs permitted. The L. and N.W.R. standard tender weighed only 12 tons 1 cwt. empty. Similar tenders were used on many of E. Fletcher's N.E.R. engines until 1875.¹⁰

Bury's four-wheeled tenders of 1837 to 1845 were of a similar type, and were probably copied from Stephenson's design.

The date of the first six-wheeled tender is uncertain, but Sir D. Gooch's G.W.R. tenders of 1840-42 ran on six wheels. The framing was of the outside sandwich pattern, and double elliptical laminated springs were placed between the flitch

the object of making the axles interchangeable with the carrying axles of the engines. It was discarded by his successor in 1893.

We now come to what may be termed the first standard British tender, which had outside frames and axle-boxes and the springs placed outside *above* the platforms. The origin of the design is uncertain, but Sharp Brothers built this type in 1842, with sandwich frames and four wheels, and in 1846 with six wheels. It appears in Stephenson's York, Newcastle and Berwick express engine of 1848. The date of the first use of solid plate frames for this type of tender is unknown; but the earliest known to the writer were made by E. B. Wilson and Kitson about 1850. This type of tender was developed by Cudworth on the S.E.R., and his 1857 design—illustrated in Colburn, Plate 28—was used on nearly all railways, except

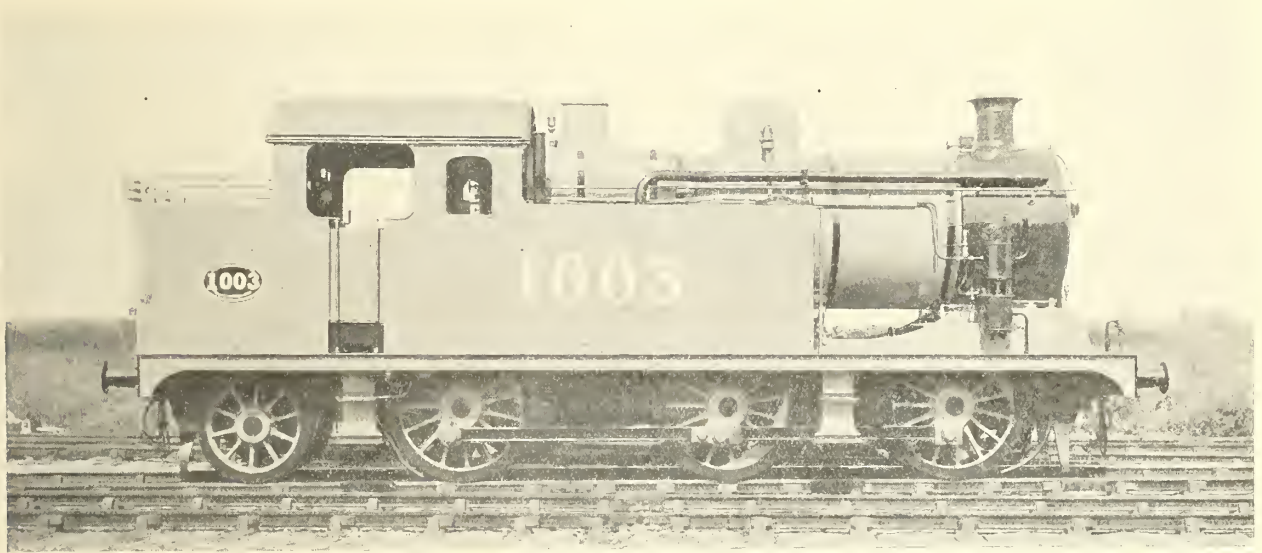

[Photo. Locomotive

FIG. 463—A. J. HILL'S 0-6-2 SUBURBAN TANK ENGINE, GREAT EASTERN RLY., 1914-21

plates of the frames immediately above the axle-boxes. This tender is shown in Fig. 44 *ante*. In 1846 Gooch discarded this pattern for one somewhat similar in design and appearance to the above wood-framed tenders, but with the important difference that the frames were of iron. About 1855 he returned to the sandwich-framed tender, as in Fig. 133 *ante*, with springs placed above the platforms.

The Vulcan Foundry tender of 1846 had inside frames and bearings, as in Fig. 56 *ante*. This design was rare in British practice until Stroudley adopted it on the Brighton Railway in 1880, with

¹⁰ Since the above was written Sir John A. F. Aspinall, in his Hawksley lecture (Inst. Mech. Engineers, November 6th, 1925) stated that John Ramsbottom's reason for making the L. and N.W.R. tender frames of timber was that the tender between engine and train should be the weakest part of the train and that it should break up first in case of collision and thus save the passenger carriages.

the L. and N.W.R., and was built with modifications until 1897 by J. Stirling. For the Northern Counties Committee, Ireland, and by Beyer, Peacock for the Dutch State Railways, similar tenders have been built during the early years of the present century. The sandwich-framed tender was gradually abandoned between 1863 and 1870, the last to construct it being E. Fletcher on the N.E.R.

Hawthorn's old tender of 1848 was not so convenient, since the springs were placed behind the sandwich framing, immediately above the axle-boxes. Nevertheless, this type, with plate frames, was adopted by P. Stirling on the G.N.R. from 1867 until 1882 and by S. W. Johnson on the G.E.R. and M.R. from 1867 to 1878. Subsequently, Johnson altered all these Midland tenders to the second standard type, to be

mentioned later, to render the springs more accessible.

Stroudley's tenders of 1871 to 1878 had the springs underhung beneath the outside axle-boxes.

immediately above the axle-boxes *below* the platforms. Not only are the springs visible and accessible, but the tanks can be widened to the edge of the platforms. J. E. McConnell on the L. and N.W.R. (Southern Division) was



FIG. 464—R. W. URIE'S 4-6-2 GOODS TANK ENGINE, SOUTHERN RLY. (FORMERLY L. & S.W. RLY.), 1921

(Photo. Locomotive



FIG. 465—R. E. L. MAUNSELL'S 2-6-4 PASSENGER TANK ENGINE, SOUTHERN RLY., 1917-25

Stroudley with great fidelity, adopted this design on the North British and Caledonian Railways. Stroudley abandoned it in 1880.

The second and present-day standard British tender with outside plate frames has the springs

apparently the first to introduce this type in 1851, and Joseph Beattie followed almost immediately afterwards on the L. and S.W.R., though the earlier tenders of the latter had double elliptical plate springs. Similar tenders with ordinary plate

springs were made by the Vulcan Foundry in 1853. For many years the only British railways which constructed such tenders were the L. and N.W.R. at Wolverton until 1863, and the L. and S.W.R., which has always used them since 1851.

wheeled tender rarely exceeded 1600 to 1800 gallons. From 1870 to 1875 2000 to 2200 gallons was the average capacity, though the first tenders of P. Stirling's G.N.R. 8ft. singles of 1870 carried 2700 gallons. S. W. Johnson's Midland

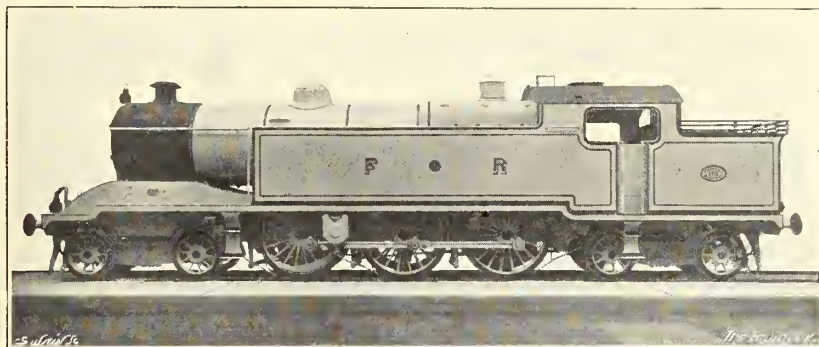

FIG. 466—KITSON & CO'S SIX-COUPLED PASSENGER TANK ENGINE, FURNESS RLY., 1920

In 1876 W. Adams introduced this design on the G.E.R., and it was perfected in its present form by S. W. Johnson on the Midland Railway in 1879. From that time onwards it rapidly spread to every railway in the country, except the L. and N.W.R., which had discarded McConnell's design in 1863, and continued with the old Crewe wood-framed tender until 1903.

For many years the tender tanks were of the horse-shoe pattern, surrounding the flat floor which formed the coal space. The fireman had to spend much time in shovelling coal forward to a convenient working position. During the 'seventies the floor was raised to gain additional space underneath for water. P. Stirling, S. W. Johnson, W. Stroudley, and W. Adams were amongst those

tenders of 1879 had a capacity of 2950 gallons, increased to 3250 gallons in 1885, and until the end of the century the usual capacity of six-wheeled main line tenders rarely exceeded 3500 gallons. At the present day there are a considerable number with a capacity of 4000 gallons of water and over 5 tons of coal.

Water pick-up apparatus, introduced by J. Ramsbottom in 1860, was used only on the L. and N.W.R. until about 1887, when the Lancashire and Yorkshire Railway put down water troughs. In the latter case one of the main considerations was the limited size of the then existing turntables, which necessitated a tender of short wheel base for 4-4-0 passenger engines. The first L. and Y.R. 4-4-0 engines of 1880 had to be built with

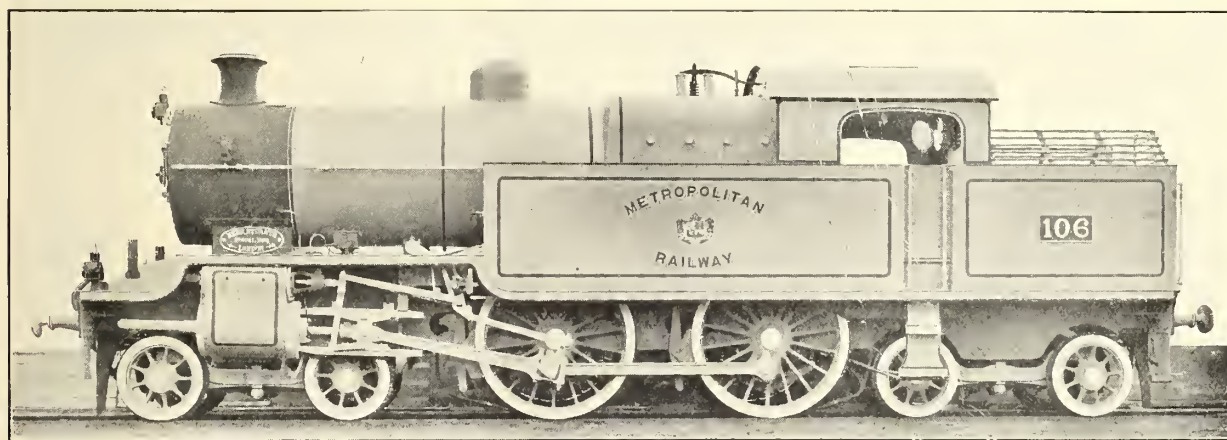

FIG. 467—C. JONES'S 4-4-4 PASSENGER TANK ENGINE, METROPOLITAN RLY., 1920

who did most towards the improvement in tender design at this period, when the inclined floor to cause the coal to work forward was introduced on several railways.

Until about 1868 the water capacity of a six-

four-wheeled tenders on this account, though subsequent engines from 1881 onwards had comparatively small six-wheeled tenders. But it was not until the early years of the present century that the Ramsbottom troughs and water pick-up

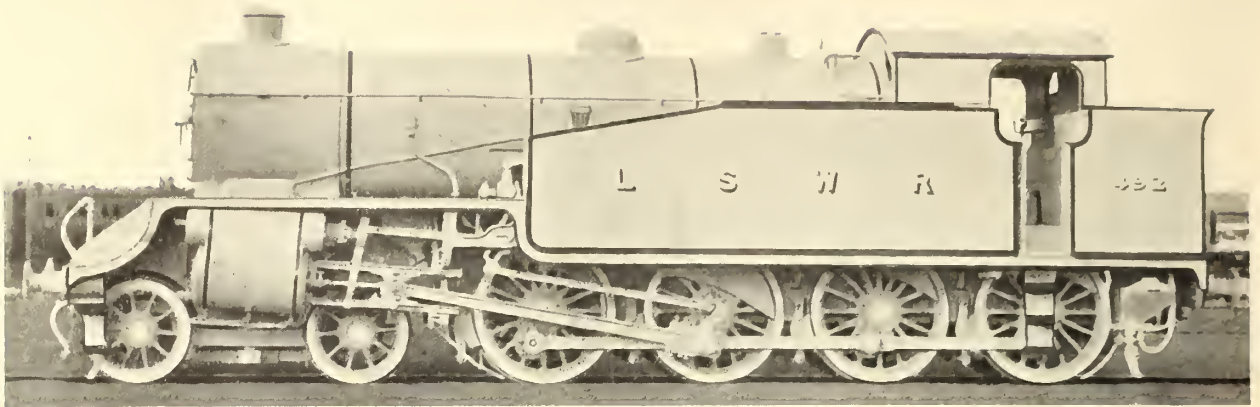

FIG. 468—R. W. URIE'S 4-8-0 SHUNTING TANK ENGINE, LONDON & SOUTH-WESTERN RLY., 1921

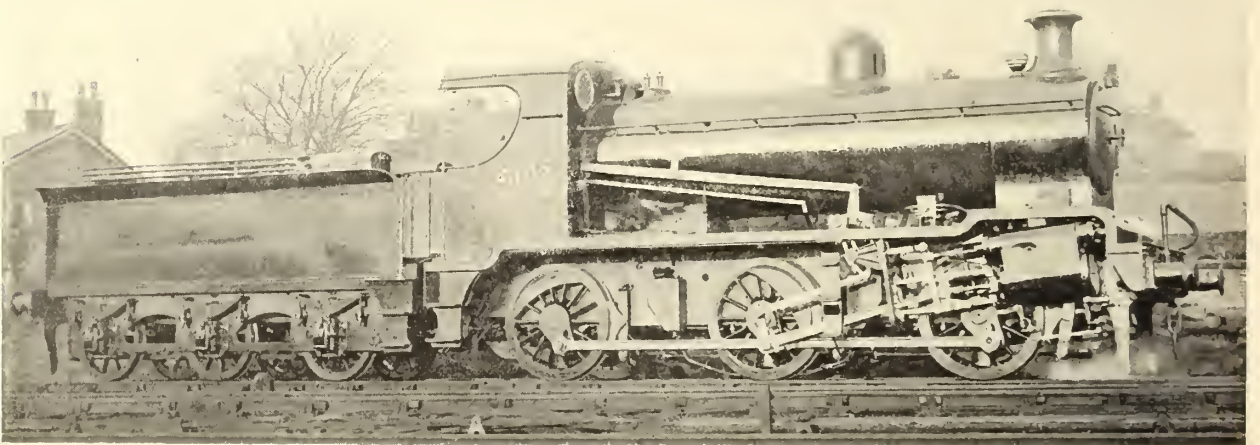

FIG. 469—J. A. HOOKHAM'S FOUR-CYLINDER GOODS ENGINE, NORTH STAFFORDSHIRE RLY. (NOW L.M. & S.R.), 1922

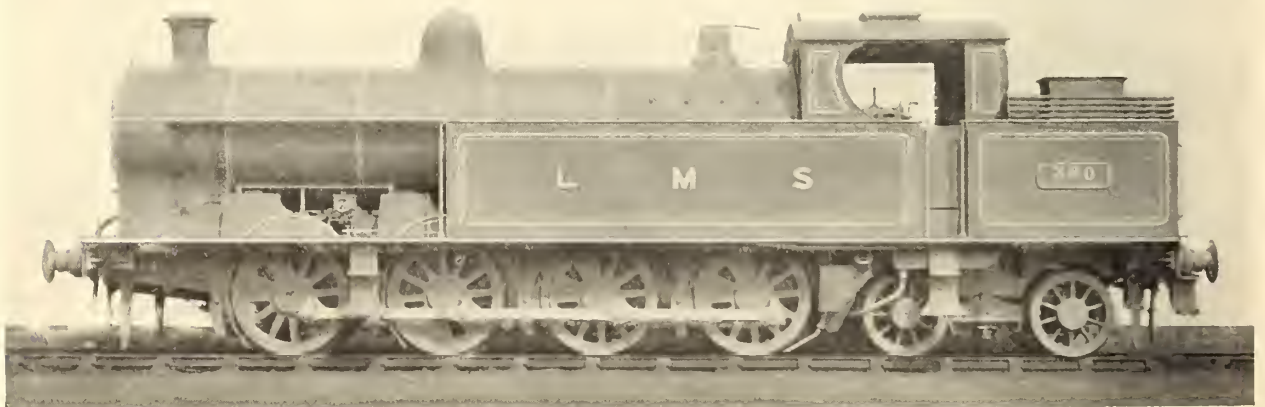

FIG. 470—H. P. M. BEAMES'S 0-8-4 BANKING ENGINE, LONDON, MIDLAND & SCOTTISH RLY., 1923

apparatus were generally adopted by other railways.

Eight-wheeled Tenders.—The first were J. Manson's tenders of 1890 on the Great North of Scotland Railway. They had an inside-framed leading bogie, but the two hind axles were rigid with outside bearings in the main frame. One of these tenders is shown in the illustration of the G.N. of S.K. engine, Fig. 342 *ante*. The first double-bogie tenders were built at St. Rollox for J. F. McIntosh's Caledonian engines of 1897. The bogie axle-boxes were outside, with single inverted springs, the load being carried on the boxes by compensating beams. Similar tenders were built by S. W. Johnson in 1900 for the ten large 4-2-2 engines, one of which was exhibited at Paris in that year. In 1902 Johnson altered the spring gear and adopted an independent laminated spring for each axle-box. These large tenders, which had a capacity of 4500 gallons, were nicknamed "water carts" on the Midland. When water troughs were put down subsequently the double-bogie tender was abandoned, and those in use were converted to the standard 3500-gallon six-wheeled type by cutting down the tanks.

D. Drummond on the L. and S.W.R. in 1901 designed his double-bogie tenders with inside bearings throughout, an awkward arrangement which renders the springs inaccessible. This remained the standard tender until Mr. Urie in 1917 adopted the double-bogie type with outside bearings and independent springs, similar to Mr. Johnson's 1902 type on the Midland. It may be added that on the L. and S.W.R. there is no level stretch of line conveniently situated where water troughs could be put down.

The double-bogie tender has a tendency to roll somewhat, and possibly for that reason eight-wheeled tenders with four rigid axles have latterly been built. The Lancashire and Yorkshire was the first to adopt this type, about 1902, for 0-8-0 mineral engines, and in 1922 Mr. Gresley provided similar tenders for the 4-6-2 express engines of the G.N.R. The latter tender carries 7000 gallons of water and 9 tons of coal.

Sir Vincent Raven's six-wheeled "self-trimming" tenders for the N.E.R. were fully described in *The Engineer* of September 17th, 1915. They have a capacity of 4125 gallons of water and $5\frac{1}{2}$ tons of coal.

CONCLUSION.

In concluding this historical account of the British locomotive the writer desires to acknowledge the generous help which he has received from the Chief Mechanical Engineers of the leading railways, and from the leading locomotive building firms, who have kindly provided photographs, drawings, and other valuable information. He is also indebted to Sir John Aspinall for several details of interest, to Sir Robert Hadfield, Bart., F.R.S., for information with regard to steel

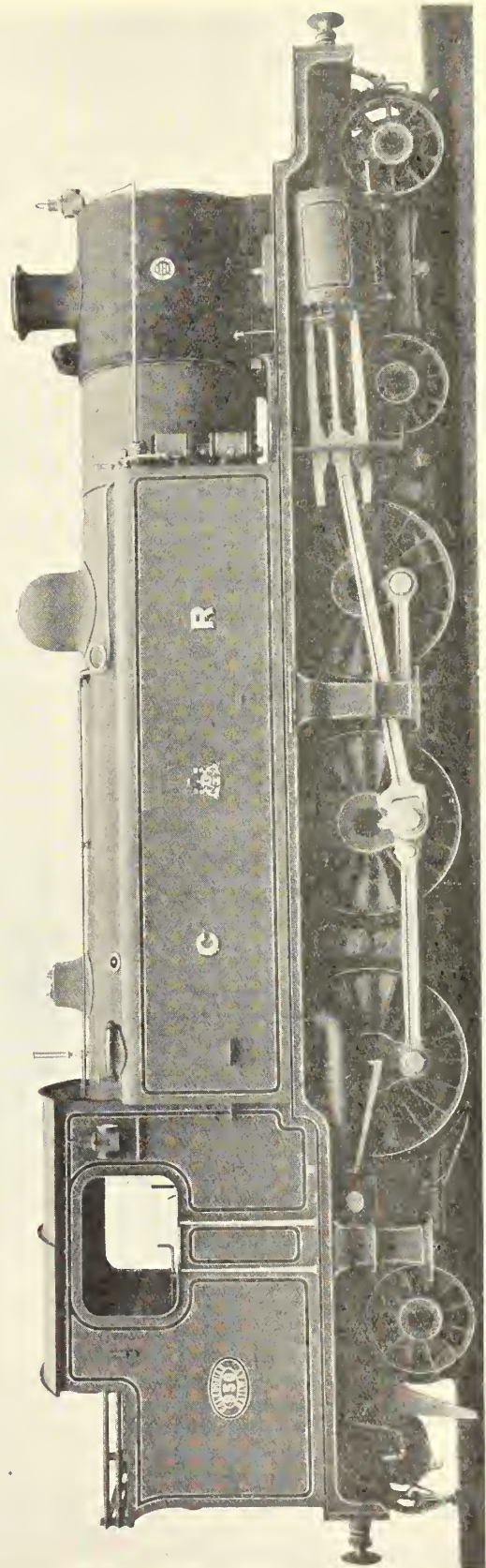

FIG. 471—W. PICKERSGILL'S SIX-COUPLED PASSENGER TANK ENGINE, CALEDONIAN RLY., 1917

castings, and to Hy. Bessemer and Co., Ltd., and Vickers, Ltd., for particulars of steel tires made in the early days. Special thanks are due to R. Stephenson and Co., Ltd., of Darlington, for permission to reproduce a few of the illustrations from their book "A Century of Locomotive

and to *Engineering*, from the old issues of which a number of details have been derived. For the use of a number of photographs acknowledgment is made to the Locomotive Publishing Company, Ltd., of London, and to Mr. G. F. Bird for line drawings of Great Northern and old

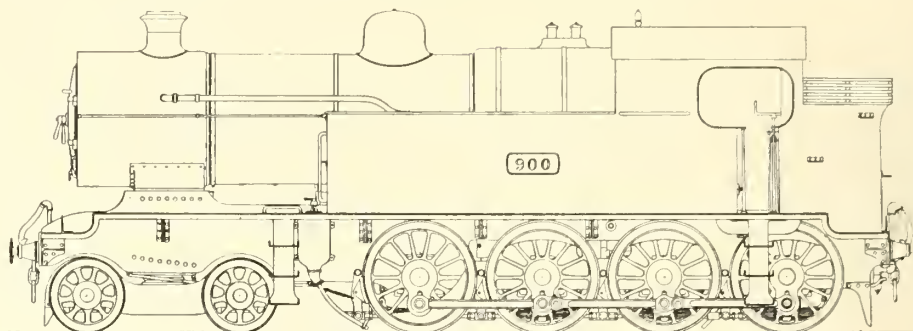

FIG. 472—E. A. WATSON'S 4-8-0 GOODS TANK ENGINE, G.T. SOUTHERN & WESTERN RLY. (IRELAND), 1915

Building," and also to Mr. J. S. Maclean for several illustrations from his "Locomotives of the North-Eastern Railway." He is also greatly indebted to Mr. J. G. H. Warren for information regarding the early period of Messrs. Stephen-

Great Western broad-gauge engines. Many line drawings have been added to the illustrations of Great Eastern locomotives, which have been taken from the series of historical articles which appeared in *The Locomotive Magazine* between 1902 and



FIG. 473—R. H. WHITELEGG'S "BAL TIC" TYPE TANK ENGINE, GLASGOW & SOUTH-WESTERN RLY., 1922

son's activities and for other help, and to Mr. E. A. Forward, of the Science Museum, South Kensington, for details of the "Sanspareil." Thanks are also due to the Institutions of Civil and Mechanical Engineers respectively for particulars derived from their published "Proceedings,"

1913. Several of the additional illustrations have also been kindly supplied by the Council of the Institution of Locomotive Engineers, and by *The Engineer* from among the numerous illustrations which have appeared in that journal.

Index

Names of particular locomotives are printed in italics. Drawings or illustrations are indicated by figures in heavy type. Abbreviations of titles of Railways have been used in many instances:—

<i>B. & N.C.R.</i> —Belfast & Northern Counties Railway	<i>G.S. & W.R.</i> —Great Southern & Western Railway	<i>L.M. & S.R.</i> —London, Midland & Scottish Railway
<i>B. & L.R.</i> —Bolton & Leigh Railway	<i>G.W.R.</i> —Great Western Railway	<i>L.T. & S.R.</i> —London, Tilbury & Southend Railway
<i>B. & E.R.</i> —Bristol & Exeter Railway	<i>H.R.</i> —Highland Railway	<i>M.S. & L.R.</i> —Manchester, Sheffield and Lincolnshire Railway
<i>C.R.</i> —Caledonian Railway	<i>L. & Y.R.</i> —Lancashire & Yorkshire Railway	<i>N.B.R.</i> —North British Railway
<i>C. & W.R.</i> —Canterbury & Whitstable Railway	<i>L. & M.R.</i> —Liverpool & Manchester Railway	<i>N.E.R.</i> —North Eastern Railway
<i>E.C.R.</i> —Eastern Counties Railway	<i>L. & N.E.R.</i> —London & North Eastern Railway	<i>N.L.R.</i> —North London Railway
<i>E.I.R.</i> —East Indian Railway	<i>L. & N.W.R.</i> —London & North Western Railway	<i>N.S.R.</i> —North Staffordshire Railway
<i>G. & S.W.R.</i> —Glasgow & South Western Railway	<i>L. & S.W.R.</i> —London & South Western Railway	<i>S.E.R.</i> —South Eastern Railway
<i>G.C.R.</i> —Great Central Railway	<i>L.B. & S.C.R.</i> —London, Brighton and South Coast Railway	<i>S.E. & C.R.</i> —South Eastern & Chatham Railway
<i>G.E.R.</i> —Great Eastern Railway	<i>L.C. & D.R.</i> —London, Chatham & Dover Railway	<i>S. & D.R.</i> —Stockton & Darlington Railway
<i>G.I.P.R.</i> —Great Indian Peninsula Railway		<i>T.V.R.</i> —Taff Vale Railway.
<i>G.N.R.</i> —Great Northern Railway		
<i>G.N. of S.R.</i> —Great North of Scotland Railway		

"A" loco., Great North of England Rly., 55.

Adams, T., safety valve, 364.

Adams, William, 119; tank loco. and bogie, N.L.R., **156**, 157, 162; N.L.R. 4-4-0 tank engine, 172, **173**; sand-box, 177; G.E.R. and L. & S.W.R. engines, 216, **217**; L. & S.W.R. 4-4-0 and 4-4-2 tank engines, 220; G.E.R. 2-6-0 goods engines, 222, **223**; L. & S.W.R. two-cylinder compound, 255; L. & S.W.R. 0-4-2 engines, 274, **275**; L. & S.W.R. 4-4-2 tank engines, **278**; boilers, 284; L. & S.W.R. 4-4-0 express engines, 296, **298**; G.E.R. tenders, 369.

Adams, W. Bridges, 84; spring tires and radial axles, 153, 154, 160; radial axles, **161**.

Adamson, D., & Co., 166.

Adelaide and Gawler Bridge Railway, locos. for, 140.

"*Adriatic*," L. & N.W.R. compound, 251.

"*Agenoria*" locomotive, Earl of Dudley's Railway (1829), 11.

Air inducing steam jets, 132.

Albion Coal Mining Co., locos. for, 139, 140.

"*Albion*" loco., South Yorks. Rly., **84**, 85.

Alford, R. F., paper, Society of Engineers, 319.

"*Alfred the Great*" class compounds, L. & N.W.R., 292, 324.

Allan, Alexander, 41, 50, **52**, 97, 118, 127, 206; super-vised building of Crampton loco., 71; fire-box, 131; slotted frames, 160; steel fire-boxes, 166, 206; link motion, 311.

Allen, Horatio, articulated loco., 313.

Ambergate, Nottingham, B. & E.J. Railway; E. B. Wilson & Co.'s loco., **86**.

America, engines for, 10, 11, 40.

"*America*" engine, Delaware and Hudson Canal Co., 10, 11.

American built engines for British railways, **42**, **307**.

American Railway, "*Pioneer*" loco. for an, 21, **22**.

Anglesey Central Railway, Fairlie loco., 315.

Anglo-Chilean Nitrate and Railway Co., Kitson-Meyer loco., **316**.

Antofagasta Railway, compound engines, 321.

Arbroath and Forfar Railway engines, 40, **42**.

Arica and Tacna Railway, Hawthorn's loco., **138**.

Armstrong, J., G.W.R. engines, 147, **167**, **186**, 222.

Armstrong, W. G., & Co., engines built by, 181, 357.

Armstrong, Whitworth & Co., hand and steam reversing gear, 366.

Articulated locomotives, 313.

Ashford works, 98.

Ashpan dampers, 64, 285.

Ashpan, water bottom, 227.

Aspinall, Sir J. A. F., wheels, 209; train resistances, 228; L. & Y.R. 4-4-0 engines, 273; 2-4-2 tank engines, 277, **278**; 0-6-0 goods engine, 280; 284; water pick-up apparatus, 287; 4-4-0 express engines, 296, **298**; 4-4-2 express engines, 303, **304**; 0-8-0 mineral engine, 308; experiments in steam jacketing, 311; smoke-box superheater, 311; balanced valves, 311; superheater, 352.

"*Atlantic*" type locos., 4-4-2, two cylinders, 330.

Atock, M., boiler, 284.

Australia, first locos. sent to, 140.

Austrian, Kaiser Ferdinand's Nordbahn, 112.

Austrian, double locos., 314.

Austrian Railways, 80, 218.

Avonside Engine Co., 145; tank loco. for G.N.R., **155**; tank locos. for Vale of Neath and Great Northern Rlys., **159**; 161; G.N.R. engines, 168; 180, 200; single Fairlie tank engine, **224**; Fairlie loco. for Festiniog Rly., **314**, 315; Fell locos. for the Rimutaka Incline, 319.

Axle, Caillet's movable, 161, **162**.

Axle, G.W.R. tank locomotive, trailing, **276**.

Axle-boxes, Fairbairn's, 126, **127**.

Axle-boxes and journals, 165, **225**, **226**.

Axle-boxes, Radial, **161**.

Axles and motion parts, 165.

Axles, hollow, 96.

Aydon, —, paper on oil fuel, 311.

- Balanced slide valves, 311.
 Balancing and balanced locos., 56, 60, 188.
 Baldry's rules, 161.
 Baldwin Loco. Works, 2-6-0 engines for G.N.R., M.R., and G.C. Rlys., 307.
 Banking engines, 59, 174, 363, 366.
 Barbier, M., train resistances, 228.
 Bar-framed bogie, G.W.R., 353.
 Bar framing, 10, 13, 21, 76.
 Barry Railway, 0-8-0 tender engines, 281, 282; 0-8-2 tank locos., 309.
 Battle of the Gauges, 65.
 Bauschinger, trials on German Railways, 126.
 Bayonne and Biarritz Rly., compound locos., 253.
 Beames, H.P.M., valve gear, 366; L.M. & S.R. 0-8-4 tank engines, 364, 370.
 Beattie, Joseph, 2-4-0 engine, L. & S.W.R., 98; feed-water apparatus, 99; goods engine, L. & S.W.R., 99; "*Canute*" class loco., L. & S.W.R. 114; feed-water heating apparatus, 114; 2-4-0 express engine, L. & S.W.R., 116, 117; fire-box and feed-water heater, 125; feed-water heating apparatus, 126; coupling-rods, 126, 127; tires, 127; tank loco., L. & S.W.R., 152; L. & S.W.R. engines, 171; running of L. & S.W.R. engines, 188; L. & S.W.R. tenders, 368-9.
 Beattie, W. G., L. & S.W.R. 4-4-0 engines, 215.
 "*Bee*" engine, trials of the, Midland Counties Rly., 131.
 Belfast and County Down Rly., 2-4-0 tank engine, 121; two-cylinder compound locos., 289; Beyer, Peacock & Co.'s compound tank engine, 306.
 Belfast and Northern Counties Rly., 178; 224; B. Malcolm's two-cylinder compound, 289, 290; Beyer, Peacock & Co.'s compound tank engine, 306.
 Belgian State Rlys., reversing gear, 175.
 Belgium, Stephenson engines for, 55.
 Belpaire, M., reversing gear, 175; fire-box, 237, 310.
 Bengal-Nagpur Rly., Worsdell compounds, 327; four-cylinder De Glehn compounds, 328.
 Bengal North Western Rly., class "*O*" 4-4-0 engines, 240, 241, 242.
 Bergisch-Märkische Rly., feed-water heater, 352.
 Bessmer, tires, 163.
 Beyer, Chas., 81, 100, 124; brake gear, 122.
 Beyer, Peacock & Co., 58, 117, 141, 191, 224; first locomotives, G.W.R. express engine, 113; Edinburgh & Glasgow Rly. engine, 114; tank engine for Belfast and County Down Rly., 121; goods engine for Egyptian Rlys., 123; goods engine, Midland Rly., 124, 125; engines for Madras Rly., 142; West Midland Rly. engine, 148; tank engine, West Midland Rly., 151; Metropolitan, also Bilbao and Tudela Rly. engines, 155, 156; Edinburgh and Glasgow Rly., 157; 2-4-0 engine for Midland Rly., 170; loco. for Dublin and Belfast Junction Rly., 178; locos. for Ireland, 177-8; 0-4-2 loco. for Ulster Rly., 179; 180; Tudela and Bilbao Rly. engines, 184; L. & S.W.R., 4-4-0 engines, 216, 217; Malines-Terneuzen Rly. loco., 237, 238; Sligo, Leitrim & N.C.R. tank loco., 237; Dutch State Rly. engines, 238; compound engines, 257; 4-2-2 engines for G.N.R. of Ireland, 265; L. & Y.R. engines, 273; L. & S.W.R. tank locos., 278; Mersey Rly. tank locos., 283; frames, 285; two-cylinder compounds for Ireland, 289, 290; three-cylinder compound engines for New South Wales, 293; Stratford and Midland Junction Rly., 2-4-0 engine, 296; Wirral Rly. tank engine, 305; Midland and South Western Junction Rly. 2-6-0 goods engines, 306; Belfast and County Down compound tank engine, 306; Lange and Livesey's patent twin locos. for Mexico, 313; Garratt locos. for San Paulo Rly., and L. & N.E.R., 318, 319; rack loco., Puerto Cabello and V. Rly., 320; rack engines for Nilgiri Rly., and Japanese Government, 321; G.C.R. three-cylinder tank engines, 338; rail motors, 350; Brotan boiler, 351; G.N.R. (Ireland) goods engines, 357, 364; tenders, 367.
 Bidder, G. P., 66.
 Billinton, L. B., L.B. & S.C.R. 4-6-4 tank engine, 341; L.B. & S.C.R., 2-6-0 engines, 343.
 Billinton, R. J., L.B. & S.C.R. 4-4-0 engines, 300; reversing gear, 311.
 "*Bird*" class engines, Liverpool and M. Rly., 50, 51.
 Birkenhead, Lancashire and Cheshire Jn. Rly., 136.
 Birmingham and Gloucester Rly. locos., 30; Norris engines, 42; hollow axles, 96; 118.
 Bissell trucks, 127, 138, 154, 161.
 Blackett, Christopher, Wylam Colliery locomotive, 6.
 "*Black Prince*" class, four-cylinder compounds, L. & N.W.R., 292, 293.
 Blast pipe experiments, Peacock's, 124.
 Blast pipe, origin of the, 6.
 Blast pipe, Vortex (W. Adams), 284.
 Blast pipe, Webb's, 207.
 Blast pipes, 111; 176; 310.
 "*Bloomer*" express engines, L. & N.W.R., 94; speed performances, 130; speed records, 230, 231, 236.
 Bochum system, tires, 163.
 Bodmer, J. G., balanced engine, 61, 62; 88; tires, 163.
 Bogie locomotives for abroad, 138.
 Bogie, locomotive patented by Wm. Chapman, 24.
 Bogie passenger engines, 149.
 Bogie, Wylam locomotives, 24.
 Bories and pony trucks, 364.
 Bories, engine, by J. B. Jervis, 25.
 Bories, general, 118; 162; 310; Adams, W., 156; N.L. & G.E. Rlys., 173; J. Stirling's, 196; W. Bouch's, 197, 198; leading, 212; J. Stirling's, 270, 271; T. W. Worsdell, 286.
 Boiler accessories, 207, 352.
 Boiler clothing, 36.
 Boiler fittings, 37.
 Boiler, first multitubular loco., 10, 31.
 Boilers, 165, 205, 227, 284, 310, 351; oval, 64; priming, 35; J. Beattie's, 133; W. Bouch's, 173; J. E. McConnell's, 132, 133; J. Stirling's, 196; underhung, 74.
 Bolton and Leigh Rly., "*Lancashire Witch*" loco., 1828, 9; purchase of the "*Sanspareil*" engine, 16.
 Bombay, Baroda & Central India Rly., metre gauge 4-4-0 engines, 239, 240, 242.
 Booster, 365.
 Borries, A von, 253; starting valve, 257.
 Borsig, A., 56; heat treatment of steel, 165.
 Bottomley, radial axle-box, 226.
 Bouch, William, locos. for Stockton and Darlington Rly., 48; goods engines, 58, 59; 0-6-0 goods engines, S. & D. Rly., 173; blast pipe, 176; 4-4-0 engine, N.E.R. (S. & D. section), 197; steam retarder, 209.
 Bow Works, 157, 172, 282.
 Box Tunnel, accident, G.W.R., 294.
 Braithwaite and Ericsson's engine "*Novelty*," L. & M. Rly., 1839, 14, 15; "*William the Fourth*" engine, 1830, L. & M. Rly., 17.

- Braithwaite and Milner locos., 33, 61.
 Brake gear, C. Beyer's, 122; counter pressure, 209; hydraulic, 220.
 Brake, Newark trials, speeds, 230, 235; on leading bogie wheels, 353.
 Brakes, engine, 105.
 Bramwell, Sir F., tires, 163.
 Brassey & Co., Canada Works, S.E.R. tank locos., 172; Fell centre rail locos., 319.
 Brecon and Merthyr Rly. 0-6-0 tank loco., 174.
 Brick arch, 131, 132; Midland Rly., 135.
 Brighton, Croydon and Dover Rlys. Joint Committee, 55, 66.
 Brighton Works, 98, 203.
 Bristol and Birmingham Rly., Vulcan Foundry loco., 54.
 Bristol and Exeter Rly., motor coach, 84; broad-gauge, double bogie tank engines, 106, 107, 108, 109; spring gear, 106, 108; rebuilding tanks by G.W.R., 109; Pearson's bogies, 119; tank locos., water tubes, 175; tank engines conversion, 210.
 British Mannesmann Tube Co., Brotan boiler loco., 351.
 Brittain, George, Caledonian Rly., 4-4-0 engines, 216.
 Broad-gauge tank locos., 105.
 Bromley, Massey, G.E.R., 4-2-2 express engines, 211; death of, 215; G.E.R. 2-6-0 goods engines, 222, 223; G.E.R. goods engines, 279, 280.
 Bromsgrove Works, 59.
 Brotan boiler, 351.
 Brown, F., Canadian Pacific Rly., 207.
 Brown, George & Co., tires, 163.
 Brown, W., blast pipe, 284.
 Brunel, I. K., 45.
 Bryce-Douglas, valve gear, 271; 287.
 Buddicom, J., 50.
 Buenos Aires Gt. Southern Rly., tank engines, 162.
 Buenos Aires Western Rly., Beyer, Peacock & Co.'s tanks, 305.
 Burma Rly., Fairlie locos. for, 316; Mallet locos., 317.
 Burnett, R. H., Metropolitan Rly. 0-6-0 tank locos., 174.
 Bury's E. bar-framed locos., 33; passenger engine, 34; evidence before Gauge Commissioners, 34; engine speeds, 67; engine "Liverpool," 1830, 18.
 Bury, Curtis and Kennedy, *Liverpool* loco., 71, 72; locos. built by, 48, 76, 105; grates, 111; engines, G.S. & W. Rly., 111; engines, Furness Rly., 157; tender, 367.
 Cabs, Locomotive, 177, 287; Highland Rly., 199.
 Caillet, M., check spring arrangement, 159, 161, 162.
 Caledonian Rly., 52; goods engines, 59, 82; 88, 89, 111; Connor's 2-4-0 engine, 117, 118; "8ft." single engines, 143; axles, 165; Connor's 2-4-0 engine, 171; 0-4-4 tank engine, 201; 0-6-0 long boiler goods engine, 204, 205; 206; G. Brittain's 4-4-0 engines, 216; Drummond's 0-4-4 tanks, 218; 2-4-2 tank engine, 220; 225; 228; Newark brake trials, 235; 4-2-2 engine, 265; speeds, 265-6; D. Drummond's 4-4-0 engines, 270; J. F. McIntosh's 4-4-0 engines, 298, 299; 4-6-0 engines, 332, 335; J. F. McIntosh's 4-6-0 goods engine, 342; J. F. McIntosh's 0-8-0 goods engines, 346, 347; J. F. McIntosh's 4-6-0 engines, 346; spark arrestor, 353; 4-6-0 three-cylinder engines, 355; valve gear, 362; W. Pickersgill's 4-6-2 tank engine, 364, 371; tenders, 368; J. F. McIntosh's tenders, 371.
 "Cambridge" engine and coach, Eastern Counties Rly., 84.
 Camden and Woodbury Railroad, loco. by Tayleur, 25, 26.
 Canada Works (Birkenhead), 99, 149; S.E.R. tank locos., 172; 181; Fell locos., 319.
 Canadian Pacific Rly., 207.
 Cantagallo Rly., Fell locos., 319.
 Canterbury and Whitstable Rly., "Invicta" loco. (1830), 17.
 "Canute" class loco., L. & S.W.R., 114.
 Cape Govt. Rlys., twin engines, 137; Kitson's twin tank locos., 313.
 Cardiff Rly., Kitson's tank loco., 284.
 Carlton and Stroudley's tire fastening, 286.
 Carmichael's, J. & C., loco., Dundee and Newtyle Rly., 27.
 Cartwright, Edwd., metallic packing, 287.
 "Castle" class, 4-6-0 engine, G.W.R., 356, 361.
 "Catch-me-who-can" locomotive, 5.
 Centenary, Stephenson (1881), 211, 220, 221; Darlington celebrations (1925), 3, 45.
 Central buffers, 191.
 Central S. African Rlys., rack engines, 321.
 Centre of gravity of locos., 64, 78.
 Chanter's fire-box, 131.
 Chapsal, M., feed-water heater, 352.
 "Charles Dickens" loco., L. & N.W.R., 195.
 Chester and Birkenhead Rly., Stephenson's engine, 98.
 Chilean Govt. Rlys., Vulcan Foundry locos., 321.
 Chimney, double, 310.
 Chimneys, 124; D. Jones's Highland Rly., 199.
 China, Mallet locos. for, 317.
 "Chittaprat" locomotive, S. & D. Rly., 3.
 Church, Dr., tank engine, 43.
 Churchward, G. J., G.W.R. 4-4-2 engines, 330; G.W.R. 4-6-0 engines, 331; G.W.R. four-cylinder 4-4-2 engine, 332; G.W.R. 4-6-2 engine "The Great Bear," 335, 336; G.W.R. 2-6-2 tank engine, 340; G.W.R. 2-6-0 engines, 342, 344; G.W.R. 2-8-0 goods engines, 347, 348; G.W.R. 2-8-0 tank engines, 349; G.W.R. boilers, 351; paper on "Large Loco. Boilers," 353; G.W.R. jumper blast pipe, 353; G.W.R. composite framing, 353; G.W.R. 2-8-0 engines, 362, 364.
 "City" class, G.W.R. 4-4-0 engines, 328, 329.
 "City of Liverpool" compound loco., L. & N.W.R., 245.
 Clack boxes, 166.
 Clark's, D.K., "Locomotive Machinery" and other works, 30, 62, 63, 73, 83, 84, 88, 90, 91, 101, 114, 128, 129, 130, 131, 132, 143, 146, 160, 162, 165, 181, 188, 228; air induction steam jets, 134, 273.
 "Claud Hamilton," G.E.R. express engine, 329.
 Coal burning, 64, 131; Dewrance's experiments, 132; systems, 134.
 Coal burning engines, Midland Rly., 134.
 Coal consumption and evaporation, D. K. Clark's, results, 134.
 Coal consumption of compounds, 250, 257.
 Coal consumption of L. & N.W.R. engines, 146.
 Coal consumption, 233.
 Coal, Welsh, on locos., 136.
 Cockerill, John, 137; double loco. for the Semmering incline, 413.
 Coke consumption, 65, 128, 129, 130, 131.
 Colburn, Z., remarks on loco. bogies, 24; references to his books, 30, 42, 62, 65, 67, 73, 84, 96, 106, 143, 149, 166, 175, 180, 182, 183, 316, 319, 367.

- Collett, C. B., G.W.R. "Castle" class 4-6-0 engine, 356, **361**.
- Colonies, Locos. for the, **139**.
- Combined engines and coaches, 84.
- Combustion chambers, 114, 132, 290.
- Comparison between the "Rocket" and "Sanspareil" engines, 15.
- Compensating gear (Sir D. Gooch's), 93; levers, 113, **127**, 209.
- Compound goods engines with two cylinders, 256; Compound locos., 88; F. W. Webb's first, **243**; L. & N.W.R., **243**, **244**; curves of crank effort, **249**; tank engines, 252; genesis of the three-cylinder, 243; Webb's three-cylinder system, 289; locos. with three cylinders, 322; with four cylinders, 324; in India, 327.
- Compound two-cylinder system, 257; performances of two-cylinder engines, 259.
- Condensing tank engines, first, 153.
- Condensing gear, G.W.R. tank locos., 153.
- Condensing apparatus, Metropolitan Rly., 155.
- Connecting rods, 39, 112, 203.
- Connor, Benjamin, Caledonian Rly. 2-4-0 engine, 117, **118**; Caledonian singles, **143**; 2-4-0 engine, Caledonian Rly., **171**; 0-6-0 goods engine, 204, **205**; uses steel fire-boxes, 206.
- Constructional details, 62.
- Continental locos., 237.
- Continuous expansion loco., E.C. Rly., 88, **89**; ditto L. & N.W.R., 246.
- Controlling arrangement for axles, 161, **162**.
- Cooke, C. J. Bowen, 132, 324; L. & N.W.R. "George the Fifth" class 4-4-0 engines, 330, **331**; L. & N.W.R. 4-4-0 engines, 328, **331**; L. & N.W.R. 4-6-0 "Prince of Wales" class, 331; L. & N.W.R. four-cylinder 4-6-0 engine, 332, **335**; L. & N.W.R. 0-8-0 engines, 346; L. & N.W.R. 0-8-2 tank engines, 349.
- Cooke Locomotive Works, Port Talbot Rly., 0-8-2 tank locos., 309.
- Copiapo and Caldera Rly., Kitson's engine, **138**.
- Copiapo Extension Rly., Hawthorn's engine, 139.
- Cordova and Espiel Rly., steam tender locos., 237.
- "Cornwall" engine, L. & N.W.R., 73, **74**; 70; speeds, 231.
- Cornwall Minerals Rly., loco. for back-to-back working, **313**.
- Coste and Perdonnet, remarks on Bolton and Leigh Rly. loco., 9.
- Couche's "Voie et Materiel Roulant," 314.
- Counter pressure brakes, 209.
- "County" class, G.W.R. 4-4-0 engines, 328, **329**.
- Coupled engines with inside cylinders, 39.
- Coupling rod ends, N.L.R., 157.
- Coupling rod joint, J. F. Stephenson's, **208**.
- Coupling rods, 175, 287; L. & Y.R., 122; Fairbairn's, **126**; J. Beattie's, 126, **127**.
- "Courier" class, G.W.R., fuel consumption, 129; "Courier" loco., L. & N.W.R., 71, **72**.
- Cowan's, William, bogies, 119, 162.
- Cowlairs Incline engine, **60**.
- Cowlairs Works, 60, 175, 195, 272.
- Crampton, T. R., 61, 70, **71**; regulator, 72; eccentrics, 72; engines, speeds of, 73; engine, Midland Rly., 72, **73**; merits and defects of, 73; "Lablache," 84; tank locos., **86**; G.N.R. loco., **86**; locos. for L.C. & D. Rly., **87**; 149, **150**; loco., S.E.R., speed record, 229.
- Crampton type engines, 68, 70.
- Crank axles, 112, 310.
- Crank effort, curves of, L. & N.W.R. compound engines, **249**.
- Cranks, Hall's, 240.
- Craven, J. C., 98; tank engine, L.B. & S.C.R., **120**, 121; Brighton Rly. 0-4-4 tank engine, 172.
- Crewe type of engine, 50, **52**; L. & N.W.R. goods, 52; passenger, L. & N.W.R., 41; speeds, 130.
- Crewe Works, 52, 163, 224.
- Crosshead, slotted, S. & D. Rly., 58.
- Cross, J., & Co., "White Raven" loco., St. Helen's Rly., **153**; 181; Fairlie engines for Neath and Brecon and Anglesey Central Rlys., 315.
- Cubitt, Benjamin, 62, 66, 106.
- Cudworth, J. I., 88, 151; spring gear, 98; coupled engine, S.E.R., **98**; 2-4-0 engine, S.E.R., **117**; fire-box, **133**, 134; "Mail" engines for S.E.R., **147**; fire-boxes, 166; S.E.R. 0-4-4 tank engines, **172**; sand-box, 177; singles, speeds of, 231; S.E.R. tenders, 367.
- Cumming, Charles, Highland Rly., 4-4-0 engine, **355**; Highland Rly. 4-6-0 engines, 355, **357**.
- Cumulative blast pipe, 207.
- Cylinders and valves for "Planet" type engines (1831), **21**.
- Cylinders, inside, Stephenson's arrangement, 109, 110; ratios and receiver capacity (Webb compounds), 247; D. Drummond's, 271; 311.
- Cylinders and valves, 354.
- Cylinder castings, 354.
- Dalby, Prof. W. E., 194.
- Darlington, Jubilee, 1875, 195.
- Darlington North Road Engine Works, 173.
- Day, John, 63.
- Dean, William, rebuilt goods engines, G.W.R., **167**; rebuilt "single" express engines, 187; single express engine, **210**; G.W.R. 4-2-4 tank engine, 219; tandem compound engines, **260**, **261**; G.W.R. 2-2-2 express engines, Nos. 9 and 10, **264**; G.W.R. 2-4-0 passenger engine, 266, **267**; G.W.R. 2-4-0 passenger engines, 268, **269**; G.W.R. 2-4-0 and 0-4-2 tank engines, **275**, **276**; G.W.R. 0-6-0 tank and tender engines, **280**, **281**; boilers, **284**; frames, 285; G.W.R. "3001" class b.g. express engines, **294**; G.W.R. bogie single express engine, **295**; G.W.R. 4-4-0 engines, 299, **300**; G.W.R. 4-6-0 goods engines, 307, **308**; G.W.R. bogie, 310; G.W.R. 4-4-0 engines, 328; G.W.R. 2-6-0 goods engines, 342, **343**.
- Decapod tank engine, G.E.R., **337**.
- Decauville Rly., Mallet loco., 317.
- Deeley, R. M., Midland Rly., 4-4-0 engine and valve gear, 329.
- Deflector plate, 136.
- Deflector, wind, 112.
- De Glehn four-cylinder compounds, Bengal-Nagpur Rly., 328; G.W.R., **325**.
- Delaware and Hudson Canal Co., Stephenson's loco. for the, 10, 11.
- Demarara Rly., Sharp Bros., loco. for, 140.
- Derby Works, 289, 305.
- Details of construction, 62, 109, 205, 225, 284, 310, 351.
- Dewrance, John, Liverpool and M. Rly. engines, 50, **51**; 63; double fire-box, **132**.
- "Director" class, G.C.R. 4-4-0 engines, 329, **330**.
- Displacement lubricators, 166.
- District Rly., 156.
- Dixon, John, 14, 24.
- Dodds, Isaac, method of fastening boiler, 38; 63; tires, 162; wedge motion, 54, 63, 106.
- Dodds, Ralph, used coupling-rods at Killingworth, 3.

- Dodds, T. W., 63; wedge motion, 63.
 Domeless engines, G. & S.W.R., 157.
 Dome, Hawthorn's steam, 111.
 Domes, steam, 35.
 Doncaster Works, 168, 171, 204.
 Double boiler tank engine, Wilson's, 104, 105.
 Double chimney, L. & N.W.R., 292.
 Double domes, L. & N.W.R., 97.
 Doublebois accident, G.W.R., 276.
 Douglas, G. K., 136.
 "Dreadnought" class compound locos., L. & N.W.R., 245.
 Druitt-Halpin's boiler, L. & Y.R., 352.
 Drummond, Dugald, bogie, 212; 4-4-0 express engine, N.B.R., 213, 214; N.B.R. 4-4-0 tanks and Caledonian Rly. 0-4-4 tanks, 218; Caledonian Rly. 4-2-2 engine, 265; 4-4-0 Caledonian Rly. engine, 270; cylinder design, 271; 0-4-2 tank engines, N.B.R., 275; boilers, 284; L. & S.W.R. 4-4-0 engines, 299; L. & S.W.R. four-cylinder engine, 301, 303; water tube fire-box, 310; L. & S.W.R. 4-4-0 engines, 328; L. & S.W.R. 4-4-0 engines, 330; L. & S.W.R. four-cylinder 4-6-0 engines, 332; L. & S.W.R. rail motors, 350; L. & S.W.R. steam dryer and feed-water heater, 352; spark arrester, 353; L. & S.W.R. 4-4-0 engines, 355; tenders, 368; L. & S.W.R. bogie tenders, 371.
 Drummond, Peter, G. & S.W.R. 4-4-0 engines, 329; 2-6-0 goods engines, 342, 343.
 Dublin and Belfast Junction Rly., loco. for, 178.
 Dublin and Drogheda Rly., Neilson's tank loco., 90, 91; engine brakes, 105; loco. for, 177.
 Dublin and Kingstown Rly. loco. "Hibernia," 28, 29; loco. "Vauxhall," 29; locos. "Victoria" and "Comet," 43; 63; 83; c.i. wheels, 209.
 Dublin and Wicklow Rly., Vulcan Foundry locos., 90.
 Dublin, Wicklow and Wexford Rly., tank locos., 92; locos., 179.
 Dübs, Henry, improved wedge gear, 63; wedge motion, 106; Caledonian Rly. engines, 171.
 Dübs & Co., 172, 218; Caledonian Rly. goods engines, 204, 205; G.E. and M.R. engines, 211; M.R. engines, 0-6-0, 221; Impl. Japanese Rlys., 238; metre gauge tank loco. for India, 239; I.S.R. engines, 239; B.B. & C.I. Rly., Rajputana-Malwa Rly. 4-4-0 engine, 239, 240, 242; 0-4-4 metre gauge engine for India, 239; C. Rly. engines, 271; L. & S.W.R. tank engines, 278; 300; L.T. & S.R. tanks, 305.
 Dudgeon's tube expander, 175.
 "Dunalastair" and "Dunalastair 2nd" classes engines, Caledonian Rly., 298, 299.
 Dundalk and Enniskillen Rly., 0-4-2 loco. for, 178, 179.
 Dundee and Newtyle Rly., Carmichael's loco., 27.
 Dundee and Perth Rly. loco., 71.
 Dunham cranks, 104.
 Dutch State Rlys., locos. for, 178; 2-4-0 engines, 237, 238; frames, 285; tenders, 367.
 D.X. goods engines, L. & N.W.R., 122, 123; link motion for, 127.
 Earl of Dudley's Rly. engine "Agenoria," 11.
 East Coast Scotch trains, engine working, 189, 191.
 Eastern Bengal Rly. 0-4-2 engines, 239.
 Eastern Counties Rly. locos., 33; 56; 61, 62; 67; Crampton's, 72; Samuel's inspection engine, also "Cambridge" engine and coach, 84; "Enfield" motor coach, 84; compound loco., 88, 89; Gooch's tank engines, 90; goods engines, 99; 111; Sinclair's 2-4-0 goods engines, 118; 131; 132; 134; Stephenson's long boiler engine, 229; speed records, 229; Crampton engines, 73.
 Eastern Rly. of France, fuel consumption, 128; crank axles, 310; Flaman boiler, 351.
 East Indian Rly. locos., 140, 141; tank locos. for, 141; locos. for the, 180.
 East Kent Rly. (L.C. & D. Rly.), tank engines, 120.
 Eaton, R., Grand Trunk Rly. locos., 183.
 Edinburgh & Glasgow Rly. locos., 34, 228; banking engines "Hercules" and "Samson," 59, 60; tank locos., 89, 90; single express engine, 113, 114; Byeer, Peacock 0-4-2 locos., 157.
 Edinburgh Northern Rly. locos., 86.
 Egypt, engine for the Viceroy of, 139.
 Egyptian State Rlys., Stephenson engines for, 55; Stephenson engines for, 99; Beyer, Peacock's goods engines for, 123, 124; locos. for, 139; Neilson's engines for, 143; goods loco. for, 157, 158; Trevithick's feed-water experiments, 352.
 Eight-coupled tank locos., 159, 309, 348.
 Eight-coupled tender engines, 281, 308, 346.
 Eight-wheeled tenders, 371.
 Ely, T. N., bogie, 219.
 "Enfield" motor coach, Eastern Counties Rly., 84.
 Engerth, 137.
 Engines, 0-4-2 type, 217, 273; 4-4-0, 195, 213, 215; 4-4-2 express, 301; 4-6-0 express, 304; 4-6-0 express goods, 346; 4-6-0 express, two-cylinder type, 331; 4-6-2 express, 335.
 England, Geo., & Co., tank engines, 91; wind deflectors, 112; locos. for Geelong Rly., 140; G.W.R. engines, 147.
 Escher, Wyss & Co., 181.
 Evaporative power of boilers, 66.
 Evaporation tests, Midland Rly., 136.
 Excentrics, Crampton's, 72.
 Exhaust passages, 39.
 Exhaust pipe, Stephenson's, 24.
 Exhibition, London (1851), 72, 165.
 Exhibition, London (1862), 143, 146, 165, 181, 316.
 Exhibition, Paris (1867), 145, 181, 287.
 Exhibition, Vienna (1873), 316.
 Exhibition, Paris (1878), 202, 243.
 Exhibition, Inventions (1885), 245.
 Exhibition, Liverpool (1886), 245.
 Exhibition, Edinburgh (1886), 265, 271.
 Exhibition, Manchester (1887), 253.
 Exhibition, Paris (1889), 266.
 Exhibition, Chicago (1893), 290.
 Exhibition, Paris (1900), 295, 329.
 Exhibition, Darlington Centenary (1925), 348.
 Expansion brackets, 110.
 "Experiment" class, compound engine, L. & N.W.R., 243, 244.
 "Experiment" loco., S. & D. Rly., 4.
 "Express," The, East Indian Rly., 141.
 Express passenger engines, 92, 355; 2-2-2 type, 210.
 "Faerie Queen" loco., E.I.R., 142.
 Fairbairn, W., & Sons, 49, 50, 78, 97, 141, 145; Bury type locos., 76; tank engine for the "Little" North Western Rly., 90, 91; L. & N.W.R. express locos., 95; goods engines, 102; coupling-rods, 126; axle-box, 126, 127; Furness Rly. locos., 157.
 Fairbairn, Sir Wm., test of axle steel, 165.
 Fairbairn type engines for Ireland, 179.
 "Fairfield" motor coach, 84.
 Fairlie double locos., 314.

- Fairlie Engine Co., single Fairlie tank engine, S.M. & A. Rly., **224**.
- Fairlie type tank loco., G.S. & W. Rly., 179, **180**.
- Farey, John, evidence before Committee of House of Commons, 6.
- Feed pumps, 63.
- Feed-water apparatus, Beattie's, 99; feed-water heaters, Beattie's, 114; feed-water arrangement, S. & D.R., 149; heater, Bouch's, 173; heating, 352.
- Fell, J. B., central rail locos. for steep gradients, 319, **320**.
- Fenton, James, 77.
- Fenton, Murray and Jackson, build engines to Stephenson's designs, 21; 50.
- Fenton, Murray and Wood, first safety valves (1815), 6.
- Fernihough, W., on balancing, 56; 62, 88, 119.
- Festiniog Rly., Fairlie loco., **314**, 315.
- Fire-bars, c.i., 126.
- Fire-box, M.S. & L. Rly., 101; roof stays, 36; water tubes, 175.
- Fire-boxes, 35, 205; J. Beattie's double, 117; M. Belpaire's, 237; W. Bouch's, 175; copper, 269; J. I. Cudworth's, **133**, 134, 166; J. Dewrance's double, **132**; iron, 197; J. E. McConnell's, 102; steel, 166, 206; J. F. Stephenson's, 207.
- Fire-boxes and tubes, Manchester and Bolton Rly., 36.
- Fire-door and brick arch, Midland Rly., **135**.
- "*Fire Fly*" loco., Camden and Woodbury Railroad, 25, **26**.
- Fittings, 166.
- Flachat and Petiet, on boilers, 35.
- Flaman boiler, 351.
- Flamme, M., superheating, 352.
- Fletcher, Edward, cylinder cocks, 24; N.E.Rly., coupled engines, 148; N.E.R., 4-4-0 engines for Whitby line, **150**; goods engines, 158; reversing gear, 175; rebuilt 2-4-0 engines, 198; N.E.R. 0-4-4 tank loco., **200**; N.E.R. goods engines, 203; "901" class 2-4-0 express loco., N.E.R., **191**; N.E.R. 0-6-0 goods engines, 221, **222**; tenders, 367.
- "Flying Dutchman," accident to the, 211.
- Folkestone Harbour branch, locos. for, 86.
- Forney engine, 201.
- Forrester's, G., engine, Dublin & Kingstown Rly., **29**.
- Forrester & Co., Dublin and Kingstown Rly., 43; 50, 83.
- Fossick & Hackworth, 48; Llanelly Rly. loco., 158, **159**.
- Foster and Rastrick's loco., "*Stourbridge Lion*" and "*Igenoria*" (1829), **10**.
- Four coupled express and passenger engines, 97, 168, 295, 296.
- Four coupled goods engines, 157.
- Four coupled passenger tank engines, 172, 219.
- Four-cylinder compound engines, Webb's system, 292.
- Four-cylinder locomotive, First, 3.
- Four-cylinder non-compound engines, 300.
- Four-cylinder tandem compound locos., **259**, 260.
- Fowler, John, & Co., 168.
- Fowler, Sir Henry, Midland Rly. compound, **323**; M.R. 0-6-0 goods engines, 341; Somerset and Dorset Rly. 2-8-0 engines, 348, **350**; M.R. 0-10-0 banking engine, 363, **366**.
- Fowler, Sir John, 162.
- Fox, Walker & Co., Windsor and Annapolis Rly. locos., 183.
- Frame plates, rolled, 175.
- Frames, axles, bogies, etc., 353.
- Frames, steel, 220.
- Frames of goods engines, 100.
- Frames, 38, 111, 160, 285; double, 97.
- France, Stephenson's locos. for, 10; Crampton's locos. in, 72, 73.
- Franklin Supply Co., booster, 365.
- Friction wheels, designs of, 32.
- Fuel, locomotive, 130, 131; consumption, N.E.R. and M.R. engines, 259; 65, 128.
- Furness Rly., Sharp's tank locos., 91; Bury, also Sharp, Stewart locos., 157; banking engines, 174; first engine to have Joy's gear, 226; Kitson & Co.'s 4-6-4 tank engine, 363, **369**.
- Gab motion, 39.
- Galloway's loco. "*Caledonian*," Liverpool and Manchester Rly., 27, 86.
- Garratt locos., **318**, **319**.
- Gateshead Works, 200, 269, 339.
- Gauge Commission, 43, 45, 50, 54, 55, 59, 61, 65, 66, 68, 106; E. Bury's evidence, 34.
- Gauges, 111.
- Geelong Rly., locos. for, 140.
- German Rlys., experience with compounds, 257.
- German Railway Engineers, Union of, 240.
- Germany, Crampton engines, 73.
- Ghat incline engines, G.I.P. Rly., **141**, **181**, **182**, 183.
- Giffard's injector, 166.
- Gilbert, David, evidence before House of Commons Committee, 6.
- Gilkes, Wilson & Co., 56.
- Giovi incline, Locos. for the, **137**, 313.
- "*Gladstone*" class express engine, L.B. & S.C.R., 273, **274**.
- Glasgow and Ayr Rly. locos., 79.
- Glasgow and Garnkirk Rly. goods engine, 21.
- Glasgow and South Western Rly., 163, 166; Crampton loco., **87**, 88; P. Stirling's single express engine, **114**, 115; 0-4-2 mineral engine, 118, **119**; P. Stirling's goods engines, **125**, **157**; 0-4-2 engines, 172; J. Stirling's 4-4-0 express engines, 195, **196**; H. Smellie's 2-4-0 engine, **212**; H. Smellie's 4-4-0 engines, **272**; J. Manson's bogie tenders, 272-3; J. Manson's 4-4-0 engines, 298; J. Manson's four-cylinder engine, **301**; P. Drummond's 4-4-0 engine, 329, 330; J. Manson's 4-6-0 engine, 331, **333**; P. Drummond's 2-6-0 goods engines, 342, **343**; R. H. Whitelegg's reconstructed four-cylinder 4-4-0 engine, 355, **356**; R. II. Whitelegg's 4-6-4 tank engines, 364, **372**.
- Glasgow, Paisley, Kilmarnock and Ayr Rly., 40.
- Glover, G. T., G.N.R. (Ireland) goods engines, 357, **364**.
- "*Goliath*" goods engine, L. & M.R. (1831), **20**, 21.
- Gooch, Daniel, 42, 66, 88; first designs at Swindon, 45; G.W.R. broad-gauge engines, **68**; G.W.R. bogie, **69**; compensating gear, 93; Gooch's smoke-box doors, 111; sand-box, **112**; standard gauge express engine, G.W.R., **113**; G.W.R. broad-gauge 2-4-0 passenger engines, **115**, 116; broad gauge 4-4-0 passenger engine, **115**; bogie tank engines, 119; coupled engines, G.W.R., narrow gauge, 147; G.W.R. locos. for Metropolitan Rly., **153**; tires, 162; experiments, 228; G.W.R. tenders, 367.
- Gooch, John Viret, L. & S.W. express engines, 52; double ported slide valves, 63; link motion, 63; L. & S.W.R. engines, 79; tank locos., Eastern Counties Rly., **90**; goods engine, Eastern Counties Rly., 99; 111; coke consumption, 131.

- Goodman, Professor, experiments, 166.
- Goods engines, 0-4-2 type, 24; goods engines, long boiler, 6-coupled, 58; with outside cylinders, 82; 0-6-0 type, 81, 100, 122, 202, 221, 279, 341; 2-6-0 type, 222, 306, 342; 4-6-0 type, 307.
- Gorton Works, 214, 222, 263, 363.
- Goss, Dr., experiments at Purdue University, 7, 194.
- "Gothic" fire-boxes, 35.
- Gouin & Co., Fell locos, 319.
- Grand Central Belge Rly., Meyer loco., 316.
- Grand Junction Rly. locos., 30, 34, 50; trial of Cranpton loco., 71.
- Grand Trunk Rly., Neilson's locos., 183.
- Grant Loco. Works, double blast pipe, 7; locos., 287.
- Grates, 111; tilting, 166; water, 207.
- Gray and Chanter's fire-boxes, 131.
- Gray, John, engines for the Hull and Selby Rly., 42, 49; "horse leg" motion, 43, 61; engine for the L. & Brighton Rly., 76.
- Grazi-Tsaritsin Rly., oil fuel burning, 311.
- "Great Bear," G.W.R. 4-6-2 engine, 335, 336.
- "Great Britain" class engine, G.W.R., trials of the, 128.
- "Great Britain" banking engine, Birmingham and Gloucester Rly., 59.
- Great Central Rly., H. Pollitt's 4-2-2 express engines, 295, 297; Smith compound engines, 323, 324; J. G. Robinson's 4-4-0 engines, 329, 330; 4-6-0 engines, 332, 333; J. G. Robinson's three-cylinder Atlantic engine, 336; J. G. Robinson's three-cylinder tank engines, 338; 4-6-2 tank engine, 341; J. G. Robinson's 4-6-0 goods engines, 346; J. G. Robinson's 0-8-0 goods engines, 347, 348; J. G. Robinson's 2-8-0 goods engines, 347, 349; J. G. Robinson's 4-6-0 engines, 355, 362; J. G. Robinson's 2-6-4 tank engine, 363.
- Great Eastern Rly., goods engines, 99; R. Sinclair's express engine, 144, 145; 2-4-2 tank engine, 154; tank engine, 161; tires, 163, 164; steel, 165; Johnson's 2-4-0 engines, 170, 171; bogies, 173; Johnson's 4-4-0 express engines, 197; Johnson's 0-4-4 tank engines, 200; Bromley's 4-2-2 express engines, 211; W. Adams's 4-4-0 engines, 216, 217; W. Adams's 2-6-0 goods engines, 222, 223; circular slide valves, 226; speed records, 229; T. W. Worsdell's two-cylinder compound express engine, 253, 254; 0-6-0 compound goods engine, 257, 258; J. Holden's 2-2-2 express engine, 264, 265; T. W. Worsdell's 2-4-0 express engine, 266; J. Holden's 2-4-0 express engines, 267, 268; T. W. Worsdell's 2-4-2 tank engines, 277; J. Holden's 2-4-2 tank engines, 277; Bromley's 0-6-0 goods engines, 279, 280; cast steel wheels, 286; J. Holden's bogie single express engine, 295; J. Holden's 2-4-0 engines, 296, 297; J. Holden's 2-4-2 tank engines, 305; J. Holden's liquid fuel apparatus, 311, 312; J. Holden's "1900" class 4-4-0 engines, 329, 330; 4-6-0 engines, 332, 333; J. Holden's three-cylinder 0-10-0 engine, 337; A. J. Hill's 0-6-0 goods engine, 357; A. J. Hill's 0-6-2 tank engine, 363, 367; tenders, 367; W. Adams's tenders, 369.
- Great Indian Peninsula Rly., locos. for, 140, 141; 4-6-0 and 0-8-0 tank locos., 181, 182, 183.
- Great Luxembourg Rly., Stephenson's engines, 137, 138.
- Great Northern Rly., goods locos., 82; Cranpton express locos., 86, 87; converted tank locos., 92; Hawthorn's express engine, 92; Sturrock's express engine, 97; Hawthorn's coupled engine, 98; 100, 110; genesis of singles, 115; Hawthorn's 2-4-0 express engine, 116; Sturrock's express engine, 146, 147; 0-4-2 tank engine, 155; 0-8-0 tank locos., 159; steam tender loco., 160; tank engine, 161, 163; axles, 165; clack boxes, 166; Sturrock's express engine, rebuilt express engine and Stirling's express engine, 168; 2-4-0 express engines, 168, 169; Stirling's 0-4-2 engines, 171, 172; 0-6-0 saddle tank, 174; cabs, 177; 8ft. single express engine, 185; train timings, 188; Stirling's goods engines, 203, 204; Ivatt 4-4-2 tank engines, 226; speed records, 229; Hawthorn loco., 230; train, Newark brake trials, 230, 235; speeds, 231; coal consumption, 234; P. Stirling's 2-2-2 express engines, 263, 264; P. Stirling's 8ft. single express engines, 294; Ivatt's 4-2-2 express engines, 295, 297; P. Stirling's 2-4-0 engines, 296; H. A. Ivatt's 4-4-2 express engine, 301, 303; 330, 331; H. A. Ivatt's 4-4-2 tank locos., 305; Baldwin Loco. Works 2-6-0 engines, 307; H. A. Ivatt's 0-8-0 mineral engines, 308, 309; four-cylinder compound 4-4-2 engines, 325, 326; H. A. Ivatt's four-cylinder 4-4-2 engine, 332; H. N. Gresley's 2-6-0 engines, 343, 344; H. A. Ivatt's 0-8-2 tank engines, 348; H. N. Gresley's 2-8-0 engines, 348, 349; rail motors, 350; bar-framed bogie, 353; pony truck, 354; Marshall's valve gear, 354; Ivatt's reversing gear, 354; H. N. Gresley's three-cylinder Pacific type locos., 356, 362; 2-6-0 and 2-8-0 engines, 362; tenders, 367; P. Stirling's tenders, 369; H. N. Gresley's eight-wheeled tenders, 371.
- Great Northern Rly. of Ireland, locos. for, 177-8; 4-2-2 engines by Beyer, Peacock & Co., 265; G. T. Glover's 0-6-0 goods engine, 357, 364.
- Great North of England Rly., Engines for the, 40, 50; engine "A," 55.
- Great North of Scotland Rly., 134, 150; bogies, 119; J. Manson's 4-4-0 express engines, 272, 273; J. Manson's tenders, 371.
- Great Russian Rly., Fairlie locos., 316.
- Great Southern & Western Rly., 163; cost of repairs to locos., 111; single engine, 177; A. McDonnell's loco., 178; 0-4-2 engines, 178; 0-4-4 tank locos., 179, 180; 206; c.i. wheels, 209; 0-6-4 tank loco., 237; H. A. Ivatt's compound engine, 289, 291; McDonnell's bogie, 313; E. A. Watson's 4-6-0 four-cylinder engine, 355, 360; E. A. Watson's 4-8-0 tank engine, 364, 372.
- Great Southern of Spain Rly., Kitson-Meyer loco., 317.
- Great Western Rly.—BROAD GAUGE.—Tayleur & Co.'s engines, 43, 45; "North Star" loco., 44; "Centaur" loco., 46; goods engine, "Tityos," 47; goods engine, "Leo," 47; loco. tests, 66, 67; "Great Western" loco., 68; "Iron Duke" class, 68; engines, 68; "Courier" class, 69; 0-6-0 goods engines, 69; 4-4-0 saddle tanks, 69; Gooch's bogie, 69; sledge brakes, 70; 0-6-0 tank engines, 105, 106; double bogie tank engine, 109; rebuilding of B. & F.R. tank engines, 109; D. Gooch's 4-4-0 passenger engine, 115; 2-4-0 passenger engine, 115, 116; trials of the "Great Britain" class engine, 128; speed performances, 129; locos. for the Metropolitan Rly., 153; 4-2-2 express engines, 210; Dean's tandem compound, 261; W. Dean's 2-4-0 express engines, 268, 269; W. Dean's 2-4-0 tank engine, 275; "3001" class single express engines, 291.
- Great Western Rly.—STANDARD GAUGE.—Express engine, 113; link motion for, 127; Gooch coupled

- engines, 147; Armstrong's express engine and converted goods engine, **167**; 0-6-0 saddle tanks, 174; Armstrong's express engine, **186**, 187; cabs, 177; 0-4-2 and 2-4-0 tank locos., 199, **200**; goods tanks, 205; Dean's 2-2-2 express engine, **210**; 2-4-0 engines, 213; 2-4-0 passenger tank engines, 218; W. Dean's 4-2-4 tank, 219; Armstrong's 0-6-0 goods engine, 222; 228; speed records, 229; W. Dean's tandem compound engine, **260**, **261**; W. Dean's 2-2-2 express engines, Nos. 9 and 10, **264**; W. Dean's 2-4-0 passenger engine, 266, **267**; W. Dean's 2-4-0 passenger engine, 268, **269**; W. Dean's 2-4-0 tank engine, **275**; W. Dean's 0-4-2 tank engine, **276**; trailing axle of tank loco., **276**; 0-6-0 goods engines, 279; W. Dean's 0-6-0 tender engines, 280, **281**; 0-6-0 tank engines, **280**, 281; W. Dean's bogie single express, **295**; W. Dean's 4-4-0 engines, 299, **300**; W. Dean's 4-6-0 goods engines, 307, **308**; W. Dean's bogie, 310; Belpaire fire-box, 310; De Glehn compounds, **325**; "City" and "County" classes, 4-4-0 engines, 328, **329**; 4-4-2 engines, 330; 4-6-0 engines, 331; Churchward's four-cylinder 4-4-2 engine, 332; Churchward's 4-6-2 engine, 335, **336**; Churchward's 2-6-2 tank engine, **340**; W. Dean's 2-6-0 goods engines, 342, **343**; Churchward's 2-6-0 engines, 342, **344**; Churchward's 2-8-0 goods engines, 347, **348**; 2-8-0 engines from Overseas Military Rlys., 348, **349**; Churchward's 2-8-0 tank engines, 349; rail motors, 350; Churchward's boilers, 351; top feed system, 353; "jumper" blast pipe, 353; Churchward's composite framing, 353; bogie, 353; cylinder castings, 354; piston valves, 354; C. B. Collett's "Castle" class 4-6-0 engine, 356, **361**; Churchward's 2-8-0 engine, 362, **364**; Gooch's tenders, 367.
- "Greater Britain" class compounds, L. & N.W.R., 290, **291**.
- Gregory, Sir Charles, loco. bogies, 25.
- Grendon & Co., loco. for Dublin and Drogheda Rly., 177.
- Gresham and Craven, steam sanding apparatus, 287.
- Gresley, H. N., G.N.R. 2-6-0 engines, 343, **344**; G.N.R. 2-8-0 engines, 348, **349**; pony truck, 354; valve gear, 354; G.N.R. Pacific type three-cylinder locos., 356, **362**; L. & N.E.R. 2-8-2 engine, 362, **365**; valve gear, 366; G.N.R. eight-wheeled tenders, 371.
- "Grosvenor" express loco., L.B. & S.C.R., 187.
- Gunther, W., 187.
- Hackworth, John W., Battle of the Blast-pipe, 7; remarks on the "Arrow" loco., 32; radial gear, 158.
- Hackworth, Thomas, 48, 158.
- Hackworth, Timothy, at Stephenson's works, 3; as first locomotive superintendent of the S. & D. Rly., 4; "Sanspareil" engine (1829), 13, **14**; engines with vertical cylinders, 25; "Victory" engine, S. & D. Rly., 10; "Arrow" loco., S. & D. Rly., 31; loco. for Russia, 31; mineral engines, **33**; "Dart" loco., S. & D.R., **41**; later engines for the S. & D. Rly., 48; short stroke pumps, 64; builds Hull and Selby Rly. engines, 76; "Sanspareil," 77, **78**; 92, 93; locos. for Nova Scotia, 139; blast pipe, 176.
- Hadfield & Co., 284; steel castings, 286; cast steel wheels, 286.
- Haigh Foundry, 49; locos. for the Leicester and Swannington Rly., 40.
- Hall, Samuel, smoke consuming apparatus, 131.
- Hall, —, cranks, 240; four-cylinder engine, 301.
- Harrison, T. E., patent engine, G.W.R., 43.
- "Harvey Combe" engine, 22, 35.
- Haslam, L. B., and T. H. Riches, paper on rail motors, 350.
- Haswell, John, 80; four-cylinder engine, 300.
- Hathorn, Davey & Co., 82.
- Hawkshaw, John, 142; loco., L. & Y.R., **79**.
- Hawthorn, R. & W., & Co. (later R. & W. Hawthorn, Leslie & Co., Ltd.), 47, 77, 95, 101, 118, 124, 132, 141, 149, 158, 173, 181, 183, 200, 203; "Swift" loco., S. & D. Rly., 29, **30**; "Comet" loco., Newcastle and Carlisle Rly., **30**; "Sunbeam," **31**; locos. for L. & M. Rly., 31; 2-2-2 tender engine, **36**; engine for the Newcastle and North Shields Rly., **40**; engine, Great North of England Rly., 50; engine, "Plews," Y.N. & B. Rly., **78**; Edinburgh Northern Rly. locos., 86; Crampton loco., G. & S.W. Rly., **87**, 88; express engine, Gt. Northern Rly., **92**; spring gear, **93**; coupled engines, G.N. Rly., 98; valve motion, **110**; regulator and dome, **111**; crank axle, 112; 2-4-0 express engine, G.N.R., **116**; tank engine, East Kent Rly., 120; 4-4-0 loco., Arica and Tacna Rly., **138**; engine, Copiapo Extension Rly., 139; N.E.R. 4-coupled engines, 148; G. & S.W. Rly. goods locos., **157**; loco. speed, G.N.R., 230; N.E.R. engines, 269; H. Rly. locos., **357**; tenders, 367.
- "Haystack" fire-boxes, 35.
- Heaton, —, 61.
- Hedley, Wm., applied blast pipe to Wylam-built engines (1813), 7.
- Hick, Benjamin, & Son, 42, 49, 56, 58; 0-6-0 goods engines, 82.
- Hick, John, 14.
- Highland Rly., 52; converted 4-4-0 engine and 4-4-0 express engine, **198**; D. Jones 4-6-0 goods engines, **307**; C. Cummings 4-4-0 engine, **355**; C. Cummings 4-6-0 engines, 355, **357**.
- High Peak Rly., trial of Fell loco., 319.
- Hill, A. J., G.E.R. 0-6-0 goods engine, 357; G.E.R. 0-6-2 tank engine, 363, **367**.
- Holcroft, H., lever valve gear, 357, 362.
- Holden, James, experiments on express locos., 188; modifications to 4-2-2 engines, 211; on compound engines, 254; compound goods engine, G.E.R., 257, **258**; G.E.R. 2-2-2 express engine, 264, **265**; G.E.R. 2-4-0 express engines, 267, **268**; 2-4-2 tank engines, 277; G.E.R. single express engine, **295**; G.E.R. 2-4-0 engines, 296, **297**; G.E.R. 2-4-2 tank engines, **305**; oil fuel apparatus, 311; G.E.R. 4-4-0 engines, "1900" class, 329, **330**; G.E.R. three-cylinder 0-10-0 tank engine, **337**.
- Holden, Stephen D., G.E.R. 4-6-0 engines, 332, **333**.
- Holmes, Matthew, N.B.R. 4-4-0 engines, **272**.
- Holt, F., air sanding apparatus, 287.
- Hookham, J. A., N.S.R. four-cylinder 0-6-0 engine, 364, **376**.
- Hopkins, Gilkes & Co., 173.
- "Horse-leg" motion, J. Gray's, 43.
- Horwich Works, 277.
- Howell & Co., 206.
- Howrah Terminus, E.I.R., engine at, 142.
- Hoy, H. A., L. & Y.R. four-cylinder compound engine, 292; L. & Y.R. boilers with corrugated flues, 351.
- Hudswell, Clarke & Co., 4-8-0 engines for Londonderry and Lough Swilly Rly., 348.
- Hughes, George, L. & Y.R. four-cylinder compound 0-8-0 engine, 326; L. & Y.R. four-cylinder

- engines, 332; L. & Y.R. 2-6-2 tank engines, 340; L. & Y.R. 0-8-2 tank engines, 349, **350**; paper on boilers, 351-2; superheaters, 352; L. & Y.R. piston valves, **352**, 354; bogie brakes, 353; L. & Y.R. 4-6-0 four-cylinder engines, 355, **358**.
- Hull and Barnsley Rly., tank loco., 284.
- Hull and Selby Rly., locos. for the, **49**, 61, **76**; John Gray's engines, 42, **76**.
- Hunt, Thomas, 61.
- Hurst's, J., engine, L. & Y.R., **79**.
- Hydraulic brake, 220.
- Imperial Japanese Rlys. locos., 237, 238, 321.
- Inchicore Works, 179, 237.
- India, Compound locos. in, 327; Dübs's metre gauge tank loco. for, **239**; Branch Railway loco., **181**, 182.
- Indian Midland Rly., Worsdell compounds, 327.
- Indian Railways, locomotives for, 180; metre gauge locos., 238, **240**; standardization of locos. for, 241.
- Indian State Rlys., 0-6-0 goods engines, 238, **240**; "O" class 4-4-0 engines, 240, **241**, 242.
- India Rubber hydro-pneumatic springs, 110.
- Injectors, 207.
- Injector, Giffard's, 166.
- Inspection engine, 84.
- Institution of Civil Engineers, 243, 273, 311, 327.
- Institution of Locomotive Engineers, 313.
- Institution of Mechanical Engineers, 241, 243, 310, 326, 352; F. W. Webb's paper, 248; Inst. of Mech. Engrs. (1872), 284; ditto (1886), 327; ditto (1906), 350, 353; ditto (1906-9), 351-2; ditto (1910), 327.
- Intermediate driving shaft locomotives, 86.
- Interoceanic Rly. of Mexico, Beyer, Peacock engines, 313.
- Intercepting valve for compounds, 258.
- "*Invicta*," C. & W. Rly., **17**.
- Ireland, combined locos. and carriages for, 84; tank locos. for, 90; locos. for Ireland and overseas, 177, 237.
- Irish Railways, compound engines for, 257.
- Italy, Stephenson locos. for, **137**.
- Ivatt, Henry A., rebuilt 0-4-2 engines, G.N.R., 172; G.S. & W.R. compound loco., 289, **291**; G.N.R. 4-2-2 express engines, 295, **297**; G.N.R. 4-4-0 engines, **300**; G.N.R. 4-4-2 express engine, 301, **303**; G.N.R. 4-4-2 tank locos., 305; G.N.R. 0-8-0 mineral engine, **308**, 309; G.N.R. four-cylinder compound 4-4-2 engines, 325, **326**; G.N.R. 4-4-2 engines, 330, 331; G.N.R. four-cylinder 4-4-2 engine, 332; G.N.R. 0-8-2 tank engines, 348; reversing gear, 354.
- Jackson, P. R., 163.
- Jamaica, Sharp Bros., locos. for, 140.
- Jamalpur Works, E.I. Rly., engine at, **141**.
- "*James Spooner*," Fairlie loco., Festiniog Rly., 314, **315**.
- Japanese Rlys., Imperial, locos. for, 237, 238, 321.
- "*Jeanie Deans*," L. & N.W.R. compound loco., 251.
- Jenkins, W., tank engines for L. & Y. Rly., **122**; coal burning fire-box, 134.
- "*Jenny Lind*" type engines, 76, **77**; trials, 129; Wilson's dimensions, 130.
- Jessop, —, 63.
- "*John Hick*" class, L. & N.W.R., compound engines, 291.
- Johnson, Samuel W., 208; crank axle, 112; G.E.R. 2-4-0 engines, 170, **171**; G.E.R. 4-4-0 express engines, **197**; Midland and G.E. 0-4-4 tank engines, 200, **201**; Midland Rly. 2-4-0 engines, 211, **212**; Midland Rly. 4-4-0 engine, **213**; Midland Rly. 4-4-0 engine, **214**; Midland Rly. 0-6-0 goods engine, **221**; Midland Rly. 4-2-2 express engines, **266**; Midland Rly. "1667" and "1740" classes 4-4-0 engines, 269, 270; Midland Rly. 0-4-4 tank engines, 277; boilers, 284; frames, 285; cast steel wheels, 286; cast eccentric sheaves, 286; Midland Rly. single express engines, 295; Midland Rly. 4-4-0 "2183" and "60" class express engines, 297; Midland Rly. proposed tank engines, 305; Midland Rly. compounds, 322, **323**; G.E. & M. Rlys. tenders, 367; M.R. tenders, 369; M.R. bogie tenders, 371.
- Jones and Potts, 55, 56, 62, 77, 83, 90; London and Blackwall Rly. engines, **83**.
- Jones, Chas., Metropolitan Rly. 4-4-4 tank loco., 363, **369**.
- Jones, David, 4-4-0 engines, Highland Rly., **198**; Highland Rly. engines, 300; Highland Rly. 4-6-0 goods engines, **307**.
- Jones, Turner and Evans, 47.
- Joy, David, 105; valve gear, 221, 226, 244, 273, 292, 297, 365; crank axle, 112; stays, 126; valve gear on G.W.R. engine, 280.
- "Jumper" blast-pipe, G.W.R., 353.
- Kearsley- (Midland Counties Rly.), 58.
- Kerr, Stuart & Co., Met. Rly. 4-4-4 tank locos., 363, **369**.
- Kershaw, J., G.I.P. Rly. locos., **181**.
- Kessler, E., 80, 181, 218.
- Killingworth colliery engines, 1, 3, 7, 10.
- Kilmarnock Works, 196, 212, 272; first engine built at, **114**, 115.
- Kirtley, Matthew, 82, 100, 113, 135; details, 110; valve motion, 127; Midland Rly. express engine, **147**; Midland Rly. goods loco., 157, **158**; tank locos., 159; boilers, 165; 2-4-0 Midland Rly. engine, **170**; cabs, 177; M.R. 2-4-0 express loco. "800" class, **189**, **190**; Midland Rly. 2-4-0 express loco. "890" class, **190**; Midland Rly. 0-4-4 tank loco., 200; goods loco., Midland Rly., **202**; bogie, 212; blast-pipe, 285.
- Kitching, W. & A., engines for S. & D. Rly., 33; loco. "*Raby Castle*," 36, **39**; engine "*Queen*," 40, **41**; tires, 163; loco. "*Derwent*," **48**.
- Kitching, Alfred, loco. "*Woodlands*," S. & D. Rly., **57**.
- Kitching, John, N.E.R. (S. & D. section), loco., **195**.
- Kitson & Co., 141, 145, 153, 181, 203; compensating lever, **127**; locos. for G.I.P. Rly., **140**; engines for East Indian Rly., **141**; locos. for Madras Rly., 142; Naylor safety valve, **176**; engines for Queensland, **183**; G.I.P. locos., 183; G.E.R. engines, 211; M.R. engines, 213; L. & Y.R. 0-4-4 tank engines, **218**; L. & Y.R. 0-6-2 tank engines, **220**; Imperial Japanese Rlys. and Natal Govt. Rlys. locos., 238, **239**; G.N. of S. Rly. engines, 272; G.E.R. goods engines, 279, **280**; Mersey Rly. engines, **284**; Cardiff Rly. tank loco., **284**; twin tank loco., Cape Govt. Rlys., 313; Anglo-Chilian N. & R. Co. and Transandine Rlys. locos., **316**; 2-8-0 engines for Government, 347; S.E. & C. Rly. rail motors, 350; Furness Rly. 4-6-4 tank loco., 363, **369**.
- Kitson-Clark, Lieut. Colonel E., 313.
- Kitson, J., Hawthorn, valve gear, 284.
- Kitson-Meyer locos., 316; Gt. Southern of Spain Rly., 317; Anglo-Chilian Nitrate and Railway Co., **316**; Transandine Rly., **316**.

- Kitson, Thompson & Hewitson, and Kitson & Hewitson, 54, 56, 84, 90, 99, 101, 102, 110; Midland Rly. engine, 54; Crampton engine, 72, 73; Leeds and Thirsk Rly. engine, 80, 81; 0-6-0 goods engine, 82; Leeds, Bradford and Halifax Rly. loco., 151, 152; "Bloomer" express engines, L. & N.W.R., 94; engine, Copiapo and Caldera Rly., 138.
- Knott End Rly., Manning, Wardle & Co., tank loco., 399.
- Krauss & Co., 112, 225, 287.
- Krupp axles, 165; tires, 127, 163.
- "Lablache" Crampton loco. by E. B. Wilson & Co., 84.
- La Chapelle Works, 274.
- "Lady of the Lake" class, L. & N.W.R., 144.
- Lancashire and Yorkshire Rly. loco., 79; goods engines, 102; 0-6-0 saddle tanks, 122; Jenkins fire-box, 134; axles, 165; 176; 0-4-4 tank engines, 218; 0-6-2 tank engines, 220; Newark brake trials, 230, 235; Sir J. Aspinall's 4-4-0 engines, 273; Aspinall's 2-4-2 tank engines, 277, 278; Sir J. A. F. Aspinall's 0-6-0 goods engine, 280; H. A. Hoy's four-cylinder compound engine, 292; Sir J. Aspinall's 4-4-0 engines, 296, 298; Sir J. Aspinall's 4-4-2 engines, 303, 304; Sir J. Aspinall's 0-8-0 engines, 308; Belpaire fire-box, 310; smoke-box superheater, 311; experiments with steam jackets, 311; 4-4-2 engines, 331 G. Hughes's four-cylinder compound 0-8-0 engine, 326; four-cylinder 4-6-0 engines, 332; 2-6-2 tank engines, 340; G. Hughes's 0-8-2 tank engines, 349, 350; rail motors, 350; H. A. Hoy boilers with corrugated flues, 351; Druitt-Halpin's boiler, 352; G. Hughes's superheaters, 352; G. Hughes's piston valves, 352, 354; bogie brakes, 354; G. Hughes's 4-6-0 four-cylinder engines, 355, 358; water pick-up apparatus, 369; eight-wheeled tender, 371.
- "Lancashire Witch" loco., Bolton and Leigh Rly. (1828), 9; 131.
- Lange and Livesey's patent twin locos. for Mexico, 313; rack loco., Puerto Cabello and Valencia Rly., 320.
- Le Chatelier, 62; 188; brakes, 209.
- Leeds and Thirsk Rly., Kitson T. & H. passenger engine, 80, 81; goods engine, 82.
- Leeds, Bradford and Halifax Rly. loco., 151, 152.
- Leicester and Swannington Rly. goods engine, 24, 25; engines, 40, 82.
- Leitzmann, F., experiments on express locos., 188; 228.
- Lentz boilers, 351.
- Link motion, 63; first engine fitted with, 54; Hawthorn's, 110.
- Lickey incline, working of the, 42; banking engine for the, 59; tank locos. for, 159; Sir H. Fowler's 0-10-0 engine, 363, 366.
- Lister, Wm., engines for the S. & D. Rly., 33.
- Little Bytham accident, G.N.R., 294.
- "Little" North Western Rly., Fairbairn's tank loco., 90, 91.
- Liverpool and Manchester Rly., first multitubular boiler, 10; "Rocket" loco. (1829), 11; "Liverpool" engine, 18; Rainhill trials, 12 *et seq.*; "Sanspareil" engine (1829), 13, 14; engine "Novelty" (1829), 14, 15; "Northumbrian" loco. (1830), 16, 17; "William the Fourth" engine (1830), 17; "Planet" (1830), 19, 20; "Samson" and "Goliath" goods engines (1831), 20, 21; engine "Patentee" (1833), 22, 23; Galloway's loco., 27; passenger locos., 31; Sharp, Roberts & Co.'s engine, 28, 29; Forrester's engine, 30; expansion gear, 43; fuel consumption, 65, 67; locos., 34; boilers, 36; "Bird" class engines, 50, 51; locos., 60; Act for, 131, 132.
- "Liverpool" engine, Bury's (1830), L. & M. Rly., 18.
- "Liverpool" loco., L. & N.W.R., 71, 72.
- Llanelly Rly. goods loco., 158, 159; 0-8-0 tender loco., 160.
- Locke, Joseph, 62.
- "Locomotion No. 1," Stockton and Darlington Rly. (1825), 1, 2.
- Locomotive performances, 128, 228.
- Locomotives with four cylinders, 332.
- Locomotive with multiple single acting cylinders, 343, 345.
- London and Birmingham Rly., Bury's locos. for the, 34; locos., 66, 67.
- London and Blackwall Rly. tank engine, 83.
- London and Croydon Rly., locos. for the, 33; G. and J. Rennie's engine, 41, 42.
- London and Greenwich Rly., Forrester's engine, 30; 83.
- London and North Eastern Rly., Museum at York, 204; Garratt loco., 318, 319; 4-4-0 engines, "Director" class, 329, 330; G.C.R. 4-6-2 tank engine, 341; bar-framed engine bogie, 353; H. N. Gresley's Pacifics, 356, 362; H. N. Gresley's 2-8-2 engine, 362, 365; 0-6-2 tank engine, 363, 367; booster, 365.
- London and North Western Rly., 154, 156, 207; friction wheel coupling, 32; "Crewe" type passenger engine, 52; Southern Division, Stephenson's passenger engine, 55; Crampton engines "Liverpool" and "Courier," 71, 72; engine "Cornwall," 73, 74; Stephenson's engine, 74, 75; trials of three-cylinder loco., 75; McConnell's loco., 79; Sharp's goods engines, 81; test of goods engine, 82; Southern Division, 82; Sharp's tank locos., 91; converted tank locos., 92; J. E. McConnell's express engines, 94; "Small Bloomer" engines, 94, 95; W. Fairbairn & Sons and E. B. Wilson & Co.'s express locos., 95. Northern Division: express engines, 97. Southern Division: McConnell's goods engines, 102; smoke-box doors, 111. North Eastern Division: 112; Trevithick's 2-4-0 tank engine, 121; J. Ramsbottom's D.X. goods engines, 122; engines with Allan gear, 127; trials of "Bloomer" and "Crewe" engines, 130; running of "Times" special, 130; train speeds, 130; "Lady of the Lake" class, 144. S. Division: McConnell's express engines, 145, 146; McConnell's tank engine, 151; tires, 163; axles, 165; steel boilers, 166; Ramsbottom's 2-4-0 engines, 169; F. W. Webb's 2-4-0 express engines, 192, 193; "Charles Dickens" loco., 195; Webb's coal engines, 204; steel fire-boxes, 206; counter pressure brake, 209; c.i. wheels, 209; Webb's 2-4-0 and 2-4-2 tank engines, 219, 220; Webb's 0-6-0 goods engines, 221, 222; 0-4-0 shunting engine, 224, 225; circular slide valves, 226; first engine to have Joy's gear, 226; speed records, 230, 236; Newark brake trials (train, 230, 235; coal consumption, 233; "Experiment" class, compound locos., 243, 244; "Compound" class locos., 243, 244; "Dreadnought" class, compound locos., 245; "Teutonic" class,

- compound loco., **246**; compounds, curves of crank efforts, **249**; Webb compound tank engines, **252, 253**; "*Precedent*" class 2-4-0 engines, **266**; 2-4-2 tank engines, **278**; cast steel wheels, **286**; "*Greater Britain*" class compounds, **290, 291**; "*John Hick*" class compounds, **291**; 0-8-0 mineral engines, **291**; Webb's four-cylinder compound express engines, **292, 293**; F. W. Webb's triple expansion engines, **293**; F. W. Webb's 2-4-0 engines, **295**; F. W. Webb's four-cylinder non-compound engine, **301**; F. W. Webb's 0-6-2 tank engines, **306**; F. W. Webb's 0-8-0 mineral engine, **308**; F. W. Webb's bogie truck, **311**; four-cylinder compound 0-8-0 engine, **324**; "*Alfred the Great*" class compounds, **324**; four-cylinder 4-6-0 compounds, **324**; 4-4-0 engines, G. Whale's and C. J. Bowen-Cooke's, **328, 331**; C. J. Bowen-Cooke's "*George the Fifth*" 4-4-0 engines, **330, 331**; "*Prince of Wales*" class 4-6-0 engines, **331**; four-cylinder 4-6-0 engine, **332, 335**; Webb's three-cylinder simple engine, **336**; 0-8-0 goods engine, **346**; G. Whale's 4-6-0 goods engines, **346**; C. J. Bowen-Cooke's 0-8-2 tank engines, **349**; rail motors, **350**; C. F. Dendy Marshall's valve gear, **365**; tenders, **366-7**; J. E. McConnell's tenders, **368-9**; water pick-up apparatus, **369**.
- London and South Western Rly., **156, 171**; engines, **43**; double ported slide valves, **63**; speeds, **67**; outside cylinder engines, **79**; express engines, **97**; J. Beattie's 2-4-0 engine, **98**; J. Beattie's goods engine, **99**; "*Canute*" class loco., **114**; J. Beattie's 2-4-0 express engine, **116, 117**; feed-water heating apparatus, **126**; Beattie's boiler, **133, 134**; J. Beattie's tank loco., **152**; running of coupled engines, **188**; W. G. Beattie's 4-4-0 engines, **215**; W. Adams's 4-4-0 engines, **216, 217**; Adams's 4-4-0 and 4-4-2 tank engines, **220**; W. Adams's two-cylinder compound engine, **255**; W. Adams's 0-4-2 engine, **274, 275**; Adams's 4-4-2 tank engines, **278**; W. Adams's 4-4-0 express engines, **296, 298**; D. Drummond's 4-4-0 engines, **299**; D. Drummond's four-cylinder engine, **301, 303**; 4-4-0 engines, **328**; 4-4-0 engines, **330**; D. Drummond's four-cylinder 4-6-0 engines, **332**; R. W. Urie's 4-6-0 goods engines, **346**; Drummond's rail motors, **350**; D. Drummond's steam dryer and feed-water heater, **352**; D. Drummond's 4-4-0 engines, **355**; R. W. Urie's 4-6-0 engines, **355, 356**; R. W. Urie's 4-6-2 tank engines, **363, 368**; J. Beattie's tenders, **368-9**; R. W. Urie's 4-8-0 shunting engines, **364, 370**; D. Drummond's bogie tenders, **371**.
- London, Brighton and South Coast Rly., **134**; Bodmer's engine, **61, 62**; John Gray's engines for the, **76**; Crampton locos., **88**; Craven's tank loco., **120, 121**; pumps, **166**; Craven's 0-4-4 tank engine, **172**; Stroudley's "single" express engine, **187**; Stroudley's 2-4-0 express loco., **191, 192**; Stroudley's 0-4-2 tank locos., **199, 275**; Stroudley's 0-6-0 tank engines, **201, 202**; Stroudley's goods engines, **203, 279**; Stroudley's 0-4-2 engines, **217**; 4-4-2 tank locos., **226**; Newark brake trials, **285**; Stroudley's 0-4-2 express engine, **273, 274**; 4-4-2 engines, **330**; D. E. Marsh's 4-4-2 engines, **330**; D. E. Marsh's 4-6-2 tank engines, **340**; L. B. Billinton's 4-6-4 tank engines, **341**; L. B. Billinton's 2-6-0 engines, **343**; rail motors, **350**; W. Stroudley's tenders, **367-8**.
- London, Chatham and Dover Rly. (formerly East Kent Rly.), **134, 151**; Crampton's express engines, **87, 88**; 4-4-0 tank engines, **120**; Sharp, Stewart & Co.'s 2-4-0 engine, **147**; 4-4-0 engines, **149, 150**; tank loco., **155**; goods loco., **157, 158**; tank engines, **161**; axles, **165**.
- London-Edinburgh Scotch express (1888) race, **265**; (1895), **251**.
- London Exhibition (1862), **143, 146**; loco. for Egypt, **157, 158**.
- London, Midland and Scottish Rly., 2-4-0 engines, **170**. Tilbury Section: **305**; compounds, **323**; 0-6-0 goods engines, **342**; G. Hughes's 4-6-0 four-cylinder engines, **355, 358**; H. P. M. Beames's 0-8-4 tank engine, **364, 370**.
- London, Tilbury and Southend Rly., 4-4-2 tank engines, **218, 219**; T. Whitelegg's 4-4-2 tank loco., **305**; T. Whitelegg's variable blast-pipe, **353**.
- Londonderry and Enniskillen Rly., engine and carriage for, **84**.
- Londonderry and Lough Swilly Rly., 4-8-0 tender engines, **348**.
- Long Boiler engines, **53**.
- Longridge, J. A., on blast-pipes, **177**.
- Longridge, R. B., & Co., **47, 54**; G.E.R. Crampton's locos., **86, 87**.
- Lower Silesian Rly., Wöhler's axle-box, **160**.
- Lubricators, **366**; Roscoe's, **166**.
- Lyons and St. Etienne Rly., steam tender loco., **160**.
- Macallan's blast pipe, **310**.
- Macclesfield Branch Line, locos. for, **83**.
- McConnell, J. E., **42, 59, 82, 100, 140**; L. & N.W. Rly. loco., **79**; L. & N.W.R. express engines, **94**; "Small Bloomer" engines, L. & N.W.R., **94, 95**; express locos., L. & N.W.R., **95**; fire-box, **102**; goods engines, L. & N.W.R., **102**; boiler, **132, 133**; express engines for L. & N.W.R., **145, 146**; tank engine, L. & N.W.R., **151**; L. & N.W. tenders, **368-9**.
- McDonnell, A., **206**; cost of repairs, **114**; locos. for G.S. & W.R., **178**; tank locos. for G.S. & W.R., **179, 180**; axle-boxes, **226**; 0-6-4 tank loco., **237**; N.E.R. 4-4-0 engines, **266**; N.E.R. 4-4-0 engines, **269**; steel castings, **286**; bogie, **313**.
- McIntosh, J. F., Caledonian Rly. 4-4-0 engines, **298, 299**; 4-6-0 C.R. express engines, **332, 335**; C.R. 4-6-0 goods engines, **342**; Caledonian Rly. engines, **346**; C.R. 0-8-0 goods engines, **346, 347**; spark arrester, **353**; C.R. tenders, **371**.
- "*Mac's Mangle*," L. & N.W.R., **79, 80**.
- Madras Rly., locos. by Kitson & Co., **142**.
- Maffei, J. A., **80, 137, 240**.
- Main line and express passenger tank engines, **218**; goods tank locos., **205**.
- "*Majestic*" class locos., Stockton and Darlington Rly., **26**.
- Malcolm, B. B. & N.C.R. two-cylinder compound loco., **289, 290**.
- Malines-Terneuzen Rly., 2-4-0 engine, **237, 238**.
- Mallet, Anatole, two-cylinder compound system, **243, 250, 317**; compound engines, **317**.
- "*Mammoth*" class goods engines, **58**.
- Manchester and Birmingham Rly., Sharp's tank locos., **83**.
- Manchester and Bolton Rly. locos., **34**; fire-boxes and tubes, **36**.
- Manchester and Leeds Railway, goods engines, **24**.
- Manchester, Sheffield and Lines. Rly., **151, 163**; Sharp's goods engine, **81**; fire-box, **101**; Sharp's goods engine, **101**; Peacock's experiments, **114**; ditto, **124**; steam tender loco., **160**; cabs, **177**; C. Sacré's 4-4-0 engine, **214, 215**; C. Sacré's

- 0-6-0 goods engine, 222, **223**; C. Sacré's single express engines, **263**; T. Parker's 2-4-0 express engines, 267, **268**; T. Parker's 2-4-2 tank engines, 277; Belpaire fire-box, 310.
- Manning, Wardle & Co., tank engines, 91; 2-6-0 tank loco., Knott End Rly., 309; Fell locos. for the Cantagallo Rly., 319.
- Manson, J., G.N. of S. Rly. 4-4-0 express engines, 272, **273**; G. & S.W.R. 4-4-0 engines, 298; G. & S.W.R. four-cylinder engine, **301**; G. & S.W.R. 4-4-0 engines, 330; G. & S.W.R. 4-6-0 engines, 331, **333**; G.N. of S. Rly. tenders, 371. "*Marchioness of Stafford*" compound loco., L. & N.W. Rly., 245.
- Markham, Charles, experiments, 134, 135.
- Marseilles-Avignon Rly., 58.
- Marsh, D. Earle, L.B. & S.C. Rly., 4-4-2 engines, 330; L.B. & S.C. Rly. 4-6-2 tank engine, **340**; L.B. & S.C. Rly. superheaters, 352.
- Marshall, C. F. Dendy, valve gear on L. & N.W.R. loco., 365.
- Marshall, H. P., 130.
- Marshall, J. T., valve gear, 354.
- Marshall, W. P., 63, 132, 163, 175; tires, 127.
- Marten, C. Rous, 129, 188, 228, 229, 230, 231, 232, 251, 263, 264, 294, 312.
- Martley, Wm., locos. for L.C. & D. Rly., 88, 150.
- Maryport and Carlisle Rly., 163; steel fire-boxes, 166; steel boilers, 166.
- Mather, Dixon & Co., locos. for L. & M. Rly., 31; locos., 35, **36**; engines for the G.W.R., 43.
- Maunsell, R. E. L., top feed system, 353; reconstructed S.E. & C. Rly. 4-4-0 engines, 355; S.E. & C. Rly. three-cylinder 2-6-0 engines, 357; S.E. & C. Rly. 2-6-4 tank engine, 363, **368**; pony trucks, 364.
- Mauritius Rlys., 0-8-0 tank loco., **182**, 183.
- Maw, Dr. W. H., 166, 180.
- Melling, John, 60; introduces ball clacks, 24; patent for friction wheels, 32.
- Mersey Rly., Beyer, Peacock & Co.'s 0-6-4 and 2-6-2 tank locos., **283**.
- Metallic packing, 287.
- Metre Gauge Rlys., India, 238.
- Metropolitan Rly., 163; G.W.R. broad-gauge locos. for, **153**; Beyer, Peacock tank with condensing gear, 155, **156**; tank engine, 162; Burnett's 0-6-0 tank loco., **174**; C. Jones's 4-4-4 tank loco., 363, **369**.
- Mexican Rly., Fairlie locos., **314**, **315**.
- Meyer type, prototype of, 137; locomotives, 316.
- Midland and S. Western Junction Rly., 4-4-4 tank engines, 305; Beyer, Peacock & Co.'s 2-6-0 engines, 306.
- Midland Counties Rly. locos., 34; 58; trials of the "*Bee*" engine, 131.
- Midland Gt. Western Rly. locos., 179; Atock's boiler, 284.
- Midland Rly., 58, 82, 100, 101, 156; Kitson, Thompson & Hewitson's engine, 54; tests, 66; Crampton engine, 72, **73**; Kitson's goods engines, 82; Stephenson's locos., **93**, 94; Sharp's engines, **93**, 94; coal engines, 104; smoke-box doors, 111; crank axle, 112; single driver express engine, **113**; 2-4-0 express engine, 116; goods engine, Beyer, Peacock & Co., **124**, 125; link motion for, 127; trials of single engines, 129; coal burning engines, 134; fire-door and brick arch, **135**; evaporation tests, 136; M. Kirtley's express engine, **147**; goods loco., 157, **158**; tank locos., 159; tires, 163, 164; boilers, 165; Kirtley's 2-4-0 engines, **170**; cabs, 177; running of coupled engines, 188; M. Kirtley's "800" class 2-4-0 express locos., **189**, **190**; "890" class 2-4-0 express loco., **190**; Pullman cars, 191; Kirtley's 0-4-4 tank loco., 200; Johnson's 0-4-4 tank engines, 200, **201**, 277; Kirtley's goods loco., **202**; tubes, 208; S. W. Johnson's 2-4-0 engines, 211, **212**; S. W. Johnson's 4-4-0 express engine, **213**; Johnson's 4-4-0 engine, **214**; S. W. Johnson's 0-6-0 goods engines, **221**; brake trials on the, 230, 235; "890" class speeds, 230, 235; speeds, 232; "800" class speeds, 233; coal consumption, 233, 236, 259; S. W. Johnson's 4-2-2 express engines, **266**; 295; S. W. Johnson's "1667" class 4-4-0 engines, 269; "1740" class 4-4-0 engines, 270; S. W. Johnson's 4-4-0 engines "2183" and "60" class, 297; proposed 4-4-4 tank engine, 305; Smith's compound engines, 322, **323**; R. M. Deeley's 4-4-0 engine, 329; Sir Henry Fowler's 0-6-0 goods engines, 341; Sir C. Paget's 2-6-2 engine, 343, **345**; Sir H. Fowler's 0-10-0 engine, 363, **366**; tenders, 367; 369; S. W. Johnson's tenders, 371.
- Midland Rly. Northern Counties Committee, compound locos., 289, 306; tenders, 367.
- Miles Platting Works, L. & Y.R., 122.
- Mineral engines, 0-4-2 type, 118.
- Miscellaneous locos., 84.
- Mixed traffic 0-4-2 engines, 99; ditto 4-coupled, 171; goods and mineral engines, 357.
- Monkland and Kirkintilloch Rly. engines, 11.
- Monmouthshire Rly., Sharp Bros. tank loco., **103**, 104; tank locos. by Stothert & Slaughter, 105, **107**; 4-4-0 tank engine, 119.
- Mont Ceniz Rly., Fell locos., 319.
- Morrison, J., & Co., 181.
- Morton valve gear, 287.
- Moorsom, Captain, 42.
- Motion, etc., 38, 175, 208.
- Motion plates, frame stays, brackets, etc., 286.
- Motion and valve gears, 354; 365.
- Multi-cylindred uncoupled engine, 62.
- Murdock & Aitken, locomotives for Monkland Rly., 11.
- Namur & Liège Rly., locos., 70, **71**.
- Nasmyth, Gaskell & Co., 42; 45, **46**, 47; goods engine, G.W.R., **47**.
- Nasmyth, Wilson & Co., 0-4-2 and 0-4-4 metre gauge engines for India, **239**; New Zealand Govt. Rlys. engines, 321; 2-8-0 engines for War Office, 348.
- Natal Govt. Rlys., Kitson & Co.'s loco., 238, **239**.
- Navigation incline, Taff Vale Rly., 159.
- Naylor safety valve, **176**.
- Naylor, Vickers & Co., tires, 163; axle steel, 165.
- Neath & Brecon Rly., Fairlie engine "*Progress*," 315.
- Neilson & Co., 41, 117, 172, 180, 183, 200, 218, 274, 300; Cowlairs incline engine, **60**; tank loco. for Edinburgh and Glasgow Rly., 89, **90**; Dublin and Drogheda Rly. loco., 90, **91**; Eastern Counties Rly. goods loco., **118**; 0-4-2 mineral engine, 118, **119**; single cylinder loco., 125, **126**; engines for Egypt, 143; tank loco. for Eastern Counties Rly., **154**; L.C. & D.R. tank loco., **155**; 2-4-0 engine, Caledonian Rly., **171**; loco. for Dundalk and Enniskillen Rly., 178, **179**; G.I.P.R. tank loco., **182**, 183; Grand Trunk Rly. locos., 183; Midland Rly. 2-4-0 loco., **189**; N.E.R. express loco., **191**; N.E.R. 0-4-4 tank loco., **200**; Caledonian Rly. 0-4-4 tank engine, **201**; Midland Rly. tank engines, 200, **201**; M.R. engines, 211; N.B.R.

- engines, 213, **214**; Caledonian Rly. 4-4-0 engines, 216; L. & S.W.R. 4-4-0 engines, **216**; N.B.R. 4-4-0 tank engines, 218; G.E.R. 2-6-0 goods engines, **222, 223**; steam tender locos. for Spain, 237; South Indian Rly. engine, 239; S. Indian & Eastern Bengal Rly. engines, 239, 242; S. Mahratra Rly. 2-6-0 engines, 240; 4-2-2 engine for Caledonian Rly., **265**; Caledonian Rly. engines, 271; L. & S.W.R. tank locos., 278; twin locos. for N. Western Rly. of India, 314; Fairlie loco. for Mexican Rly., **315**; Fell locos. for New Zealand, **320**; Worsdell compounds for India, 327.
- Nesbit's, W. H., four-cylinder tandem compound, N.B.R., **259, 260**.
- Neville, Jas., patentee of first multitubular boiler (1826), 10.
- Newark brake trials, speeds at, 230, 235.
- Newcastle and Carlisle Rly. loco., "*Comet*," **30**.
- Newcastle and North Shields Rly., Hawthorn's engine for the, **40**.
- New Orleans Rly., locos. intended for, 45.
- New South Wales, locos. for, 58, **139, 140**.
- New South Wales Rlys., Stephenson's locos., 238; Beyer, Peacock's three-cylinder compounds, **293**.
- New York and Providence Rly. locos., 31.
- New Zealand Govt. Rlys., Fell locos., 319, **320**; Nasmyth, Wilson & Co.'s engines, 321.
- Nicholson, John, compound loco., 88, **89**; steam jet, 131.
- Nilgiri Rly., rack engines, 321.
- Nine Elms Works, 98, 274.
- Norris engines, Birmingham and Gloucester Rly., **42, 59, 119**.
- North British Loco. Co., Mallet loco. for S. Africa, **317**; rack engines, 321; Bengal-Nagpur Rly., De Glehn compounds, 328; N.B.R. 4-4-2 engines, 330; G. & S.W.R. 2-6-0 goods engines, 342, **343**; 2-8-0 engines for War Office, 347; C. Rly. locos., 357; L. & N.E.R. engines, 357; G. & S.W.R. 4-6-4 tank engines, 364, **372**; C.R. 4-6-2 tank loco., 364, **371**.
- North British Rly. 0-6-0 passenger tank engines, 175; T. Wheatley's 4-4-0 express engine, 195, **196**; cast iron wheels, 208; D. Drummond's 4-4-0 express engines, 213, **214**; Drummond's 4-4-0 tank engines, 218; W. H. Nesbit's four-cylinder tandem compound, **259, 260**; M. Holmes's 4-4-0 engines, **272**; Drummond's 0-4-2 tank engines, 275; W. P. Reid's 4-4-2 locos., 330, **331**; tenders, 368.
- North Eastern Rly., 100, 163; three-cylinder loco., 76; Stephenson & Co.'s goods engines, 104; E. Fletcher's express engines, 148; 4-4-0 engines for Whitby line, **150**; goods engines, 158; reversing gear, 175; Fletcher's "901" class express locos., **191**. S. & D. Section: 2-4-0 loco., **195**; W. Bouch's 4-4-0 engine, **197**; Fletcher rebuilt 2-4-0 engines, 198; Fletcher's 0-4-4 tank loco., **200**; goods locos., 203; coupling rod joint, **208**; E. Fletcher's 0-6-0 goods engines, 221, **222**; Newark brake trials train, 230, 235; coal consumption, 234; T. W. Worsdell's compound 2-4-0 and 4-4-0 engines, **254**; T. W. Worsdell's 4-2-2 compound engine, **255, 256**; 0-6-2 compound tank engine, 257, **258**; 0-6-0 compound goods engine, **257**; 4-4-0 compounds, performances of, 259; compounds speeds, 259; W. Worsdell converts compounds to simple, 260; A. McDonnell's 4-4-0 engines, 266, 269; the "Tennants" 2-4-0 express engines, 266, **267**; T. W. Worsdell's 2-4-2 tank engines, 277; T. W. Worsdell's bogie, 286; W. Worsdell's two-cylinder compound engine, **289**; W. M. Smith's system three-cylinder compound engine, 289, **290**; W. Worsdell's rebuilt 4-2-2 express engine, 295, **296**; W. Worsdell's 4-4-0 engines, 297, 298, **299**; W. Worsdell's 4-6-0 express engines, **304**; W. M. Smith's four-cylinder compound 4-4-2 engines, 326, **327**; W. Worsdell's 4-4-0 engines, 329; W. Worsdell's 4-4-2 engines, 330, **332**; 4-6-0 engines, 331; Sir V. Raven's three-cylinder Atlantic type engine, **336, 337**; W. Worsdell's 3-cylinder, **338, 339**; Sir V. Raven's 3-cylinder tank engines, **339**; 4-6-0 tank engines, 340; W. Worsdell's 0-8-0 goods engines, 346; 4-6-0 goods engines, 346, **347**; spiral bearing springs, 353; Stumpf uniflow loco., 354; Sir V. Raven's Pacific type locos., 356, **363**; uniflow Atlantic type engine, 357; 4-6-0 and 0-8-0 engines, 362; tenders, 367; Sir V. Raven's self-trimming tenders, 371.
- Northern and Eastern Rly., long boiler engine, **53**.
- North London Rly., 134, 153, 163, 207; four-coupled tank locos., 105; 4-4-0 tank engines, 119, **120**; 4-4-0 tank locos., **156, 157**; W. B. Adams's experiments, 161; 4-4-0 tank engine, 172, **173**; W. Adams's sand-box, 177; J. C. Park's 0-6-0 tank loco., **282**.
- North Midland Rly., 63, 67; goods engines, 24; passenger locos., 34; mail engine, **35**; engine, 54.
- North Staffs. Rly., locos. fitted with wedge gear, 63; J. A. Hookham's four-cylinder 0-6-0 engine, 364, **370**.
- "*North Star*" broad gauge loco., G.W.R., **44, 45**.
- Northern Counties Committee, compound engines, 289; compound tank locos., 306; tenders, 367.
- Northern Rly. of France, 228; 0-4-2 express engine, 274.
- Northern Rly. of Spain, 184.
- "*Northumbrian*" locomotive, Liverpool and Manchester Rly. (1830), **16, 17**.
- North Union Rly. locos., 34, 61.
- North Wales N.G. Rly., 0-6-4 Fairlie engines, 237.
- North Western Rly., "Little," Fairbairn's tank loco., 90, **91**.
- North Western State Rly. of India, 181, 183; Neilson's double engines, 314; C. Sandiford's compound engines, 327.
- Nova Scotia, locos. for, 139, 140.
- "*Novelty*" loco., 14, **15**.
- "*Oceanic*" compound engine, L. & N.W.R., 246.
- Oil fuel, 311.
- Oudh and Rohilkund Rly. locos., **181, 182**; Webb compounds, 327.
- Outside cylinder engines, 79.
- Overseas Military Rlys., 2-8-0 engines, 348, **349**.
- Owen's Patent Wheel and Axle Co., tires, 163.
- Oxford, Worcester and Wolverhampton Rly., E. B. Wilson's goods engines, **100**; 132.
- "*Pacific*" compound engine, L. & N.W.R., 246.
- Pacific type tender engines, L. & N.E.R., 335, **336**; **362, 363**.
- Paget, Sir Cecil, M.R. 2-6-2 engine, 343, **345**.
- Pambour, 65, 66.
- Panama Rly., Sellers locos. for, 319.
- Paris and Versailles Rly., Stephenson's engine, 31, **40**.
- Paris Exhibition (1867), 145.
- Paris Exhibition (1878), 202, 243.
- Paris, Lyons and Mediterranean Rly., 57; ditto, trials of Crampton locos., 73.

- Paris-Orleans Rly., 57, 58.
 Park, J. C., N.I.R. 0-6-0 tank loco., **282**.
 Parker, T., M.S. & L.R. 2-4-0 express engines, 267, **268**; ditto 2-4-2 tank engines, 277.
 Pasley, Genl., 62.
 Passenger tank engines, 150, 199, 305, 340.
 "Patentee" engine, L. & M.R. (1833), 22, **23**.
 Paton, W. (E. & G. Rly.), **59**.
 Peacock, R., M.S. & L.R. engines, **101**; experiments, M.S. & L.R., 114, 124.
 Pearson, J., Bristol and Exeter Rly. tank engines, **106, 107, 108, 109**; bogies, 119; B. & E.R. tanks speeds, 129; B. & E.R. water tubes, 175.
 Pendred, V., feed-water, 353.
 Penistone accident, M.S. & L.R., 215, 286.
 Pennsylvania Railroad, bogie, 219.
 Pen-y-darran loco., Trevithick's (1803), 6.
 Perdonnet "Chemins de Fer," 128.
 Performances of Webb's three-cylinder compounds, 250.
 Perkins, Jacob, 88.
 Phipps, G. H., 161; drawing of "Planet" engine, 19, **20**.
 "Phoenix" superheater, 352.
 Pickersgill, W., C. Rly. 4-6-2 tank loco., 364, **371**.
 "Pioneer" loco., Rothwell & Hick's (1832), 21, **22**.
 Pistons, Ramsbottom, 112.
 Piston valves, first engines to have (1832), 21; 287, 311, **352, 354, 365**.
 "Planet" loco. (1830), L. & M. Rly., 19, **20**; ditto type, model of, 124.
 Plate springs, 110.
 "Plews" loco., York, Newcastle and Berwick Rly., **78**.
 Pollitt, H., G.C.R. 4-2-2 express engines, 295, **297**.
 Polonceau blast-pipe, 285.
 Port Talbot Rly., 0-8-2 tank locos., **309**.
 "Precedent" class, L. & N.W.R., **192, 193, 266**; speed records, 230, 231, 236.
 "Precursor" class, L. & N.W.R., **192, 193**.
 "Prince of Wales" class, L. & N.W.R., 331.
 "Problem" class, L. & N.W.R., **144**.
 "Progress" loco., Neath and Brecon Rly., 315.
 Puerto Cabello and Valencia Rly., Lange and Livesey's rack loco., 320.
 Pullman cars, Midland Rly., 191.
 Pulverised fuel experiments, G.C.R., 364.
 Pumps, feed, 166.
 Purdue University, Dr. Goss's experiments on blast-pipes, 7.
 "Queen Empress," L. & N.W.R. loco., 290.
 "Queen" loco., G.W.R., **186**.
 Queensland Rlys., Kitson's loco. for, **183**.
 Queen Victoria's special train, Berwick-Newcastle, 130.
 Race to Edinburgh (1888), 312.
 Rack locomotives, Transandin Rly., **316, 317**.
 Rack rail locos., 320, **321**.
 Radial and other axle-boxes, 153, 154, 160, **225, 226**.
 Radial axle, W. Bridges Adams's, **161**.
 Radial valve gears, 39.
 Rainhill trials, Liverpool and Manchester Rly., 12.
 Rajputana-Malwa Rly. 4-4-0 engine, 239, **240, 242**.
 Ramsbottom, John, 91; piston, 112; D.X. engines, L. & N.W.R., **122**; uses link motion, 127; "Lady of the Lake" class, **144**; Bessemer tires, 163; lubricator and reversing gear, 166; L. & N.W.R. 2-4-0 engines, **169**; water pick-up apparatus, 369.
 Raven, Sir Vincent, N.E.R. three-cylinder Atlantic type engine, **336, 337**; N.E.R. three-cylinder tank engines, **339**; N.E.R. 4-6-0 goods engines, 346, **347**; N.E.R. Pacific type engines, 356, **363**; N.E.R. Uniflow Atlantic type engine, 357; N.E.R. self-trimming tenders, 371.
 Rear driver locos., **55 et seq.**
 Redtenbacher, Prof., 58.
 Regulators, 37; J. V. Gooch's, 53; Crampton's, 72; L. & N.W.R., 97; Hawthorn's, 111.
 Reid, W. P., N.B.R. 4-4-2 engines, 330, **331**.
 Rendell, A. W. (E.I. Rly.), 142.
 Rennie, G. & J., locos., 35, 47; London and Croydon Rly. engine, 41, **42**.
 Repairs, cost of, 111.
 Resistances, train, 228.
 Reuleaux, Prof., gauge glasses, 112.
 Reversing gear, 366; R. J. Billinton's, 311; J. Stirling's steam, 196; steam, 270; screw, 123, 166, 175; Webb's, 246.
 Reynolds, Edward, on stays, 175.
 Rhenish Rly., 156.
 Riches, T. H., Taff Vale Rly. 4-4-2 tank locos., **279**; ditto and S. B. Haslam, Institution of Mechanical Engineers' paper (1906), 350.
 "Richmond" loco., Great North of England Rly., 50.
 Richmond, Potomac, and Fredricksburg Railroad, "Pioneer" loco. drawing, **22**.
 Riekie, John, three-cylinder compound engines, 327.
 Rimutaka Incline, Fell locos. for, 319, **320**.
 Rivets for frames, etc., 125.
 Robertson, P., 115.
 Robinson, John, 209.
 Robinson, J. F., blast-pipes, 284.
 Robinson, J. G., compound "Atlantic" type engines, G.C.R., **323, 324**; "Director" class 4-4-0 engines, G.C.R., 329, **330**; G.C.R. 4-6-0 engines, 332, **333**; "Atlantic" engine, G.C.R. three-cylinder, 336; G.C.R. three-cylinder tank engine, **338**; G.C.R. 4-6-2 tank engine, **341**; G.C.R. 4-6-0 goods engines, 346; 2-8-0 goods engines, G.C.R. and War Office, 347, **349**; 0-8-0 goods engines, G.C.R., 347, **348**; piston valve, 354; 4-6-0 engines, G.C.R., 355; 2-6-4 tank engine, G.C.R., 363; pulverised fuel experiments, 364.
 "Rocket" loco., Liverpool and Manchester Rly. (1829), **11, 12**; S. & D. Rly., 10.
 Rogers, Thomas, coupling-rods, 287.
 "Rokeby" loco., S. & D. Rly., **57**.
 Roscoe lubricators, 166.
 Ross "pop" safety valves, 364.
 Ross Winan's blast-pipe, 285.
 Rothwell, Hick and, Rothwell's loco. "Pioneer" (1832), 21, **22**; loco., 35, **37**; goods engine, G.W.R. (b.g.), **47**; B. & E. Rly. tank locos., 106, **107**; blast-pipe, 353.
 Roy, Edmund, radial axles, 154, 160.
 "Royal George" loco., Stockton and Darlington Rly. (1827), **5**.
 Russia, loco. for, Hackworth's, 31.
 Sacré, Charles, 129; cabs, 177; M.S. & L. Rly. 4-4-0 engine, 214, **215**; M.S. & L. Rly. 0-6-0 goods engine, 222, **223**; 2-2-2 express engines, M.S. & L. Rly., **263**.
 Safety valve, Naylor's, **176**; Ross's "pop," 364.
 St. Helen's Rly., "White Raven" loco., **153, 225**.
 St. Neots, accident, G.N.R., 294.
 St. Rollox Works, 117, 171, 271.
 "Samson" goods engine, L. & M. Rly. (1831), **20, 21**.

- Samuel, James, motor coach, 84; patent for compound locos., 88.
- Sand-boxes, **112**, 177; ditto, N.B.R., 214.
- Sandiford, Charles, N.W. Rly. of India compounds, 327.
- Sanding apparatus, 39, 287; ditto, steam, 189, 266.
- Sandwich frames, 100, 113; G.W.R., 47.
- San Paulo Rly., Garratt loco., **318**.
- "*Sanspareil*" loco., T. Hackworth's (first), 13, **14**; (second), 77, **78**.
- Saratoga and Schenectady R.R., Stephenson's loco., 25.
- Schebesta, gauge glasses, 112.
- "*Schenectady*" loco. tests, 194.
- Schichau, 253.
- Schmidt, W., superheater, 352.
- Schneider & Co. (Creusot), 145.
- Scinde, Punjau and Delhi Rly. locos., 181.
- Scotch racing train (1888), 265; (1895), 251.
- Scotland, first locos. built in (1831), 11.
- Scottish Central Rly., 127, 206; goods engines, 82; steel fire-boxes, 166.
- Scottish North Eastern Rly., Yarrow's fire-box, 134.
- Seguin, Marc, locos. ordered by, 10.
- Sellers locos. for Panama R.R., 319.
- Semmering Incline, locos. for the, 137, 314.
- Serve boiler tubes, 310.
- Shap Incline, train working, 194.
- Sharp, Stewart & Co. (formerly Sharp, Roberts & Co. and Sharp Bros.), 47, 50, 56, 61, 63, 78, 97, 99, 123, 124, 129, 170, 171, 209, 300; Liverpool and Manchester Rly. and Dublin and Kingstown Rly. locos., **28**, 29; loco. by Sharp, Roberts & Co., 35, **38**; tank engines for the L. & N.W.R., **91**; "*Bloomer*" class engines, L. & N.W.R., **94**; Sharp Bros. goods engine, M.S. & L.R., **81**; tank locos. for Manchester and Birmingham Rly., 83; tank engine, Monmouthshire Rly., **103**, 104; Sharp's engines, Midland Rly., **93**, 94; mixed traffic engine, **100**; goods engine, M.S. & L. Rly., **101**; South Staffs. Rly. tank engine, **103**, 104; Sharp Bros. tank loco., Shrewsbury and Chester Rly., 105; Sharp's arrangement of inside cylinders, 110; expansion brackets, 110; engines, G.S. & W. Rly., 111; locos. for Jamaica and Demerara, 140; 2-4-0 engine for L.C. & D. Rly., 147; locos. for Furness Rly., 157; G. & S.W. Rly. locos., 157; goods locos. for Egypt and L.C. & D. Rly., 157, **158**; Taff Vale Rly. locos., 159; injectors, 166; Brecon and Merthyr Rly., tank loco., **174**; reversing gear, 175; G.I.P. Rly. locos., **181**; Oudh and Rohilkund Rly. locos., **181**, 182; Mauritius Rly. tank loco., **182**, 193; L. & S.W. Rly. 4-4-0 engines, **215**; L.T. & S. Rly. tank engines, 218, **219**; Bottomley axle-box, **226**; 0-8-0 tender engines, Swedish and Norwegian Rly., **281**; Barry Rly., 281, **282**; L.T. & S. Rly. tanks, 305; M. & S.W.J. Rly. tank engines, 305; Highland Rly. 4-6-0 engines, **307**; 0-8-2 tank engines for Barry Rly., **309**; Cornwall Minerals Rly. loco., **313**; New Zealand Rlys. engines, 321; tenders, 367; Shrewsbury and Chester Rly. tank loco., 105.
- Sheffield and Rotherham Rly., 63.
- Shepherd and Todd, 42; Hull and Selby Rly. locos., **49**, **76**.
- "Short Stroke" locos., 31.
- Shrewsbury and Birmingham Rly., bar-framed engine, 76.
- Shrewsbury and Chester Rly., Vulcan Foundry loco., **86**; Vulcan Foundry 0-4-2 engine, **99**, 100; Bury's 0-4-0 tank loco., **105**.
- Shrewsbury and Hereford Rly., Vulcan Foundry loco., **96**, 97; locos., 100.
- Shunting (small) engines, 224; engines with Kitson's valve gear, **284**.
- Shutt End Rly. engine "*Agenorina*," 11.
- Side doors to foot-plates, 287.
- Siemens, Sir Wm., 284.
- Sinclair, Robert, 83, 88, 89, 111, 180; steel, 165; 2-4-0 goods engines, Eastern Counties Rly., **118**; engine for Belgium, **137**, 138; G.E.R. express engine, **144**, 145; Great Eastern Rly. tank loco., **154**; slotted frames, 160; reversing gear, 166; Caledonian Rly., 225.
- Single cylinder locos., 125, **126**.
- Single driving wheel tank locos., 89.
- Single driver express engines, inside cylinders, 113; 2-2-2 and 4-2-2 locos., 294.
- Single Fairlie tank engine, **224**.
- Single versus coupled express engines, 187.
- Sirhowy Rly., 174.
- "*Sir Sam Fay*" class engines, G.C.R., 332, **333**.
- Six-coupled tender engines, 173; ditto tank engines, 174, 175, 201, 220, 275, 281; ditto goods engines, 157.
- Slaughter's patent hercontrolling arrangement, 161, 162.
- Sledge brakes, 137; ditto, G.W.R., 70.
- Slide valves, balanced, 175; F. W. Webb's circular, **226**.
- Sligo, Leitrim and Northern Co.'s Rly. loco., **237**.
- "Small Bloomer" engines, L. & N.W. Rly., **94**, 95.
- Smellic, Hugh, G. & S.W.R. 2-4-0 engine, **212**; G. & S.W.R. 4-4-0 engines, **272**; smoke-box, 310.
- Smith, W. H., & Son's special train, 130.
- Smith, W. M., piston valves, 287; N.E.R. three-cylinder compound engine, 289, **290**, 293; M.R. compounds, 322, **323**; G.C.R. compounds, **323**, 324; N.E.R. four-cylinder compound 4-4-2 engines, 326, **327**.
- Smoke, Act prohibiting emission of, 131.
- Smoke-boxes, 310; ditto doors, 111.
- Smoke consuming, 131.
- Smyrna-Aidin Rly., Stephenson's engine, 138.
- Snowdon Mountain Rly., rack locos., 320, **321**.
- Societe Alsacienne, G.W.R. De Glehn compounds, **325**.
- Somerset and Dorset Joint Rly., Sir Henry Fowler's 2-8-0 engines, 348, **350**.
- South African Rlys. Mallet articulated loco., **317**.
- South Australia, locos. for, 140; ditto 0-6-4 tank loco., 237.
- South Carolina R.R., articulated loco., 313.
- South Devon Rly., 70.
- South Eastern and Brighton Rlys., Bodmer's engine, **61**, 62.
- South Eastern and Chatham Rly., rail motors, 350; Maunsell's top-feed system, 353; reconstructed 4-4-0 engines, 355; Maunsell's three-cylinder 2-6-0 engines, 357; Maunsell's 2-6-4 tank engine, 363, **368**; pony trucks, 364.
- South Eastern Rly., 151; Crampton locos., 71, 72; ditto tank locos., 86; Crampton express locos., **86**, 87; uniflow loco., 88; Cudworth's coupled engine, **98**; Cudworth's 2-4-0 engine, **117**; Cudworth's fire-box, **133**, 134; Cudworth's "Mail" engine, **147**; axles, 165; Cudworth's 0-4-4 tank engines, **172**; sand-box, 177; speed records, 229; speeds, 231; J. Stirling's 4-4-0 engines, **270**; J. Stirling's 0-4-4 tank engines, 277; Cudworth's tenders, 367.

- South German Rlys., 80, 240.
 South Indian Rly. tender engines, 239, 242; rack engines, 321.
 South Staffs. Rly., Sharp Stewart & Co. tank engine, 103, 104.
 South Yorks. Rly., Thwaites Bros.' loco. "*Albion*," 84, 85.
 Southern Mahratta Rly., 2-6-0 engines, 240.
 Southern Rly., R. E. L. Maunsell's 2-6-4 tank loco., 363, 368.
 Spark arresters, 353.
 Special types of express engines, 73.
 Speeds and performances, 65, 66, 312.
 Speeds, G.W.R.-B.G., 129; L. & N.W.R., 130.
 Spencer, G., feed-water purifier, 352.
 Spring arrangement, Caillet's, 159.
 Springs, 38, 110; indiarubber, 96; G.W.R., 113; spiral, 287; Timmis, 226, 353.
 Spring gear, 208; Cudworth's, 98; B. & E. Rly., 106, 108; McConnell's, 80.
 "Standard" passenger engines, inside cylinders, 76.
 Stanhope and Tyne Rly., goods engines, 24, 25.
 Starting valve, Webb compounds, 246.
 Stays, 126; direct roof, 175.
 Steam jackets, 311.
 Steam motor coach locomotives, 84, 350.
 Steam pressures, 112.
 Steam tender locos., 160, 237.
 Steel axles and motion parts, 165.
 Steel Committee tests, 164, 165.
 Steel, John, superintends building of Wylam loco. (1805), 6.
 Steel, tires, 163, 164; use of, in boilers, etc., 206.
 Stephenson, J. F., 207, 208.
 Stephenson and Howe's patent engine, 75.
 Stephenson, George, 131; his locomotives on the S. & D. Rly., 1.
 Stephenson, Robert, 70; on L. & M. Rly. locos., 31; on centre of gravity, 78; link motion, 127.
 Stephenson, Robert, & Co., 82, 84, 118, 124, 158, 173, 181, 203, 313; three-cylinder engine, 130; locomotives for the S. & D.R., 1, 2, 3, 4; loco. "*America*" for Delaware & Hudson Canal Co., 10, 11; loco. "*Lancashire Witch*," B. & L. Rly., 9; locos. for France, 10; engine "*Rocket*" for the L. & M. Rly. (1829), 11, 12; "*Northumbrian*" engine, L. & M. Rly. (1830), 16, 17; loco. "*Invicta*," C. & W. Rly. (1830), 17; engine "*Planet*" (1830), L. & M. Rly., 19, 20; 0-4-0 goods engine (1831), 21; six-wheeled engine "*Patentee*" (1833), 22; Patent engine, 23; exhaust pipe, 24; bogie locos., 24; 2-4-0 engines, 52; 0-4-2 goods engines and 0-6-0 ditto, 24, 25; Saratoga and Schenectady R.R. loco., 25; "*Planet*" type locos., 31; 2-2-2 type engine, 35; engine for N. Midland Rly., 35; engine, Paris and Versailles Rly., 40; "*Star*" class, G.W.R., 44, 45; long boiler engines, 53; long boiler goods engine, 54; engine, Yarmouth and Norwich Rly., 54; third type of long boiler passenger engine, 55; engine, York, Newcastle and Berwick Rly., 56; long boiler goods engine, 58; engine, L. & N.W.R., 74, 75; three-cylinder engine, 75; engine with mixed framing, 77; S.E.R. Crampton locos., 86; Crampton express locos., S.E.R., 86, 87; Crampton express engines, L.C. & D.R., 87, 88; locos., Midland Rly., 93, 94; engine, Chester and Birkenhead Rly., 98; engines for Egypt, 99, 139; Midland Rly. engines, 101; long boiler goods engines, 102; goods engines, N.E.R., 104; arrangement of inside cylinders, 109, 110; G.W.R. b.g. 4-4-0 engines, 115; bogies, 119, 162; tank engine, North London Rly., 119, 120; locos. for Giovi incline, 137; engine, Gt. Luxembourg Rly., 137, 138; engine, Smyrna-Aidin Rly., 138; locos. for Egypt, 139; locos. for N. South Wales, Victoria and S. Australia, 139, 140; bogie engines for S. & D. Rly., 148, 149; engines for N.E.R., 150; reversing gear, 175; water tube boiler, 176; eab, 177; L. & S.W.R. 4-4-0 engines, 216, 217; M.R. goods engines, 221; long boiler engine, Eastern Counties Rly. and Crampton S.E.R., 229; locos. for Natal and New South Wales, 238; Imperial Japanese Rlys., 238; G.N. of S.R. engines, 272; L. & S.W.R. tank locos., 278; four-cylinder engine, 300; compounds for the Antofagasta Rly., 321; N.B.R. 4-4-2 engines, 330, 331; 2-8-0 engines for Govt., 348; Somerset and Dorset Joint Rly. 2-8-0 engines, 348, 350; L.T. & S.R. engines, 353; L. & N.E.R. tank engines, 363; four-wheeled tender, 366.
 Stewart, —, compound engines, 89.
 Stirling, James, 0-4-2 engines, G. & S.W.R., 172; 4-4-0 express engines, G. & S.W.R., 195, 196; S.E.R. 4-4-0 engines, 270; engine bogie and steam reversing gear, 219, 270, 271; S.E.R. 0-4-4 tank engines, 277; tenders, 367.
 Stirling, Messrs., Dundee, engines for the Arbroath and Forfar Rly., 40, 42.
 Stirling, Patrick, 40, 41, 100, 118, 166; Crampton loco., G. & S.W.R., 87, 88; G. & S.W.R. express engine, 114, 115; 0-4-2 engine, G. & S.W.R., 118, 119; goods engine, G. & S.W.R., 125; goods engine, G. & S.W.R., 157; G.N.R. express engine and ditto rebuilt, 168; 2-4-0 engines, G.N.R., 168, 169; 0-4-2 engines, G.N.R., 171, 172; G.N.R. goods engines, 203, 204; "singles" speeds, 231; 2-2-2 express engines, G.N.R., 263, 264; G.N.R. 8ft. single express engines, 185, 294; G.N.R. 2-4-0 engines, 296; G.N.R. tenders, 367, 369.
 Stirling, Robert, Kitson-Meyer loco., Anglo-Chilian Nitrate and Rly. Co., 316.
 Stockton & Darlington Rly., First locos. of, 1 *et seq.*; Wilson's 4-cyl. loco. (1825), 3; loco. "*Experiment*" (1827), 4; "*Royal George*" loco. (1827), 5; "*Rocket*" loco., 10; engine "*Victory*" (1829), 10; Hackworth's vertical cylinder locos., 26; loco. "*Swift*," 29, 30; "*Arrow*" loco., 31; "*Sunbeam*" loco., 31; Hackworth's engines with inclined cylinders, 33; "*Raby Castle*" loco., 36, 39; engine "*Queen*," 40, 41; engine "*Dart*," 40, 41; "*Derwent*" loco., 48; "*No. 33*" loco., 49; loco. "*Meteor*," 50, 57; long boiler passenger engines, "*Woodlands*" and "*Rokeby*," 57; goods engines with outside cylinders, 58, 59; fuel consumption, 65; long boiler goods engines with outside cylinders, 58, 59; fuel consumption, 65; long boiler goods engine, 102; coal burning, 131; Stephenson's bogie engines, 138, 149; Bouch's 0-6-0 engines, 173; blast-pipes, 176; 2-4-0 engine, 195; Bouch's 4-4-0 engines, 197; long boiler goods engines, 204; Bouch's steam retarder, 209.
 Stockton and Hartlepool Rly., 48.
 Stothert and Slaughter, 47, 149; Monmouthshire Rly. bogie engine, 119; N.L.R. tank engines, 105; Monmouthshire Rly. tank locos., 105, 107; engines for E. Indian Rly., 141.
 "*Stourbridge Lion*" loco. (1829), 10, 11.
 Stratford and Midland Junction Rly. 2-4-0 engine, 296.

- Stratford Works, 90.
- Strong-, Radial axles, 154.
- Stroudley, William, 124; feed pumps, 166; L.B. & S.C.R. single express engine, **187**; 2-4-0 express loco., L.B. & S.C.R., 191, **192**; 0-4-2 tank locos., L.B. & S.C.R., **199**, 275; 0-6-0 tank engines, L.B. & S.C.R., 201, **202**; L.B. & S.C.R. goods locos., **203**; L.B. & S.C.R. 0-4-2 tender engines, 217; 0-4-2 express engines, L.B. & S.C.R., 273, **274**; L.B. & S.C.R. goods engines, 279; ashpan dampers, 285; L.B. & S.C.R. tenders, 367-8.
- Stubbs, —, 0-8-0 tender loco., 160.
- Stumpf Uniflow engine, N.E.R., 346, **347**, 354.
- Sturrock, Archibald, 88; on high pressures, 93, 94; express engine, G.N.R., **97**; crank axle, 112; bogie, 119; express engine, G.N.R., **146**, 147; tank locos., G.N.R., **155**; steam tender loco., **160**; G.N.R. express engine, **168**; speeds, 232.
- Sun Foundry, 82.
- Superheating, 311, 352.
- Swedish and Norwegian Rly., Sharp, Stewart's 0-8-0 engine, **281**.
- Swindon, Marlborough and Andover Rly., single Fairlie tank locos., **224**.
- Swindon Works, 199, 205; tires, 164.
- Swiss Loco. Works: Snowdon Mountain Rly. rack locos., 320, **321**.
- Sydney and Goulburn Rly., locos. for, **139**, 140.
- TABLE I. Single express engines (1860-65), 145.
 „ II. Steel tires, 164.
 „ III. Locomotive performances at the Newark brake trials (1875), 235.
 „ IV. L. & N.W. Up Scotch Expresses (1877-78), 236.
 „ V. L. & N.W. Down Expresses (1876-78), 236.
 „ VI. Midland Rly. Coal Consumption, 236.
 „ VII. Engines for Ireland and Overseas, 242.
 „ VIII. Metre Gauge Engines, Indian Rlys., 242.
 „ IX. Express Engines with Single Driving Wheels, 288.
 „ X. Express and Passenger Engines with 4-coupled Wheels, 288.
 „ XI. Express Locos., Period 1890 to 1899, Engines with Four High-pressure Cylinders, 302.
 „ XII. Compound Engines (1901-7), 328.
 „ XIII. 4-4-0 Engines (1900-14), 334.
 „ XIV. 4-4-2 Engines (1903-11), 334.
 „ XV. 4-6-0 Engines (1902-14), 334.
 „ XVI. Tank Engines (1901-14), 342.
 „ XVII. British Express Engines (1915-25), 359.
 „ XVIII. Mixed Traffic, Goods and Mineral Tender Engines (1915-25), 359.
 „ XIX. British Tank Engines (1914-25), 360.
- Taff Vale Rly., 136, 174; banking locos., 159; tires, 163; axles, 165; T. H. Riches 4-4-2 tank loco., **279**; rail motors, 350.
- Tail rods, 311.
- Talybont Incline (B. & M. Rly.), 174.
- Tank engines, 43, 112, 363; passenger, 83; with coupled wheels, 104; broad gauge, 105; with leading bogies, 119; 6-coupled passenger, 122; Neilson's single cylinder, 125, **126**; for steep gradients, 159; 8-wheeled, 277; G.N.R. 2-6-0 type, 309.
- Tasmanian Rly., Garratt locos., 318.
- Tay Bridge disaster, N.B.R., 195.
- Tayleur, C., & Co., locos., **35**, 55, 56, 62, 70; locos. for Camden and Woodbury R.R., 25, **26**; bogie locos., 24; locos. for L. & M. Rly., 31; engines for the Leicester and Swannington Rly., 40; engines for the G.W.R., 43; tank engines, **83**.
- Tenders, Locomotive, 112, 366; cylindrical "boiler" tank, for a German Rly., 112; bogie, J. Manson's, 272-3.
- "Tennants," The, N.E.R. 2-4-0 express engines, 266, **267**.
- Ten-wheeled tank engines, 4-4-2 type, 278.
- "Terrier" tank locos., L.B. & S.C.R., 201, **202**.
- "Teutonic" class compound loco., **246**.
- Three-cylinder engine, 75; ditto tank engines, 337; ditto compound engines, 291; ditto, W. M. Smith's system, 293; ditto engine, Beyer, Peacock & Co., 293; ditto non-compound express engines, 336.
- Thwaites Bros. loco., **84**, 85.
- "Times" special train, Euston-Glasgow, 130.
- Timmis spiral springs, 226, 353.
- Tires, 162; Marshall's steel, Krupps and Beattie's, **127**; spring, 153; fastening, Carlton and Stroudley's, 286.
- Todd, Charles, starts Sun Foundry, 82.
- Todd, F. J., Uniflow stationary engine, 88.
- Tomlinson, Joseph, 48, 63, 158, 174; remarks on performance of "Locomotion," 3; on Hackworth's design, 31, 32; coal burning trials, 136; banking locos., 159; tires, 163; axles, 165; frames, 285.
- Tomlinson, W. W., remarks on Wilson's loco. for S. & D. Rly., 3.
- Tosh, G. (Maryport and Carlisle Rly.), steel fire-boxes, 166.
- Train resistances, 228.
- Transandine Rly., Kitson-Meyer loco., **316**, 317.
- Tredgold's book on "The Steam Engine," 31, 83, 84, 129.
- Trevithick, Francis, 70; engine "Cornwall," 73, **74**; express engines, 97; tank engine, L. & N.W.R., **121**.
- Trevithick, F., Cornwall Minerals Rly. locos., **313**.
- Trevithick, F. H., Egyptian State Rlys. feed-water experiments, 352.
- Trevithick, Richard, blast-pipe of his locomotive (1804), 6.
- Triple-expansion loco., F. W. Webb, 293.
- "Triplex" engine, L. & N.W.R., 293.
- Tritton, Sir Seymour, on Indian locos., 241.
- Trucks, Bissell, 127.
- Tubes, 132, 207.
- Tube expander, Dudgeon's, 175.
- Tudela and Bilbao Rly. (Spain), 155; Beyer, Peacock's engine, **184**.
- Tulk and Ley, 72; engines for Namur and Liège Rly., 70, **71**.
- Twin locos., back to back, **313**; tank locos., Giovi Incline, Italy, **137**.
- "Twin Sisters" loco., Liverpool and M. Rly., 131.
- Two-cylinder high-pressure engines, 294; ditto compound engines, 253, 289, 306.
- Tyler, Capt. H. W., Paper before the Inst. of Civil Engineers, 319.
- Uganda, Mallet loco., 317.
- Ulster Rly. loco., 178; 0-4-2 loco. for, **179**.
- Uniflow engines, 88; Atlantic type loco., N.E.R., 357.
- United States metallic packing, 287.

- Urie, R. W., L. & S.W.R. 4-6-0 goods engines, 346; L. & S.W.R. 4-6-0 engines, 355, **356**; L. & S.W.R. 4-6-2 tank engine, 363, **368**; L. & S.W.R. 4-8-0 shunting engines, 364, **370**; L. & S.W.R. bogie tenders, 371.
- Urquhart, Thomas, oil-fuel burning, 311.
- Vale of Neath Rly., tank locos., 106, 159, 161.
- Valves and valve gears, 39, 110, 112, 127, 226, 287, 311.
- Valve gear, Midland Rly., **109**, 110; Hawthorn's, **110**; Walschaert's, 224; Joy's, 221, 226; differential, for compounds, 258; Bryce-Douglas's, 271; J. H. Kitson's, 284; of "Teutonic" class engines, 247; R. M. Deeley's, 329.
- Vanderbilt boilers, 351.
- Verderber fire-box, 310.
- Verpilleux, M., steam tender loco., 160.
- Vickers, axles, 165.
- Victoria, Locos. for, 140.
- Victoria, Queen, special from Berwick to Newcastle, 130.
- "Victory" loco., S. & D. Rly., 10.
- Vignoles & Ericsson, patent locos. for steep grades, 319.
- Vivian & Sons, Garratt loco., 318.
- Vulcan Foundry, 54, 77, 83, 95, 141, 153, 180; Bristol and Birmingham Rly. loco., **54**; loco., Shrewsbury and Chester Rly., **86**; Dublin and Wicklow Rly. locos., 90; Shrewsbury and Hereford Rly. locos., **96**, 97; Shrewsbury and Chester Rly. 0-4-2 engine, **99**, 100; Vale of Neath Rly. tank locos., 106; tenders, 112; loco. for G.I.P. Rly., **140**, 183; loco. for Imperial Japanese Rlys., 237; Eastern Bengal and Indian State Rlys. locos., 239, **240**; I.S.R. "O" class engines, 240, **241**, 242; T. H. Riches, T.V. Rly. 4-4-2 tank loco., **279**; Fairlie locos. for Mexican and Burma Rlys., 315, 316; Chilean Govt. Rlys. locos., 321; rack engines, Central S. African Rlys., 321; G.N.R. four-cylinder compound 4-4-2 engines, 325, **326**; tenders, 367.
- Wagner, Herr, feed-water heater, 352.
- Wakefield, John, loco. for G.S. & W. Rly., **177**; 0-4-2 locos. for G.S. & W. Rly., 178.
- Waldegg, Heusinger von, 240; blast-pipe in Germany, 7.
- Walschaerts valve gear, 224, 289, 311.
- Wardale, J. D., bogie design, 162.
- War Office, 2-8-0 goods engines, 347, **349**.
- "Waterford" 4-4-0 engine, G.W.R., **300**.
- Waterford and Kilkenny Rly., Tayleur's tank engines, **83**.
- Water bottom ashpan, 227.
- Water pick-up apparatus, 287, 369.
- Water tubes, fire-box, 131, 293, 299, 310.
- Watson, E. A., G.S. & W.R. four-cylinder 4-6-0 engines, 355, **360**; G.S. & W.R. 4-8-0 tank engines, 364, **372**.
- Webb, F. W., friction wheel coupling, 32; wind deflectors, 112; L. & N.W.R., 2-4-0 express locos., **192**, 193; L. & N.W.R. coal engines, **204**; adopts steel for boilers, 206; L. & N.W.R. 2-4-0 tank engines, 219, **220**; L. & N.W.R. 0-6-0 goods engine, 221, **222**; L. & N.W.R. small shunting engine, 224, **225**; radial axle-box, **225**; circular slide valves, **226**; fire-hole, 227; water bottom ashpan, 227; first compound locos., **243**; "Compound" class engines and "Dreadnought" ditto, **243**, **244**, **245**; reversing gear, 246; starting valve, "Teutonic" class compounds, **246**; continuous expansion engine, 246; three-cylinder system, advantages of, 247; three-cylinder compound system, defects of, 248; L. & N.W.R. compound tank engines, **252**, **253**; boilers, 284; steel castings, 286; L. & N.W.R. "Greater Britain" class compounds, 290, **291**; L. & N.W.R. 0-8-0 mineral engines, 291; four-cylinder compound express engines, 292, **293**; triple expansion engine, 293; L. & N.W.R. 2-4-0 engines, 295; L. & N.W.R. four-cylinder non-compound engine, 301; L. & N.W.R. 0-6-2 passenger tank locos., 306; L. & N.W.R. 0-8-0 mineral engine, 308; fire-box design, 310; double chimney, 310; crank axles, 310; L. & N.W.R. bogie truck, 311; compounds, Antofagasta Rly., 321; four-cylinder 0-8-0 compound engines, **324**; four-cylinder compound 4-6-0 engines, 324; Oudh and Rohilkund State Rly. compounds, 327; three-cylinder simple engine, 336.
- Wedge motion, 63.
- Weight distribution, 78.
- Welsh coal burning on locos., 136.
- West Midland Rly., Beyer, Peacock's tender engine, **148**; Beyer, Peacock's tank loco., **151**.
- West Point Foundry, articulated loco., 313.
- Whale, George, scraps compounds, 252; modifications to four-cylinder compounds, 324; L. & N.W.R. 4-4-0 engines, 328, 330; L. & N.W.R. 4-6-0 goods engines, 346.
- Wheatley, Thomas, 208; N.B.R. 0-6-0 tank locos., 175; N.B.R. 4-4-0 express engine, 195, **196**.
- Wheel arrangements, B. & E. Rly. tank locos., **109**.
- Wheels, axles and springs, 63, 208, 286.
- Whinfield, John, builder of Wylam Colliery loco. (1805), 6.
- Whishaw, on speed records, 66, 67.
- Whitby-Malton section, N.E. Rly., engines for the, **150**.
- "White Horse of Kent" loco., S.E.R., 55.
- Whitelegg, Thomas, L.T. & S.R. 4-4-2 tank locos., 305; variable blast-pipe, 353.
- Whitelegg, R. H., G. & S.W. Rly. four-cylinder 4-4-0 engine, 301, 355, **356**; G. & S.W. Rly. 4-6-4 tank engines, 364, **372**.
- "White Raven" loco., St. Helen's Rly., **153**, **161**, 225.
- "Wilberforce" class locos., Stockton and Darlington Rly., **26**.
- Willans, F., Wrexham, Mold and Connah's Quay Rly. 2-6-0 tank loco., 309.
- Williams-Howe link motion, 63.
- Wilson, Edward, 132.
- Wilson, E. B., & Co., 56, 82, 97, 101, 123, 129; Crampton loco. for E.I. Rly., 72; "Jenny Lind" type locos., 76, **77**; 2-4-0 engine, **80**, 81; loco. "Lablache," 84; Crampton tank loco., **86**; tank engines, 91; L. & N.W.R. express locos., **95**; goods engine, O.W. & W. Rly., **100**; double boiler tank engine, **104**, 105; engines for S.E.R., 117; locos. for G.I.P. Rly., **141**.
- Wilson, James E., patent loco., **181**, 182.
- Wilson, Robert, four-cylinder loco., S. & D. Rly. (1825), 3.
- Windsor and Annapolis Rly. locos., 183.
- Wirral Rly. 4-4-4 tank engines, **305**.
- Wohler, —, radial axle-box, 160; tests of axle steels, 165.
- Wolverhampton Works, 102, 199, 205.
- "Woodlands" loco., S. & D. Rly., **57**.

- Wood, Nicholas, remarks on blast-pipe, 7.
- Woods, Edward, 65, 128, 132, 139; observations on L. & M. Rly. locos., 31.
- Worcester Engine Co., Met. Rly. tank locos., 174.
- World Power Conference, 356.
- Worsdell, T. W., 206; two-cylinder compounds, G.E.R., 253, 254; N.E.R. 2-4-0 and 4-4-0 two-cylinder compounds, 254, 256; N.E.R. 4-2-2 compound express engine, 255; 0-6-0 compound goods engine, 257; 0-6-2 compound tank engine, N.E.R., 257, 258; G.E.R. 2-4-0 express engine, 266; G.E.R. 2-4-2 tank engines, 277; N.E.R. 2-4-2 tank engines, 277; fire-box girders, 284; steel castings, 286; tire fastening, 286; I section coupling-rods, 287; cabs, 287; compounds, Bengal-Nagpur and Indian Midland Rlys., 327.
- Worsdell, Wilson, converts N.E.R. compounds to simple, 260; N.E.R. two-cylinder compound engine, 289; N.E.R. three-cylinder compound express engine, 289, 290; rebuilt N.E.R. 4-2-2 express engines, 295, 296; N.E.R. 4-4-0 engines, 297, 298, 299; N.E.R. 4-6-0 express engines, 304; N.E.R. four-cylinder compound 4-4-2 engines, 326, 327; N.E.R. 4-4-0 engines, 329; N.E.R. 4-4-2 engines, 330, 332; three-cylinder tank engines, 338, 339; N.E.R. 4-6-0 tank engines, 340; N.E.R. 0-8-0 goods engines, 346.
- Worthington, E., 327; on compound engines, 243.
- Wrexham, Mold and Connah's Quay Rly., F. Willans's tank engine, 309.
- Wright, W. B., L. & Y. Rly. 0-4-4 tank engines, 218; 0-6-2 L. & Y. Rly. tank engines, 220.
- Wylam engines, later, 10.
- Wylam Colliery, Blackett's loco. (1804), 6 *et seq.*
- Wyoming Valley Rly., three-cylinder engines, 336.
- Yarmouth and Norwich Rly., Stephenson's engine, 54.
- Yarrow, —, fire-box, 134.
- York and North Midland Rly. locos., 43, 53, 56, 58; goods engines, 82.
- York, Newcastle & Berwick Rly., 130; Stephenson's engine, 56; trials, 67; three-cylinder loco., 75; "Sanspareil" loco., 77, 78; "Plews" loco., 78.
- Yorkshire Engine Co., 168; G.N.R. engines, 169; I.S.R. engines, 239; Fairlie loco. for Mexican Rly., 314.
- York, L. & N.E. Rly. Museum, 204.

